

FANTIBOZZETTIMENEGON



<u>1</u>	FANTIBOZZETTIMENEGON	p.4
	<i>accessori accessories</i>	
<u>2</u>	brique   vasi in marmo <i>marble vases</i>	p.8
<u>3</u>	contentus   vassoio in ottone <i>brass tray</i>	p.10
<u>4</u>	narciso   specchio <i>mirror</i>	p.12
<u>5</u>	nebra   vassoio in ceramica <i>ceramic tray</i>	p.14
<u>6</u>	slice   vasi in marmo <i>marble vases</i>	p.16
	<i>complementi complements</i>	
<u>7</u>	andromeda   libreria <i>bookcase</i>	p.22
<u>8</u>	cerbero   tavolo <i>table</i>	p.28
<u>9</u>	comodo   servo muto <i>valet stand</i>	p.36
<u>10</u>	dioniso   carrello per liquori <i>liquor trolley</i>	p.38
<u>11</u>	era   madia in marmo <i>marble madia</i>	p.44
<u>12</u>	kristalia   credenza in vetro <i>glass display</i>	p.50
<u>13</u>	narciso   consolle, vanity & comodino <i>console, vanity desk &amp; bedside table</i>	p.52
<u>14</u>	ofiuco   tavolini e panca <i>coffee tables and bench</i>	p.62
<u>15</u>	venere   consolle & madia <i>console &amp; sideboard</i>	p.72
<u>16</u>	vesta   cabina armadio <i>closet</i>	p.76
	<i>materiali materials</i>	p.87
	<i>schede tecniche technical sheets</i>	p.93

# 1

## FANTIBOZZETTIMENEGON

FANTIBOZZETTIMENEGON nasce nel 2019 dalla collaborazione tra gli interior designer Fabio Fanti Bozzetti e Martina Menegon, orientata alla costante ricerca di nuove interpretazioni architettoniche di spazi abitativi pubblici, privati e al disegno di complementi d'arredo.

Le atmosfere progettuali di FANTIBOZZETTIMENEGON mirano a conciliare elegantemente i molteplici valori dell'abitare. Ogni progetto possiede la propria voce distintiva in un equilibrio costante, unico, tailor-made, declinato alle differenti esigenze senza perdere essenza ed autenticità.

"In ogni progetto è fondamentale l'equilibrio. L'organico ed il tecnico, la semplicità e la ricchezza, la forma e l'uso"

Le conoscenze maturate negli anni, la costante ricerca e l'attenzione ai dettagli sono strumenti a servizio del cliente per plasmare i sogni in materia tangibile rendendo unico il percorso creativo.

Interni raffinati e contemporanei, luoghi da vivere e condividere, che spaziano dall'interior design di eleganti abitazioni Italiane fino alle più moderne ville unifamiliari all'estero ridefinendo una modernità libera che integra il passato ma in costante armonia con il presente.

Nel 2020 lo studio approfondisce e sviluppa la sua linea di complementi d'arredo, avvalendosi dell'esperienza legata alle molteplici necessità e culture dei clienti. Una collezione moderna ma dal gusto retrò in grado di comunicare il pensiero progettuale già al primo sguardo. Forme severe ma morbide, materiali preziosi ma composti, elementi che spaziano dal living alla camera da letto, passando dai piccoli accessori, fino ai complementi pensati per l'alta ristorazione.

Il nuovo showroom inaugurato nel 2021 a Milano in via dei Giardini è stato pensato come uno spazio condiviso con il cliente che può immergersi nell'essenza creativa alla base di ogni progetto.

Un'ambiente intimo e luminoso ricco di dettagli ricercati che rappresenta una vetrina per l'intera collezione d'arredo, risultato di lavorazioni interamente artigianali, realizzata dalle più esperte maestranze italiane e prodotta da For Living, una delle più vivaci realtà italiane nell'ambito dell'interior design contractor.

FANTIBOZZETTIMENEGON was founded in 2019 through the collaboration between interior designers Fabio Fanti Bozzetti and Martina Menegon, focused on the constant research for new architectural interpretations of public and private living spaces, as well as the design of furniture accessories.

The design atmospheres of FANTIBOZZETTIMENEGON aim to elegantly reconcile the multiple values of living. Each project possesses its own distinctive voice in a constant, unique, and tailored balance, which is adapted to different needs without losing essence and authenticity.

"In every project, balance is fundamental. The organic and the technical, simplicity and richness, shape and function."

The knowledge acquired over the years, constant research and attention to details are tools for serving clients to shape their dreams into tangible matter, making the creative process unique.

Refined and contemporary interiors, places to live in and share, ranging from the interior design of elegant Italian homes to the most modern single-family homes abroad, redefine a free modernity that integrates the past but is in constant harmony with the present.

In 2020, the studio deepened and developed its line of furniture accessories, drawing on the experience associated with the diverse needs and cultures of clients. The accessories collection is modern but with a retro taste, capable of communicating the design thinking at first glance. Severe but soft shapes, precious but composed materials, elements ranging from living room to bedroom, passing through small accessories, up to complements designed for high-end restaurants.

The new Milanese showroom, opened in 2021 in Via dei Giardini, was designed as a space shared with the client who can immerse themselves in the creative essence underlying each project. An intimate and bright environment rich in refined details that represents a showcase for the entire collection of furniture accessories, the result of entirely artisanal workmanship, created by the most experienced Italian craftsmen and produced by For Living, one of the most vibrant Italian realities in the field of interior design contracting.





*accessori accessories*

2

**brique** | vasi in marmo *marble vases*

3

**contentus** | vassoio in ottone *brass tray*

4

**narciso** | specchio *mirror*

5

**nebra** | vassoio in ceramica *ceramic tray*

6

**slice** | vasi in marmo *marble vases*



2

**brique** | vasi in marmo *marble vases*

Serie di vasi composti da dischi in ottone naturale e tozzetti di marmo rosso Levanto.

*Custom made by Casone per FANTIBOZZETTIMENEGON.*

*Series of vases composed of natural brass discs and pieces of red Levanto marble. Custom made by Casone for FANTIBOZZETTIMENEGON.*

Ø 40 x 12 cm

Ø 28 x 64 cm





### 3

**contentus** | vassoio in ottone *brass tray*

Vassoio in ottone naturale con particolare cubo accessorio in mosaico di marmo.

*Natural brass tray with special accessory cube in marble mosaic.*

60 x 17 x 4 cm



4

**narciso** | specchio *mirror*

Specchio a forma di biscotto, bisellato con  
magnificatore integrato.

*Biscuit-shaped mirror, bevelled with integrated feeder.*

50 x 3 x 100 cm

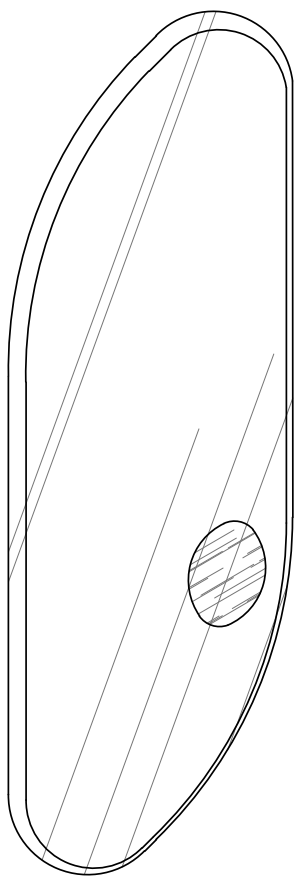

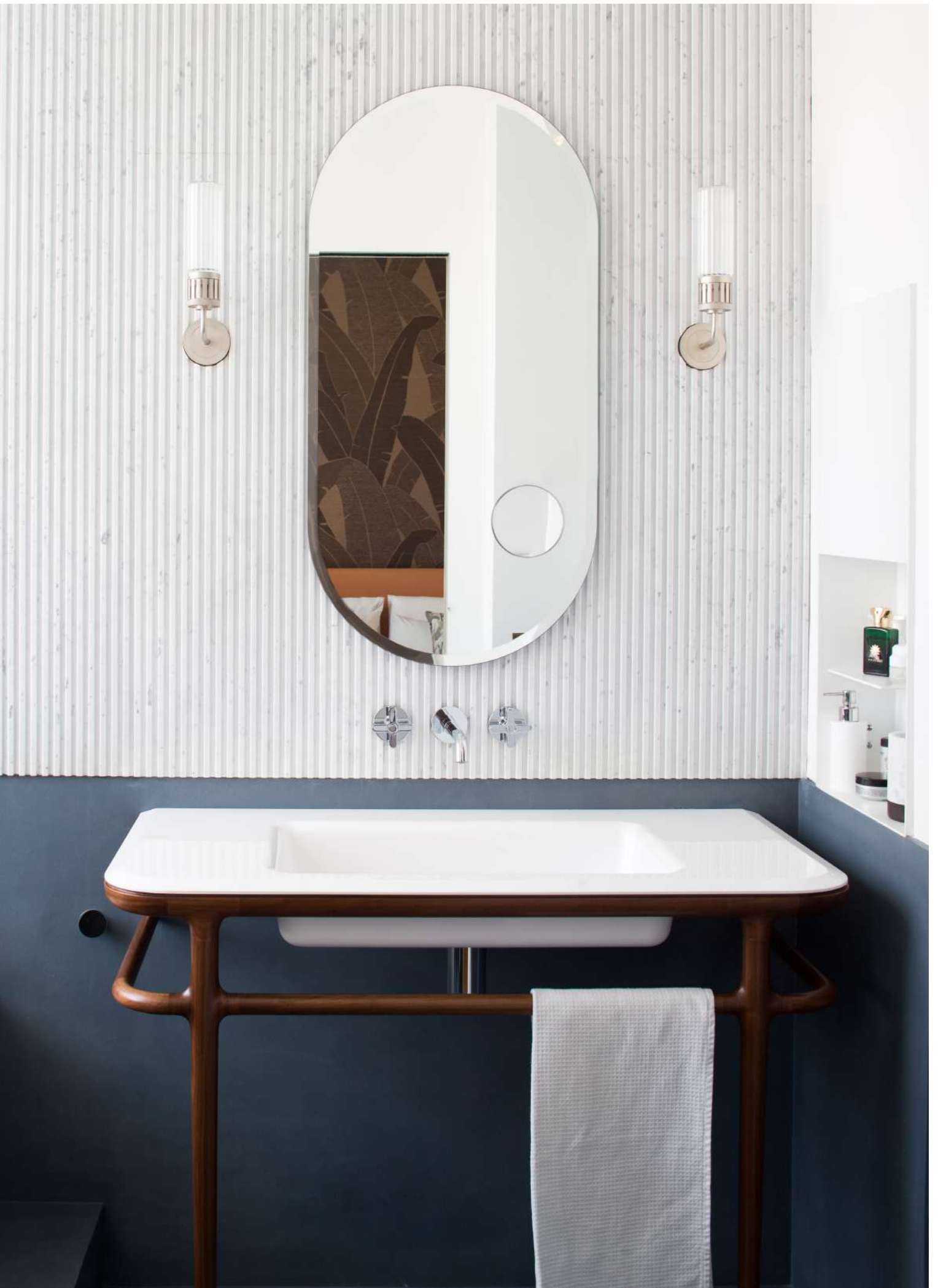



5

**nebra** | vassoio in ceramica *ceramic tray*

Particolare vassoio in ottone e ceramica con illuminazione integrata. Nato dalla necessità dell'alta ristorazione Meneghina per il servizio della piccola pasticceria Nebra presenta al suo interno un led nascosto in grado di illuminare il piano in ceramica enfatizzando romanticamente il termine del pasto. Un'etereo disco di luce.

*Particular brass and ceramic tray with integrated lighting. Born from the need of Milanese haute cuisine for the service of the small pastry Nebra has inside a hidden LED able to illuminate the ceramic top romantically emphasizing the end of the dinner. An ethereal disc of light.*

Ø 24 x 4 cm

lights off



lights on





ENTRYWAYS OF MILAN INGRESSI DI MILANO  
PITTURA SCULTURA FUTURISTE VALLECOCHI

6

**slice** | vasi in marmo *marble vases*

Serie di vasi in marmo realizzati valorizzando gli esuberi di materiale dando nuova preziosa vita a componenti di risulta.  
*Custom made by Casone per FANTIBOZZETTIMENEGON.*

*Series of marble vases made by valuing surplus material giving new precious life to resulting components.*  
*Custom made by Casone for FANTIBOZZETTIMENEGON.*

Ø 18 x 30 cm

Ø 18 x 50 cm





---

Nella foto in alto, il set **slice** è abbinato alla nostra consolle **venere**.

*In the picture above, the **slice** set is combined with our **venere** consolle.*





*complementi complements*

7

**andromeda** | libreria *bookcase*

8

**cerbero** | tavolo *table*

9

**comodo** | servo muto *valet stand*

10

**dioniso** | carrello per liquori *liquor trolley*

11

**era** | madia in marmo *marble madia*

12

**kristalia** | credenza in vetro *glass display*

13

**narciso** | consolle, vanity & comodino  
*console, vanity desk & bedside table*

14

**ofiuco** | tavolini e panca *coffee tables and bench*

15

**venere** | consolle & madia *console & sideboard*

16

**vesta** | cabina armadio *closet*



—  
scopri il mondo di  
**andromeda**

*discover the world of  
andromeda*



Z

**andromeda** | libreria *bookcase*

Libreria bifacciale a libera installazione composta da tre diversi moduli abbinabili liberamente per infinite composizioni. Struttura in metallo finitura ottone bronzato e ripiani in marmo, legno o laccati.

*Free-standing double-sided bookcase composed of three different modules that can be freely combined for infinite compositions. Metal structure with bronzed brass finish and marble, wood or lacquered shelves.*

304 x 34 x 180 cm

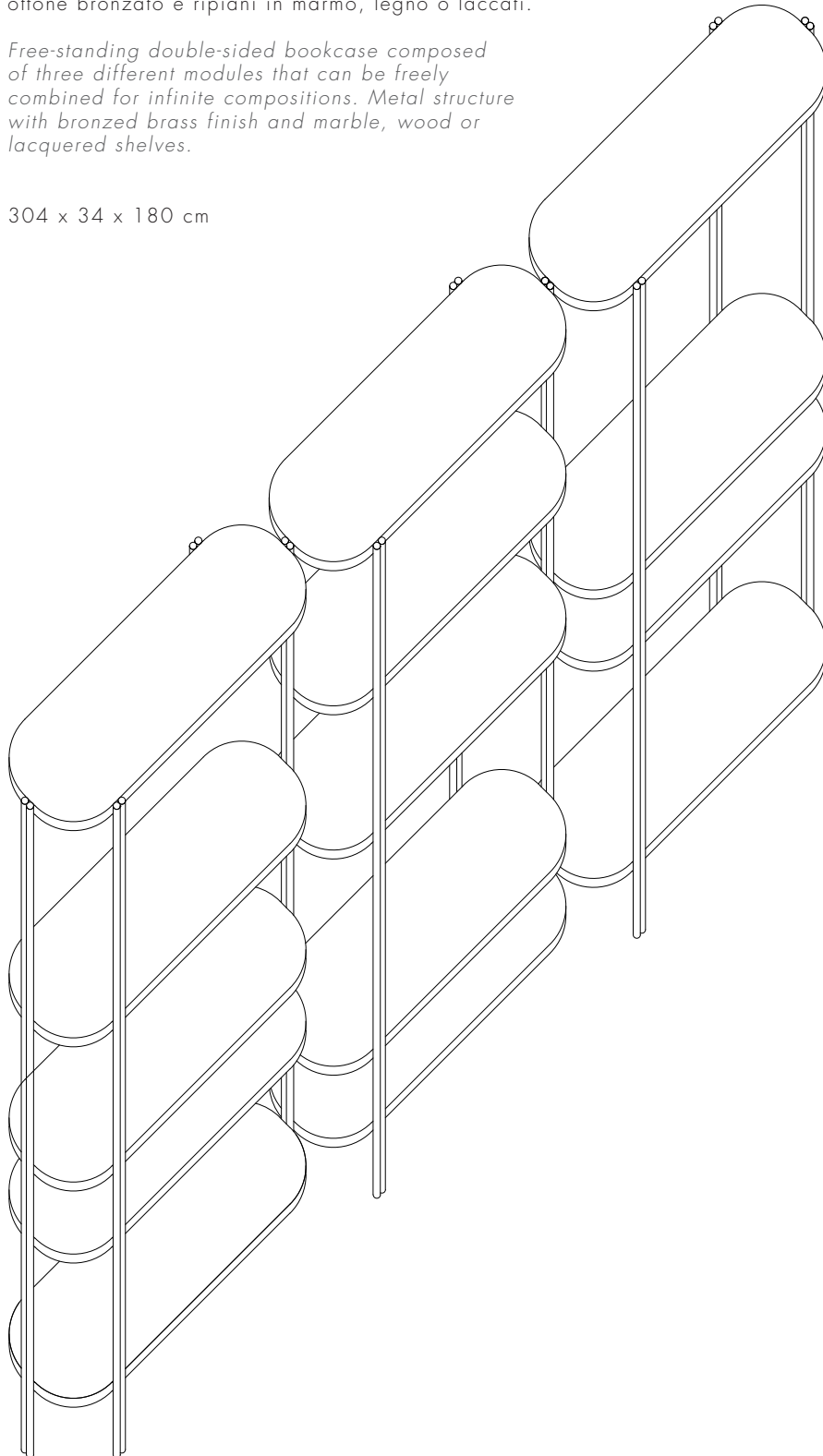





—  
In the picture on this page,  
**andromeda** shelves in  
iranian travertine.

*In the picture on this page,  
**andromeda** shelves in  
iranian travertine.*





8

**cerbero | tavolo da pranzo *dining table***

Tavolo da pranzo con piano in marmo bisellato e particolari gambe in finitura ottone bronzato con appoggio a terra svasato.

*Dining table with bevelled marble top and special legs structure in bronzed brass finish with countersunk ground support.*

280 x 95 x 73 cm







31

—  
**cerbero | tavolo da ufficio office desk**

Office desk con piano in marmo bisellato e particolari gambe in finitura ottone bronzato con appoggio a terra svasato. Le gambe, cave, fungono anche da contenitori per gli accessori: un sistema a lift permette di elevare i dischi in ottone presenti sulla superficie di marmo svelando le tre diverse funzioni, una colonna per le prese dati ed elettriche, una lampada da piano ed un contenitore per acqua e liquori.

*Office desk with bevelled marble top and special legs in bronzed brass finish with countersunk ground support. The hollow legs also serve as containers for accessories: A lift system allows to elevate the brass discs present on the marble surface revealing the three different functions, a column for data and electrical sockets, a floor lamp and a container for water and liquor.*

280 x 95 x 73 cm



---

La forza di questo tavolo risiede nelle sue gambe massicce ma delicate, caratteristica dovuta ai suoi tagli netti che conferiscono a **cerbero** un dettaglio peculiare.

*The power of this table lies in its massive but delicate legs, a characteristic due to its clean cuts which give **cerbero** a peculiar detail.*

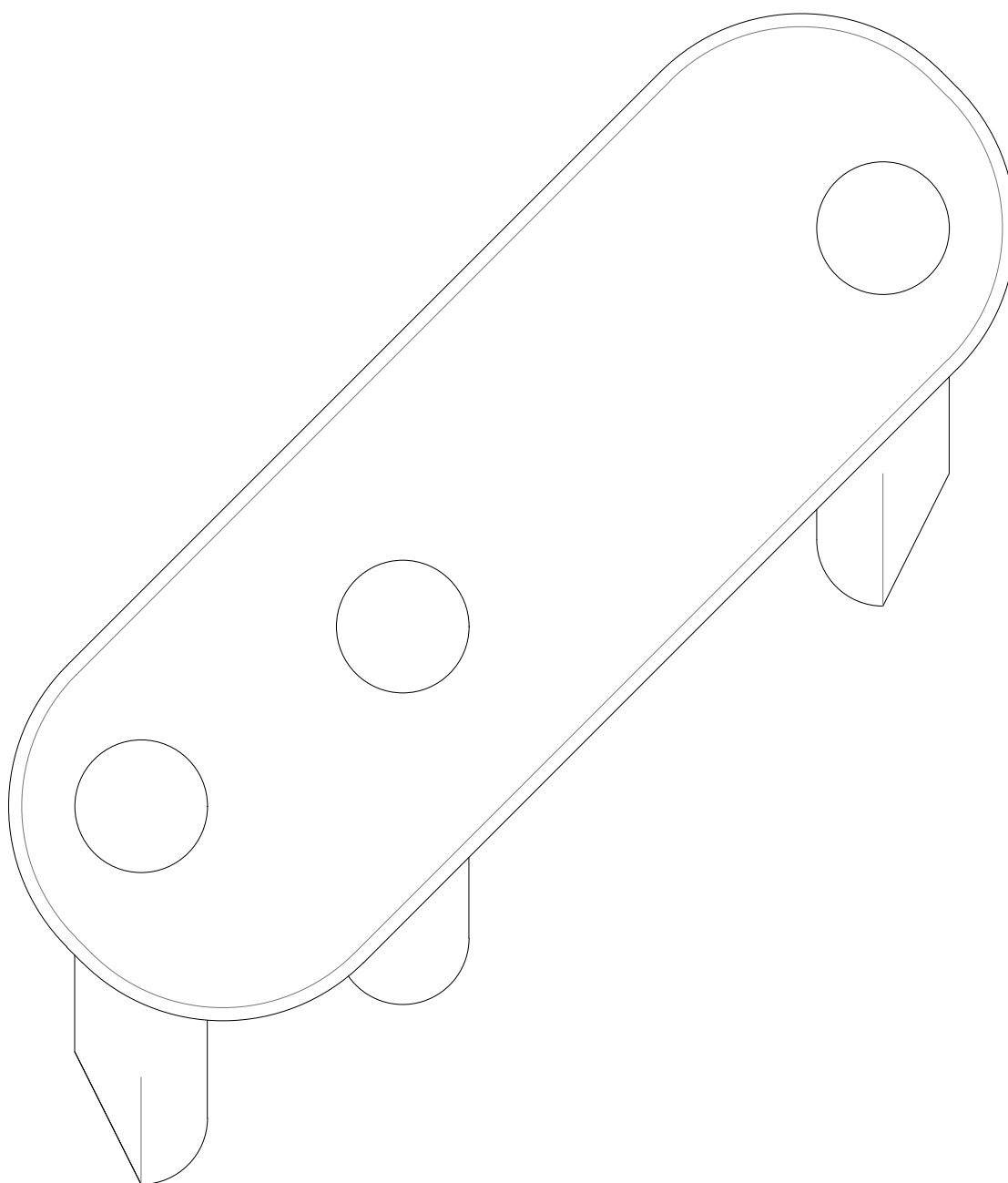







9

**comodo** | servo muto valet stand

La rivisitazione del classico servo muto. Un basamento in legno nasconde al suo interno delle ruote a sfera per una semplice movimentazione ed un pratico cassetto. Gli accessori che si possono fissare alla struttura variano da piccoli vassoi in pelle allo specchio ingranditore.

*The reinterpretation of a classic valet stand. A wooden base hides ball wheels inside for an easy handling and a practical drawer. The accessories that can be attached to the structure vary from small leather trays to the magnifying mirror.*

70 x 35 x 120 cm

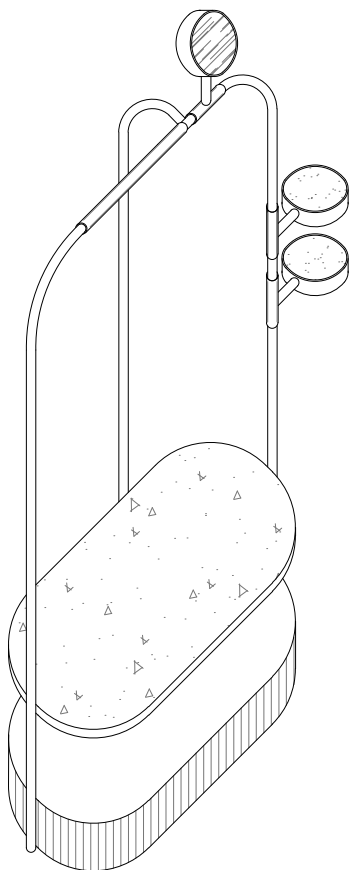

37



10

dioniso | uno one

Nato per la ristorazione, questo carrello per liquori in metallo in finitura ottone e nero ha delle pratiche ruote nascoste ed un ripiano in ceramica.

*Born for catering, this liquor trolley in bronzed and black metal finish has practical hidden ball wheels and a ceramic shelf.*

90 x 40 x 85 cm

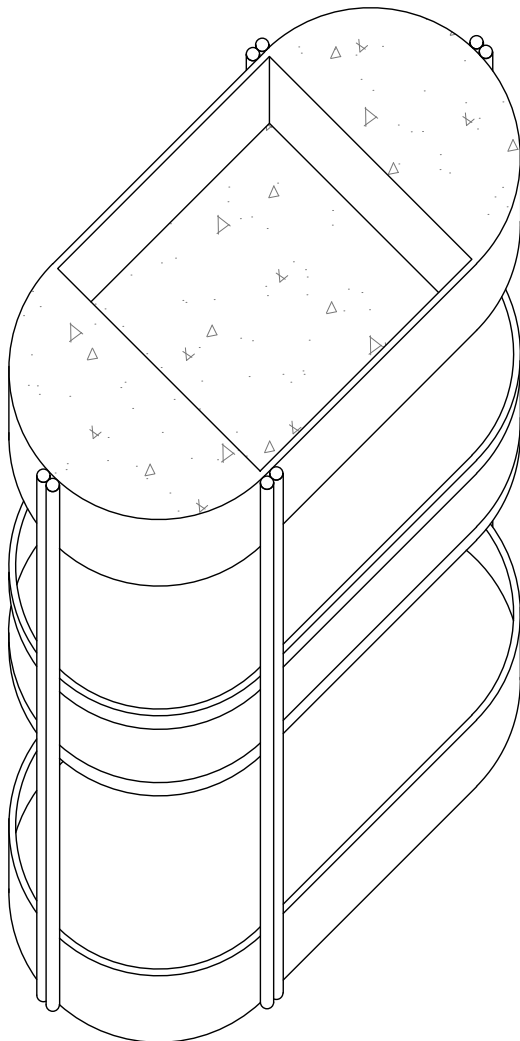





---

dioniso | due two

Nato per la ristorazione, questo carrello per liquori in metallo in finitura ottone e nero ha delle pratiche ruote a sfera nascoste ed un ripiano in ceramica. Una particolare serrandina scorrevole permette di aprire e chiudere il modulo contenitore nella parte bassa.

*Born for catering, this liquor trolley in bronzed and black metal finish has practical hidden ball wheels and a ceramic shelf. A special sliding shutter allows you to open and close the container module in the lower part.*

90 x 40 x 85 cm

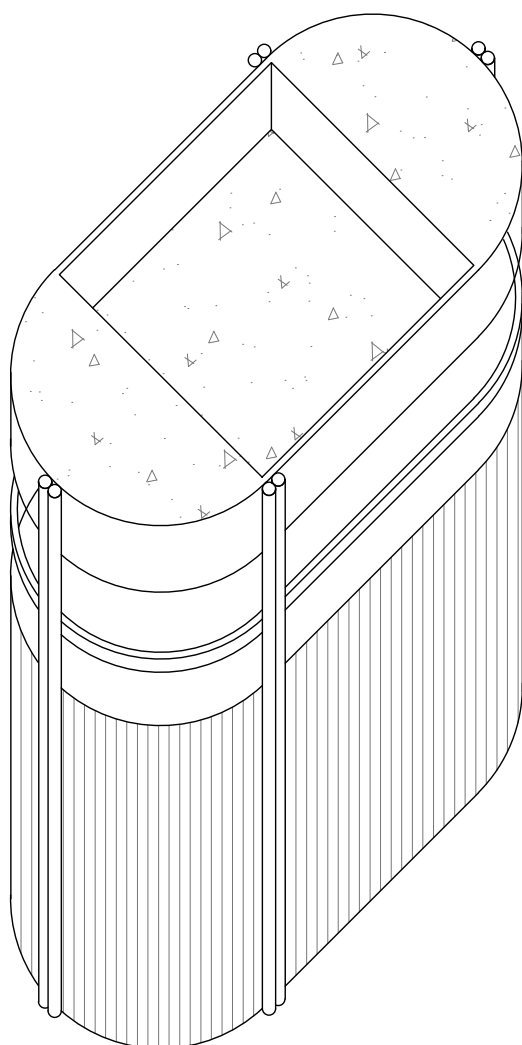

---

dioniso | tre three

Carello per liquori in metallo in finitura ottone e nero con pratiche ruote a sfera invisibili e ripiano in marmo.

*Liquor trolley in bronzed and black metal finish with practical invisible ball wheels and marble shelf.*

70 x 35 x 85 cm

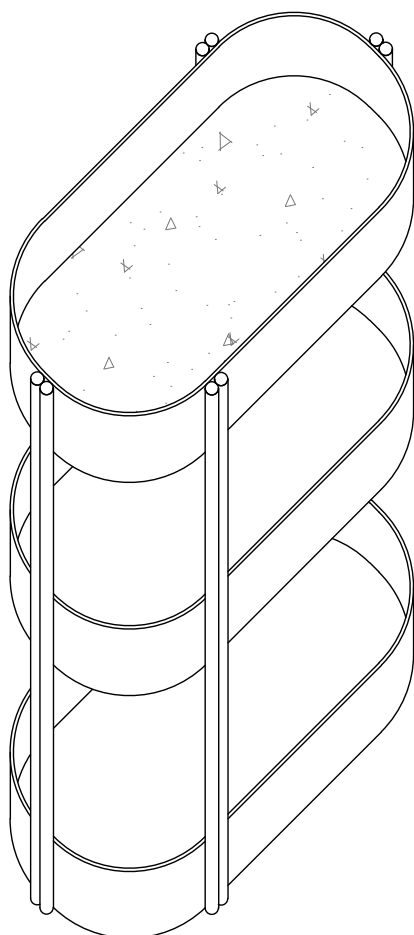





—  
era





**era** | madia in marmo *marble madia*

La forma della madia ERA sottolinea l'alta qualità della lavorazione artigianale. Le ante, un marchio di fabbrica, sono costituite da sottili doghe di marmo che scorrono fluide lungo il binario tagliato con precisione, richiamando la sensazione di una scrivania roll-top ma senza gli inconvenienti del delicato vintage. Una volta aperta, gli interni sono realizzati in raffinato noce canaletto e pelle bordeaux. Le particolari ante scorrevoli permettono di lasciare la credenza semiaperta trasformandola in un espositore a giorno.

Disponibile in otto diverse varianti di marmo.

*The ERA sideboard shape underlines the high quality of the craftsmanship. The doors, a trademark, are made of thin slats of marble that slide fluidly along the precisely cut track, recalling the feel of a roll-top desk but without the drawbacks of delicate vintage. Once opened, the interiors are made of refined ash oak and claret leather. The particular sliding doors allow to leave the sideboards half-open turning it into an open display. Available in eight different marble variants.*

220 x 54 x 72 cm

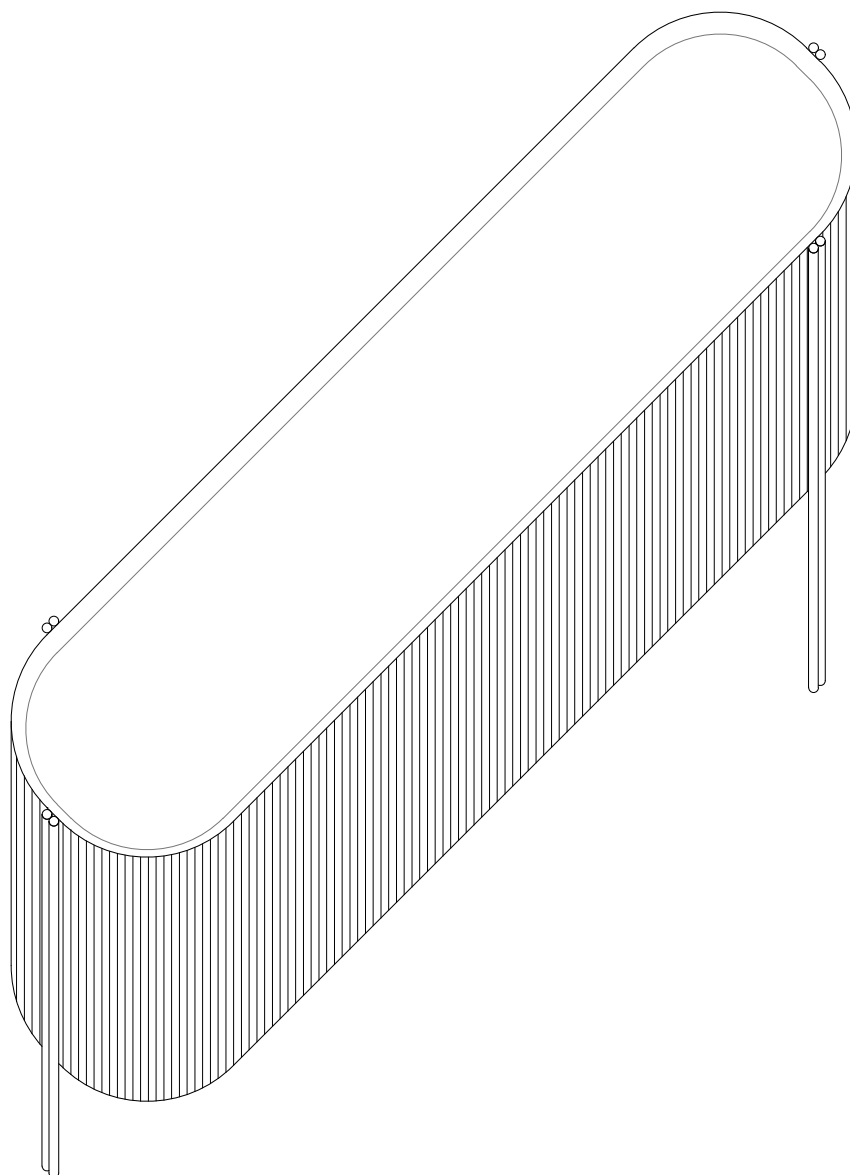



48

---

Nella fotografia sopra,  
**era** in silk georgette con  
interni in pelle bordeaux e  
noce canaletto.

*In the picture on this page,  
**era** in silk georgette marble,  
interior in burgundy leather  
and canaletto walnut wood.*

12

**kristalia** | credenza in vetro *glass display*

Credenza in vetro cannettato curvo con ante scorrevoli. La struttura in metallo finitura ottone bronzaro sostiene l'elemento in vetro e lo protegge, i ripiani interni sono anch'essi in vetro.

*Curved ribbed glass sideboard with sliding doors. The structure in bronzed brass metal finish supports the glass element and designs it, the internal shelves are also made of glass.*

100 x 34 x 135 cm

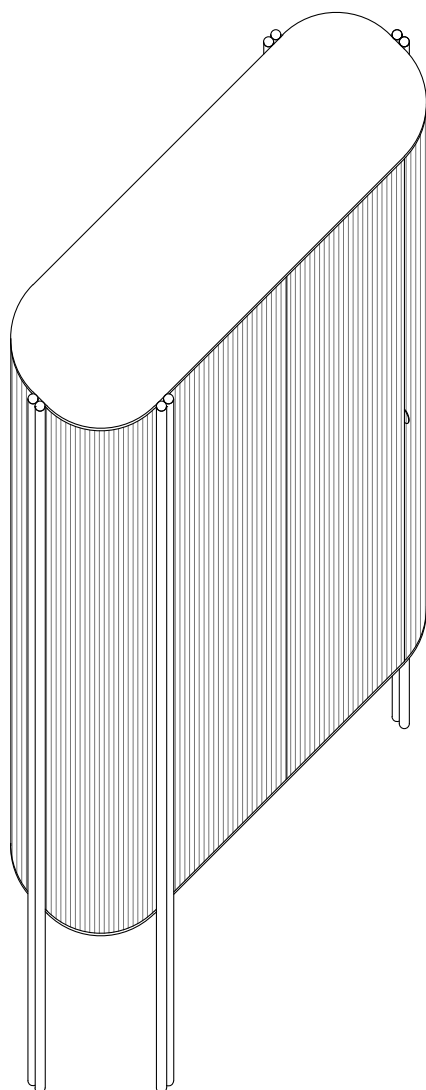



50



—  
credenza in vetro  
**kristalia**

*glass display*  
*kristalia*



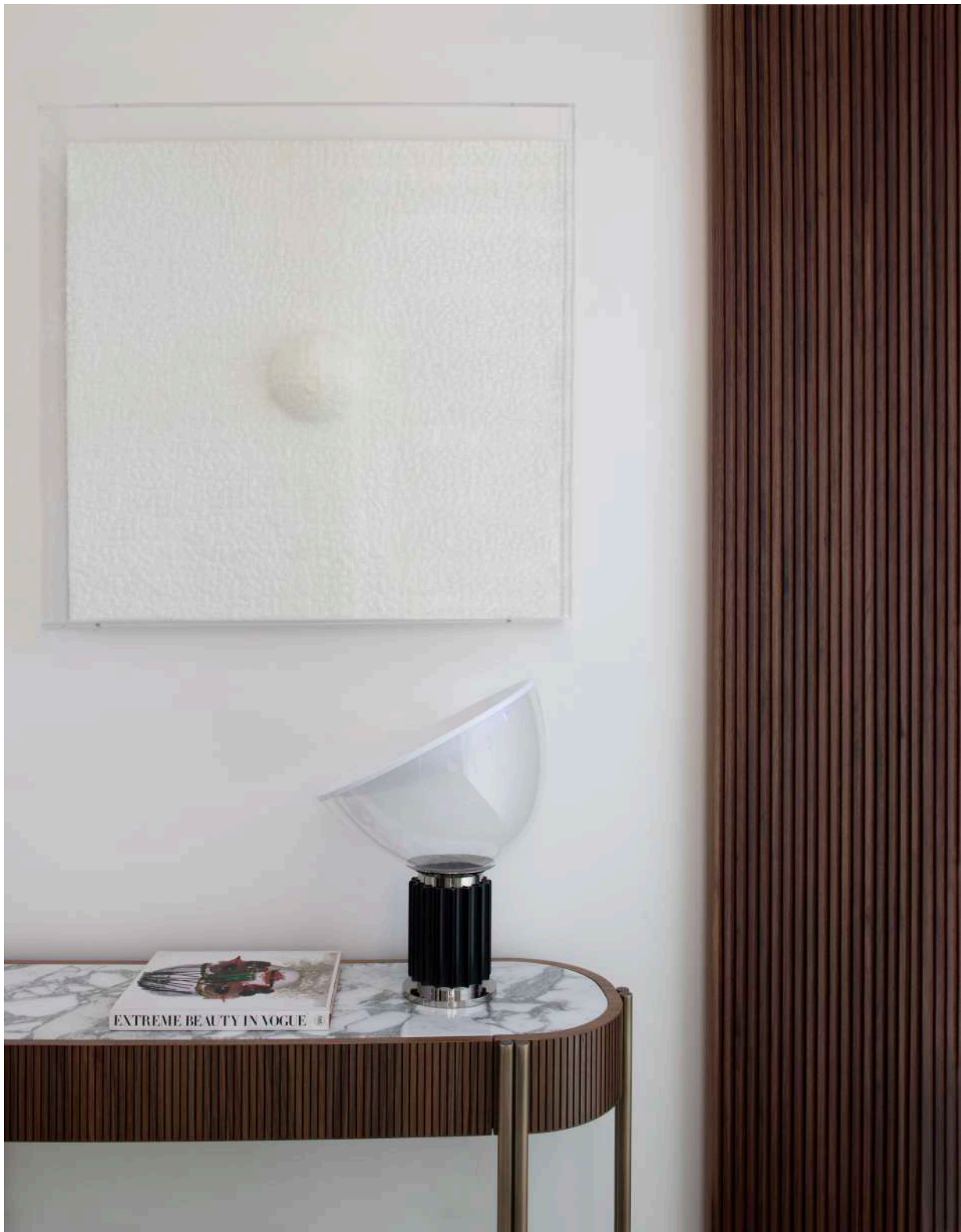

13

**narciso** | consolle console

Consolle con struttura in ottone bronzato, modulo cassetto invisibile in noce canaletto cannettato e piano in marmo.

*Console with bronzed brass structure, invisible drawer module in ribbed canaletto walnut and marble top.*

120 x 35 x 90 cm

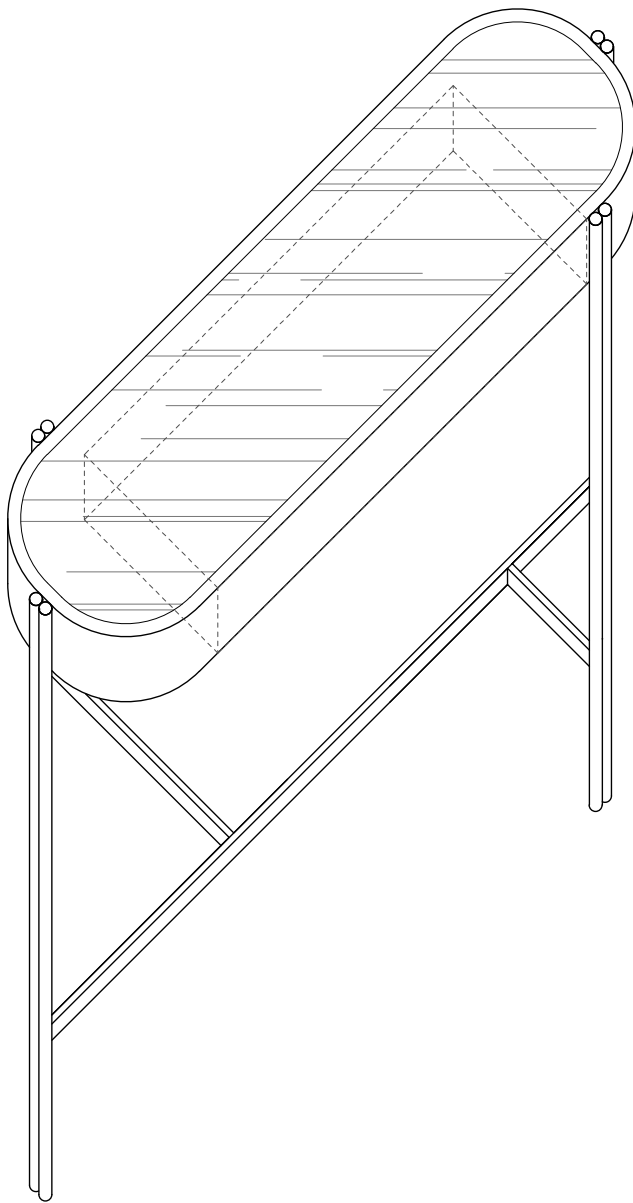

—  
**narciso** consolle

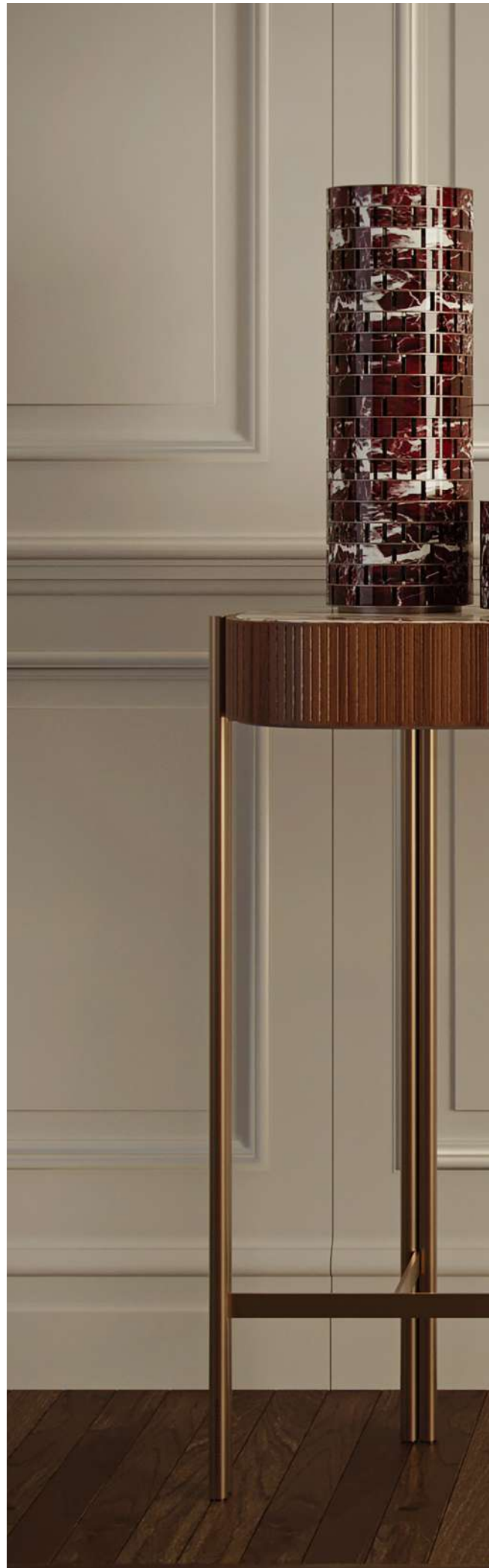





---

vanity desk narciso

---

**narciso** | vanity vanity desk

Vanity desk con frontale in noce canaletto, cassetto nascosto e pratica cassetiera laterale.

*Vanity desk with Canaletto ribbed walnut front, hidden drawer and practical side chest of drawers.*

207 x 45 x 73 cm

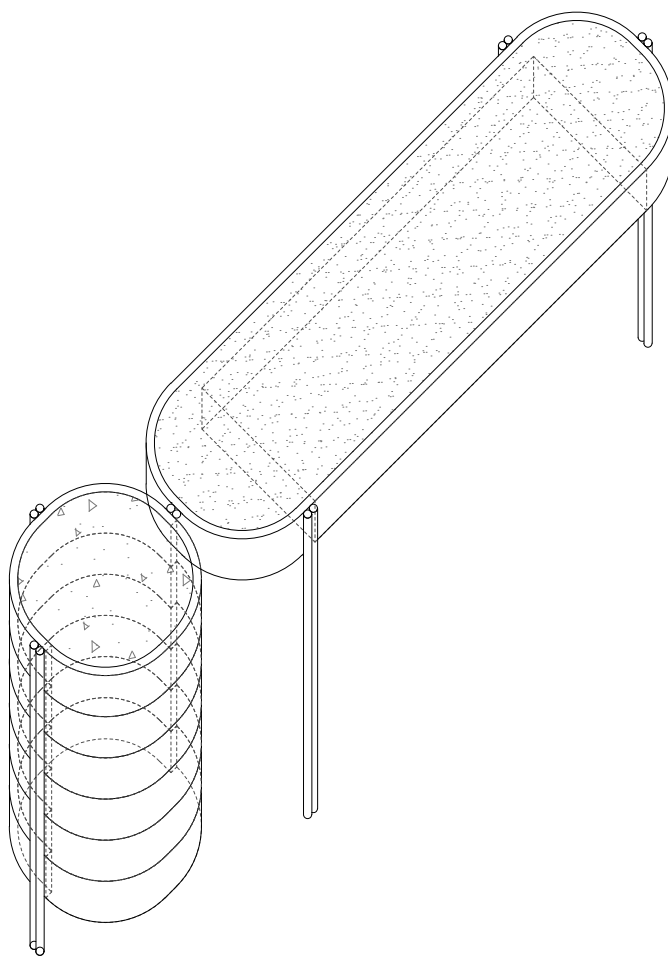

Il ripiano della cassetiera è in marmo mentre il piano dello scrittoio è in morbida pelle. La struttura in ottone bronzato diventa la pratica maniglia della cassetiera.

*The shelf of the chest of drawers is in marble while the top of the desk is in soft leather. The bronzed brass structure becomes the practical handle of the chest of drawers.*





---

dettagli della vanity  
**narciso**

*details of the vanity desk*  
**narciso**



—  
narciso | comodino *bedside table*

Comodino con struttura in ottone bronzato, modulo cassetto in noce canaletto cannettato e ripiano superiore in marmo.

*Bedside table with bronzed brass structure, drawer module in ribbed walnut channels and upper shelf in marble.*

60 x 35 x 40 cm

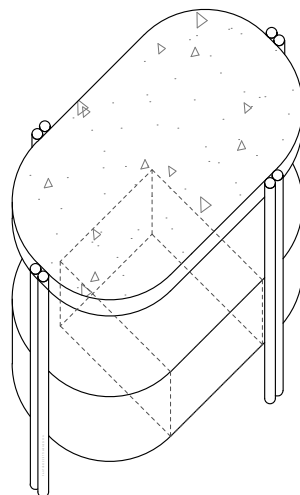



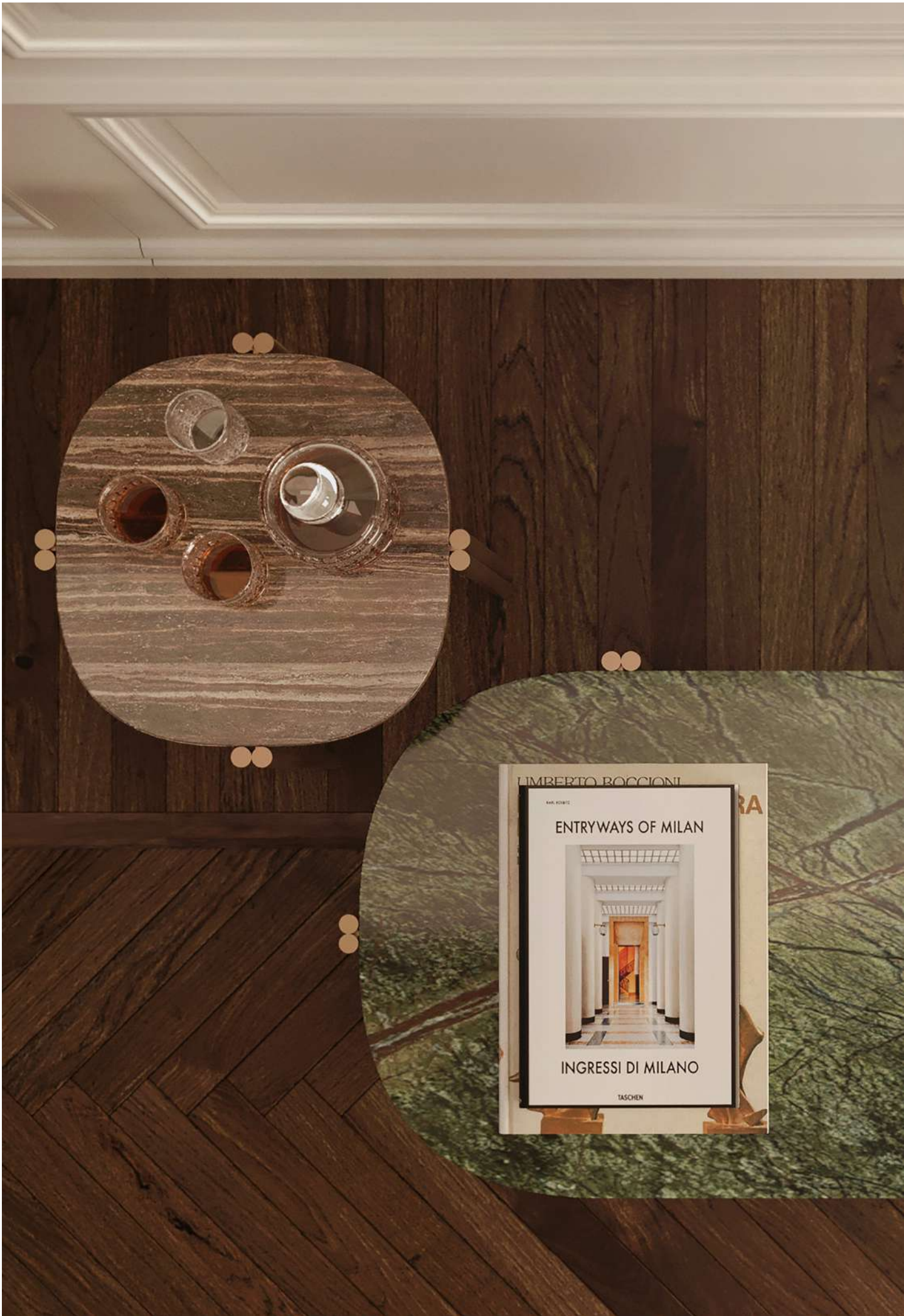

14

**ofiuco** | tavolini *coffee tables*

Serie di tavolini da salotto in marmo ed ottone bronzato. La particolare struttura asimmetrica delle gambe enfatizza la sensazione di leggerezza del prodotto lasciando apprezzare lo spessore del marmo.

*Series of coffee tables in marble and bronzed brass. The particular asymmetric structure of the legs emphasizes the feeling of lightness of the product, allowing the thickness of the marble to be appreciated.*

MIN 44 x 44 x 50 cm  
MID 120 x 54 x 30 cm

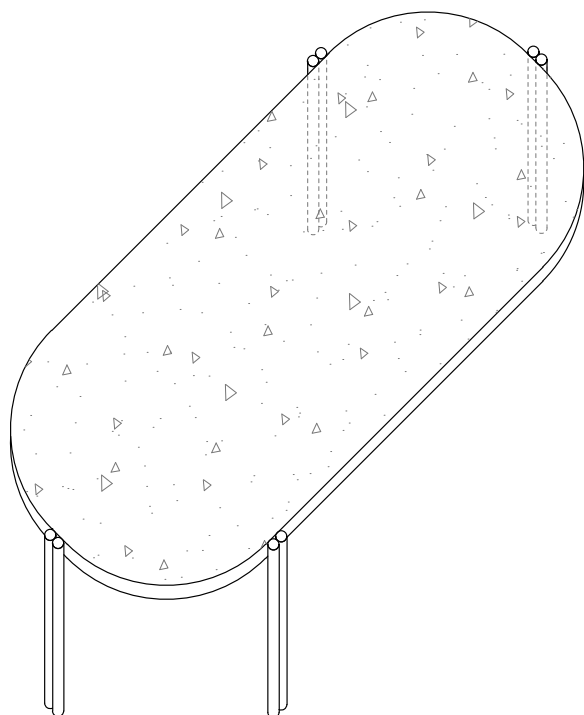
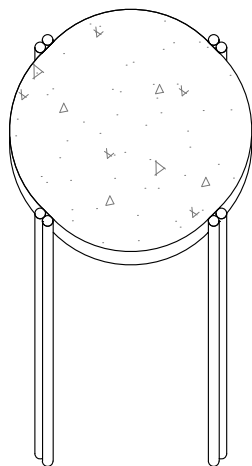



Nella foto qui sopra,  
**ofiuco** piccolo e **ofiuco** medio.

*In the picture on this page,  
**ofiuco** small and **ofiuco** medium.*



—  
ofiuco | tavolini *coffee tables*

LARGE 180 x 90 x 25 cm

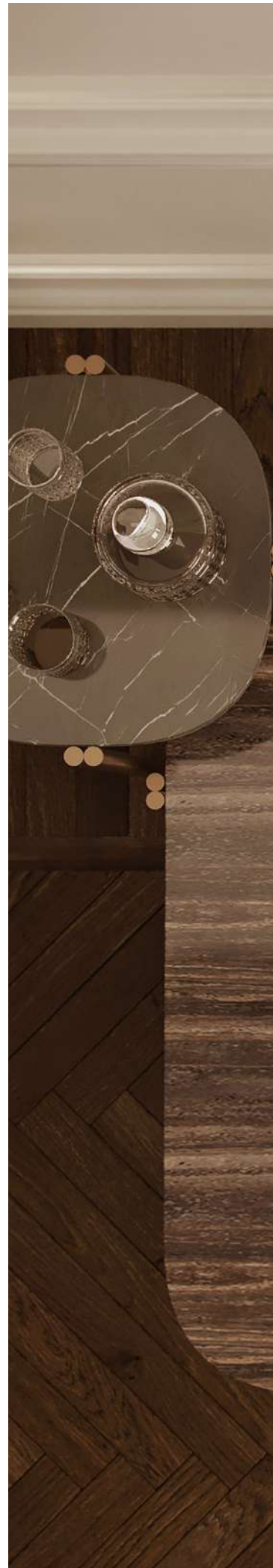
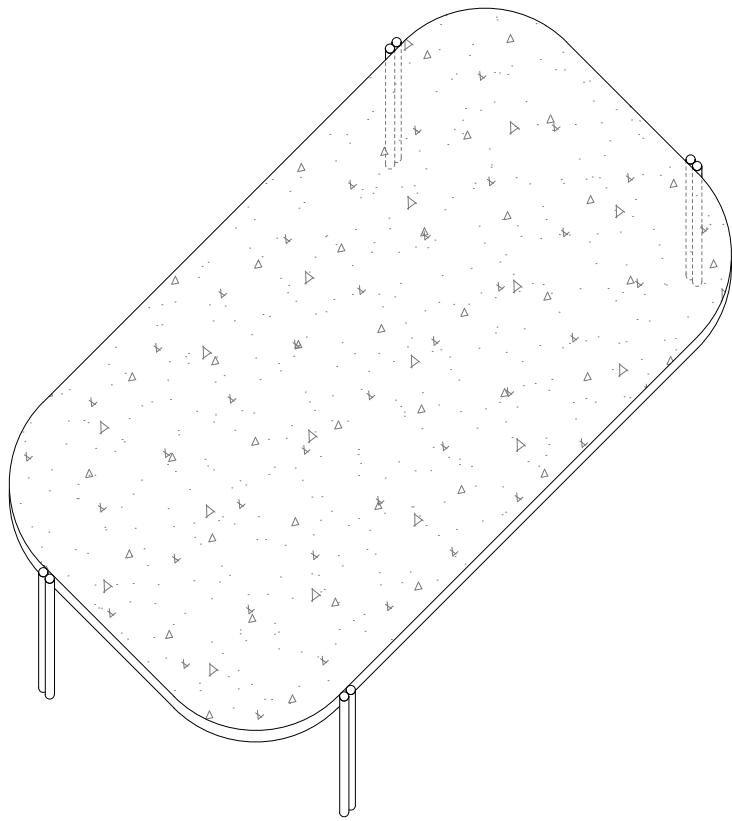





Nelle foto qui sopra e a destra,  
**ofiuco** piccolo e **ofiuco** grande.

*In the pictures on this page and on the right,  
**ofiuco** small and **ofiuco** large.*



ENTRYWAYS OF MILAN INGRESSI DI MILANO

LIBROCCINI PITTURA SCULTURA FUTURISTE VALLEGGI



---

ofiuco | panca bench

Panca in marmo ed ottone bronzato. La particolare struttura asimmetrica delle gambe enfatizza la sensazione di leggerezza del prodotto lasciando apprezzare lo spessore del marmo, un morbido cuscino in pelle naturale appositamente dimensionato funge da punto di seduta.

*Marble bench with bronzed brass structure. The particular asymmetric structure of the legs emphasizes the feeling of lightness of the product, allowing the thickness of the marble to be appreciated a soft cushion in specially sized natural leather acts as a seat.*

120 x 50 x 35 cm

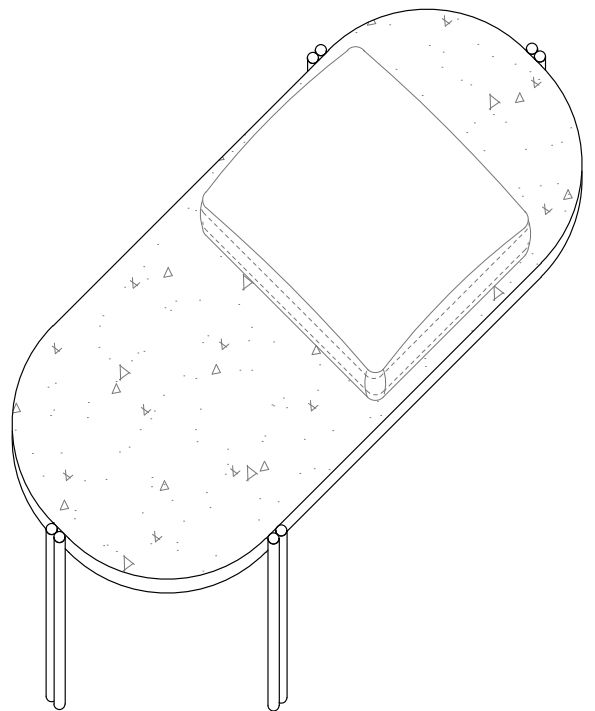

71





72



15

**venere** | consolle *console*

Consolle in ottone bronzato  
con ripiano in marmo.

*Console in bronzed brass with  
marble top.*

160 x 45 x 90 cm



—  
**venere** | *madia sideboard*

Madia in noce canaletto cannettato dotata di sei pratici cassetti e due antine laterali. Ripiano superiore in marmo e struttura in ottone bronzato.

*Ribbed Canaletto walnut sideboard with six practical drawers and two side doors. Top shelf in marble and structure in bronzed brass.*

160 x 45 x 90 cm

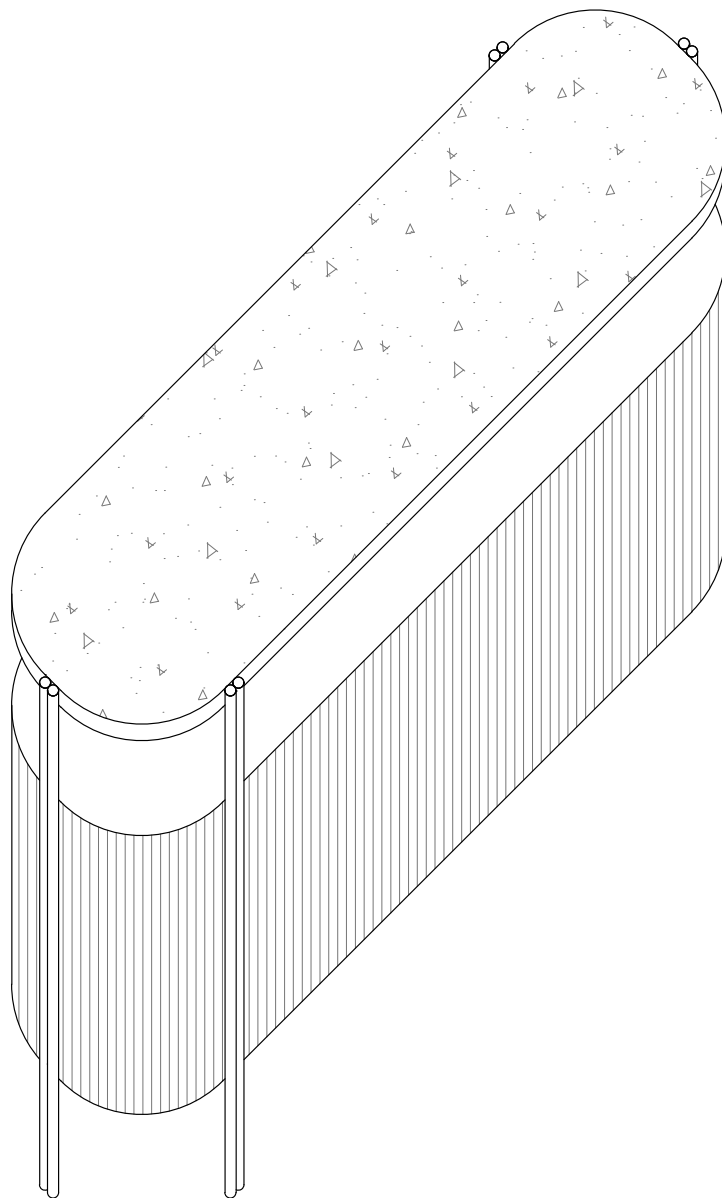





—  
scopri il mondo di  
**vesta**  
*discover the world of*  
**vesta**



16

vesta | cabina armadio *closet*

Cabina armadio, anche in versione bifacciale, dai materiali pregiati che garantiscono un aspetto minimale e sofisticato. La struttura è in metallo finitura ottone bronzato, ripiani centrali in marmo, cassetti in rovere e particolari schienali curvi rivestiti in pelle. Una gamma completa di accessori offre infinite forme di personalizzazione.

*Closet, also in double-sided version, has fine materials guarantee a minimal and sophisticated look. The frame is made of bronzed metal finish, marble trays, walnut ribbed wood drawers and back panel covered with leather. A full range of accessories offer a wide range of personalization solutions.*

632 x 60 x 230 cm

78







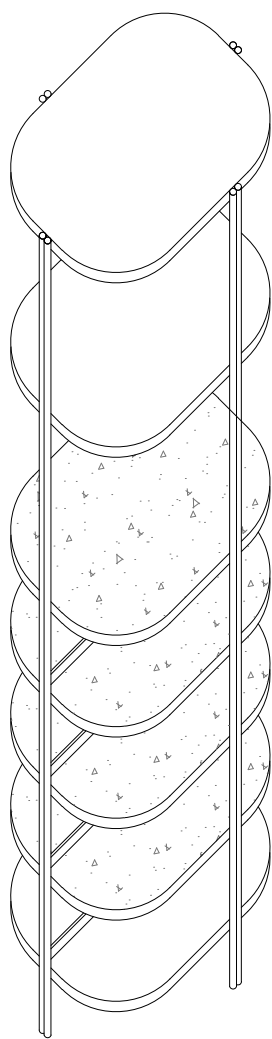

VST\_A

modulo scarpiera con  
elemento  
battitacco per le scarpe  
in ottone;

*shoe rack module with  
solid brass  
shoe-strike element*

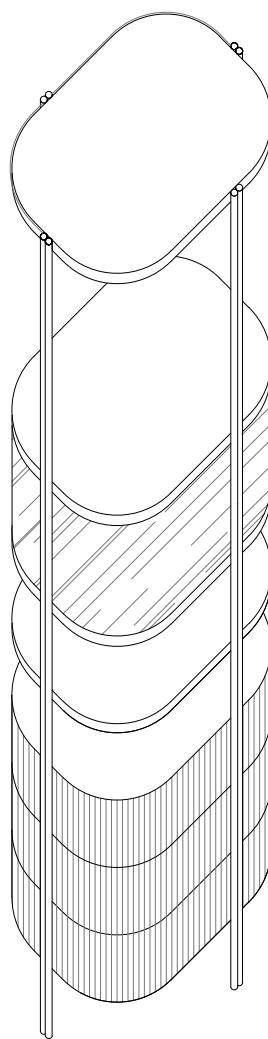

VST\_B

modulo cassetiera in  
legno  
con teca accessori in  
vetro;

*wood drawer module  
with glass  
accessory display case*

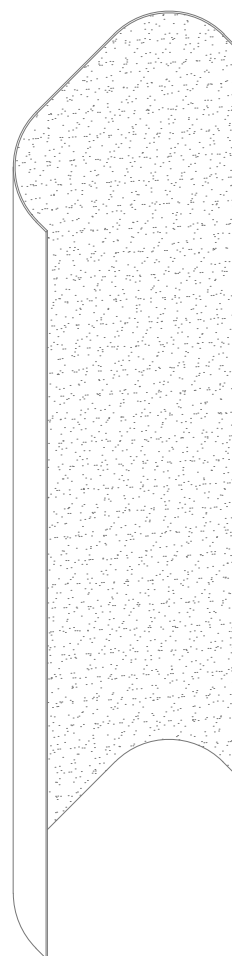

VST\_AP/AV

accessorio schienale in  
pelle (AP) o vetro (AV);

*leather backrest  
accessory (AP) or glass  
(AV)*

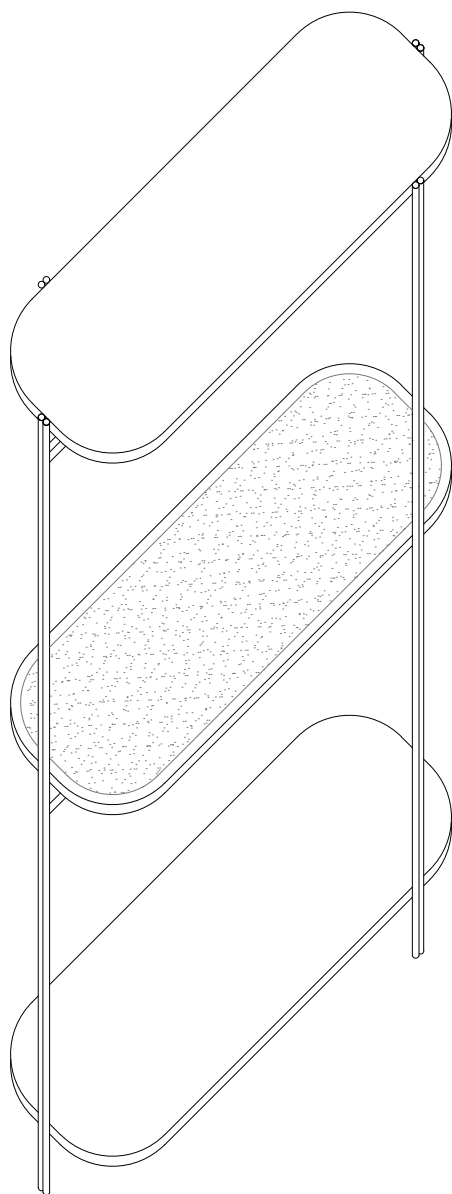



---

**VST\_C**

modulo appendiabite a  
due livelli con  
striscia led inserita nel  
tubo appenderia;

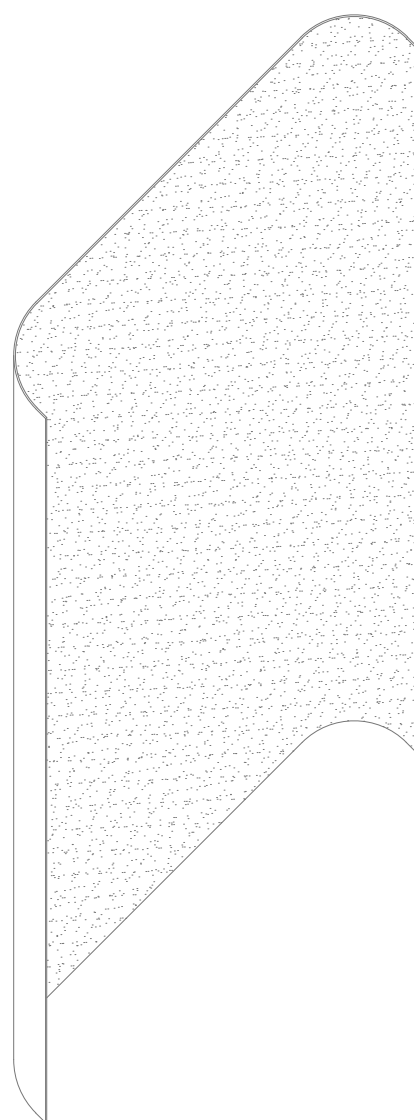
*two-tiered clothing  
hanger module with  
LED strip inserted into the  
hang tube*



---

**VST\_CP/CV**

accessorio schienale in  
pelle (CP) o vetro (CV);

*leather backrest  
accessory (CP) or glass  
(CV)*











---

**marmi *marbles* cat. A**



bianco carrara  
*carrara white*



travertino navona  
*navona travertine*



travertino iraniano  
*iranian travertine*

---

**marmi *marbles* cat. B**



grigio saint laurant  
*gris saint laurant*



calacatta vagli  
*vagli calacatta*



silk georgette  
*silk georgette*

---

marmi *marbles* cat. C



nero sahara  
*sahara noir*



calacatta oro  
*calacatta gold*



verde alpi  
*green alps*

---

CAT. A, categoria base  
CAT. B, categoria media  
CAT.C, categoria alta

- riferito al prezzo

*CAT. A, base category  
CAT. B, medium category  
CAT.C, high category*

- referred to the price

---

le immagini sono  
indicative; le lastre  
saranno selezionate una  
volta scelto il prodotto

*the images are  
indicative; the slabs will  
be selected once the  
product has been chosen*

---

legni woods



noce canaletto  
*canaletto walnut*



rovere borotalco  
*talcum powder oak*



frassino nero  
*black ash*

---

laccati RAL *laquered RAL*

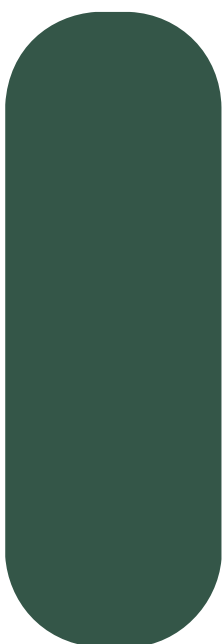

RAL 6028  
lucido o opaco  
*RAL 6028  
glossy or matt*

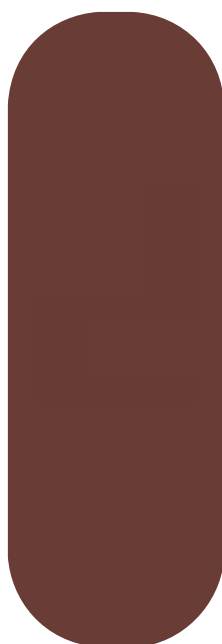

RAL 3009  
lucido o opaco  
*RAL 3009  
glossy or matt*



RAL 7044  
lucido o opaco  
*RAL 7044  
glossy or matt*

---

**pelli** *leathers*



pelle bordeaux  
*burgundy leather*



pelle cognac  
*cognac leather*



pelle polvere  
*dust leather*

---

i legni e i laccati  
si possono avere  
nelle finiture: liscia,  
cannettata, lucida o  
opaca; i colori RAL dei  
laccati sono indicativi:  
si può scegliere il RAL di  
proprio gradimento tra  
tutti i codici;

*the woods and lacquers  
can be in this finishes:  
smooth, ribbed, glossy  
or matt; the RAL colors  
of the lacquers are  
indicative: you can  
choose the RAL of your  
liking from all the codes;*





—  
**accessori accessories**

**2**

**brique** | vasi in marmo *marble vases*

Vaso in dischi di ottone bronzato spazzolato a mano e marmo rosso levanto.

*Vase made of bronzed brass discs and Levanto red marble.*

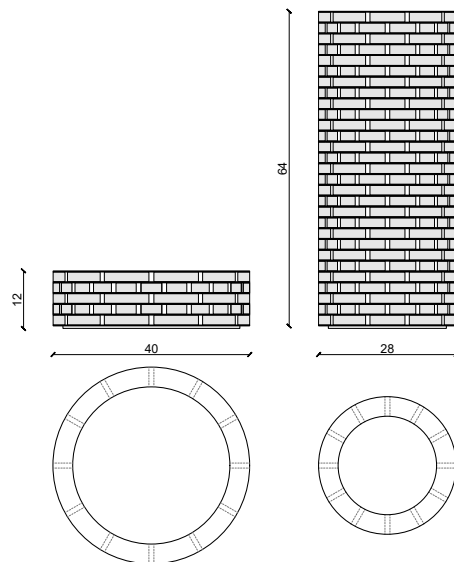

**3**

**contentus** | vasi in ottone *brass tray*

Vassoio in ottone bronzato spazzolato a mano con accessori in ottone e mosaico di marmo removibile.

*Hand-brushed bronzed brass tray with removable marble mosaic and brass accessories.*

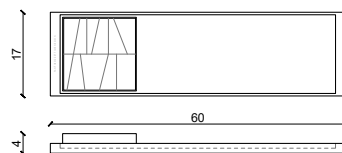

**4**

**narciso** | specchio *mirror*

Specchio ovale con bordo bisellato e magnificatore integrato.

*Oval mirror with beveled edge and integrated magnifying mirror.*

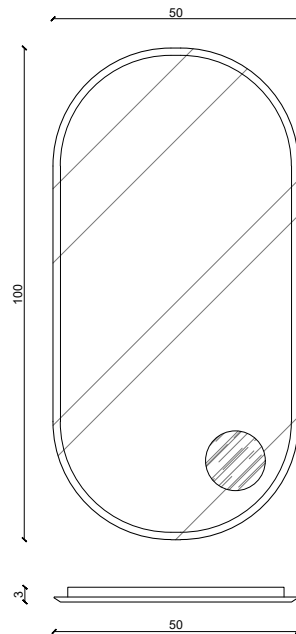

5

**nebra** | vassoio in ceramica *ceramic tray*

Vassoio in ottone bronzato spazzolato a mano con illuminazione integrata e piano in ceramica.

*Tray in hand-brushed bronzed brass with integrated lighting and ceramic top.*

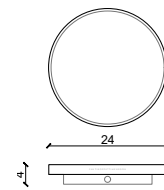

6

**slice** | vasi in marmo *marble vases*

Vaso in fasce concentriche di marmo Verde Alpi e Carrara.

*Vase in concentric bands of Verde Alpi and Carrara marble.*

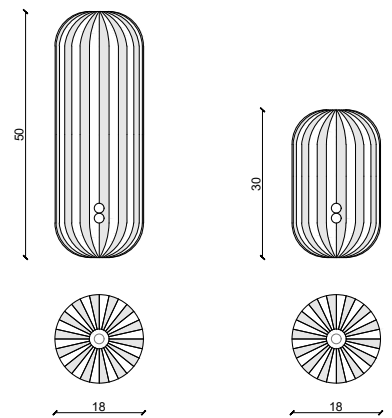

complementi *complements*

7

**andromeda** | libreria *bookcase*

Libreria modulare con ripiani in marmo/legno/laccati e struttura in metallo finitura ottone bronzato.

*Modular bookcase with marble/wood/lacquered shelves and metal structure finished in brushed bronzed brass.*

96

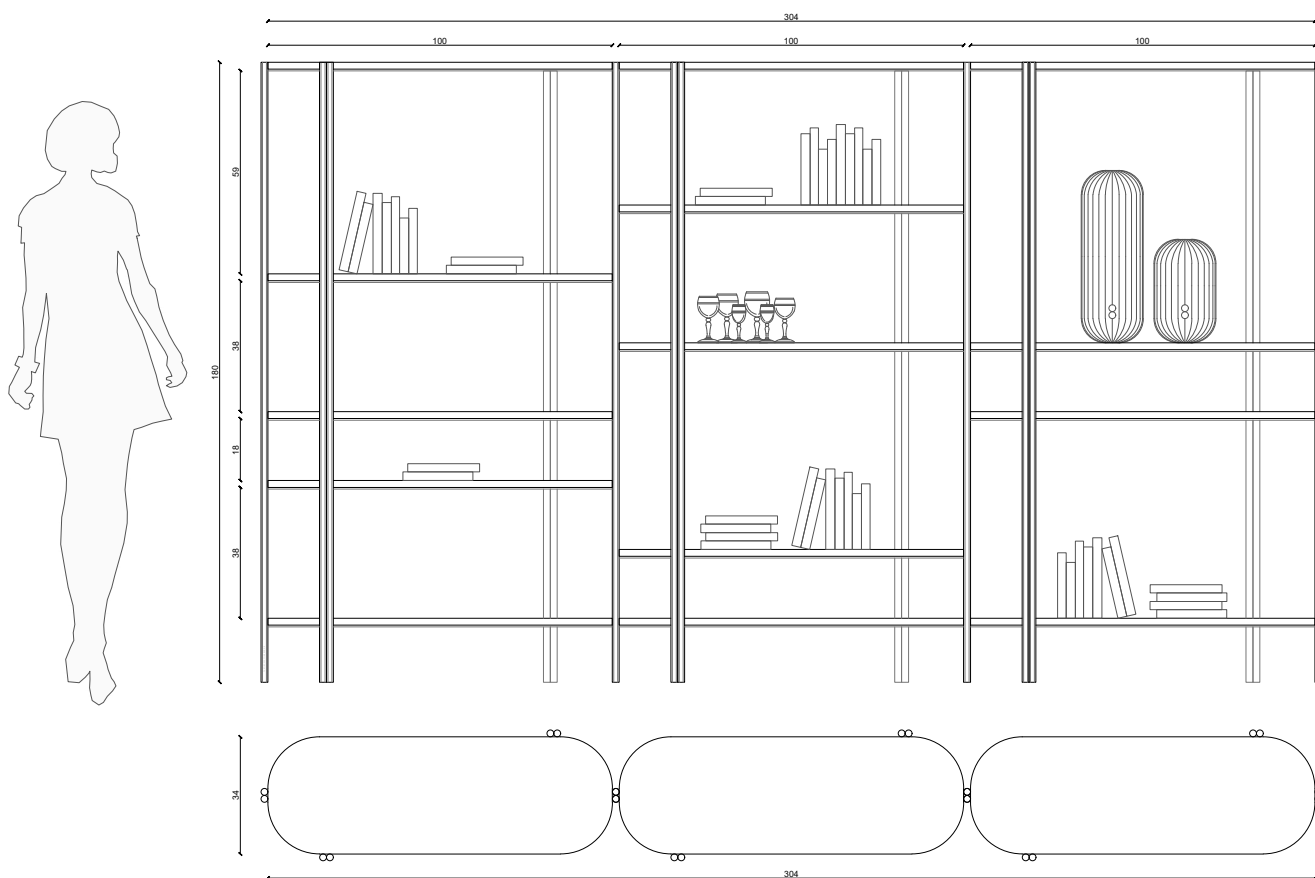

8

**cerbero** | tavolo *table*

Tavolo da pranzo con top in marmo e particolari gambe in finitura ottone bronzato.

*Dining table with marble top and special legs in bronzed brass finish structure.*

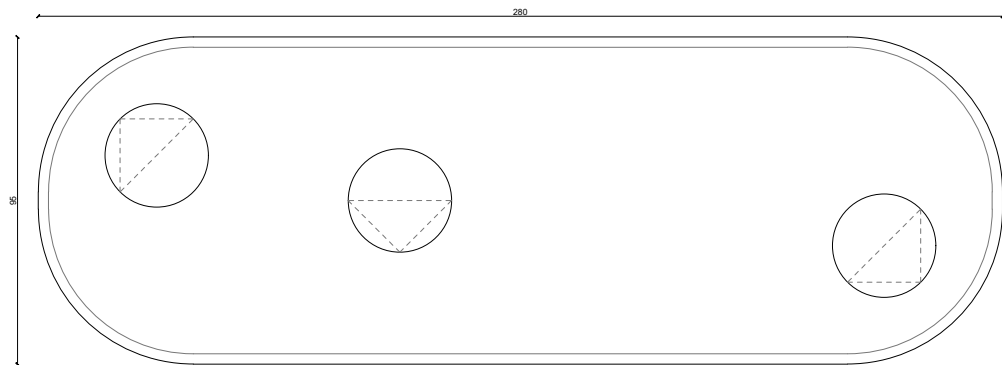
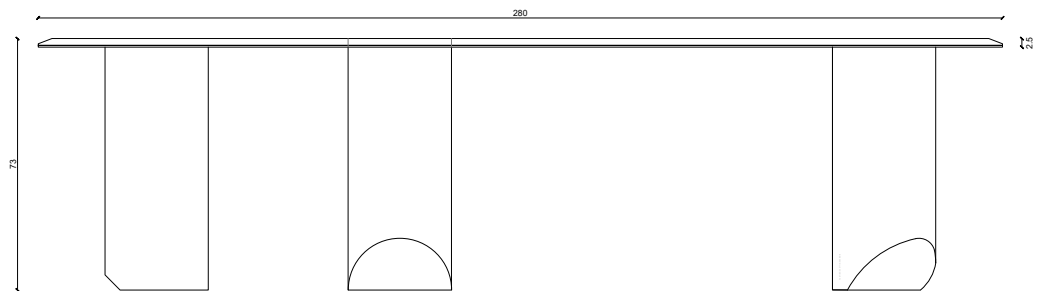

9

comodo | servo muto valet stand

Servomuto in metallo finitura ottone bronzato con ripiano in marmo e ruote a sfera invisibili.

*Bronzed brass metal valet stand with marble shelf and invisible ball-bearing wheels.*

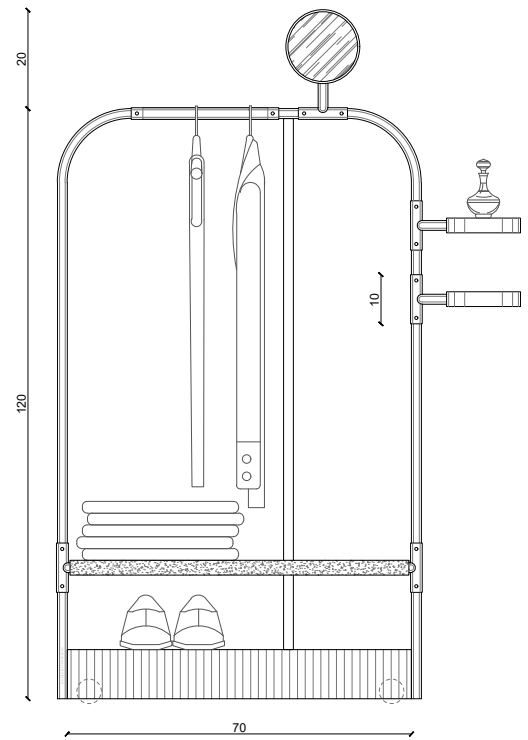
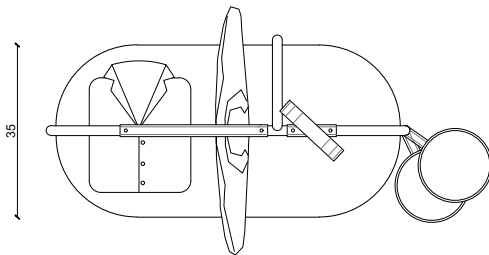

10

dioniso | uno one

Carrello per liquori in metallo  
finitura ottone bronzato con  
piano in ceramica e ruote a sfera  
invisibili.

*Bronzed brass metal drinks trolley  
with ceramic top and concealed  
ball-bearing wheels.*

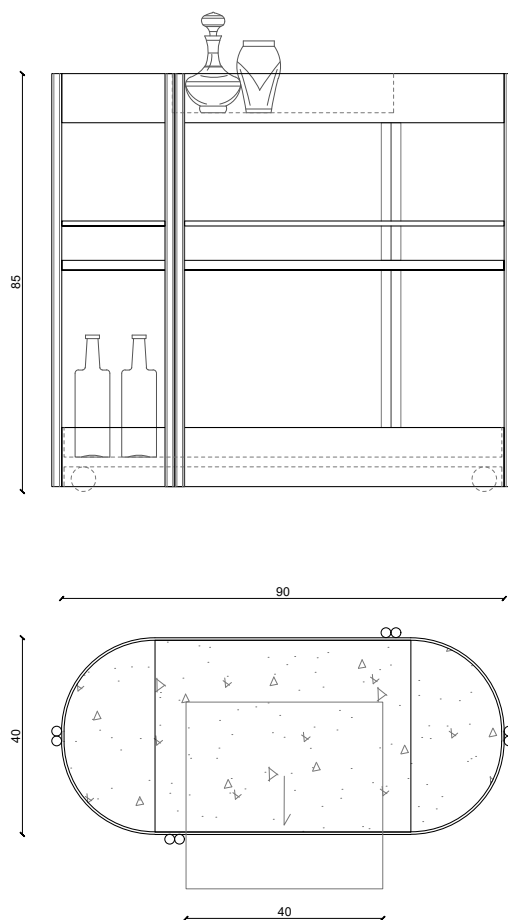

## 10

### dioniso | due two

Carrello per liquori in metallo  
finitura ottone bronzato con  
piano in ceramica e ruote a  
sfera invisibili. Una particolare  
serrandina scorrevole verticale  
permettere di chiudere la parte  
inferiore.

*Bronzed brass metal liquor cart  
with ceramic top and invisible  
ball-bearing wheels. A special  
vertical sliding shutter allows for  
the lower part to be closed.*

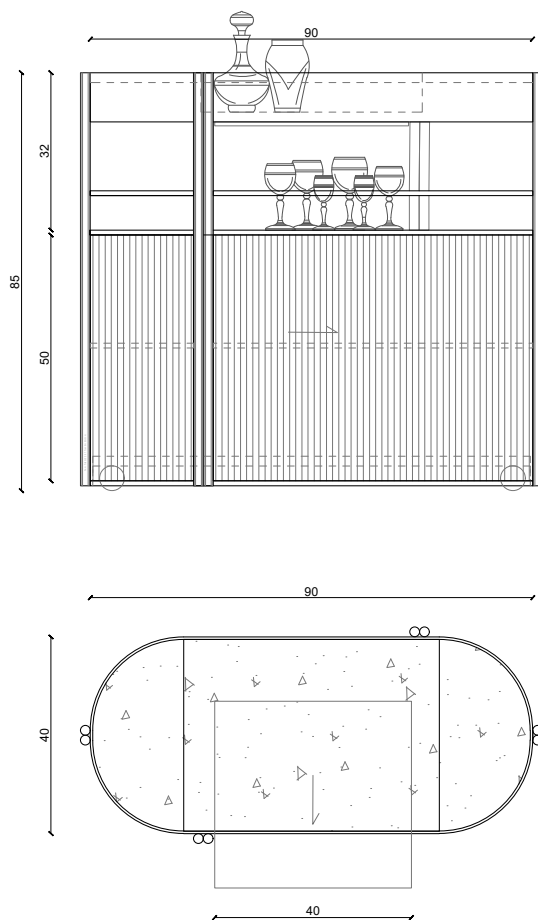

10

dioniso | tre three

Carrello per liquori in metallo  
finitura ottone bronzato con piano  
in marmo e ruote a sfera invisibili.

*Bronzed brass metal trolley  
for drinks with marble top and  
concealed ball-bearing wheels.*

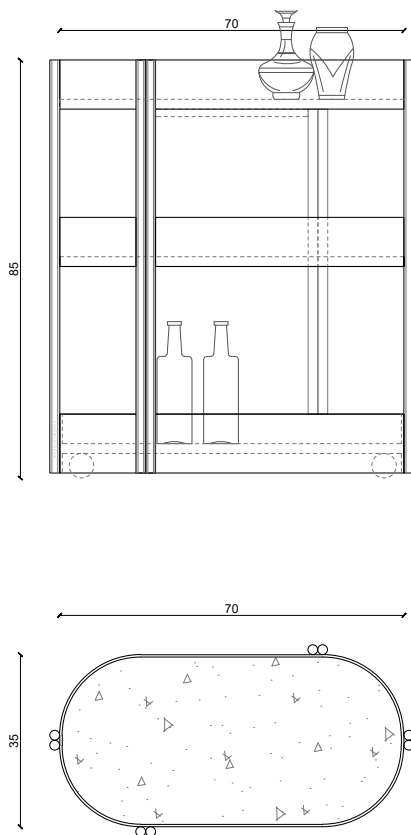

11

**era** | *madia in marmo marble madia*

Madia con top ipogeo in marmo, struttura in ottone bronzato e particolare anta a scorrimento in marmo.

*Sideboard with hypogeum marble top, bronzed brass structure, and a unique ribbed sliding door in marble.*

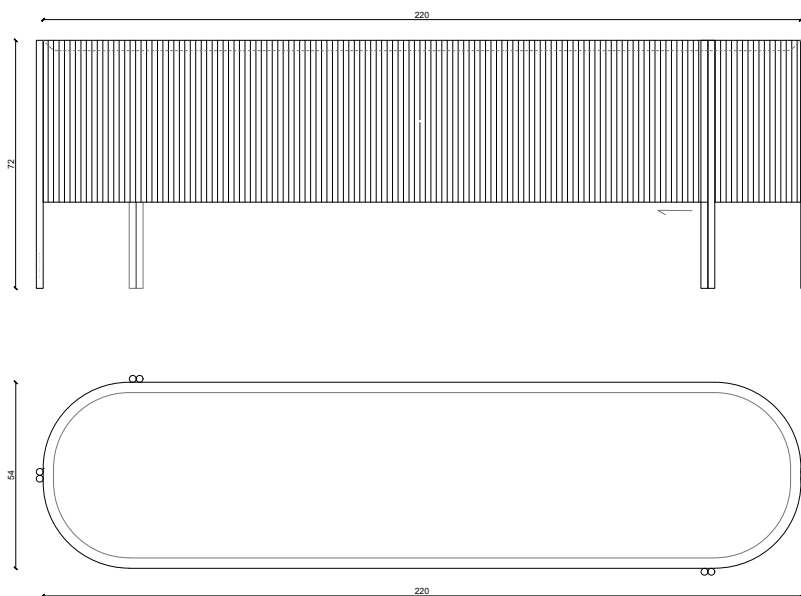

12

**kristalia** | credenza in vetro *glass display*

Madia in vetro cannettato e metallo finitura ottone bronzato.

*Ribbed glass display cabinet and bronzed brass metal finish.*

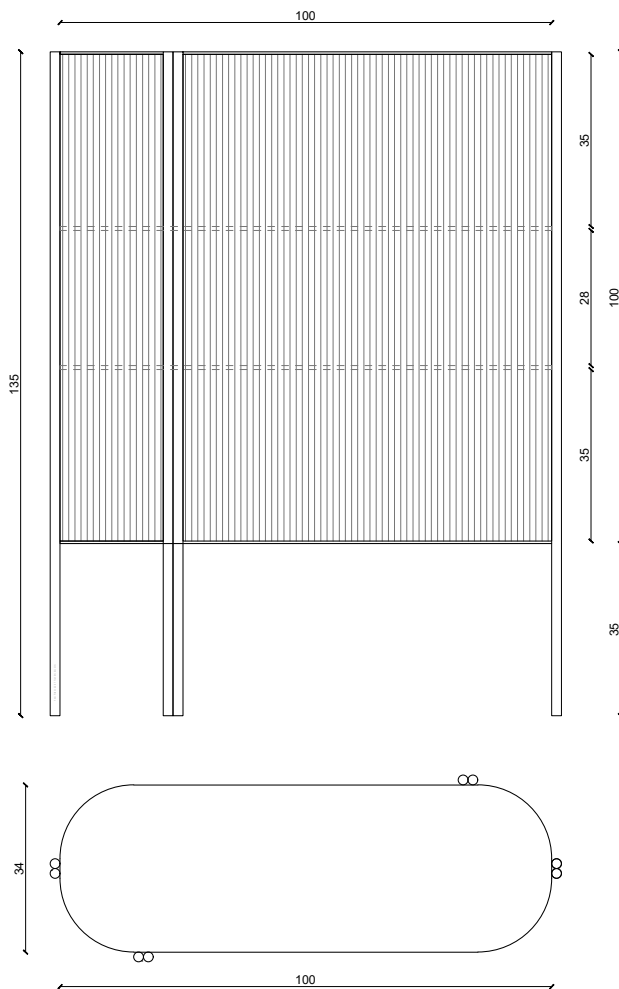

**13**

**narciso | consolle console**

Consolle svuotatasche con  
cassetto nascosto.

*Empty pocket console with hidden  
drawer.*

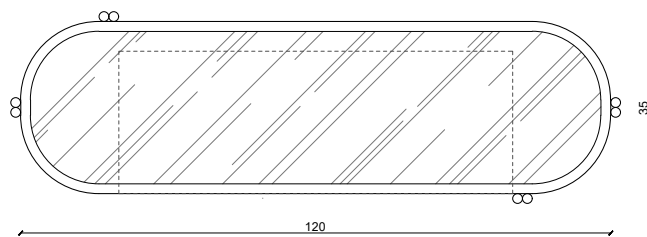
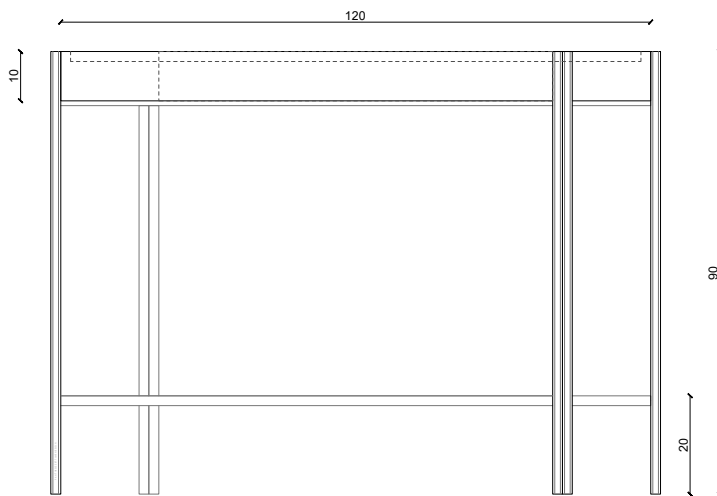

13

**narciso** | vanity vanity desk

Vanity desk con cassetto invisibile e cassetiera adiacente.

*Vanity desk with drawer and adjacent chest of drawers.*

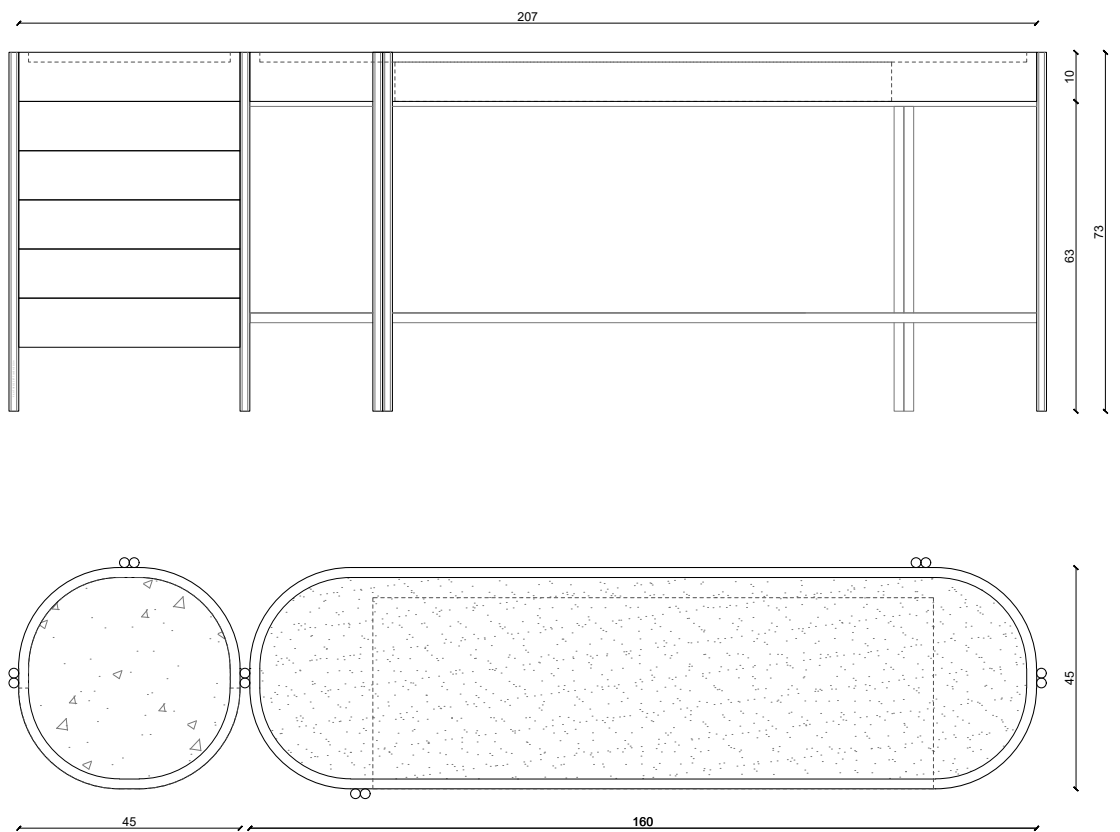

**13**

**narciso** | comodino bedside table

Comodino a due livelli con  
cassetto integrato.

*Two levels sidetable with  
integrated drawer.*

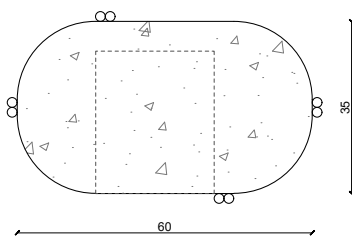
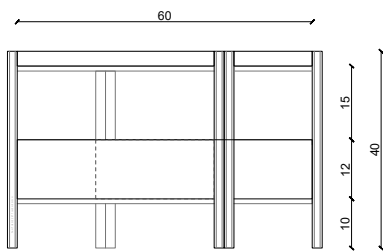

14

**ofiuco** | *tavolini coffee tables*

Tavolino con top in marmo e  
struttura in ottone bronzato.

*Coffee table with marble top and  
bronzed brass structure.*

piccolo *minimum*

medio *medium*

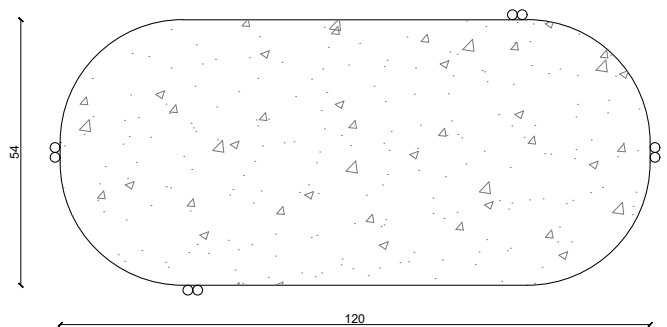
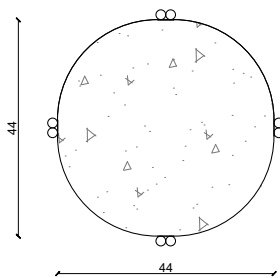
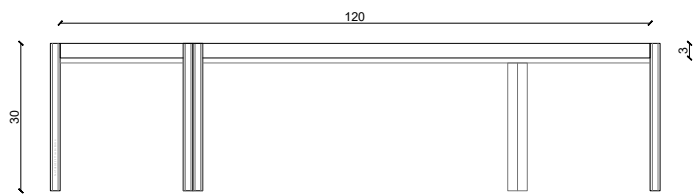
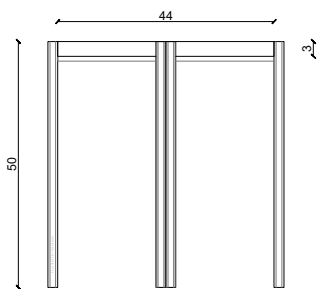

14

**ofiuco** | *tavolini coffee tables*

Tavolino con top in marmo e  
struttura in ottone bronzato.

*Coffee table with marble top and  
bronzed brass structure.*

grande *large*

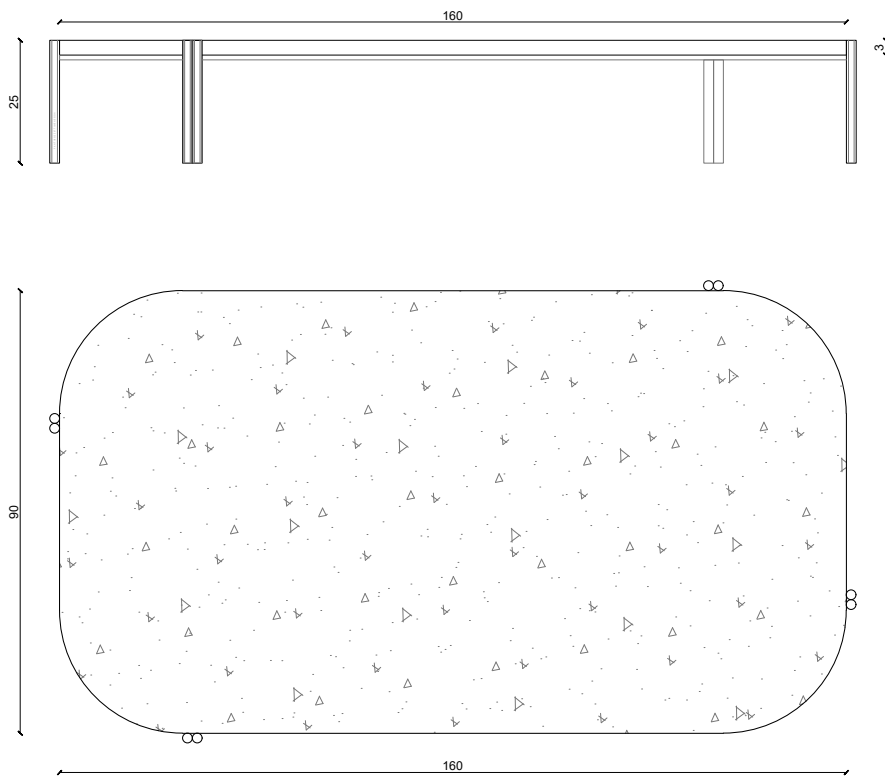

14

**ofiuco** | panca *bench*

Panca con top in marmo, struttura in ottone bronzato e cuscino in pelle.

*Bench with marble top, bronzed brass structure and leather cushion.*

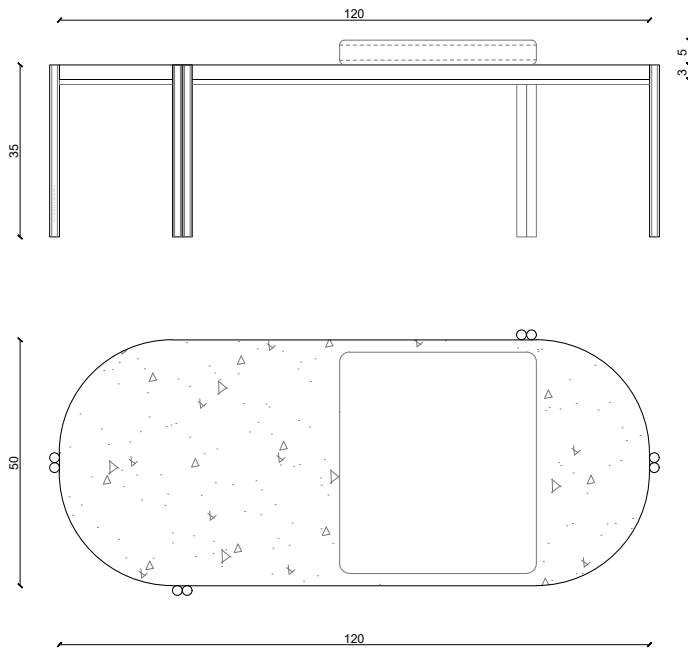

15

**venere** | consolle console

Consolle in ottone spazzolato con  
ripiano in marmo.

*Solid brushed brass console with  
marble top.*

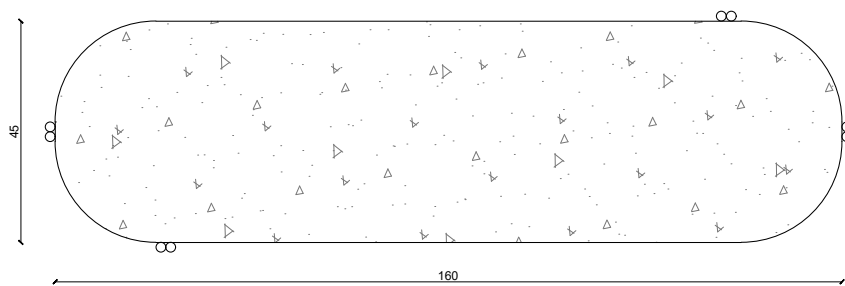

15

**venere** | *madia sideboard*

Madia in ottone spazzolato  
con ripiano in marmo e vano  
contenitore in legno cannettato.

*Solid brushed brass madia with  
marble top and ribbed wood  
storage unit.*

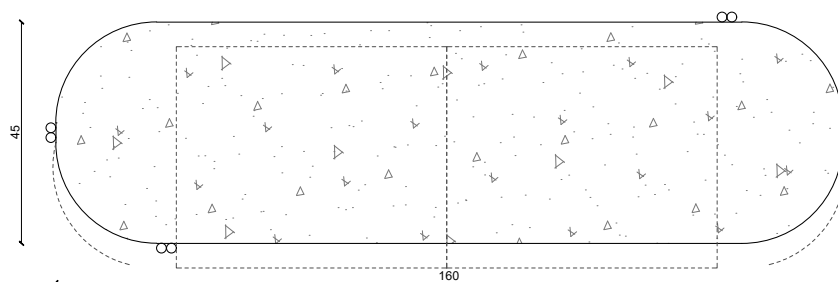
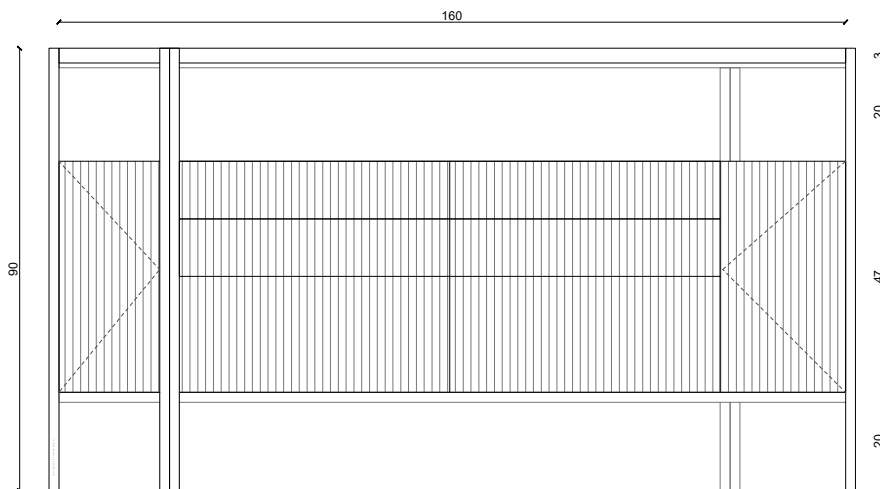

16

**vesta** | cabina armadio *closet*

Cabina armadio modulare con ripiani in marmo/legno/laccati e struttura in metallo finitura ottone bronzato.

*Modular walk-in closet with marble/wood/lacquered shelves and metal structure finished in bronzed brass.*

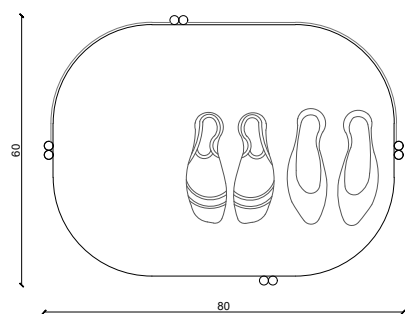
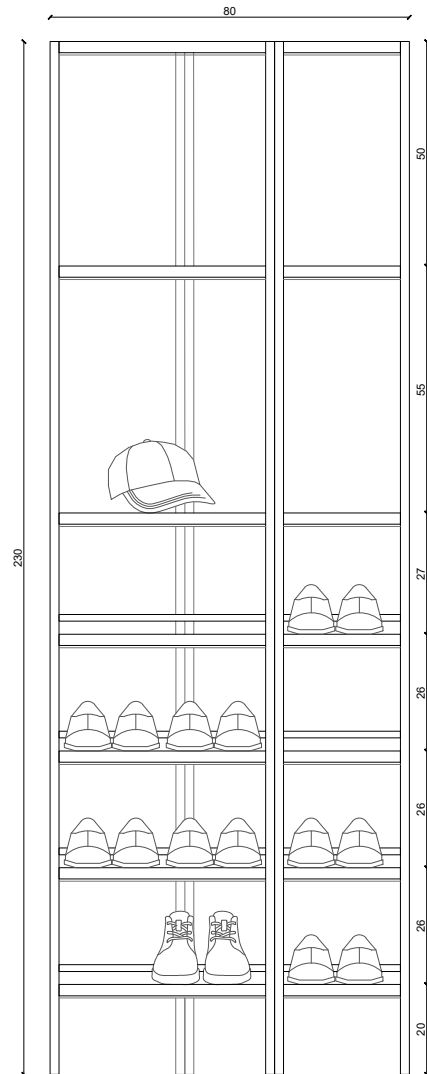

VST\_A

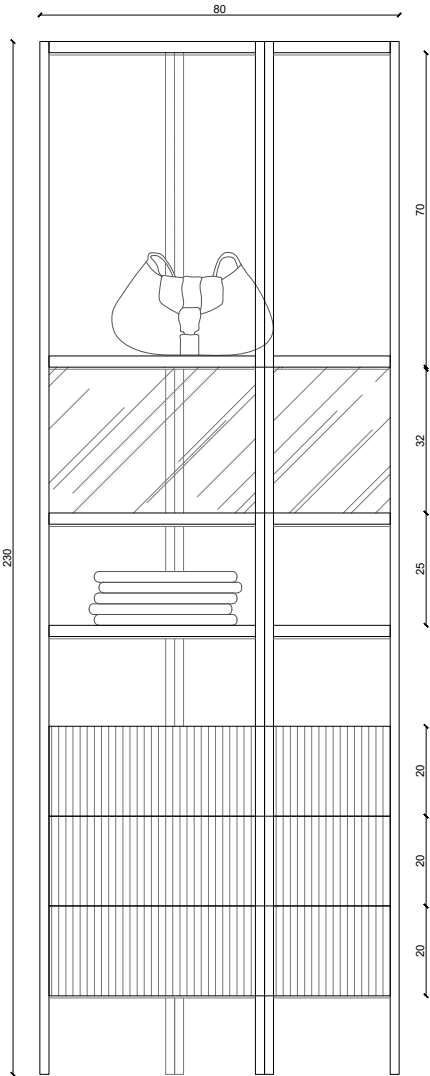

VST\_B

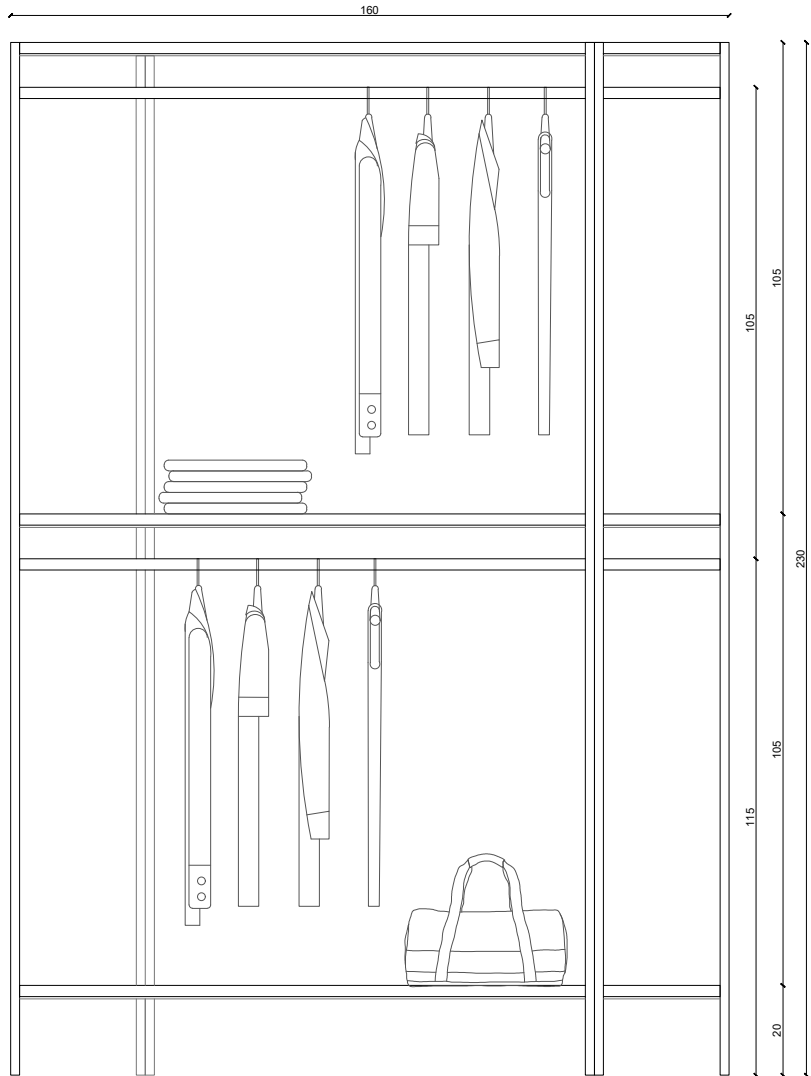

VST\_C

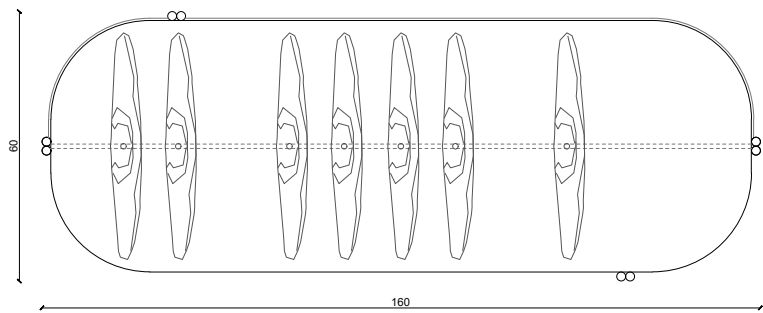
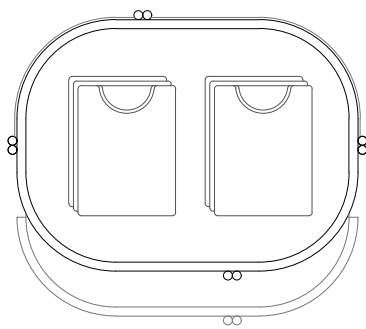

vesta totale  
total vesta

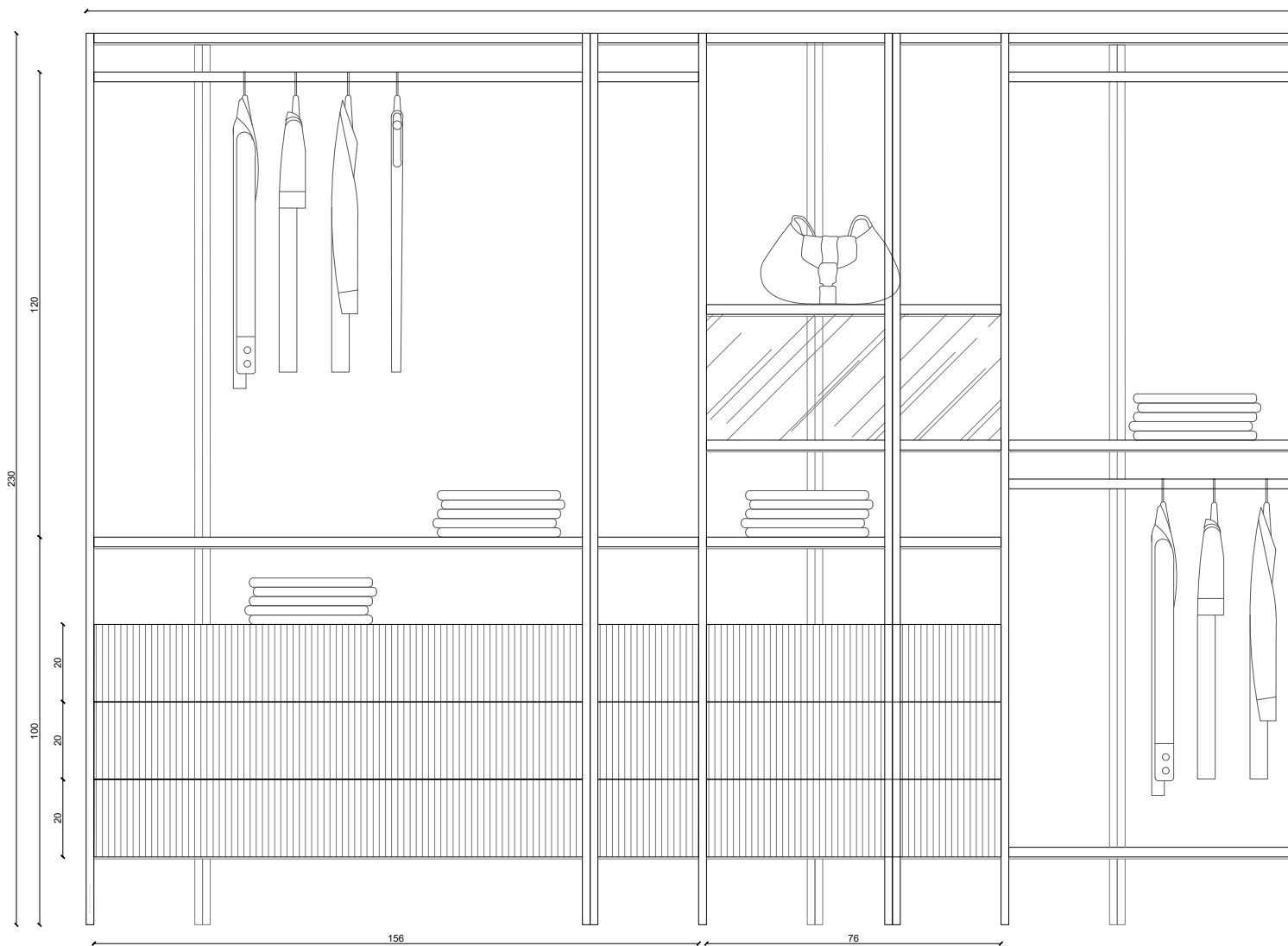

114

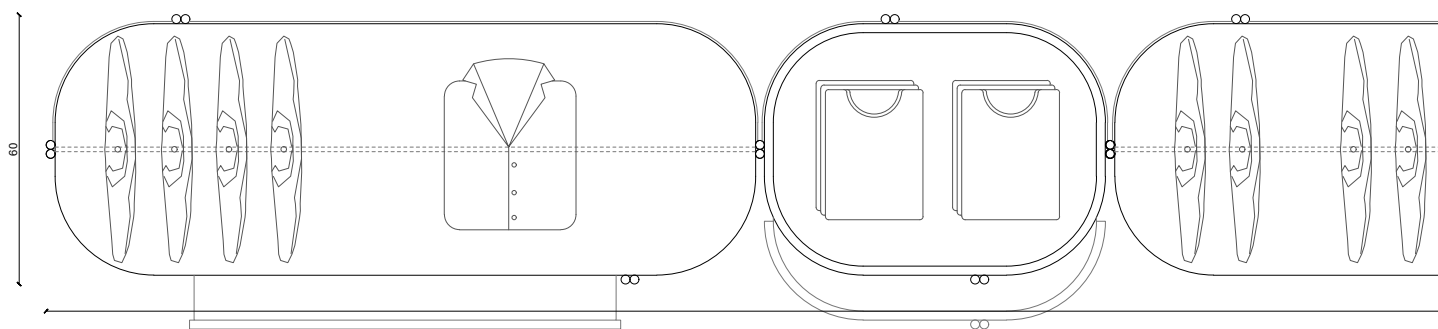

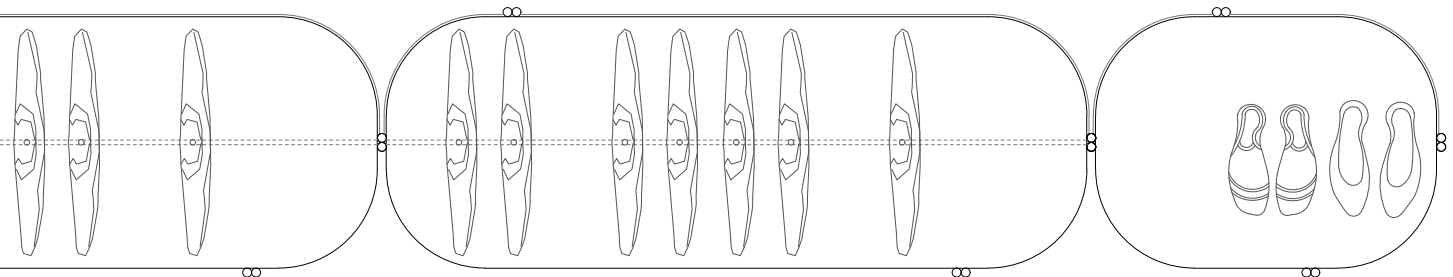
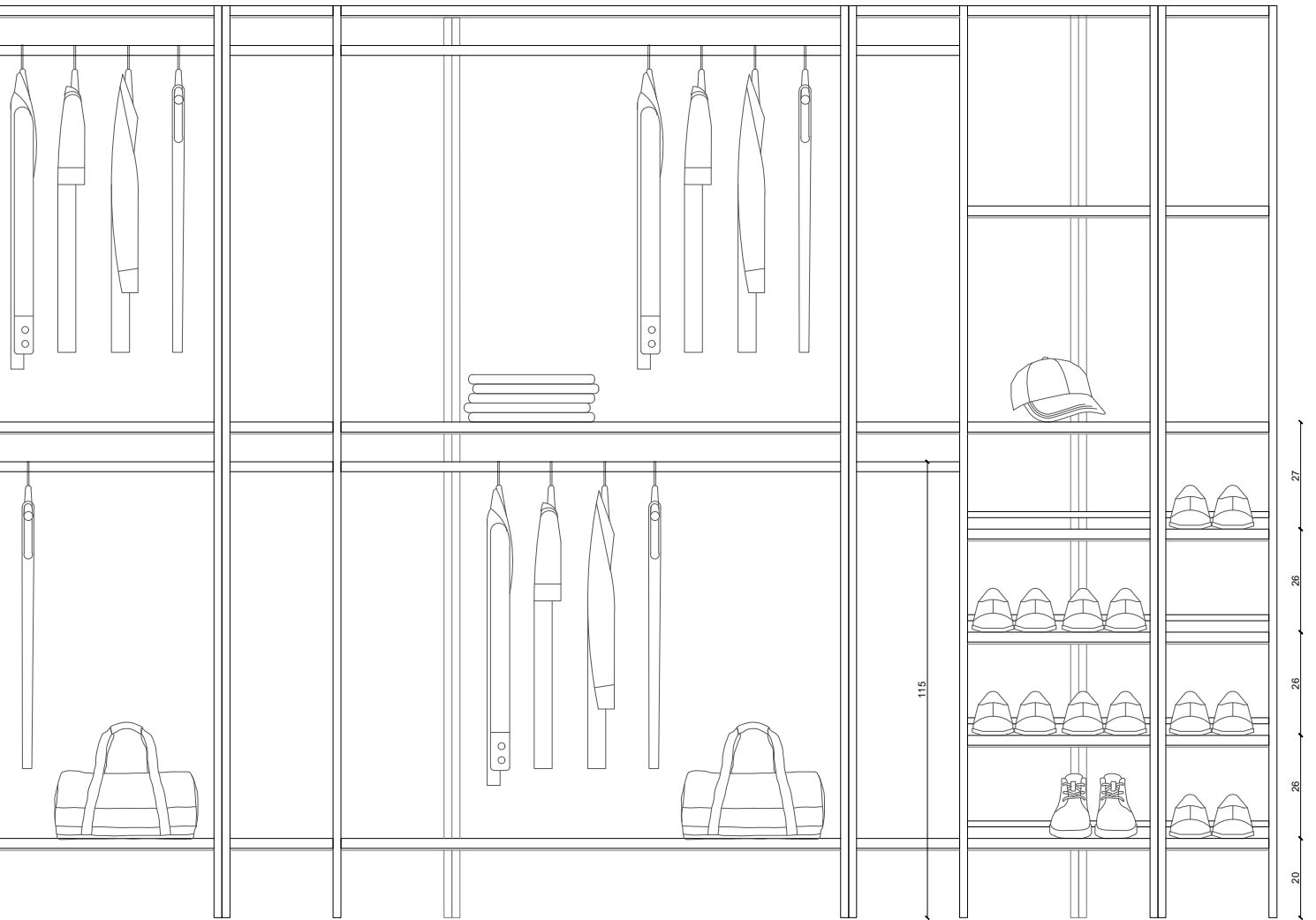

I vasi in marmo *brique* e *slice* sono stati realizzati  
in collaborazione con:

*The marble vases brique and slice have been  
produced in collaboration with:*

**Casone**

[www.casonegroup.com](http://www.casonegroup.com)  
@casone\_group

---

## 100% made in italy

Prodotti interamente realizzati a mano, piccole difformità nella finitura dei materiali sono da ritenersi sinonimo di unicità.

*Products entirely handmade, small differences in the finish of the materials are to be considered synonymous with uniqueness.*

Grazie a:

*Thanks to:*



www.for-living.it  
@forlivingmilano

For Living è un brand italiano, specializzato in contract e forniture di interni.

- "Realizziamo forniture complete di interni in Italia e all'estero lavorando al fianco degli architetti. Progettiamo, produciamo ed installiamo ambienti completi in stile moderno, contemporaneo e classico. Macchine a controllo numerico ed artigianalità si coniugano in una produzione di falegnameria industriale." -

*For Living is an Italian brand, specialized in contract and interior supplies.*

*- "We produce complete interior supplies in Italy and abroad, working alongside architects. We design, produce and install complete environments in a modern, contemporary and classic style. Numerical control machines and craftsmanship are combined in an industrial carpentry production." -*



# FANTIBOZZETTIMENEGON

ARCHITECTURE | INTERIOR | PRODUCT

Via dei Giardini 3  
20121 Milano

[www.fantibozzettimenegon.com](http://www.fantibozzettimenegon.com)

@fantibozzettimenegon

Nella fotografia a sinistra,  
i due fondatori dello studio:  
Fabio Fanti Bozzetti e Martina Menegon.

*In the picture on the left,  
the two founders of the studio:  
Fabio Fanti Bozzetti and Martina Menegon.*



