



US010299981B2

(12) **United States Patent**
Kalinowski

(10) **Patent No.:** **US 10,299,981 B2**

(45) **Date of Patent:** **May 28, 2019**

(54) **MOTORIZED AIR WALKER AND SUSPENSION SYSTEM FOR PARALYZED PERSONS**

(58) **Field of Classification Search**
CPC A61H 3/008; A61H 2201/1261; A61H 2201/1296; A63B 21/1672; A61G 7/002; A61G 7/005; A61G 7/012
See application file for complete search history.

(71) Applicant: **Eugene Kalinowski**, Westhampton, NY (US)

(56) **References Cited**

(72) Inventor: **Eugene Kalinowski**, Westhampton, NY (US)

U.S. PATENT DOCUMENTS

(*) Notice: Subject to any disclaimer, the term of this patent is extended or adjusted under 35 U.S.C. 154(b) by 150 days.

3,450,132 A * 6/1969 Ragon A61G 13/009 601/26
3,823,712 A 7/1974 Morel
(Continued)

(21) Appl. No.: **15/242,988**

FOREIGN PATENT DOCUMENTS

(22) PCT Filed: **Mar. 5, 2015**

WO 2003105744 A3 4/2004
WO 2012008664 A1 1/2012

(86) PCT No.: **PCT/US2015/018852**

(Continued)

§ 371 (c)(1),

(2) Date: **Aug. 22, 2016**

OTHER PUBLICATIONS

(87) PCT Pub. No.: **WO2015/134693**

PCT Written Opinion corresponding to counterpart Int'l Appln. No. PCT/US2015/018852 dated Jun. 8, 2015.

PCT Pub. Date: **Sep. 11, 2015**

Primary Examiner — Nyca T Nguyen

(65) **Prior Publication Data**

(74) *Attorney, Agent, or Firm* — Carter, DeLuca & Farrell LLP

US 2017/0246069 A1 Aug. 31, 2017

(57) **ABSTRACT**

Related U.S. Application Data

A system for patient rehabilitation includes a first movable frame including an articulating bed, wherein the bed is configured to be selectively articulated to an inclined position, a suspension system, wherein the suspension system is disposed within the articulating bed and is selectively adjustable to accommodate varying patient height, a harness, wherein the harness is selectively engageable with the suspension system, wherein the harness is selectively adjustable to accommodate varying patient sizes, a second movable frame including a walker, wherein the walker includes a pair of legs and a motor, wherein approximation of the two movable frames permits the patient to easily utilize the walker from the bed.

(63) Continuation of application No. 14/639,247, filed on Mar. 5, 2015.

(Continued)

(51) **Int. Cl.**

A61H 3/00 (2006.01)

A61G 7/10 (2006.01)

(Continued)

(52) **U.S. Cl.**

CPC **A61H 3/008** (2013.01); **A61G 7/018** (2013.01); **A61G 7/1046** (2013.01);

(Continued)

10 Claims, 31 Drawing Sheets

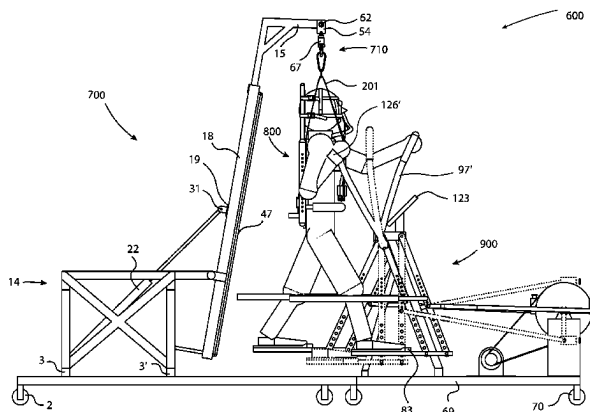

Related U.S. Application Data						
		5,406,658	A *	4/1995	Olkkonen	A61G 7/005 5/83.1
(60)	Provisional application No. 61/967,016, filed on Mar. 7, 2014.	5,459,891	A	10/1995	Reeve et al.	
		6,162,151	A	12/2000	Tani et al.	
		6,666,798	B2	12/2003	Borsheim	
(51)	Int. Cl.	6,685,658	B1 *	2/2004	Dietz	A61H 1/0229 128/845
	<i>A61H 1/02</i> (2006.01)	6,821,233	B1	11/2004	Colombo et al.	
	<i>A63B 21/00</i> (2006.01)	7,011,605	B2	3/2006	Shields	
	<i>A63B 22/00</i> (2006.01)	7,137,959	B2	11/2006	Phillips	
	<i>A63B 22/06</i> (2006.01)	7,163,492	B1 *	1/2007	Sotiriades	A61H 1/0237 482/51
	<i>A63B 23/035</i> (2006.01)	7,699,140	B2	4/2010	Beggrow et al.	
	<i>A61G 7/018</i> (2006.01)	7,793,950	B2	9/2010	Van Eeden	
	<i>A63B 21/22</i> (2006.01)	7,802,331	B2 *	9/2010	Brown	A47C 19/045 5/610
(52)	U.S. Cl.	7,846,080	B2 *	12/2010	Boren	A61H 1/0218 482/130
	CPC	8,613,691	B2	12/2013	Bosecker et al.	
	<i>A61G 7/1051</i> (2013.01); <i>A61H 1/0262</i> (2013.01); <i>A61H 1/0274</i> (2013.01); <i>A63B 21/225</i> (2013.01); <i>A63B 21/4007</i> (2015.10); <i>A63B 21/4034</i> (2015.10); <i>A63B 21/4035</i> (2015.10); <i>A63B 22/001</i> (2013.01); <i>A63B 22/0023</i> (2013.01); <i>A63B 22/0664</i> (2013.01); <i>A63B 23/03575</i> (2013.01); <i>A61H 1/0237</i> (2013.01); <i>A61H 2001/0211</i> (2013.01); <i>A61H 2003/007</i> (2013.01); <i>A61H 2201/0142</i> (2013.01); <i>A61H 2201/0157</i> (2013.01); <i>A61H 2201/10</i> (2013.01); <i>A61H 2201/107</i> (2013.01); <i>A61H 2201/1215</i> (2013.01); <i>A61H 2201/1409</i> (2013.01); <i>A61H 2201/1481</i> (2013.01); <i>A61H 2201/1607</i> (2013.01); <i>A61H 2201/1614</i> (2013.01); <i>A61H 2201/1621</i> (2013.01); <i>A61H 2201/1638</i> (2013.01); <i>A61H 2201/1642</i> (2013.01); <i>A61H 2201/1652</i> (2013.01); <i>A61H 2201/50</i> (2013.01); <i>A61H 2201/5046</i> (2013.01); <i>A61H 2201/5048</i> (2013.01); <i>A61H 2201/5064</i> (2013.01); <i>A61H 2203/0406</i> (2013.01); <i>A63B 2022/0676</i> (2013.01)	9,248,071	B1 *	2/2016	Benda	A63B 69/0057
		9,421,144	B2	8/2016	Kalinowski	
		9,616,282	B2 *	4/2017	Tholkes	A63B 22/0664
		2002/0011714	A1	1/2002	Kurashige	
		2004/0157708	A1 *	8/2004	Matthews	A63B 22/0007 482/57
		2006/0128537	A1 *	6/2006	Philips	A61H 1/0237 482/95
		2006/0206167	A1	9/2006	Flaherty et al.	
		2007/0016116	A1	1/2007	Reinkensmeyer et al.	
		2007/0037667	A1	2/2007	Gordon	
		2008/0113853	A1 *	5/2008	Jang	A61H 1/0222 482/142
		2009/0036009	A1	2/2009	Carl	
		2010/0042022	A1 *	2/2010	Kim	A61H 1/0214 601/24
		2011/0083266	A1	4/2011	Herron	
		2011/0143898	A1 *	6/2011	Trees	A61G 7/005 482/142
		2011/0166487	A1	7/2011	Fullenkamp	
		2011/0166488	A1	7/2011	Miyake	
		2012/0090089	A1	4/2012	Stryker et al.	
		2012/0209152	A1	8/2012	Cordo	
		2013/0137553	A1	5/2013	Kim et al.	
		2013/0150980	A1	6/2013	Swift et al.	
		2013/0211295	A1	8/2013	Johnson et al.	
		2015/0141209	A1	5/2015	Chen et al.	
		2015/0290072	A1 *	10/2015	Singhal	A61F 5/04 601/35
(56)	References Cited					
	U.S. PATENT DOCUMENTS					
	3,872,945 A	3/1975	Hickman et al.			
	4,422,452 A *	12/1983	Burton	A61H 1/0218 602/36		
	4,639,955 A *	2/1987	Carminati	A61G 7/1015 414/921		
	4,986,261 A	1/1991	Iams et al.			
	5,054,476 A	10/1991	Petrofsky et al.			
	5,308,359 A *	5/1994	Lossing	A61H 1/0222 5/612		
					FOREIGN PATENT DOCUMENTS	
				WO	2014078667 A1	5/2014
				WO	2015134693 A1	9/2015

* cited by examiner

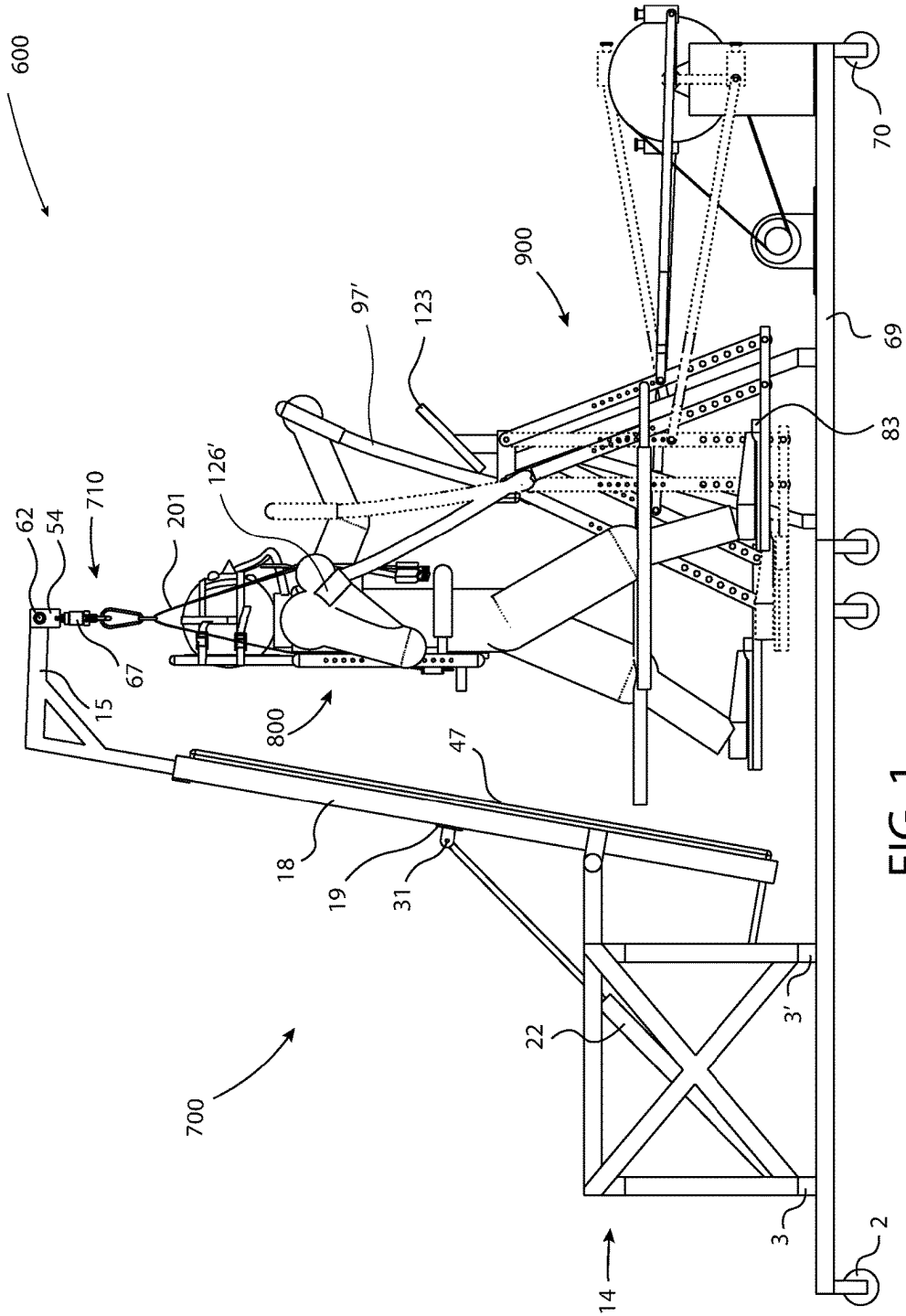

FIG. 1

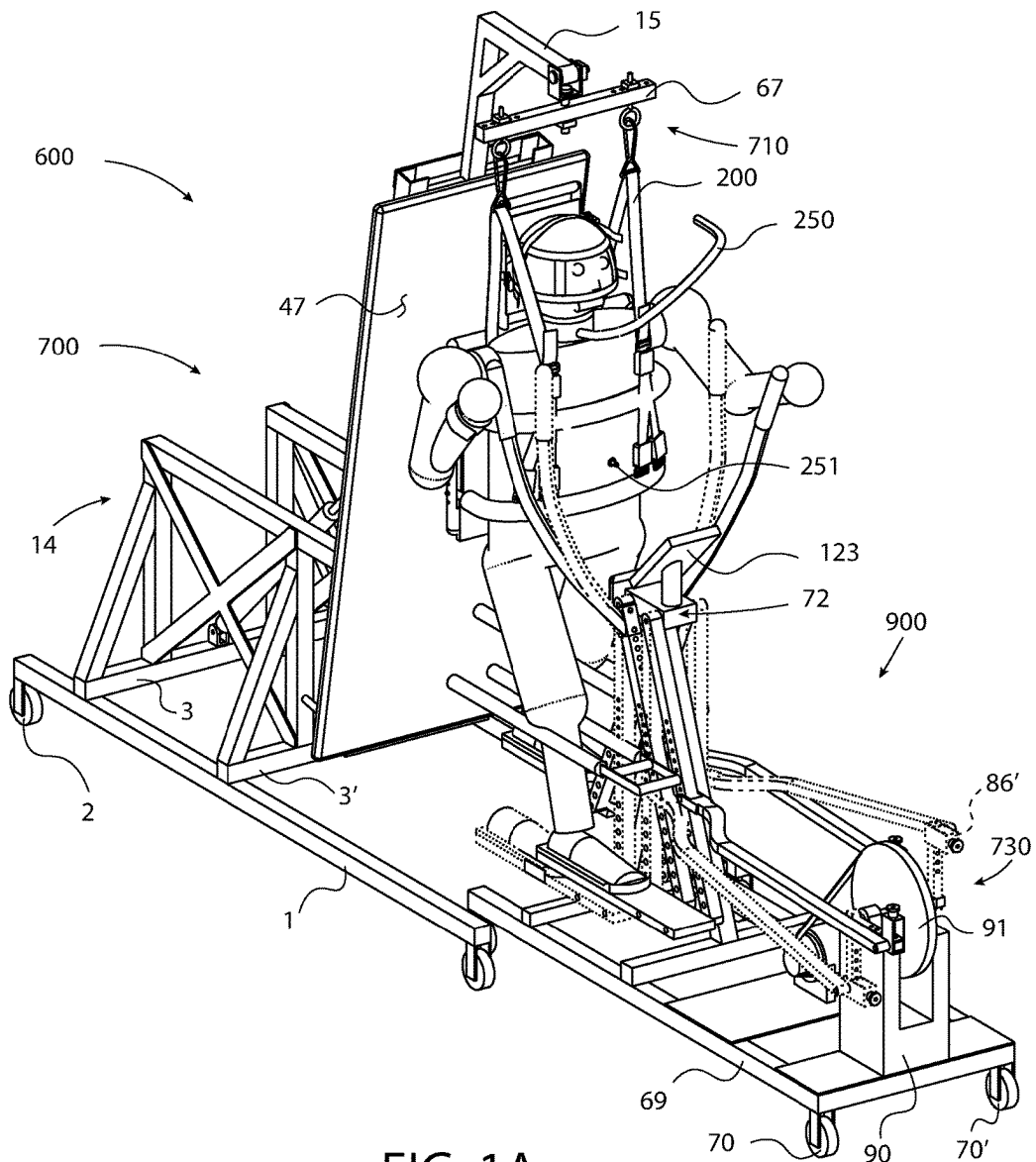

FIG. 1A

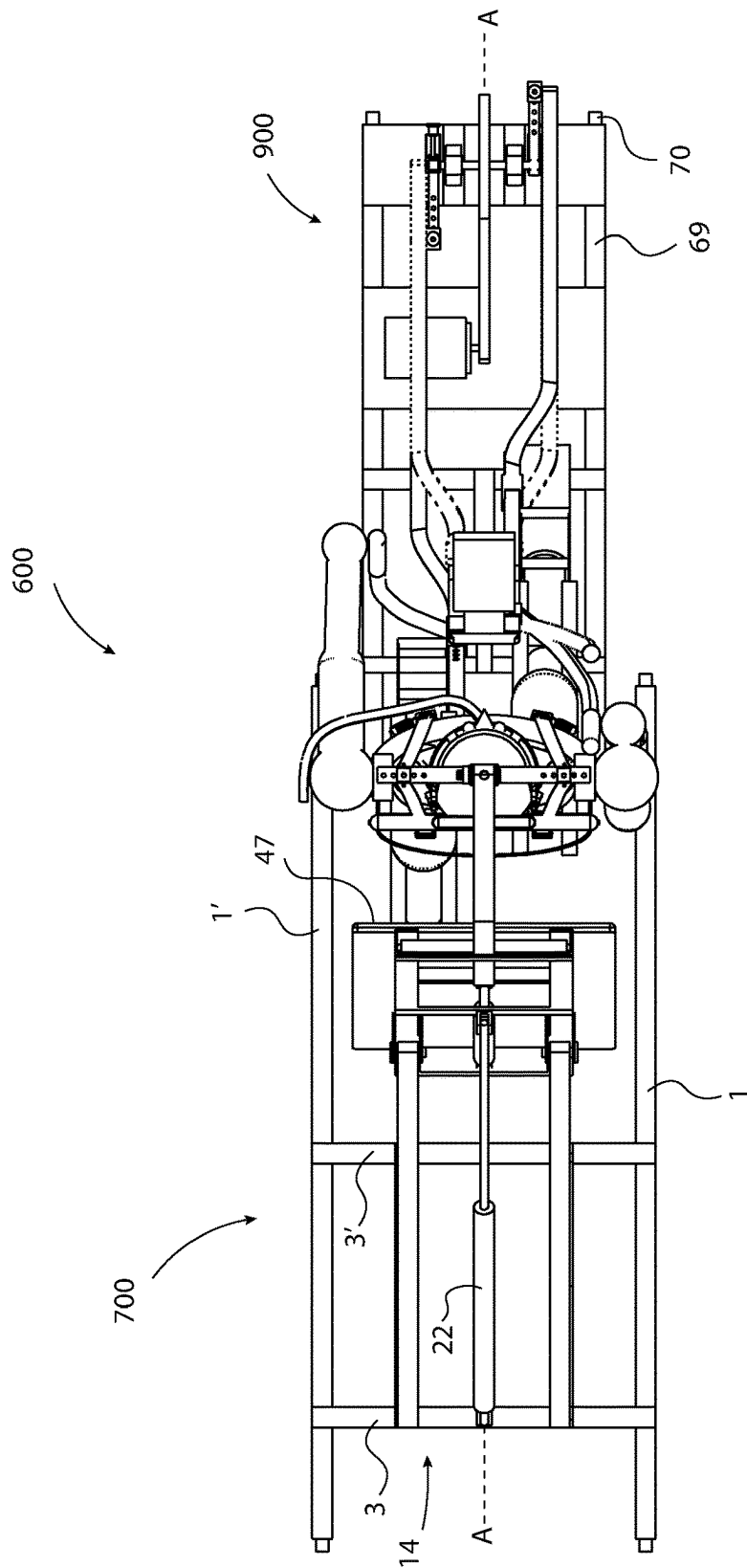

FIG. 2

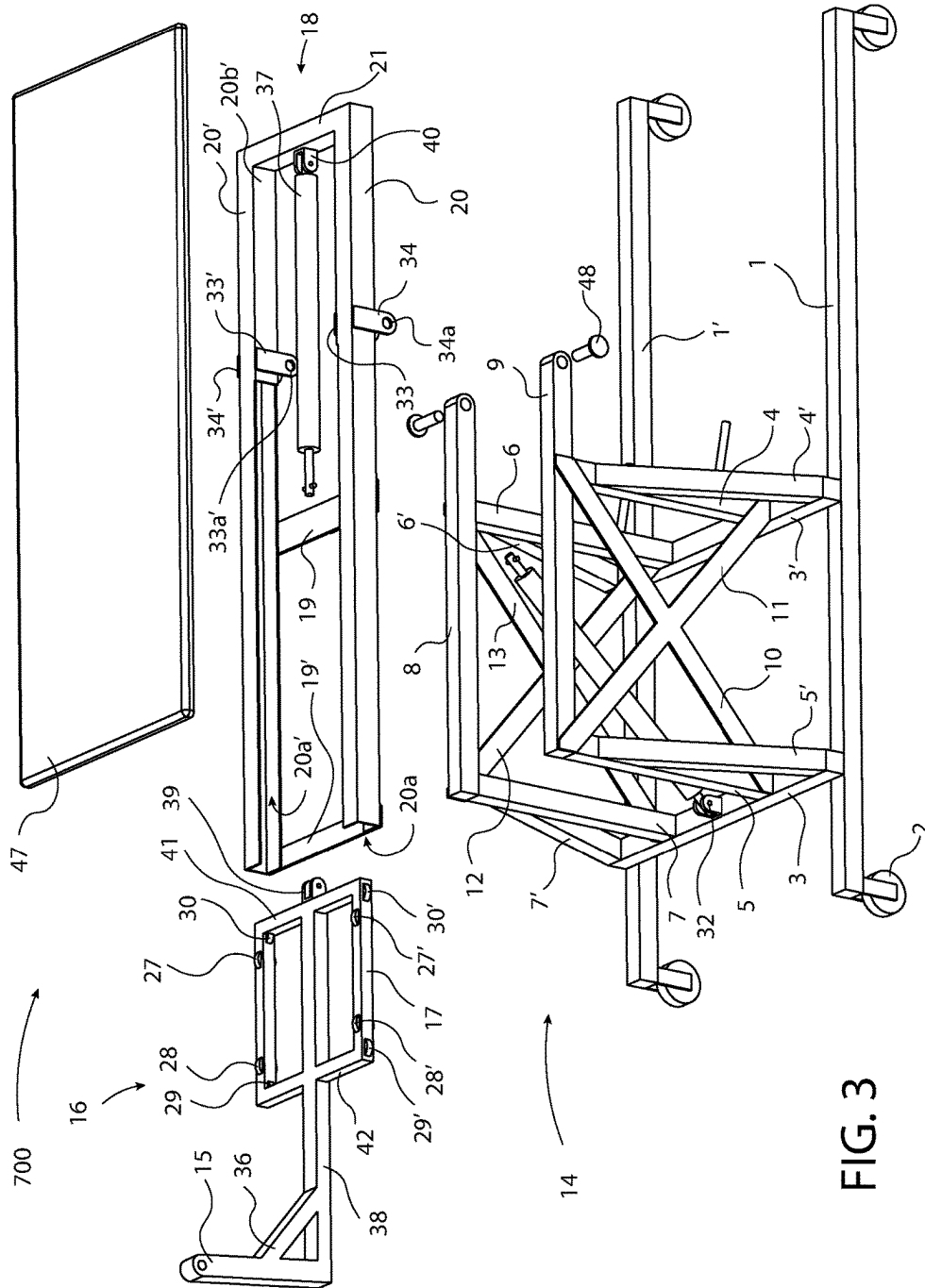
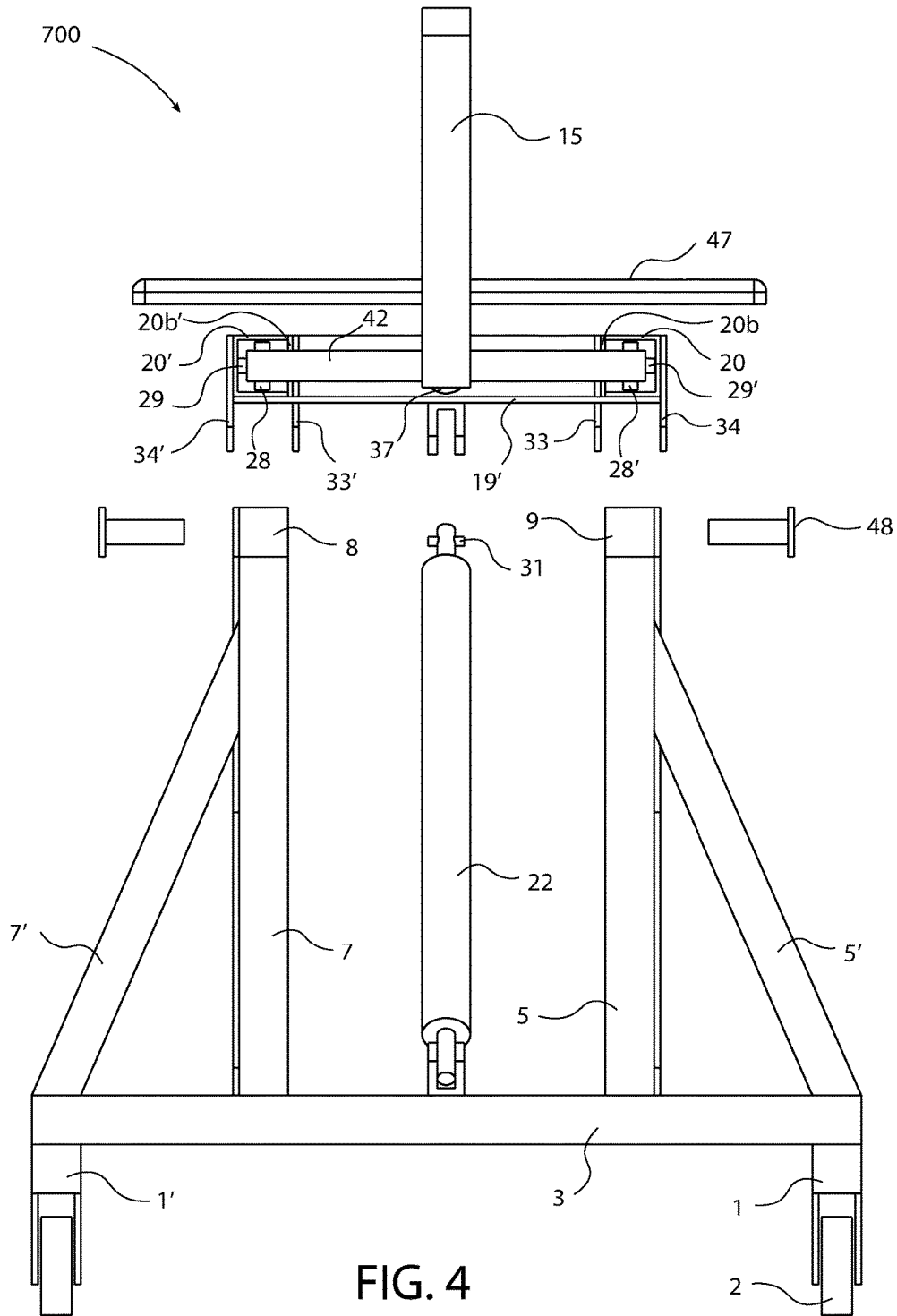

FIG. 3



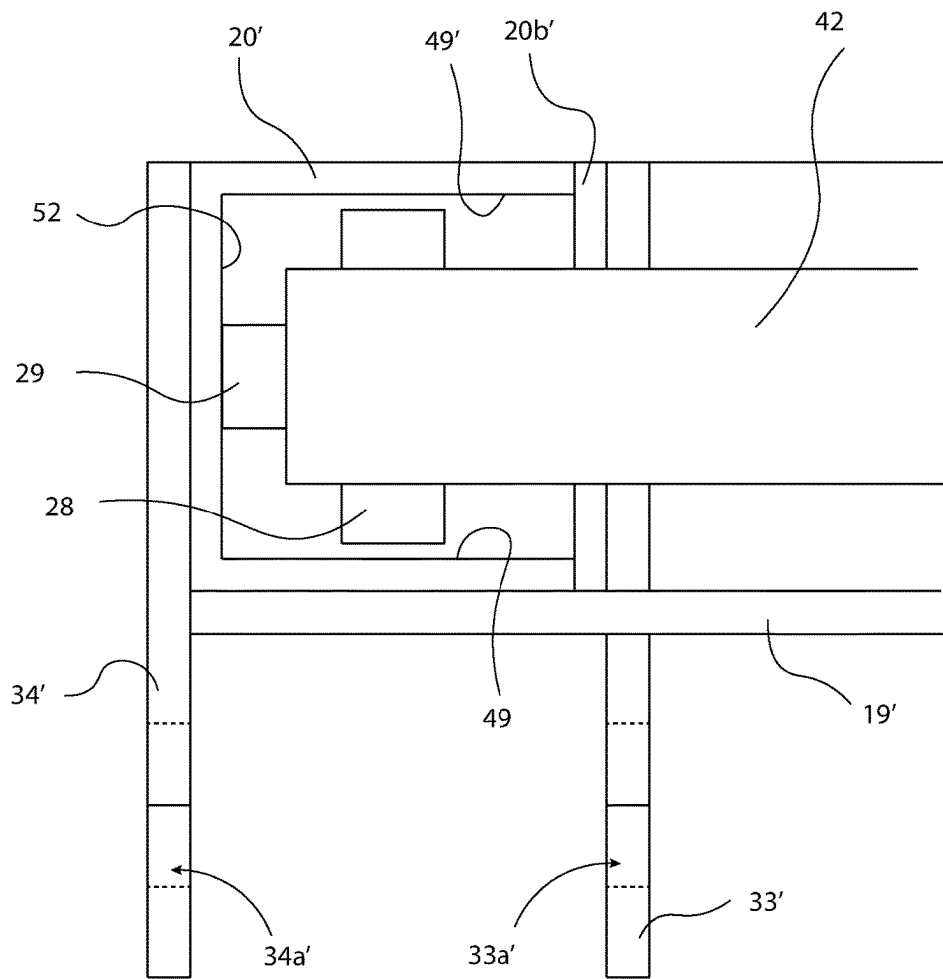

FIG. 4A

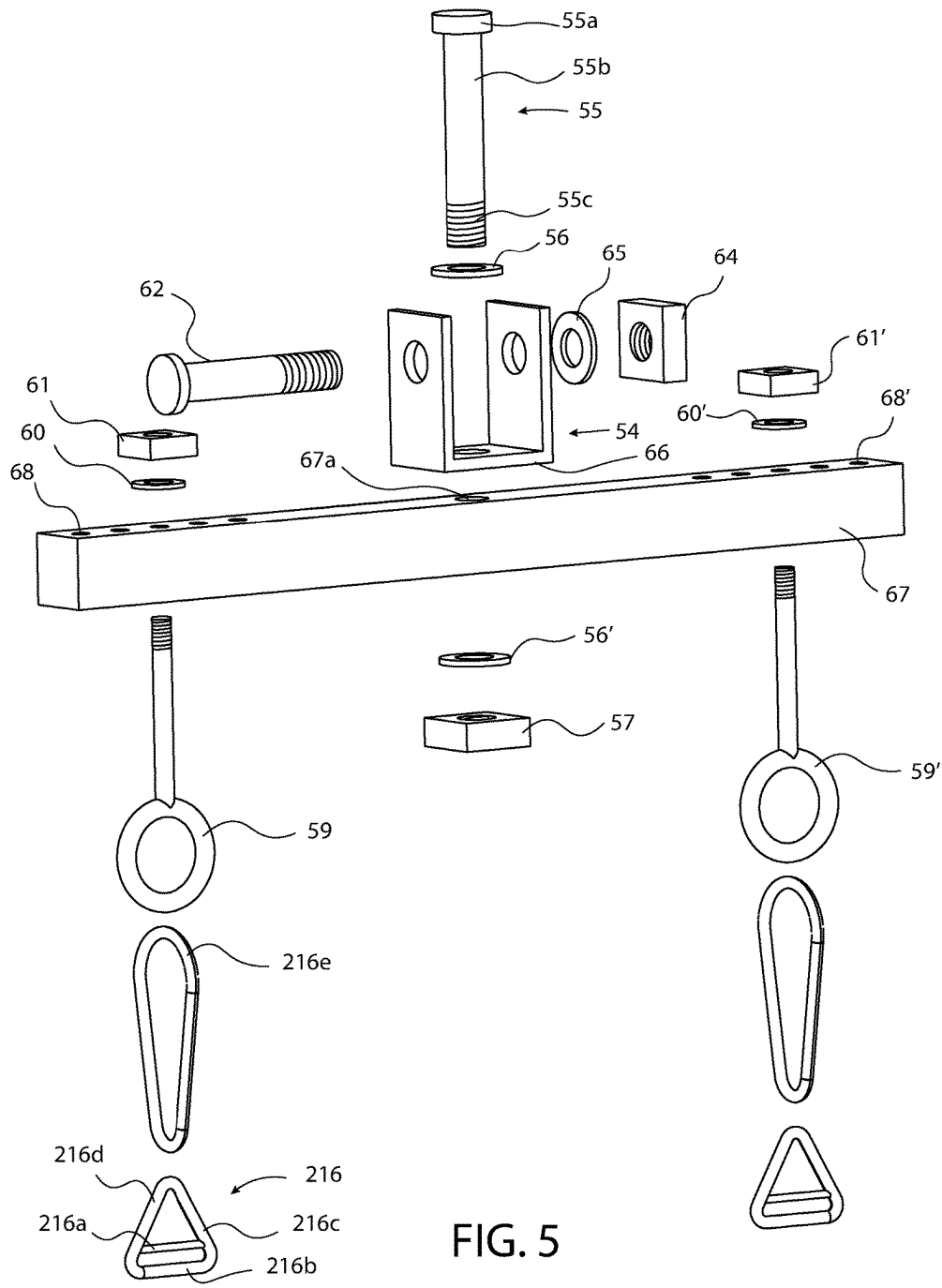
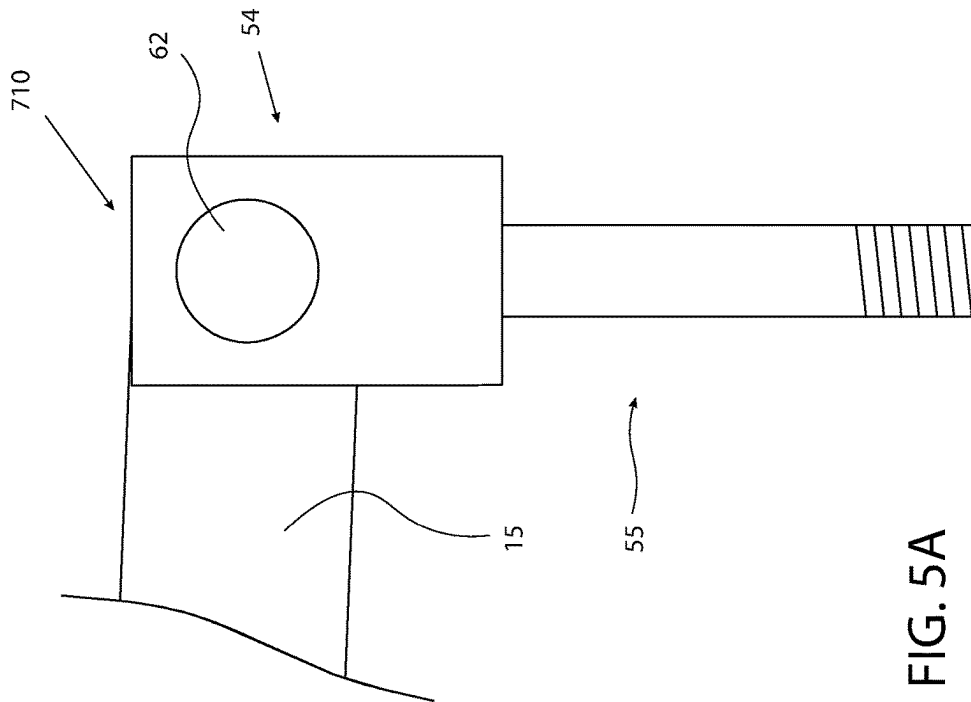
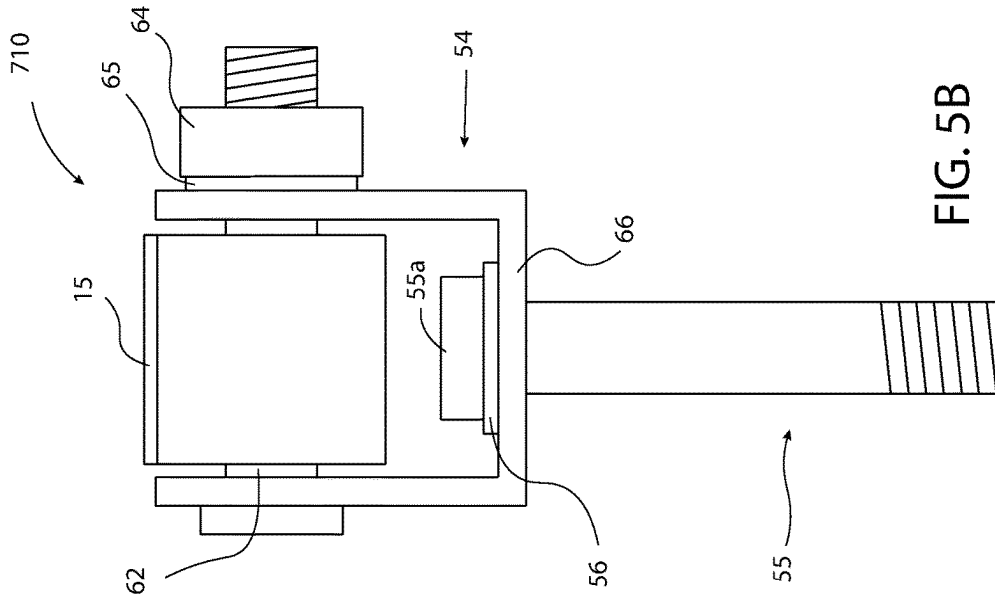
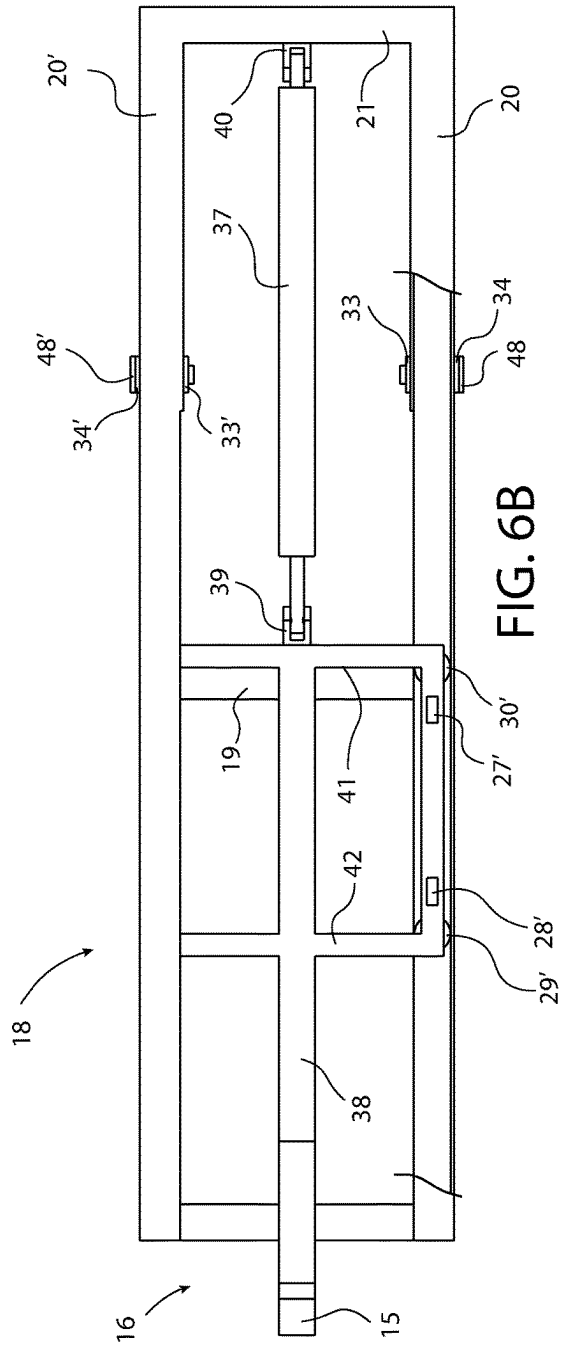
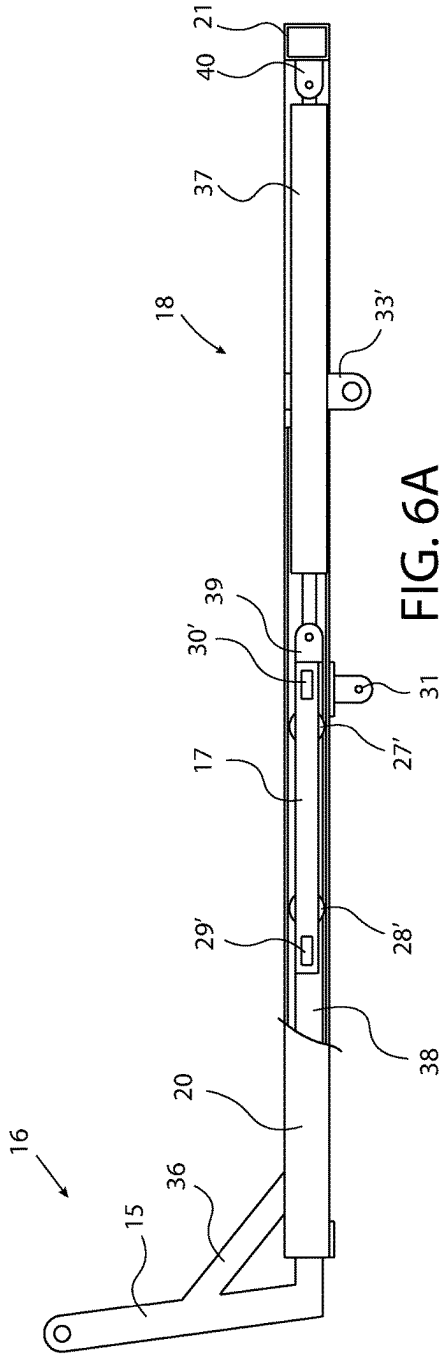

FIG. 5





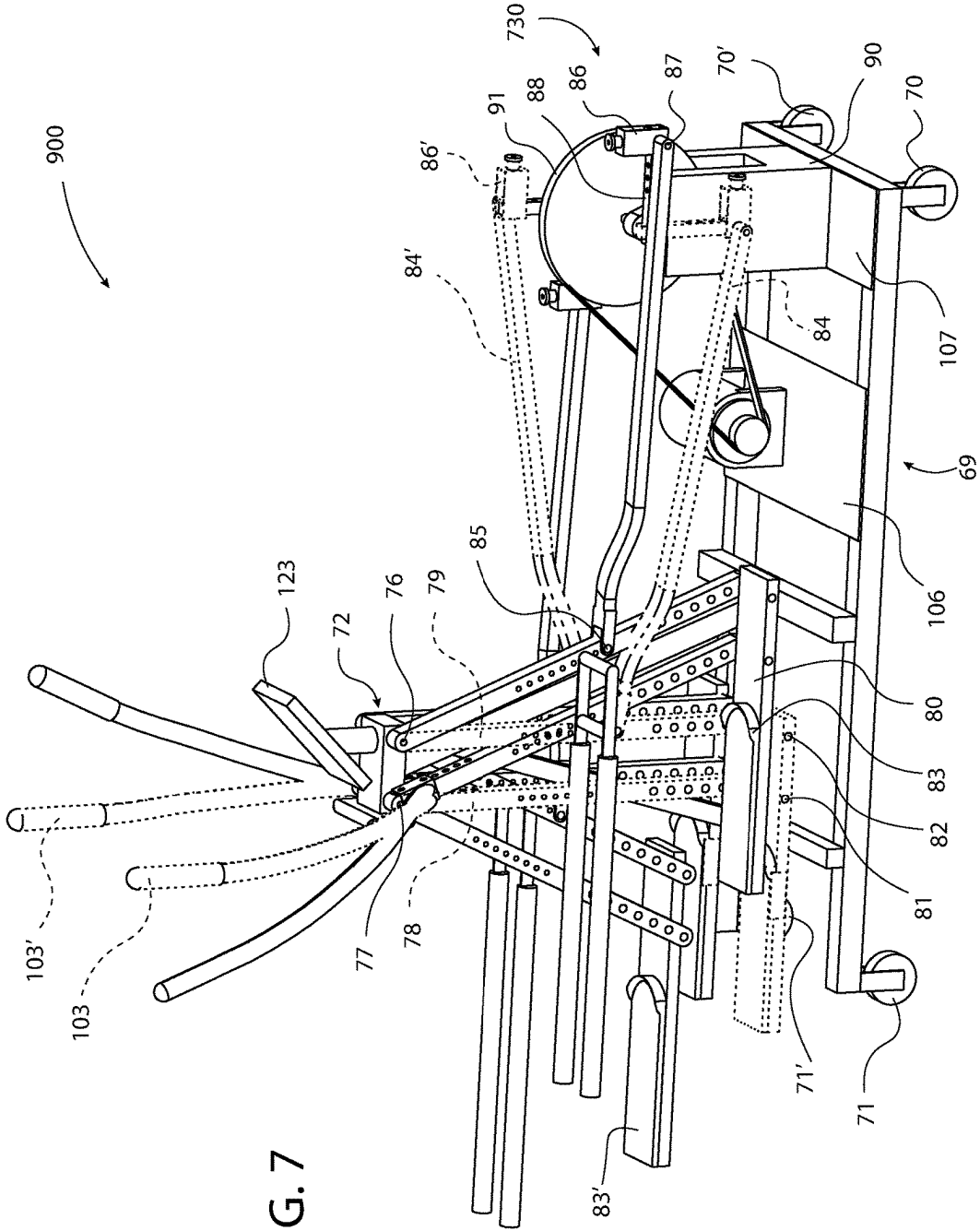

FIG. 7

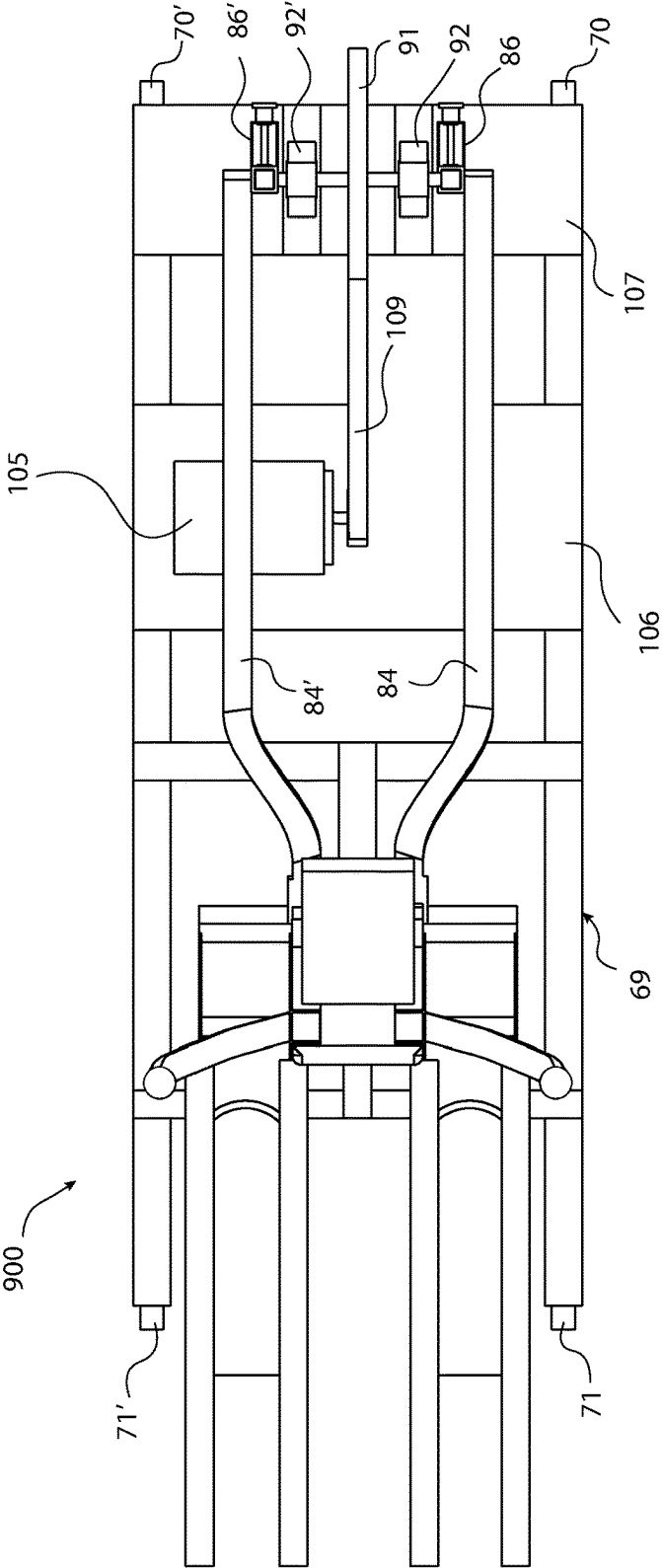

FIG. 8

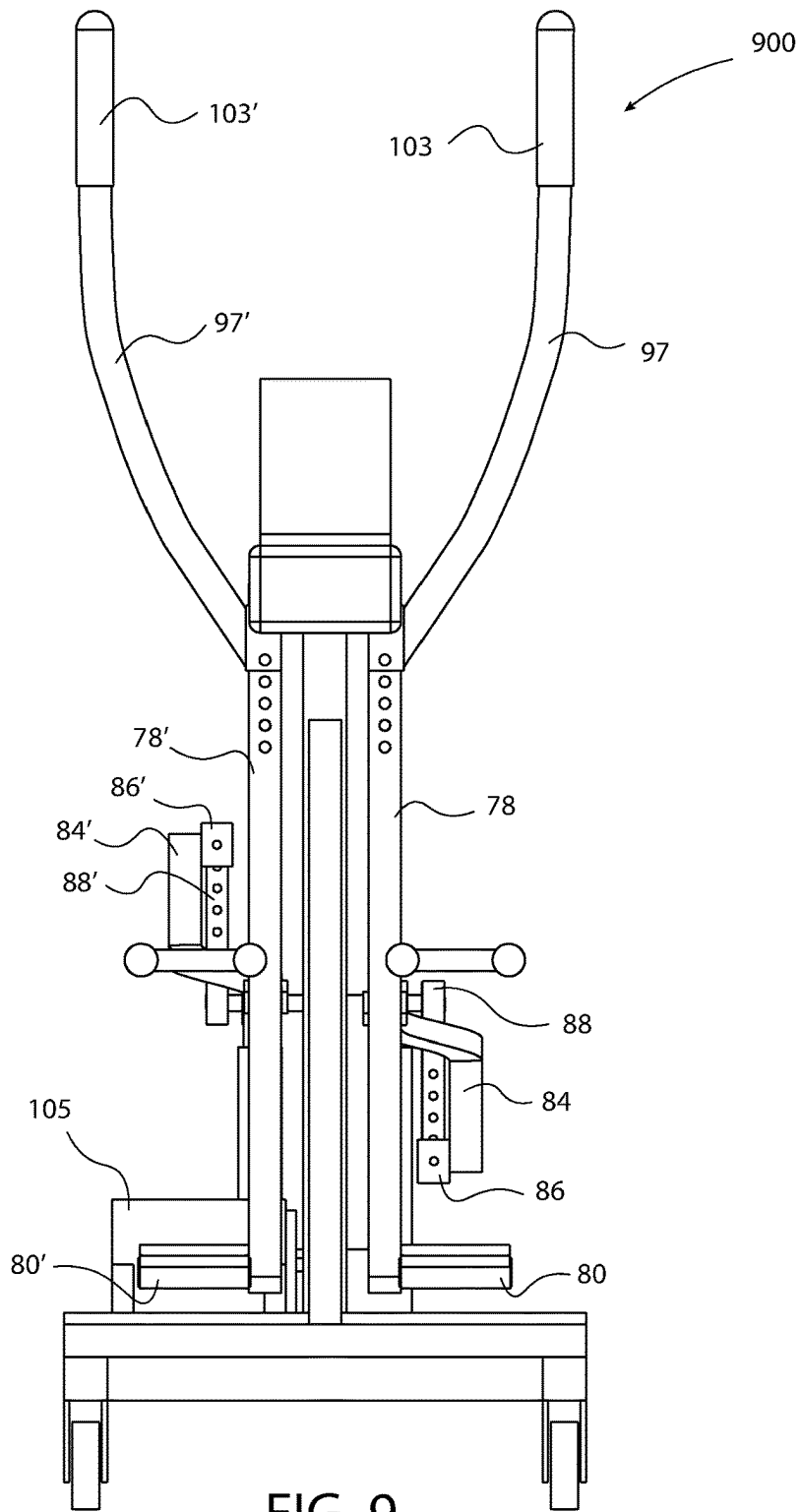

FIG. 9

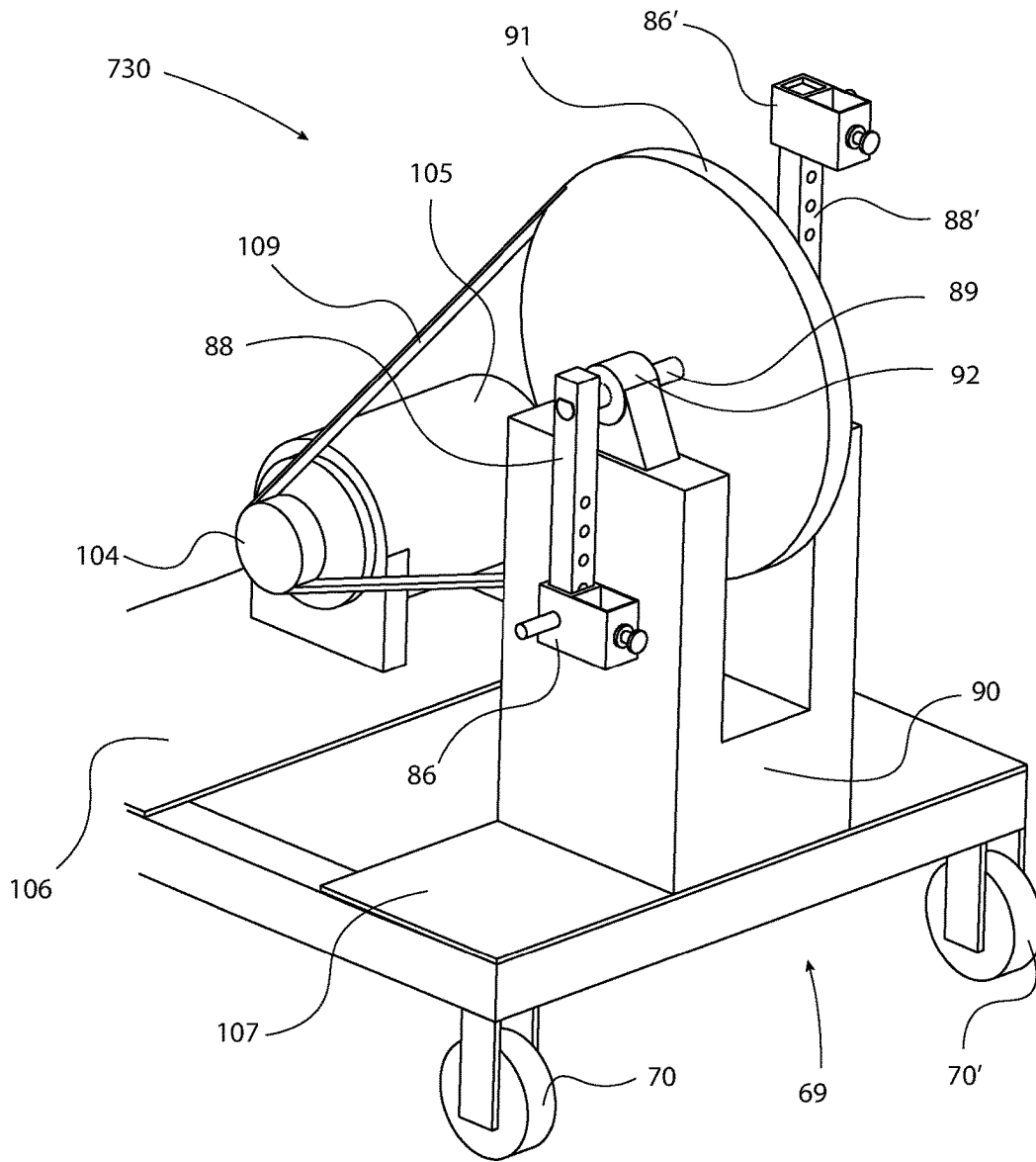
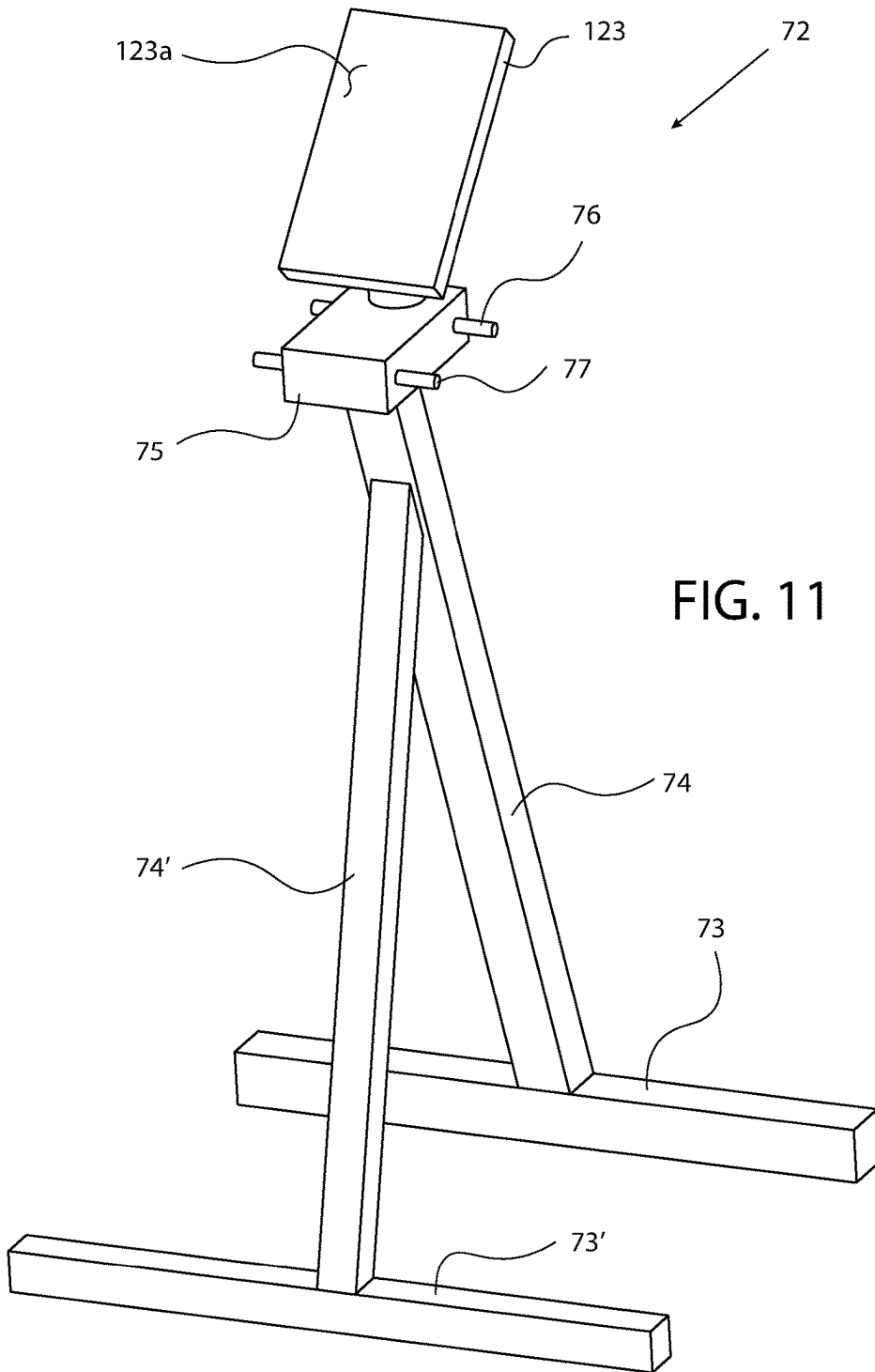

FIG.10



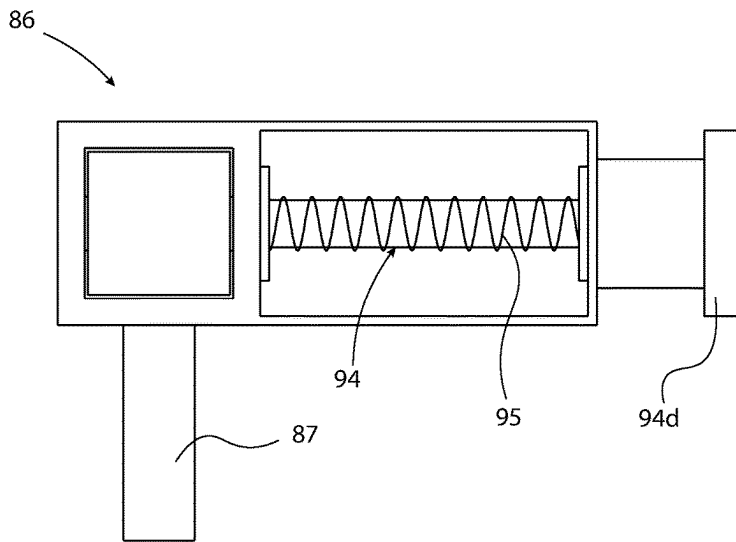

FIG. 12A

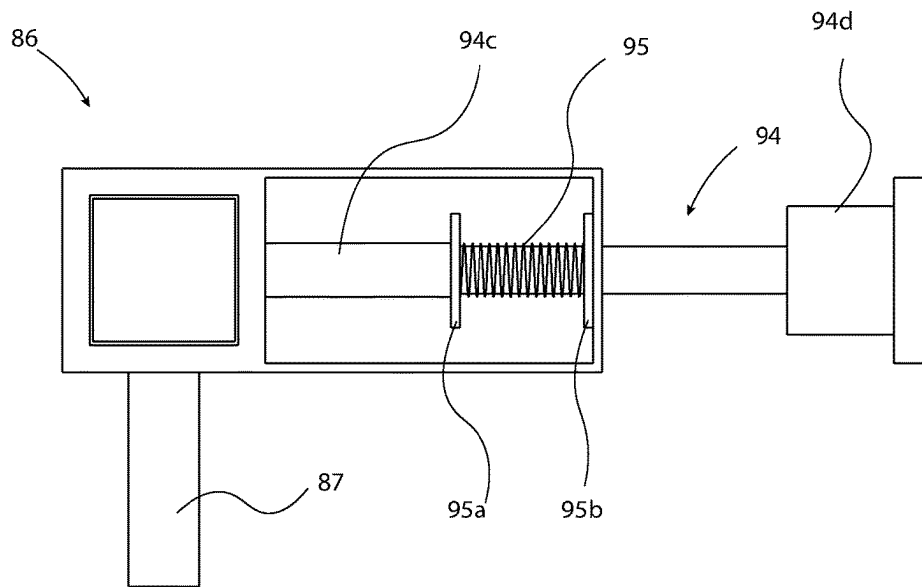
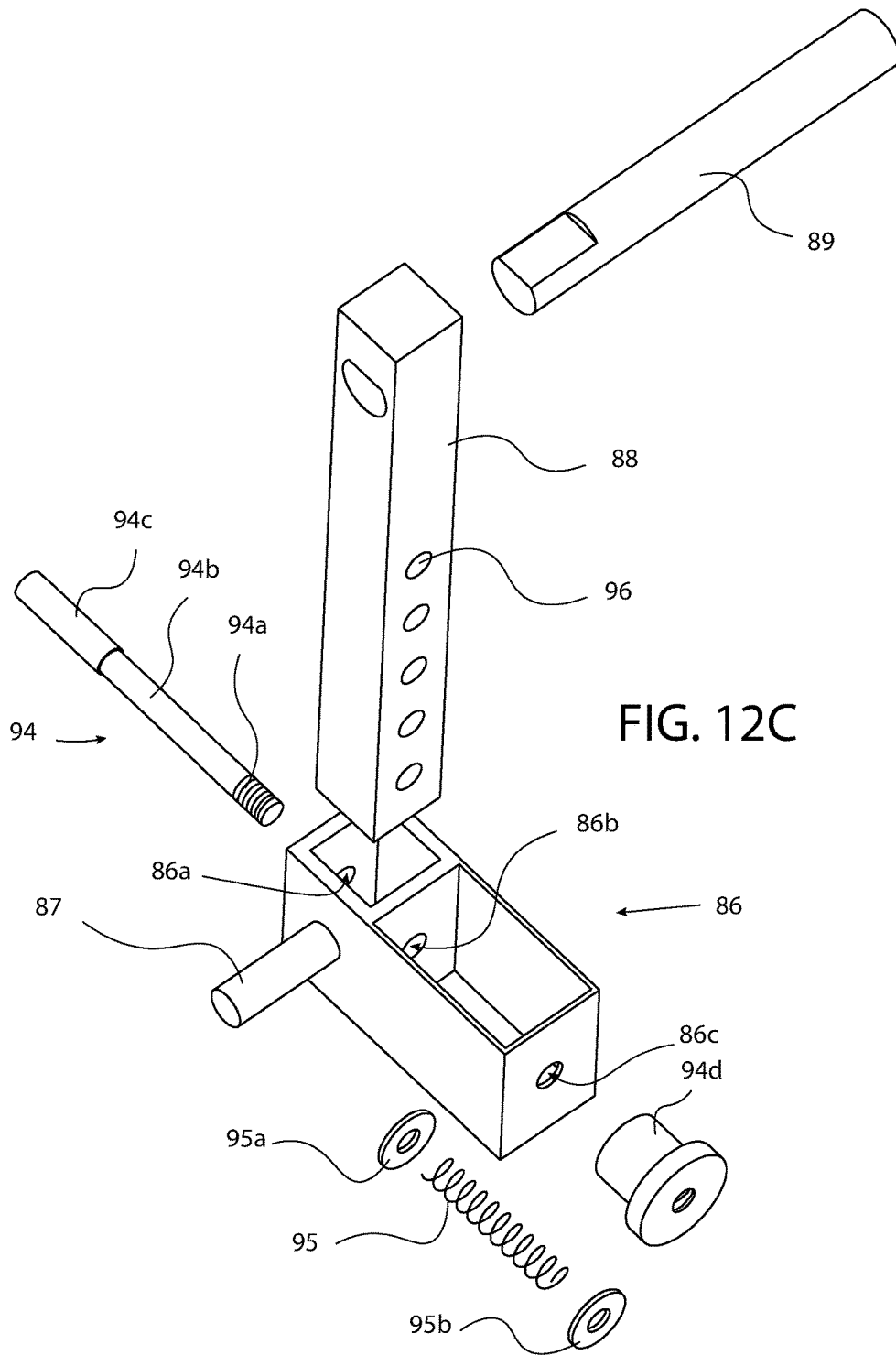

FIG. 12B



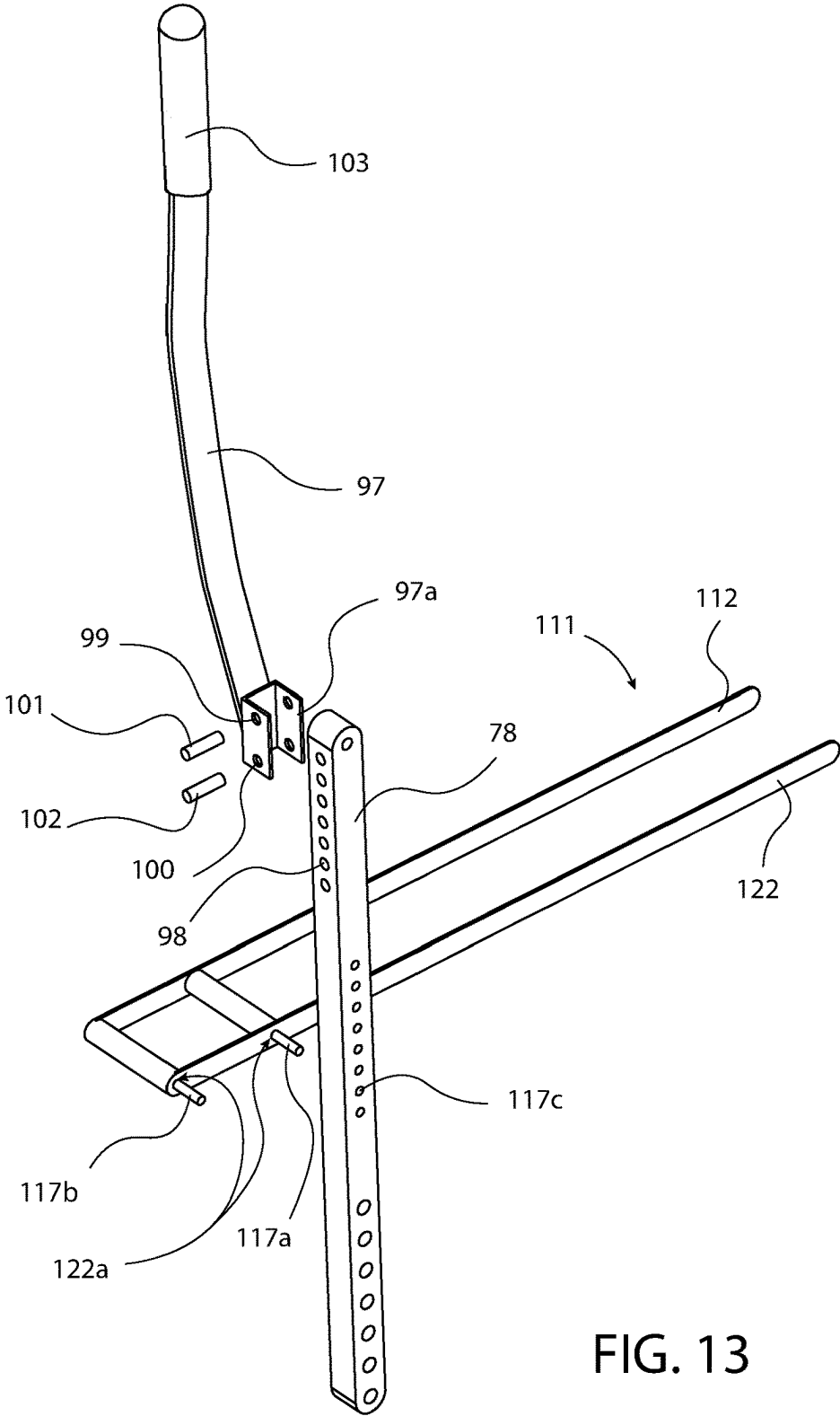

FIG. 13

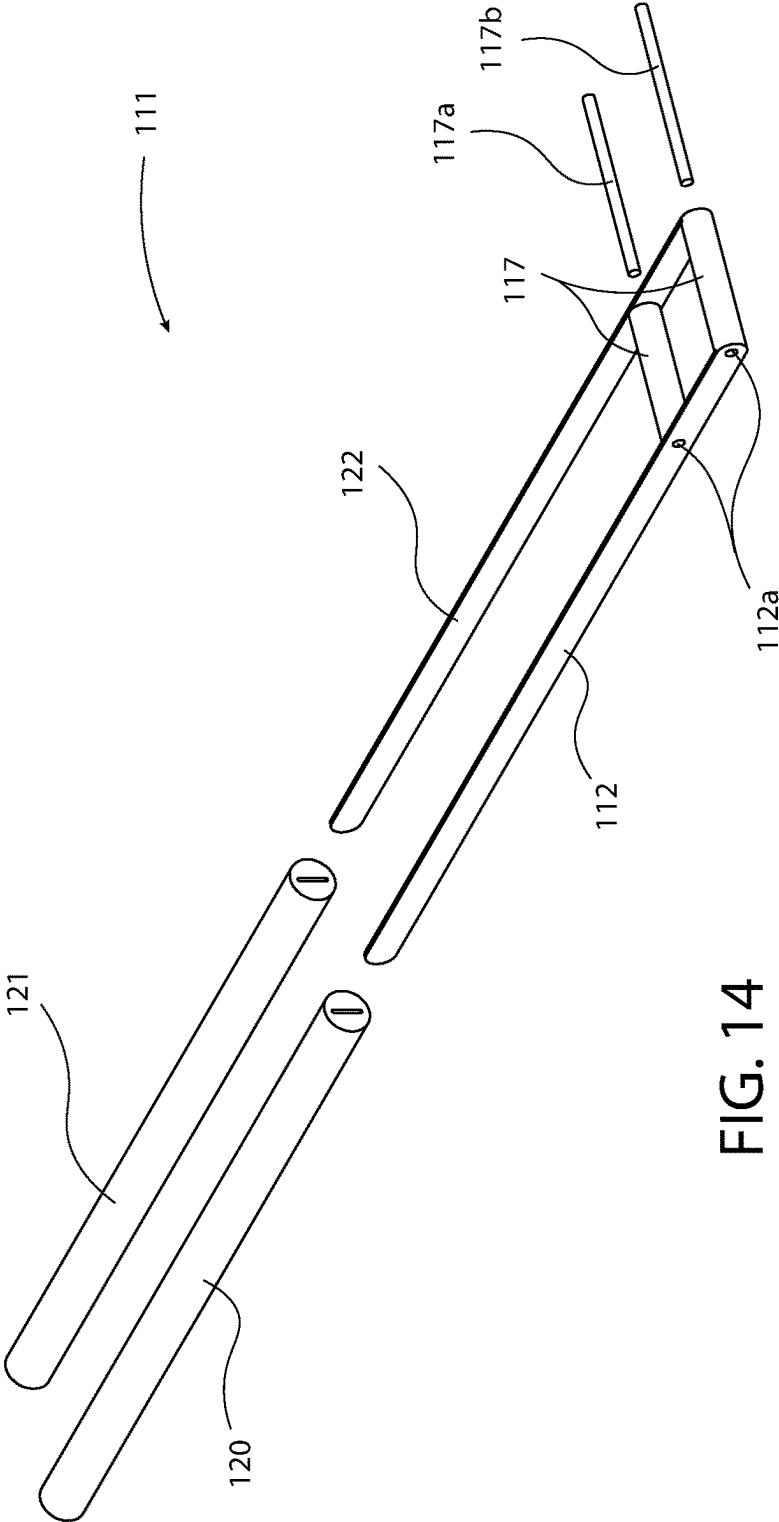

FIG. 14

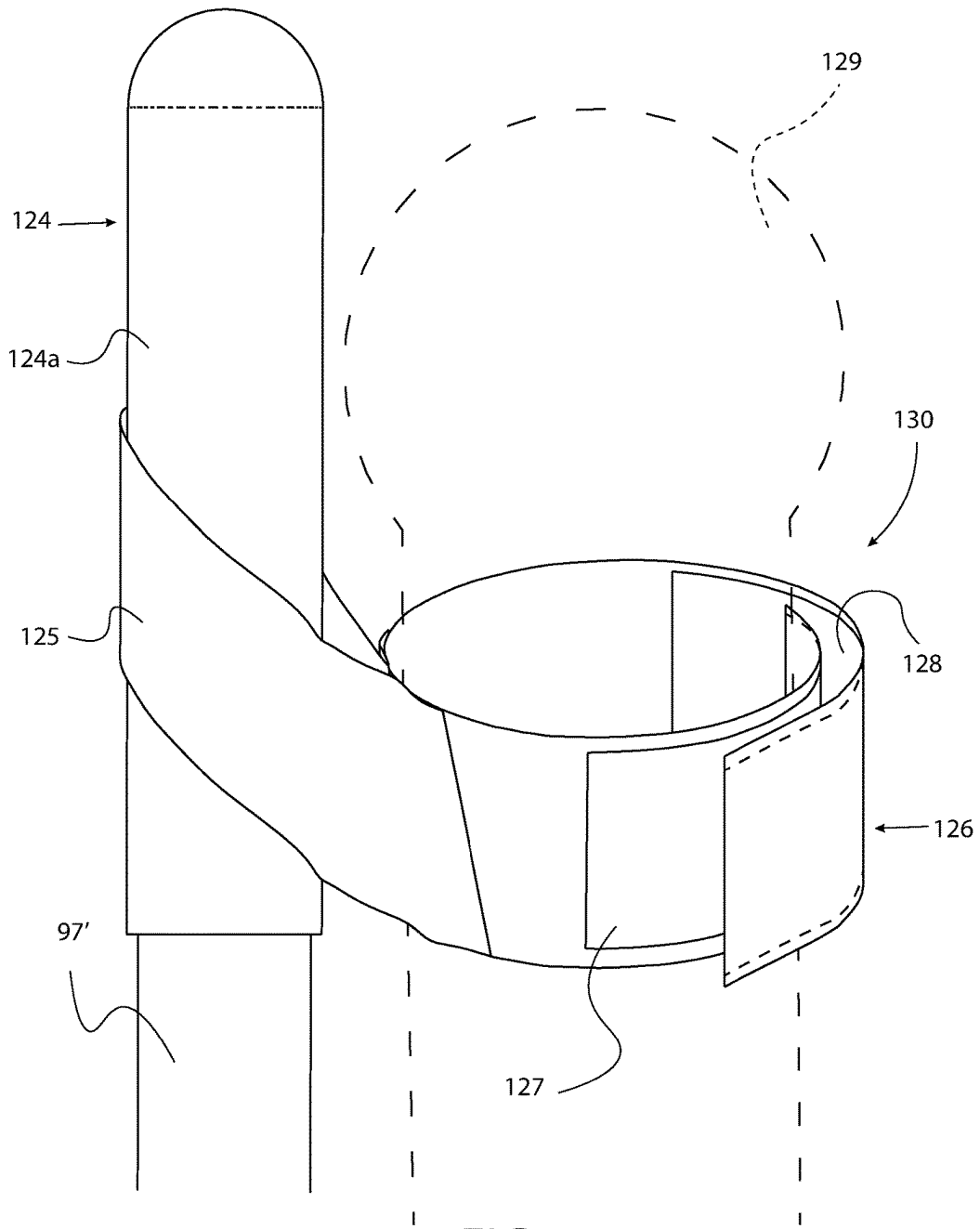

FIG. 15

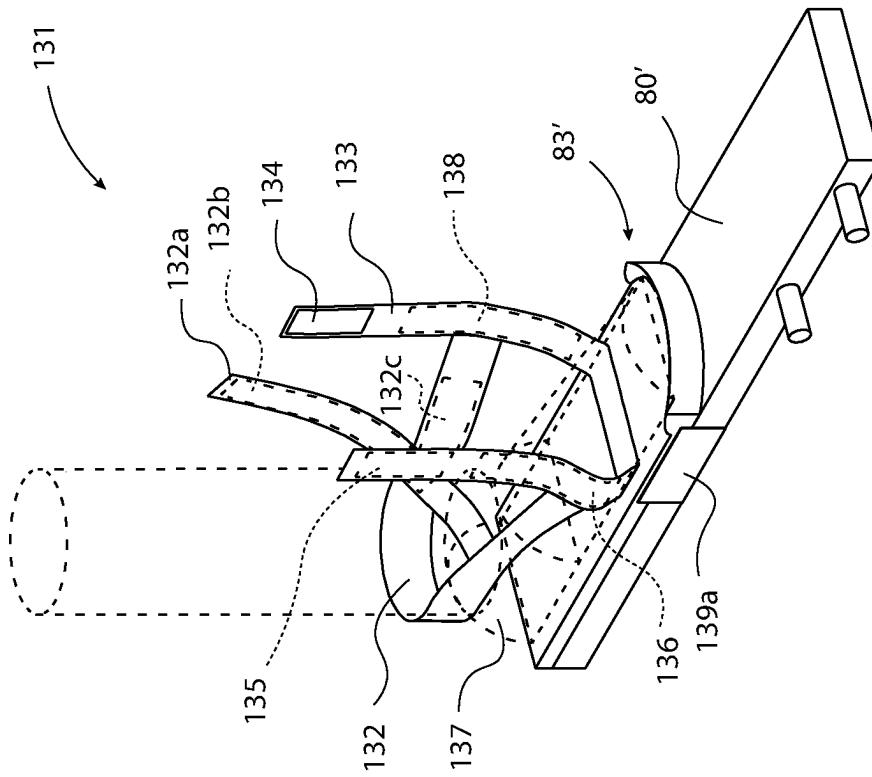

FIG. 16B

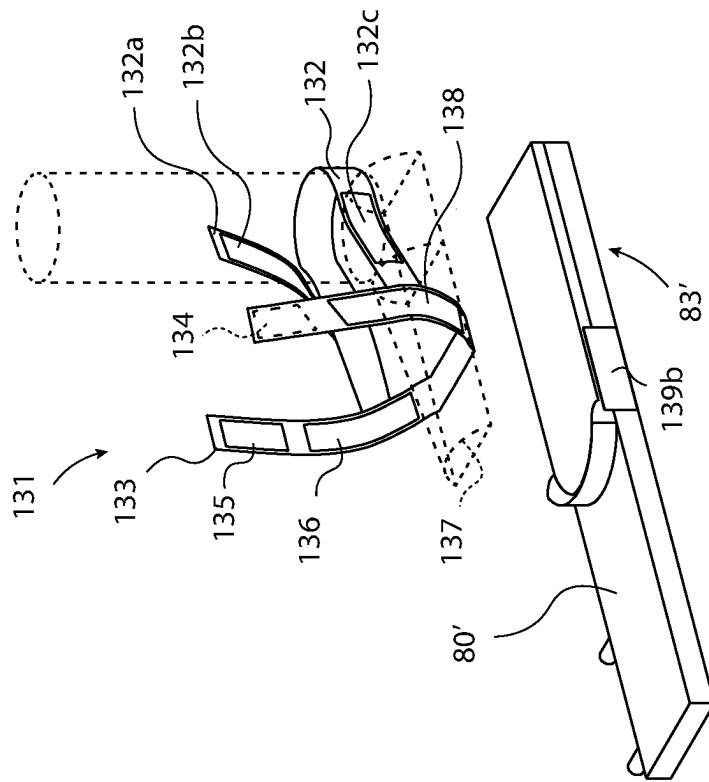

FIG. 16A

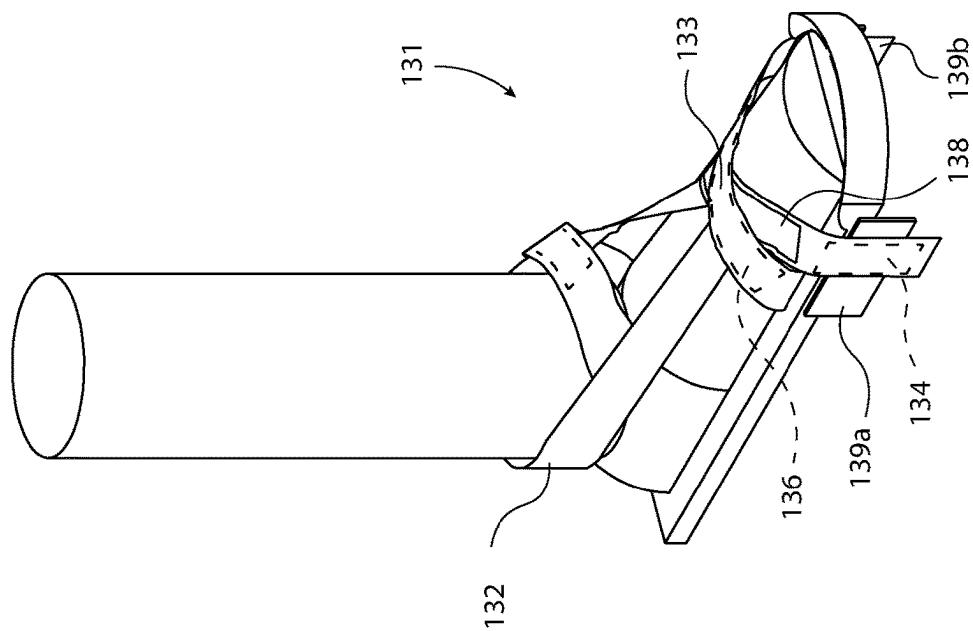

FIG. 17B

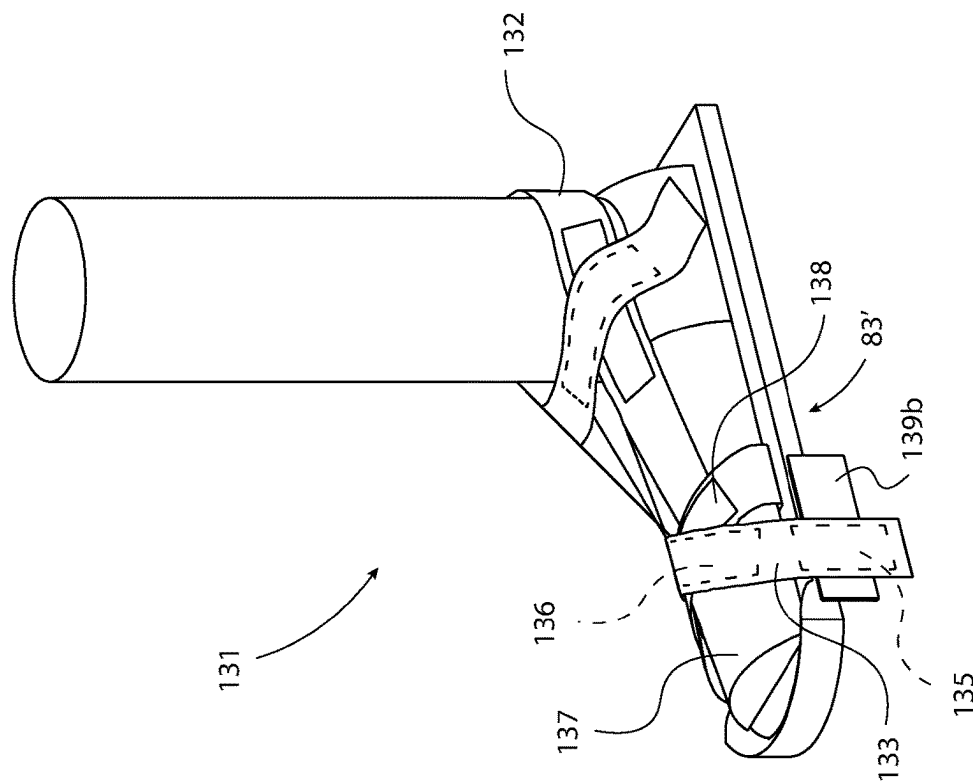

FIG. 17A

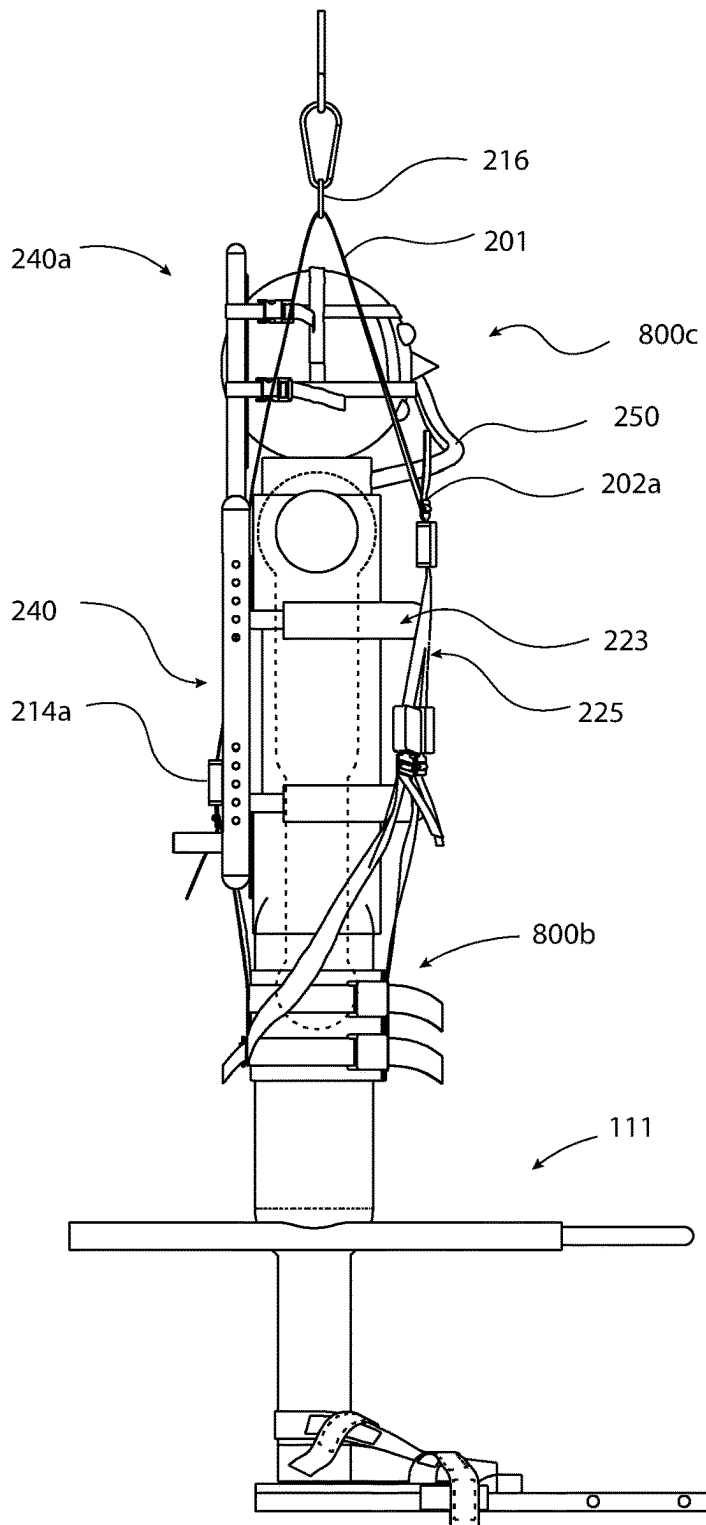

FIG. 18

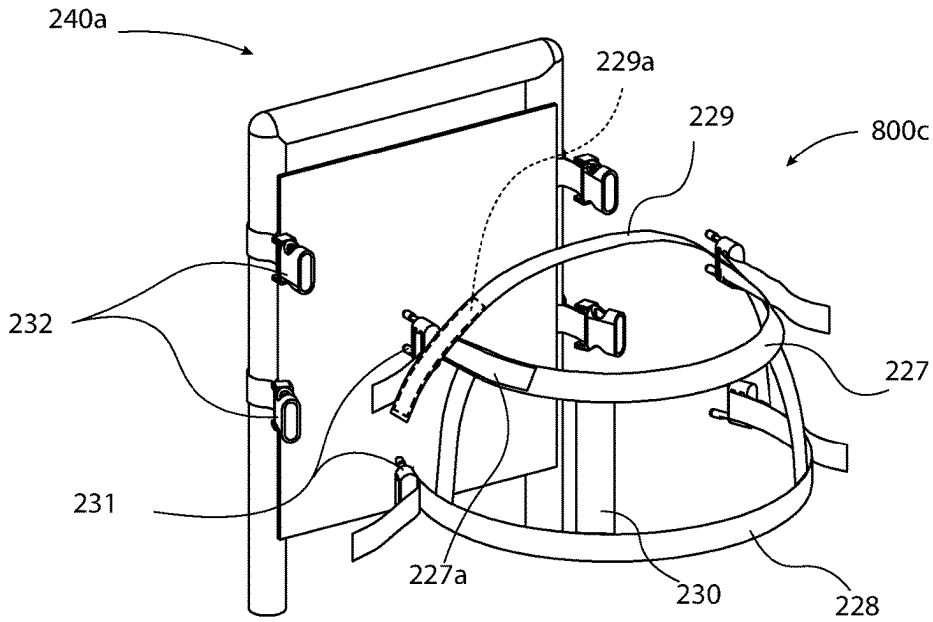

FIG. 18A

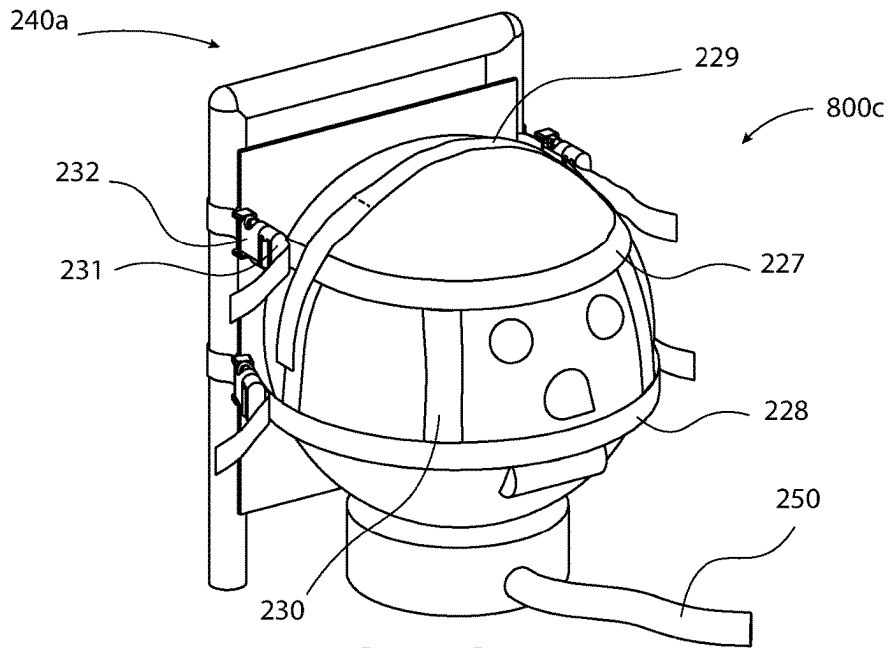

FIG. 18B

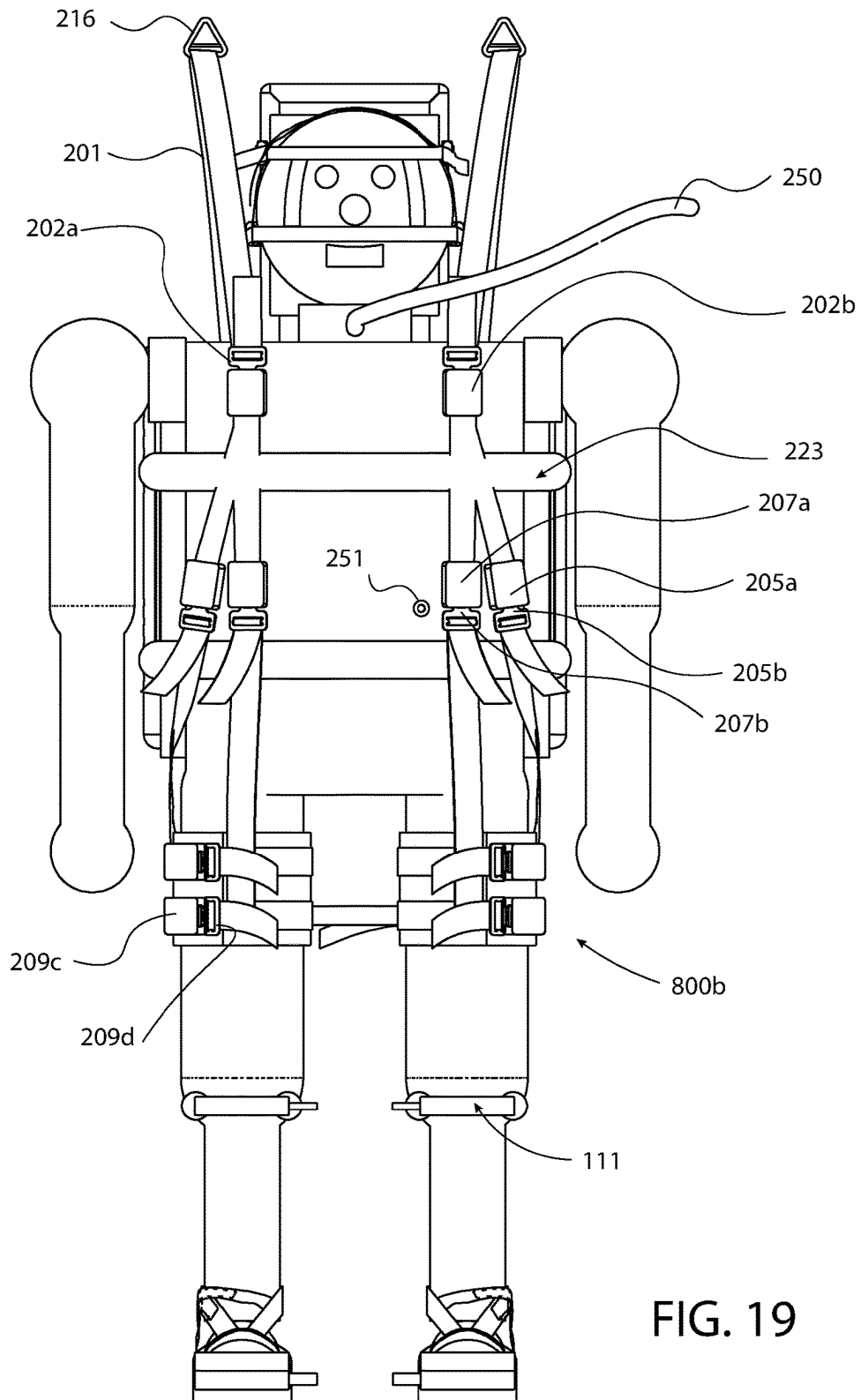

FIG. 19

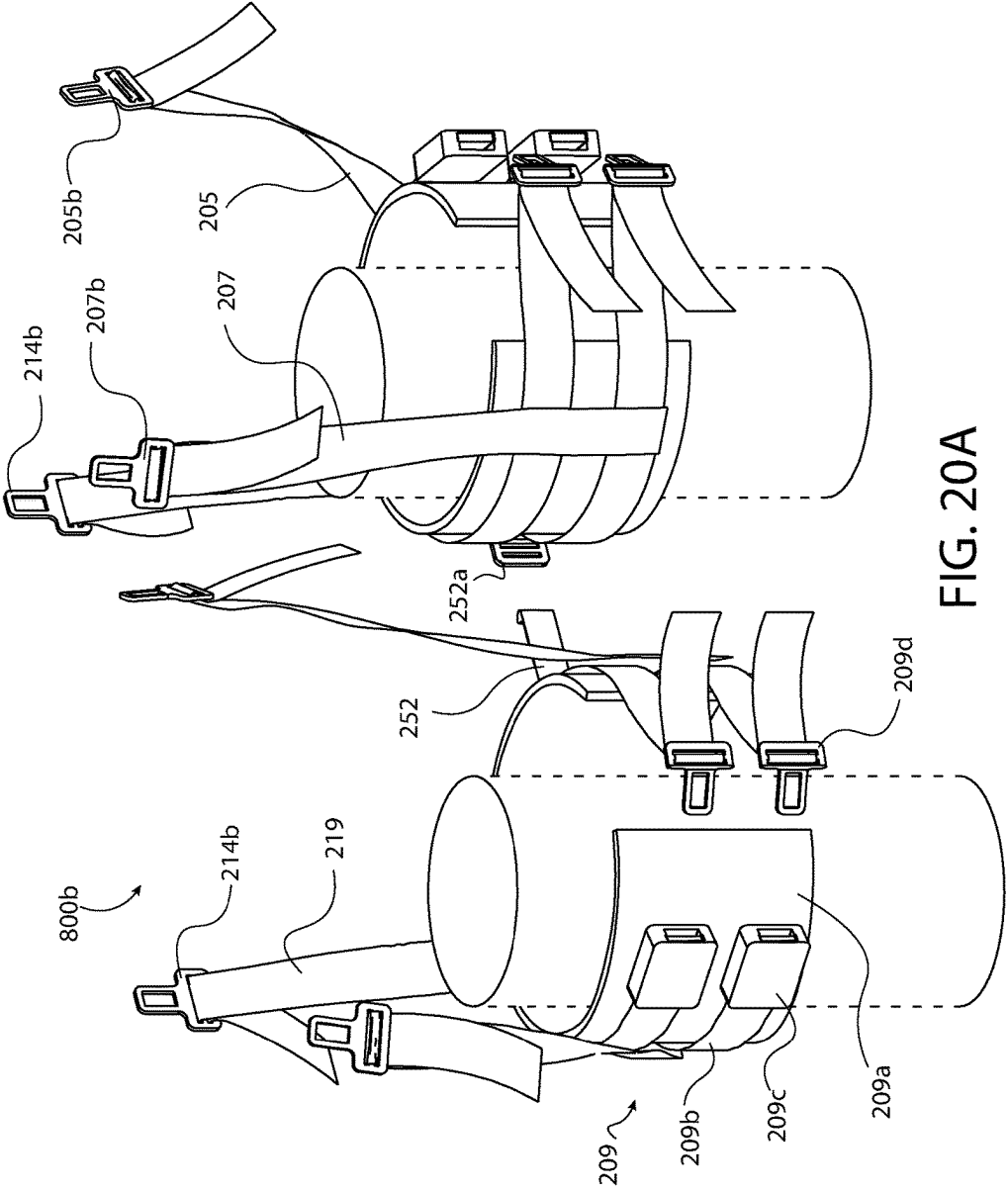

FIG. 20A

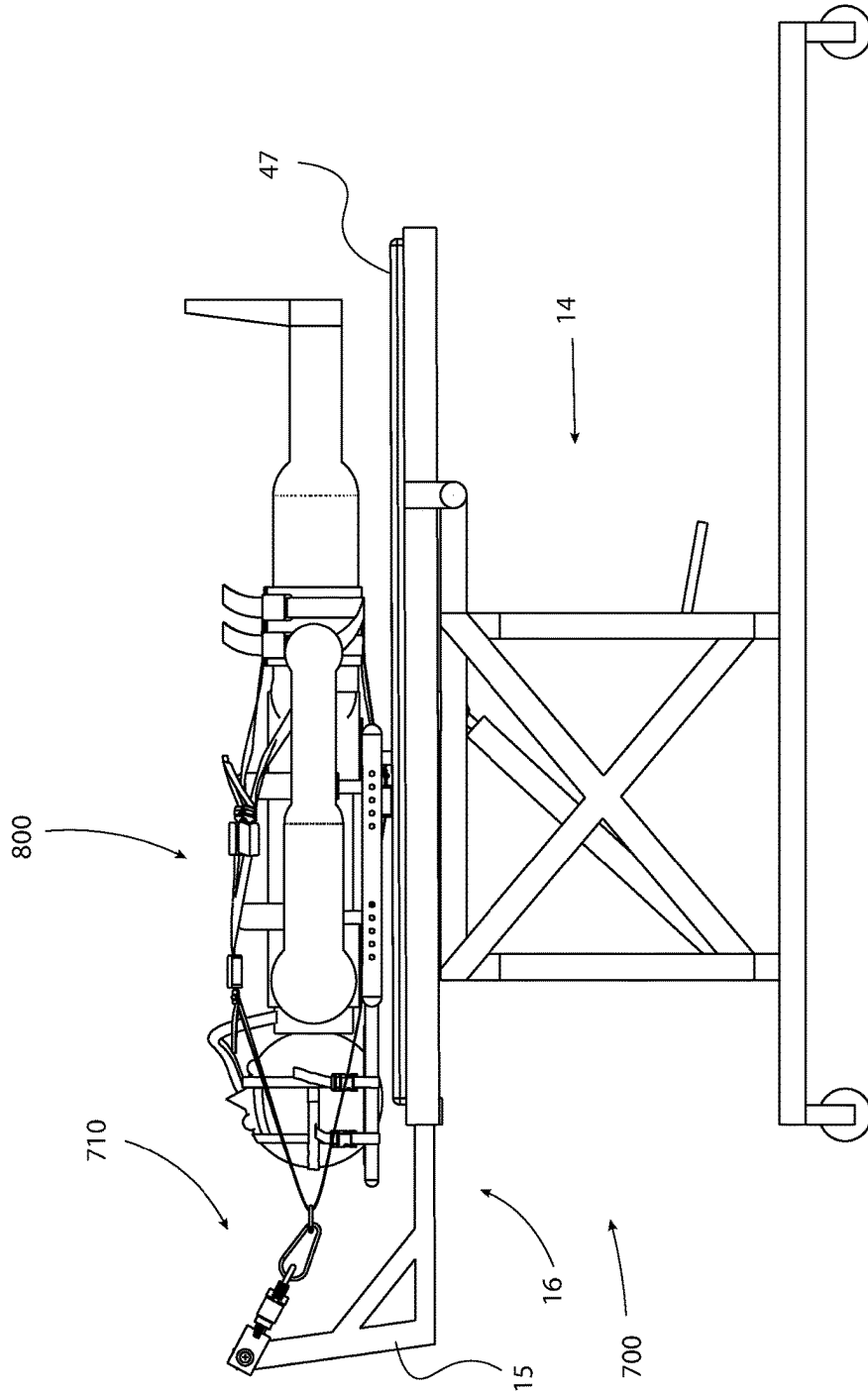

FIG. 21

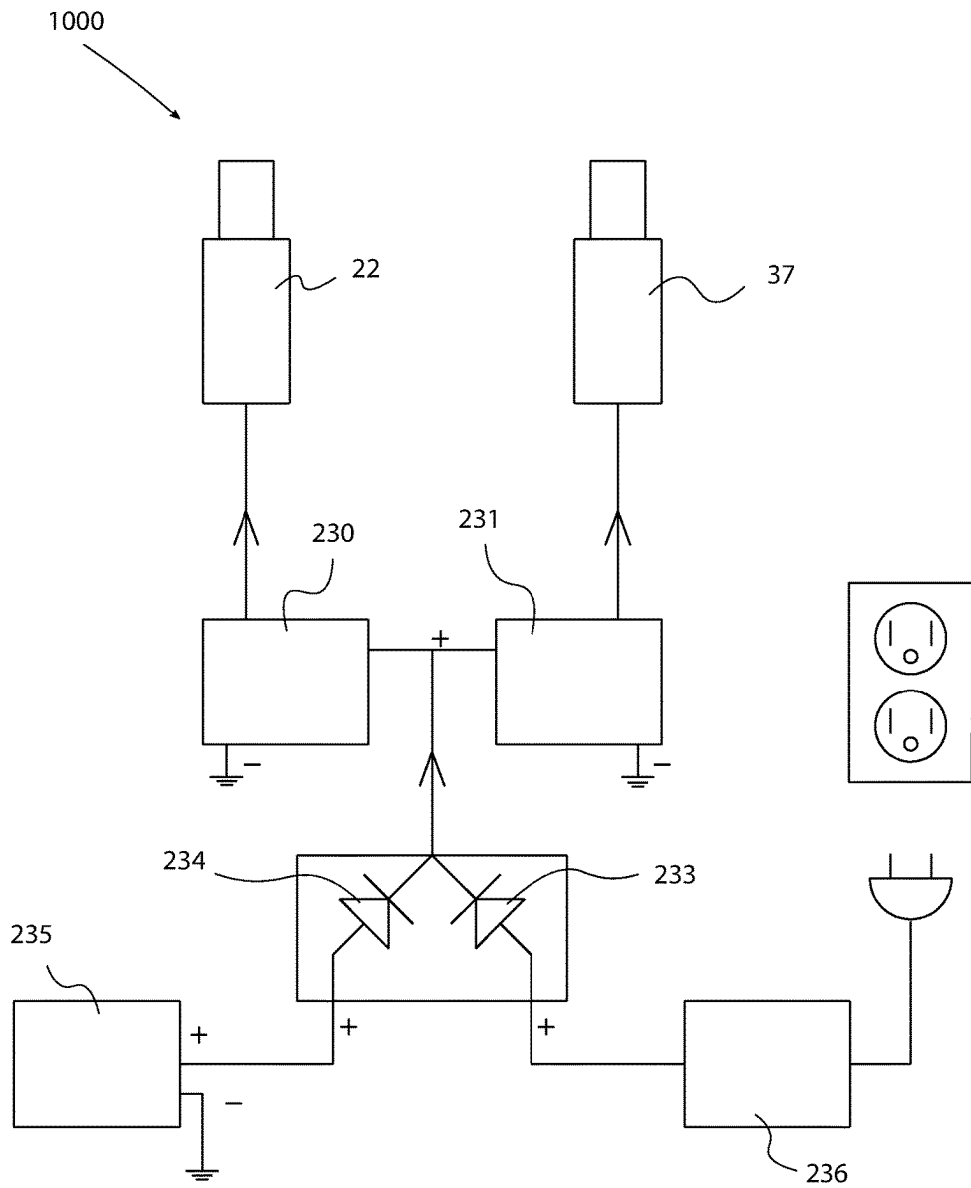

FIG. 22

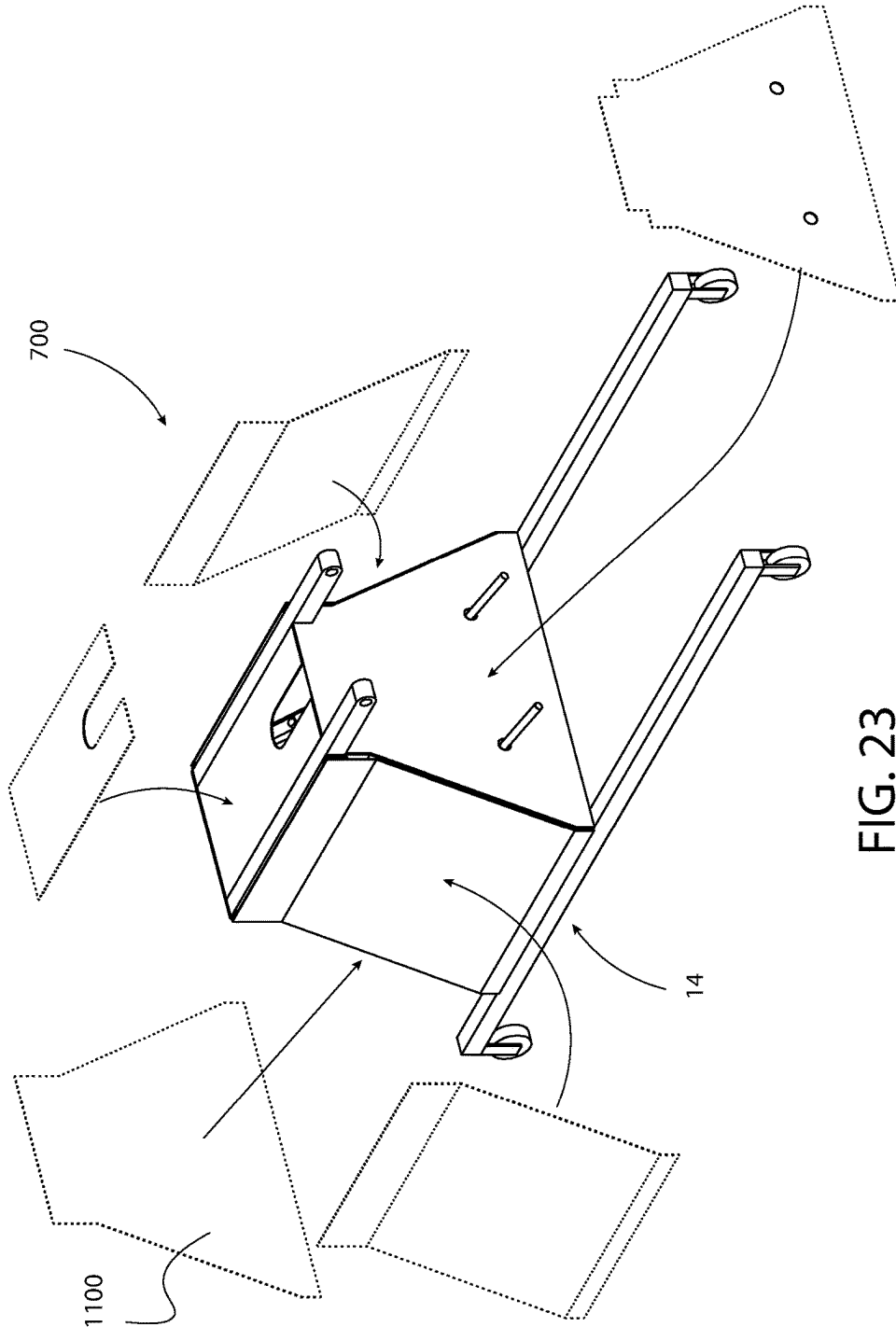

FIG. 23

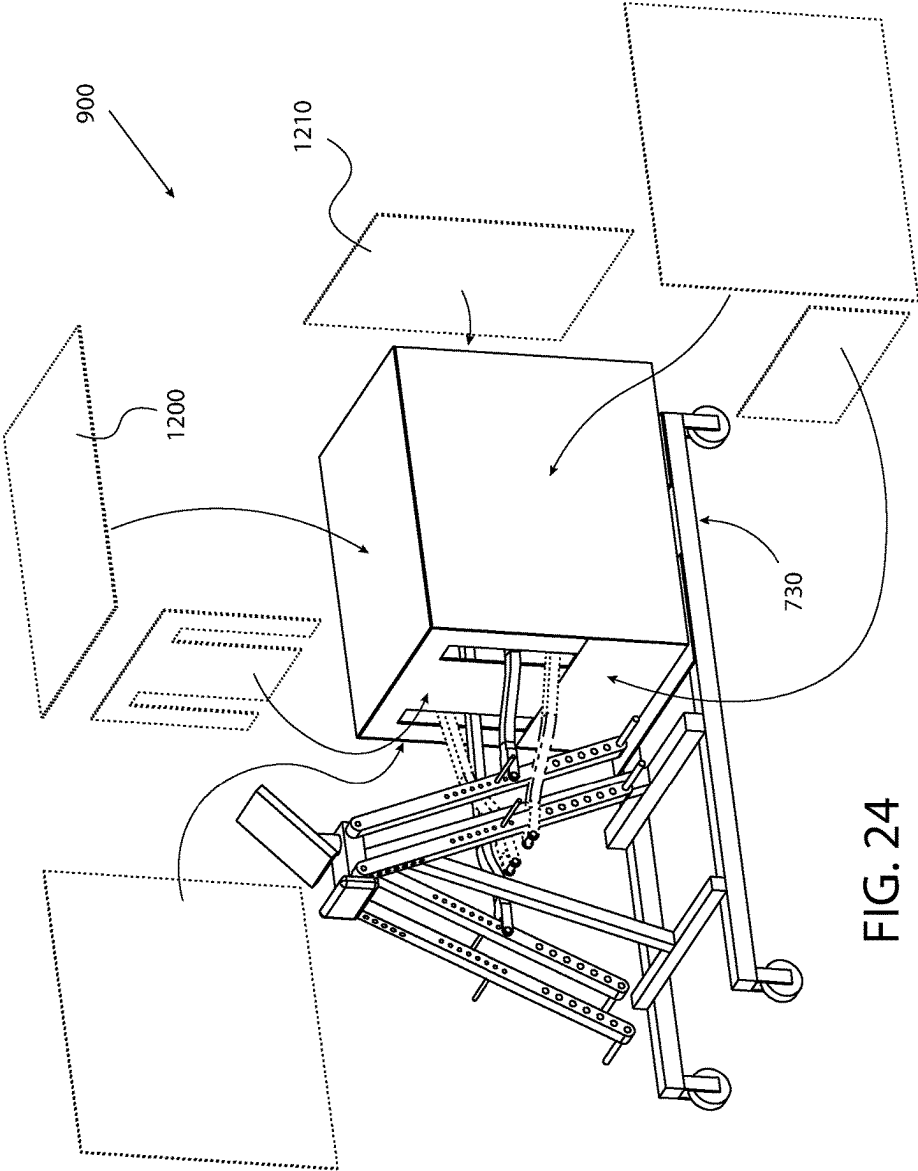

FIG. 24

**MOTORIZED AIR WALKER AND
SUSPENSION SYSTEM FOR PARALYZED
PERSONS**

CROSS-REFERENCE TO RELATED
APPLICATIONS

This application is a 35 U.S.C. § 371 National Phase filing claiming the benefit of and priority to International Application No. PCT/US2015/018852, filed on Mar. 5, 2015, which claims priority to, and the benefit of, U.S. Provisional Patent Application No. 61/967,016, filed on Mar. 7, 2014, the entire contents of each of which are hereby incorporated by reference herein.

This application is also a Continuation of U.S. patent application Ser. No. 14/639,247, filed on Mar. 5, 2015 which claims priority to, and the benefit of, U.S. Provisional Patent Application No. 61/967,016, filed on Mar. 7, 2014, the entire contents of each of which are hereby incorporated by reference herein.

BACKGROUND

Technical Field

The present disclosure relates generally to apparatus and methods for gait rehabilitation and, in particular, to an apparatus for locomotor therapy and method of operating the same.

Background of the Disclosure

Spinal cord injuries affect approximately 12,000 individuals within the United States each year. Such injuries, as well neurological disorders, can have a devastating effect on the lives of those suffering from such an affliction, especially those who are young. Recent innovations in the area of gait rehabilitation have explored the use of locomotor therapy for those suffering from stroke, spinal cord injury, Parkinson's disease, cerebral palsy, traumatic brain injury, and the like. Using locomotor therapy, an individual can retrain the brain, through repetitive practice of complex gait stroke, to re-learn the motor skills required to effectuate locomotion.

Many locomotor therapy machines utilize body weight support systems to maintain the patient's position relative to a device for effectuating movement of the limbs. This is accomplished by supporting the patient through use of a body harness and a gantry placed over the ground or more often a treadmill. While this sufficiently unloads the patient's legs and maintains the body position of the patient, significant effort is required by the clinician to guide the patient into the harness and into an appropriate position within the machine. Additionally, the clinician is often required to manually effectuate movement of the patient's limbs until the patient has reached a stage where sufficient locomotive ability is gained to operate the system on their own.

One example of a system as described in the foregoing is disclosed in U.S. Pat. No. 6,666,798. The disclosed locomotor therapy system is of the body support system treadmill training type and utilizes a gantry and harness to support the patient over a treadmill. The system requires the aid to be positioned either behind or in front of the patient, with the clinician's legs being coupled to the patient's legs by a series of brackets. Through this system, the clinician's gait is duplicated by the patient, thereby effectuating locomotion.

This type of system often places considerable strain on the therapist. Additionally, it is difficult to maintain consistent gait as locomotion is effectuated manually by the clinician.

An additional limitation is the gait of the clinician is often mismatched with that of the patient due to differing body sizes.

In order to mitigate some of these issues, driven gait orthosis have been developed to robotically control the patient's gait as the patient walks on the treadmill. These devices utilize the body weight support systems as described above, with the addition of the driven gait orthosis being secured to the patient's legs. This system removes the need for the clinician to manually effectuate locomotion in addition to providing consistent gait.

One example of a driven gait orthosis system is disclosed in U.S. Pat. No. 6,821,233. The disclosed driven gait orthosis system utilizes a body support system and a treadmill consistent with the previous disclosure. However, replacing the clinician is a driven and controlled orthotic device, which guides the legs in a physiological pattern of movement. Additionally, the orthotic device can be adjusted and adapted to different patients.

While this type of system eliminates some of the previously disclosed issues, significant limitations still remain. There remains the issue of guiding and lifting the patient into the correct position in order to effectively use the system. Additionally, significant effort is required to secure and adjust the driven gait orthosis to the patient. Moreover, a limitation of both disclosed systems is the patient being a passive part of the system, i.e. effectuation of the movement of the legs is by means of external forces.

It would be preferable, however, if the clinician had the ability to allow the patient to effectuate their own locomotion, the ability to easily transfer the patient to and from the locomotor therapy system, the ability to easily adapt the system to each patient's physiological makeup, and the ability to rehabilitate paraplegic and quadriplegic patients without transferring the patient to separate machines. As such, there remains a need for an improved locomotor therapy system.

SUMMARY

The present disclosure relates to patient rehabilitation.

According to an aspect of the present disclosure, a system for patient rehabilitation is provided and includes an articulating bed, a walker, and a harness.

The articulating bed includes a first movable frame, a bed, and a suspension system. The bed includes a first and second end, wherein the bed is rotatably supported by the first movable frame at a first end. The bed is configured to be selectively articulated to an inclined position. The suspension system is disposed within the bed and includes a frame including proximal and distal ends. The frame is translatably supported by the bed and includes an arm extending from the proximal end thereof. The arm is configured to support a harness and the suspension system is selectively adjustable along a longitudinal axis defined by the first and second ends of the bed.

The walker includes a second movable frame, a pair of legs and a reciprocator. The pair of legs includes an upper and lower end, wherein each of the pair of legs is rotatably supported by the second movable frame. Each of the pair of legs includes a foot support on the lower end thereof and a gripping portion for a patient's hand on the upper end thereof.

The reciprocator includes a motor, a flywheel frame, and a flywheel rotatably supported by the flywheel frame. The motor is rigidly secured to the second movable frame and includes a sprocket that is in mechanical cooperation with

the motor. The flywheel frame is rigidly secured to the second movable frame. The flywheel is in operative communication with the sprocket and at least one of the pair of legs.

The harness includes a plurality of straps for securing the torso, legs, head, hand, arms, and feet of a patient. The plurality of straps are selectively engageable with the suspension system of the articulating bed and are selectively adjustable to accommodate a variety of patient sizes.

The articulating bed may include an actuator for articulation.

The actuator may be selected from the group consisting of a hydraulic actuator, a pneumatic actuator, and an electric actuator.

The foot support may be adjustable to accommodate a variety of patient sizes.

The second movable frame may include a knee support disposed on each of the pair of legs. The knee support may be configured to support the patient's knee and may be adjustable to accommodate a variety of patient sizes.

The frame of the suspension system may be translated by an actuator. The actuator may be selected from the group consisting of a hydraulic actuator, a pneumatic actuator, and an electric actuator.

The reciprocator may include a pair of adjustment bars that are rigidly secured to a first side and a second side of the flywheel. A pair of adjustment bars may radially extend from a center point of the flywheel in opposing directions and may include a plurality of holes defined therethrough extending along a longitudinal axis of each of the pairs of adjustment bars.

The system may further include a pair of pivot blocks configured and dimensioned to advance over each of the pair of adjustment bars. The pivot blocks may be selectively engageable with one of the plurality of holes of the adjustment bars. Each of the pair of pivot blocks may include an axle extending normally therefrom.

The system may further include a pair of control members having proximal and distal ends. The proximal end of each of the pair of control members may be rotatably supported by one of the pair of legs of the walker. The distal end of the pair of control members may be rotatably supported by the axle of the pivot block.

The height of the gripping portion of the pair of legs may be selectively adjustable.

The motor may include a speed reduction gearbox.

The system may further include a drive transmitting device to transmit the rotation of the sprocket to the flywheel.

The drive transmitting device may be a chain or a belt.

According to a further aspect of the present disclosure, a system for patient rehabilitation is provided. The system includes an articulating bed having a first movable frame; a bed including a first and second end, wherein the bed is rotatably supported by the first movable frame at a first end, wherein the bed is configured to be selectively articulated to an inclined position; and a suspension system. The suspension system is disposed within the bed. The suspension system includes a frame including proximal and distal ends. The frame is translatably supported by the bed, and includes an arm extending from the first end of the bed. The suspension system is selectively adjustable along a longitudinal axis between the first and second ends of the bed.

The system may further include a walker including a second movable frame; a pair of legs including an upper and lower end, wherein each of the pair of legs is rotatably supported by the second movable frame, wherein each of the

pair of legs includes a foot support on the lower end thereof, wherein each of the pair of legs includes a gripping portion for a patient's hand on the upper end thereof.

The walker further includes a reciprocator including a motor, wherein the motor is rigidly secured to the second movable frame, wherein the motor includes a sprocket, wherein the sprocket is in mechanical cooperation with the motor; a flywheel frame, wherein the flywheel frame is rigidly secured to the second movable frame; and a flywheel rotatably supported by the flywheel frame, wherein the flywheel is in operative communication with the sprocket, wherein the flywheel is in operative communication with at least one of the pair of legs.

The system may further include a harness, including a plurality of straps for securing the torso, legs, head, hands, arms, and feet of a patient, wherein the plurality of straps are selectively engageable with the suspension system of the articulating bed, wherein the straps are selectively adjustable to accommodate a variety of patient sizes.

The bed may define a plane, wherein the bed is articulatable from a first orientation wherein the plane of the bed is parallel to a floor supporting the system, and second inclined orientation angled with respect to the first orientation.

The second inclined orientation may be orthogonal to the first orientation.

The suspension system may include a harness supported by the arm.

According to another aspect of the present disclosure, a method for patient rehabilitation is provided and includes providing an articulating bed, a walker, and a harness.

The articulating bed includes a first movable frame, a bed, and a suspension system for supporting a harness. The bed may be selectively articulated to an inclined position. The suspension system may be selectively adjustable to accommodate varying patient sizes.

The walker includes a second movable frame, a pair of legs, and a reciprocator. Each of the pair of legs includes a foot support on a bottom end thereof. Each of the pair of legs further includes a gripping portion for a patient's hand on an upper end thereof.

The harness is selectively engageable with the suspension system and is selectively adjustable to accommodate a variety of patient sizes.

The method further includes lying a patient down on the articulating bed, securing the harness around the torso, legs, and head of the patient, adjusting the height of the suspension system to accommodate the size of the patient, securing the harness to the suspension system, approximating the first movable frame and the second movable frame, articulating the articulating bed to an inclined position, and adjusting the suspension system to accommodate the size of the patient such that the patient may utilize the walker.

The reciprocator may further include a pair of adjustment bars, a pair of pivot blocks, and a pair of control members. Adjustment of the pivot blocks may cause a stroke of the walker to increase or decrease in order to accommodate a gait of the patient.

The gripping portion of each of the pair of legs may be selectively adjustable in height. Selective adjustment of the height of the gripping portion of each of the pair of legs may increase or decrease the stroke of the pair of legs of the walker in order to accommodate a gait of the patient.

The method may further include adjusting the foot support to accommodate the size of the patient.

The second movable frame may include a knee support disposed on each of the pair of legs. The knee support may

5

be configured to support the patient's knee and may be adjustable to accommodate the size of the patient.

BRIEF DESCRIPTION OF THE DRAWINGS

The above and other aspects, features, and advantages of the present disclosure will become more apparent in light of the following detailed description when taken in conjunction with the accompanying drawings in which:

FIG. 1 is an elevation view of a patient rehabilitation system according to an embodiment of the present disclosure;

FIG. 1A is a perspective view of the patient rehabilitation system of FIG. 1;

FIG. 2 is a plan view of the patient rehabilitation system of FIG. 1;

FIG. 3 is a side, perspective view, with parts separated, of a bed lifter of the patient rehabilitation system of FIG. 1;

FIG. 4 is a side view, with parts separated, of the bed lifter of FIG. 3;

FIG. 4A is an enlarged view of the area of detail of FIG. 4;

FIG. 5 is a perspective view, with parts separated, of a suspension system of the patient rehabilitation system of FIG. 1;

FIG. 5A is side view of a U-bracket of the suspension system of FIG. 5;

FIG. 5B is a front view of the U-bracket of FIG. 5A;

FIG. 6A is a side, partial cutaway view of a wagon of the bed lifter of FIG. 3;

FIG. 6B is a plan view of the wagon of FIG. 6A;

FIG. 7 is a front, perspective view of a motorized air walker of the patient rehabilitation system of FIG. 1;

FIG. 7A is a perspective view of an adjustment system of the motorized air walker of FIG. 7, shown in two height positions;

FIG. 8 is a plan view of the motorized air walker of FIG. 7, shown in a neutral or start/end position;

FIG. 9 is a rear view of the motorized air walker of FIG. 7;

FIG. 10 is a perspective view of a reciprocator of the motorized air walker of FIG. 7;

FIG. 11 is a perspective view of a walker support frame of the motorized air walker of FIG. 7;

FIG. 12A is side view of a pivot block of the motorized air walker of FIG. 7, shown in an initial, closed state;

FIG. 12B is a side view of the pivot block of FIG. 12A, shown in a second, open state;

FIG. 12C is a perspective view of the pivot block of FIG. 12A, with parts separated;

FIG. 13 is a perspective view of a leg member and hand supporting tube of the motorized air walker of FIG. 7;

FIG. 14 is a perspective view of a knee guiding mechanism of the motorized air walker of FIG. 7;

FIG. 15 is a side view of a left hand strap of the motorized air walker of FIG. 7;

FIG. 16A is a left/outside, perspective view of a left foot strap of the motorized air walker of FIG. 7, shown in an open position;

FIG. 16B is a right/inside, perspective view of the left foot strap of FIG. 16A, shown in an open position;

FIG. 17A is a left/outside, perspective view of the left foot strap of FIG. 16A, shown in a closed position;

FIG. 17B is a right/inside, perspective view of the left foot strap of FIG. 16B, shown in a closed position;

FIG. 18 is a side view of a harness of the patient rehabilitation system of FIG. 1;

6

FIG. 18A is a perspective view of a head harness of the harness of FIG. 18;

FIG. 18B is a perspective view of the head harness of FIG. 18A, shown secured to a patient's head;

FIG. 19 is a front view of the harness of FIG. 18;

FIG. 20 is a perspective view of the harness of FIG. 18, with parts separated;

FIG. 20A is a front, perspective view, of a leg harness of the harness of FIG. 20;

FIG. 21 is an elevation view of the patient rehabilitation system of FIG. 1, with a patient in a supine position;

FIG. 22 is a schematic of a battery back-up system of the patient rehabilitation system of FIG. 1;

FIG. 23 is a perspective view of a frame of the patient rehabilitation system of FIG. 1, shown with an enclosure; and

FIG. 24 is a perspective view of the motorized air walker of FIG. 7, shown with an enclosure.

DETAILED DESCRIPTION OF THE EMBODIMENTS

Embodiments of the present disclosure are now described in detail with reference to the drawings in which like reference numerals designate identical or corresponding elements in each of the several views. As used herein, the term "clinician" refers to a doctor, a nurse or any other care provider and may include support personnel. Additionally, the term "person" refers to a patient. The term "proximal" will refer to the portion of the device, component, or patient thereof that is closer to the clinician and the term "distal" will refer to the portion of the device, component, or patient thereof that is farther from the clinician. The term "cephalic" will refer to the portion of the device, component, or portion of the body of a patient that is towards the head of the patient and the term "caudal" will refer to the portion of the device, component, or portion of the body of a patient that is towards the feet of the patient. Additionally, in the drawings and in the description that follows, terms such as front, rear, upper, lower, top, bottom, and similar directional terms are used simply for convenience of description and are not intended to limit the disclosure. In the following description, well-known functions or constructions are not described in detail to avoid obscuring the present disclosure in unnecessary detail.

As an initial matter, some elements are symmetric about the center of the machine 600 as viewed from above (i.e. plan view). With reference to FIG. 2, the center of the machine 600 defines an axis "A" bisecting horizontal base member 3 of frame 14 of bed lifter 700 and extending horizontally through motorized air walker 900. Axis "A" thereby bisects the machine 600 into left and right halves. As will be discussed in further detail below, each module (bed lifter 700, motorized air walker 900, and harness 800) is similarly bisected by a respective axis, such that the respective axes are co-axial when each module is oriented in their final positions.

Referring now to the drawings, the machine 600, according to the present disclosure, includes three modules. Module one, the "bed-lifter" 700, is presented within FIGS. 3, 4, 4A, 5, and 6. Module two, "the motorized air walker" 900, is illustrated within FIGS. 7-14. Module three, "the harness" 800, is illustrated within FIGS. 15-20A. While the following description relates to the use of the "bed-lifter" 700 in cooperation with "the motorized air walker" 900, it is contemplated and within the scope of the present disclosure that the "bed-lifter" 700 may be used independently of "the

motorized air walker” 900, may be used as a standalone system (wherein the patient walks along the floor and pulls the “bed-lifter” 700 along the floor), or may be used in cooperation with other rehabilitation systems, such as, for example, a treadmill, a cross-country skiing system, an exercise bicycle, an elliptical machine or the like. It is envisioned that the use of the “bed-lifter” 700 may be in any situation that a person will benefit from being in a vertical position while exercising or rehabilitating, wherein the body of the person is supported.

FIGS. 1, 1A, and 2 illustrate the overall external appearance of the bed-lifter 700 including frame 14, which includes casters 2 disposed on the underside thereof, and a schematic of motorized air walker 900, including walker frame 69, which includes casters 70, 71. Casters 70, 71 include a braking mechanism, wherein the braking mechanism may be any means known in the art to effectuate braking or inhibit movement of the walker frame 69. The casters 2, which may include a brake, are widely available on the market and permit the bed-lifter 700 to move as needed as will be disclosed herein.

Referring now to FIGS. 3 and 4, the frame 14 of bed-lifter 700 includes horizontal base members 1 and 1', which are rigidly connected with horizontal base members 3 and 3'. Extending vertically from horizontal base member 3' are vertical support members 4 and 6, which are rigidly connected thereto. Extending vertically from horizontal base member 3 are vertical support members 5 and 7, which are rigidly connected thereto. Bed frame support 8, extending parallel to horizontal base member 1', is rigidly connected to vertical support members 6 and 7, whereas bed frame support 9, extending parallel to horizontal base member 1, is rigidly connected to vertical support members 4 and 5. Diagonal support members 10 and 11 are rigidly connected to vertical support members 4 and 5 and are configured to provide frame 14 with stability along axis “A”. Similarly, diagonal support members 12 and 13 are rigidly connected to vertical support members 6 and 7 and are configured to provide frame 14 with stability along axis “A”. Diagonal support members 10 and 11, and diagonal support members 12 and 13 may be configured such that diagonal support member 10 and 11, and 12 and 13, respectively, intersect. Providing transverse stability (i.e. stability normal to axis “A”) to frame 14 are truss members 4', 5', 6', and 7'. Truss members 5' and 7' are rigidly connected to, and extend vertically from, horizontal base member 3, and truss members 4' and 6' are rigidly connected to, and extend vertically from, horizontal base member 3' such that truss members 4', 5', 6', and 7' form an acute angle with respect to vertical support members 4, 5, 6, and 7, respectively. Additionally, truss members 4', 5', 6', and 7' are rigidly secured at an upper end to respective vertical support members 4, 5, 6, and 7. In order to facilitate easy maneuverability of frame 14, casters 2 may be swiveling and may include a braking mechanism as discussed in the foregoing. In one embodiment, frame 14 includes four casters 2.

Referring back to FIG. 1, an embodiment of bed frame 18 is illustrated as being in an inclined position. Pivot 31 is rigidly secured to a stiffening member 19 which is rigidly secured to an underside of bed frame 18 and pivot 32 is rigidly connected to horizontal base member 3 (FIG. 3). Telescoping actuator 22 is interposed between horizontal base member 3 and the stiffening member 19 of bed frame 18 and is mechanically secured thereto by pivots 31, 32. Telescoping actuator 22 may be any telescoping actuator capable of effectuating linear movement, such as pneumatic, hydraulic, electric, push/pull, or the like.

As illustrated in FIGS. 3 and 4, bed frame 18 includes horizontal beams 20 and 20'. In one embodiment, horizontal beams 20 and 20' include a C-shape profile 20a and 20a', although other suitable profiles are contemplated. Bed frame 18 also includes stiffening member 19' extending normal to horizontal beams 20 and 20' and being rigidly connected thereto. Transverse support 21 is interposed between horizontal beams 20 and 20' and is rigidly connected thereto thereby forming the three sides of bed frame 18. Horizontal beams 20 and 20' include closeout plates 20b and 20b' rigidly secured thereto and immediately adjacent to transverse support 21. Lugs 33 and 34 include through-holes 33a and 34a (FIGS. 3, 4A) and are rigidly connected to horizontal beam 20 and closeout plate 20b. Lugs 33 and 34 are positioned such that horizontal beam 20 and closeout plate 20b are interposed between lugs 33 and 34. Similarly, lugs 33' and 34' include through-holes 33a' and 34a' and are rigidly connected to horizontal beam 20' and closeout plate 20b'. Similarly to lugs 33 and 34, lugs 33' and 34' are positioned such that horizontal beam 20' and closeout plate 20b' are interposed between lugs 33' and 34'. Frame 18 serves as a housing for wagon 16 as illustrated in FIGS. 1, 3, and 4.

Continuing with FIGS. 3 and 4, an embodiment of wagon 16 is illustrated. Wagon 16 includes a plurality of wheels 27, 28, 29, 30, 27', 28', 29' and 30' that enable wagon 16, when disposed within the C-shaped profile 20a and 20a' of horizontal beams 20 and 20', to translate along axis “A”. As illustrated in FIGS. 4 and 4A, horizontal wheel 29 acts against surface 52 inside horizontal beam 20' while vertical wheel 28 acts against surfaces 49 and 49'. Similar to the foregoing, each corner of wagon 16 may include a horizontal wheel 29', 30, or 30', and a vertical wheel 27, 27', or 28'. Each of wheel 27, 27', 28, 28', 29, 29', 30, and 30' acts upon a respective surface within C-shaped channels 20a and 20a' of horizontal beams 20 and 20' respectively. Each of wheels 27, 27', 28, 28', 29, 29', 30, and 30' permits wagon 16 to translate along axis “A” while loaded thereby allowing adjustment of the height of an arm 15 of wagon 16 with the use of actuator 37 (FIG. 3), as will be discussed in detail below.

It is contemplated that the C-shaped channels and plurality of wheels may be replaced by a plurality of rods and linear bearings, or the like.

As best illustrated in FIGS. 3, 6A, and 6B, wagon 16 includes rigidly mounted extension 38. An end of extension 38 includes arm 15, extending vertically therefrom. Support 36 is rigidly connected to extension 38 and arm 15 such that support 36 acts as a gusset. Actuator 37 is interposed between wagon 16 and bed frame 18 and may effectuate movement of wagon 16 along axis “A” with respect to bed frame 18. Actuator 37 may be any actuator capable of effectuating linear movement, such as pneumatic, hydraulic, electric, or the like. Actuator 37 is mechanically secured to wagon 16 by lug 39 and mechanically secured to bed frame 18 by lug 40. Lug 39 is rigidly connected to wagon 16 and lug 40 is rigidly connected to transverse support 21 of bed frame 18 best illustrated in FIG. 6B.

Referring now to FIGS. 1 and 5-5B, an embodiment of a suspension system 710 of machine 600 is illustrated. In an embodiment, suspension system 710 is supported on bed frame 18 of the “bed lifter” 700. Suspension system 710 includes U-bracket 54, pivot 62, washer 65, nut 64, pin 55, washer 56, hanger 67, washer 56', nut 57, hooks 59 and 59', latching devices 216e, strap hangers 216, and straps 200 and 201 (FIGS. 1 and 5). As illustrated in FIGS. 5A and 5B, U-bracket 54 is rotatably secured to arm 15 of wagon 16 by

pivot **62**, washer **65**, and nut **64**. It is contemplated that a locking device such as a cotter pin or other suitable device may be employed to prevent nut **64** from fully backing off pivot **62**. Referring now to FIG. 5, pin **55** includes a head **55a**, an elongate body **55b** and a threaded shank **55c**. Pin **55** passes through bottom plate **66** of U-bracket **54** (FIG. 5B). Washer **56** is interposed between head **55a** of pin **55** and bottom plate **66** of U-bracket **54**. Center hole **67a** is defined through an upper and lower surface of hanger **67** at a location generally bisecting hanger **67**. Hanger **67** further includes a plurality of holes **68** and **68'** defined through the upper and lower surfaces on opposing ends of hanger **67**. Pin **55** passes through center hole **67a** of hanger **67** and includes washer **56'** and nut **57** thereby preventing hanger **67** from translating axially along pin **55**. It is contemplated that a locking device such as a cotter pin or other suitable device may be employed to prevent nut **57** from entirely backing off pin **55**. Hooks **59** and **59'** pass through a respective one of plurality of holes **68** and **68'** from underneath hanger **67** and are mechanically secured thereto by washers **60**, **60'** and nuts **61**, **61'** respectively (FIG. 5). A plurality of holes **68** and **68'** permit selective positioning of hooks **59** and **59'** thereby permitting adjustment of straps **200** and **201** to accommodate a wide variety of patients using harness **800** (FIG. 5). Although shown as generally having a triangular shape, strap hanger **216** may be any suitable strap hanger known in the art, such as a double bar d-ring, double bar triangle ring, or the like. The gap between members **216a** and **216b** is intended to keep strap **200** in place, so it is not twisting or bunching during storage or during the installation or wearing process. The corner formed by members **216c** and **216d** is intended to properly position latching device **216e**. In operation, member **216a** inhibits strap **200** from twisting, binding, and/or bunching within strap hanger **216**. Latching device **216e** is adapted and/or configured to releasably engage hook **59** and strap hanger **216**, thereby permitting a clinician to easily attach harness **800** to suspension system **710**, and vice versa. It is contemplated that any suitable latching **216e** device may be employed in order to selectively attach strap hanger **216** to hooks **59** and **59'**, such as a carabiner or the like.

Referring now to FIGS. 7-14, an embodiment of motorized air walker **900** is illustrated. As discussed in the foregoing, motorized air walker **900** is bisected by axis "A". Accordingly, and in the interest of brevity, only one side of motorized air walker **900** will be discussed herein.

As illustrated in FIG. 7, motorized air walker **900** includes a base frame **69**. Base frame **69** includes four casters **70**, **70'**, **71**, and **71'**, which may include brakes and the ability to swivel. Frame **69** includes walker support frame **72**. As best illustrated in FIG. 11, walker support frame **72** includes horizontal base members **73** and **73'**. Diagonal support **74** extends from horizontal base member **73** at an incline and is rigidly connected thereto. Vertical support **74'** extends vertically from horizontal base member **73'** and is rigidly connected thereto. Vertical support **74'** terminates on the underside of diagonal support **74** and is rigidly connected thereto. In combination, horizontal base members **73**, **73'**, diagonal support **74** and vertical support **74'** form a free standing frame. Disposed on top end of diagonal support **74** is rigidly mounted pivot box **75** including pivots **76** and **77**. Pivots **76** and **77** pass through pivot box **75** and are rigidly connected thereto.

Referring back to FIG. 7, motorized air walker **900** includes leg members **78** and **79** rotatably supported on an upper end by pivots **77** and **76**, respectively. Foot support base **80** includes pivots **81** and **82** and is rotatably supported

by leg members **78** and **79** thereon such that foot support base **80** remains substantially level during rotation of leg members **78** and **79**. Foot support **83** is disposed on an upper surface of foot support base **80** and retains the patient's foot while in operation (FIGS. 1, 16B, and 17A).

With reference to FIGS. 7, 7A, and 10, motorized air walker **900** includes reciprocator **730**. Reciprocator **730** includes pivot block **86**, adjustment bar **88**, motor **105**, flywheel **91**, and reciprocator frame **90**. Reciprocator frame **90** is generally shown as having a U-shape and is rigidly connected to reciprocator frame base **107**. Reciprocator frame base **107** is rigidly connected to base frame **69**. An upper end of reciprocator frame **90** includes journal bearings **92** and **92'** (FIG. 8) which are mechanically secured thereto via any suitable means known in the art, such as a bolted connection. An axel **89** is rotatably supported by journal bearings **92** and **92'**. Flywheel **91** includes a plurality of gear teeth (not shown) and is disposed within reciprocator frame **90** and is rotatably supported by axel **89**. Adjustment bars **88** and **88'** are disposed on either end of axel **89** and are mechanically secured thereto using any suitable means such as threaded, interference fit, set screw, or the like. Adjustment bars **88** and **88'** are arranged such that each extends in opposite directions (i.e. 180 degrees apart). Disposed on adjustment bars **88** and **88'** are pivot blocks **86** and **86'** respectively. As best illustrated in FIGS. 12A-C, pivot blocks **86** and **86'** are mechanically secured to adjustment bars **88** and **88'** by pivot pins **94** and **94'** to one of a plurality of holes **96** and **96'** defined within adjustment bars **88** and **88'**. Motor **105** includes motor base **106** and is rigidly connected to base frame **69**. Motor **105** may include a speed reduction gearbox. Sprocket **104** is in mechanical cooperation with an output shaft of motor **105**. Sprocket **104** may be affixed to the output shaft of motor **105** by any means known in the art, such as keyway, spline, split collar, or the like. Rotation of sprocket **104** is transmitted to flywheel **91** by drive chain **109**. It is contemplated that drive chain **109** may be replaced by a belt, gear train, direct drive in order to transmit rotation of the output shaft of motor **105** to flywheel **91**.

Leg member **79** includes pivot **85** and control member **84**. Control member **84** is pivotably connected on one end to leg member **79** through pivot **85**. The opposite end of control member **84** is pivotably connected to pivot block **86** through pivot **87** (FIGS. 7 and 12C).

Referring now to FIG. 13, an embodiment of hand supporting tube **97** is shown. Hand supporting tube **97** includes a U-shaped channel **97a** rigidly secured thereto. U-shaped channel **97a** includes a plurality of holes **100** and **99** defined through outer and inner surfaces of each arm of the U-shaped channel **97a**. Hand supporting tube **97** extends from U-shaped channel **97a** at an acute angle so as to form a handle for which the patient may grip during locomotion. Leg member **78** includes a plurality of holes **98** defined therethrough. U-shaped channel **97a** is slideably supported by leg member **78** and may be secured thereto by pins **101** and **102** when disposed within one of plurality of holes **99**, **100**, and **98**. An upper end of hand supporting tube **97** includes hand grip **103**.

Motorized air walker **900** has the capability of stroke adjustment depending upon the needs of each patient. As illustrated in FIGS. 12A-12C, pivot pin **94** includes an elongate body **94b** including threads **94a** disposed on a first end and a boss **94c** disposed on a second end. Threads **94a** are configured to threadably engage knob **94d**, such that a force imparted on knob **94d** translates pivot pin **94** within longitudinal holes **86a**, **86b**, **86c** defined through pivot block

86. Boss 94c is configured to selectively engage one of the plurality of holes 96 of adjustment bar 88. Pivot pin 94 is biased by a spring 95. Spring 95 is coaxially aligned with pivot pin 94 and is disposed within pivot block 86. A pair of washers 95a, 95b is disposed on either end of spring 95, thereby biasing pivot pin 94 in a depressed position, fully engaging pivot pin 94 within one of plurality of holes 96 of adjustment bar 88. Pulling knob 94d, thereby retracting pivot pin 94, allows pivot block 86 to slide along adjustment bar 88 and positioned at a desired one of plurality of holes 96 to set a desired stroke. Calculations may be performed to determine which one of plurality of holes 96 relates to the required length of stroke of foot support 83. A mark may be placed next to the corresponding one of plurality of holes 96 so when an adjustment is made, both sides of motorized air walker 900 can be set to have the same stroke. This marking may also help to avoid any mistakes with the adjustment of the stroke by eliminating the need to count the number of plurality of holes 96 while setting the stroke. Each one of plurality of holes 96 may be marked with different colors to minimize the risk of having a mismatch of stroke during adjustment. When pivot block 86 is adjusted towards axle 89 and pivot pin 94 is mounted in one of the plurality of holes 96 located closest to axle 89, the length of the stroke is at its minimum. Longer strokes may be obtained by sliding pivot block 86 away from axle 89. When pivot pin 94 is disposed within one of plurality of holes 96 located furthest away from axle 89 the length of the stroke is at its maximum. The position of motorized air walker 900 is defined by the position where the stroke/stride adjustment may be easily accessed from the rear by removing panel 1210 (FIG. 24), as will be discussed in further detail below.

Referring back to FIGS. 7A and 13, details of the stroke adjustment for hand supporting tube 97 are illustrated. Hand supporting tube 97 may be adjusted to accommodate varying heights of patients (e.g. adult or child), as well as the needs of each patient relative to the state of their rehabilitation (i.e. shorter strokes or longer strokes). The embodiment disclosed herein is not meant to be limiting. It is contemplated that other means of adjustment of the hand supporting tube may be applied. In the case of a child or a person with a height lower than the average adult, the adjustment of hand supporting tube 97 will need to be done. As illustrated in FIG. 13, the position of hand supporting tube 97 can be adjusted by releasing pins 101 and 102 and sliding hand supporting tube 97 along leg member 78 until two of the plurality of holes 99 and 100 is coaxially aligned with two of the plurality of holes 98. Hand grip 103 is rigidly mounted to hand tube 97 using any suitable means known in the art.

In operation, when pivot blocks 86 and 86' are properly positioned to achieve the same stroke, rotation of the adjustment bars 88 and 88' (FIG. 10) causes rotation of pivot blocks 86 and 86' around axle 89. As pivot block 86 is in mechanical cooperation with control member 84 through rotational support of pivot 87 (FIGS. 7 and 12C), rotation of pivot 87 about axle 89 causes control member 84 to follow the rotation of pivot 87 on one end, while the opposite end reciprocates longitudinally about pivot 85 of leg member 79. The reciprocating motion of pivot 85 causes corresponding oscillating motion of leg member 79 around pivot 76, thereby causing a swinging motion at pivot 82 of foot support base 80. The foregoing motion of pivot 82 causes foot support base 80 with foot support 83 (FIGS. 1, 7, and 7A) to move in a corresponding swinging motion. Movement of foot support 83 towards motor 105 causes leg member 78 to rotate about pivot 77 towards motor 105 by rotational support of pivot 81, and causes hand grip 103 on

hand tube 97 (FIG. 1) to swing away from motor 105 about pivot 77. When the patient's right hand holds grip 103 and the patient's right foot rests on foot support 83 while motor 105 is active, the patient's right hand and right foot are caused to move in opposite directions. This results in a walking-like movement (i.e. locomotion). The same logic applies to the left side of motorized air walker 900 (e.g. when right foot support 83 moves towards motor 105 then left foot support 83' moves away from motor 105, and when right hand grip 103 moves away from motor 105, left hand grip 103' moves towards motor 105).

Referring now to FIGS. 13, 14, and 18, knee guiding mechanism 111 is illustrated. Knee guiding mechanism 111 is generally of a U-shape and includes parallel extending arms 112 and 122. Arms 112, 122 include a plurality of apertures 112a, 122a (FIG. 13), configured to receive pins 117a, 117b, respectively. Knee guiding mechanism 111 includes stiffening members 117 interposed between arms 112 and 122. Stiffening members 117 are configured to receive pins 117a, 117b therethrough, and although generally shown as having a cylindrical shape, it is contemplated that stiffening members 117 may include any suitable shape, such as square, oval, hexagonal, or the like. It is contemplated that stiffening members 117 may be secured to arms 112, 122 by any suitable means, such as a bolted connection, welding, etc. Pins 117a, 117b are configured to be received within one of the plurality of holes 117c, 117d (FIGS. 7A and 13) of leg members 78 and 79 such that knee guiding mechanism 111 is rotatably secured to each of leg members 78 and 79. Arms 112 and 122 are constructed of a suitable material having some flexibility, but retaining enough rigidity to be able to transversely support/guide the patient's knee.

Continuing with FIG. 14, knee guiding mechanism includes knee sliders 120 and 121. Each of knee slider 120 and 121 are configured and/or dimensioned to slide over each of arms 112 and 122 respectively and be retained thereon by any suitable means, such as frictionally, by adhesives, etc. Knee sliders 120 and 121 may be constructed of a material having low friction and elasticity such that knee sliders 120 and 121 may be deformed by the patient's knee thereby causing each of knee sliders 120 and 121 to be in contact with the patient's knee at all times (FIG. 18). Although generally shown as having a circular cross section, it is contemplated that knee sliders 120 and 121 may also include a D-shaped profile such that there is a round profile on each side facing the patient's knee, and a corresponding planar profile opposite thereto. It may be beneficial for the patient to wear sweat pants or other similar garment during operation of the motorized air walker 900 so the fabric from the garment will slide against the rounded surface of each of knee sliders 120 and 121 thereby causing the knee to be in contact with only the inside texture of the garment. This will minimize irritation of skin in the patient's knee area contacting the knee sliders 120 and 121.

As noted in the foregoing, each side of motorized air walker 900 is mirrored about axis "A" (FIG. 2) and therefore the left side of motorized air walker 900 includes the same features as the right.

As illustrated in FIG. 11, motorized air walker 900 may include a monitor 123. Monitor 123 includes a processor (not shown) and memory (not shown). The microprocessor may be any suitable microcontroller, microprocessor, PLD, PLA, or other suitable digital logic. The memory may be volatile, non-volatile, solid state, magnetic, or other suitable storage memory. Monitor 123 may include a touch screen 123a, including dashboard software stored within the

memory, which is executed using the processor and can be used to start and stop motorized air walker **900**, modify the speed of motor **105**, calculate the distance walked, display the time of day, time of session, or display motivational phrases to increase self-esteem, motivation, etc. As can be appreciated, the clinician or patient may name and record sessions on the memory which can then be accessed at a later time to monitor and analyze the patient's rehabilitation progress. It is also contemplated that a plurality of sensors, which are in electrical communication with the processor, may be disposed on adjustment bar **88** and/or pivot block **86** to identify the position of pivot pin **94** and calculate the distance the patient has walked.

FIG. **15** illustrates an embodiment of left hand strap **130**. Hand strap **130** includes loop **125**, sleeve **124**, and fastening strap **126**. Sleeve **124** includes an elongate body **124a** having a closed proximal end and an open distal end defining a cavity therein. The cavity is configured and/or dimensioned to be able to advance over hand grip **103**, **103'**. Loop **125** is mechanically secured to sleeve **124** and is configured and/or dimensioned to articulate from a position normal to elongate body **124a** to parallel thereto in either proximal or distal directions. An end of loop **125** includes fastening strap **126** mechanically secured thereto in a position normal to loop **125**. Fastening strap **126** includes a proximal end including hook/loop patch **127** and a distal end including hook/loop patch **128**. Patches **127** and **128** are configured such that each may be selectively secured to each other. Hook/loop patch **128** may include loops, and may be on the side of fastening strap **126** where a patient's hand **129** may come into contact therewith. Hook/loop patch **127** may include hooks and may be on the opposite side of fastening strap **126** such that a patient's hand **129** may not come into contact therewith.

In operation, when sleeve **124** is advanced over grip **103'**, a patient may then place their hand **129** on fastening strap **126** on the side which contains hook/loop patch **128**, including loops. The patient or clinician may then wrap fastening strap **126** around their hand and/or wrist **129** such that hook/loop patch **127**, including hooks, is on top of the patient's hand **129** such that the hook/loop patch **127** does not directly touch the patient's skin. At this point, the end of strap **126** including hook/loop patch **128** is wrapped around the patient's hand **129** such that hook/loop patch **128** engages hook/loop patch **127**, thereby securing the patient's hand therein. In this manner, as best illustrated in FIGS. **1**, **1A**, and **2**, the orientation of sleeve **124** with respect to the patient's hand **129** is such that the patient may easily grasp grip **103'**, since the joint between hook/loop patches **127** and **128** is located outside of the patient's hand **129**, thereby inhibiting interference with the patient's grasp of grip **103'**. A similar operation as described in the foregoing may be performed for the patient's right hand with strap **126'** (FIG. **1**).

Referring now to FIGS. **16A** and **16B**, an embodiment of foot strap **131** is illustrated. Foot strap **131** includes lower strap **133** including proximal and distal ends. The proximal end of foot strap **131** includes a hook/loop patch **134**, and the distal end includes a hook/loop patch **135**. Additionally, the distal end of foot strap **131** includes a hook/loop patch **136** disposed proximally of hook/loop patch **134** and the same side of lower strap **133** as hook/loop patch **135**. Furthermore, the proximal end of foot strap **133** includes a hook/loop patch **138** disposed distally from hook/loop patch **134**, but on the opposite side of lower strap **133**. Foot strap **131** includes heel strap **132** having proximal and distal ends rigidly connected thereto and is configured and/or dimen-

sioned to accept a patient's heel. Foot strap **131** is mechanically secured to foot support **83'** such that, in operation, foot strap **131** retains the patient's foot **137** within foot support **83'**.

In operation, a patient may secure their foot **137** using foot strap **131** while standing on foot support **83'**. A patient or clinician may place the patient's foot **137** over foot strap **133** until heel strap **132** rests on the patient's heel (FIG. **16A**). The clinician or patient may then pull and flip over the end of foot strap **133** that includes hook/loop patch **138** towards the patient's toes such that hook/loop patch **138** is facing upward as illustrated in FIGS. **17A** and **17B**. The patient may then lock the proximal end of lower strap **133** using hook/loop patch **134** and hook/loop patch **139a** disposed on a side of foot rest **83'**, as illustrated in FIG. **17B**. The patient may next flip over the distal end of lower strap **133** such that hook/loop patch **136** locks with hook/loop patch **138**, and thereafter, the distal end of lower strap **133** can be locked using hook/loop patch **135** and a hook/loop patch **139b** disposed on an opposing end of foot rest **83'** than hook/loop patch **139a**, as illustrated in FIG. **17A**. At this point, a cross strap **132a** (FIG. **16A**), with a distal end rigidly secured to an inside portion of heel strap **132**, is pulled over the patient's foot **137** and locked to the outside portion of heel strap **132** using a hook/loop patch **132b** disposed on cross strap **132a** and a hook/loop patch **132c** disposed on heel strap **132**.

It is contemplated that the foot strap **131** and hand strap **130** may be optional and should be used on an as needed basis as determined by the clinician. Each of foot strap **131** and hand strap **130** provide enough strength that each will secure the patient's hands and legs while operating the motorized air walker **900**, while being flexible enough that the patient's heel may be lifted during operation of motorized air walker **900**. It is also contemplated that if a patient so chooses, he/she can hold grip **103**, **103'** and operate motorized air walker **900** without any restrictions from hand strap **130** or foot strap **131**.

FIGS. **18**, **19**, **20**, and **20A** illustrate the operation of harness **800**, which can be used with or without a feed tube **251** (gastric tube) and/or a breathing tube **250**, or any combination thereof. Strap **201** is disposed on a right side of a patient and includes a female buckle **214a** disposed on a first end and a male buckle **202a** disposed on a second, opposing end. Strap **201** is configured to be received within strap hanger **216**. Strap hanger **216** is configured to be selectively attached to hook **59** of suspension system **710** using any suitable latching device **216e**, as discussed in detail hereinabove. Strap **201** is oriented such that female buckle **214a** is disposed on the backside of the patient, whereas male buckle **202a** is disposed on the front side of the patient. Harness **800** includes a second strap **200** disposed on a left side of the patient. Strap **200** includes similar components and is utilized in a similar fashion to strap **201**, and therefore, in the interest of brevity, details of strap **200** will not be discussed in detail herein.

As best illustrated in FIG. **20**, harness **800** includes cage **223**. Cage **223** includes a pair of horizontal arcuate bars **203** and **206** disposed in a stacked orientation. Cage supports **223a** are interposed between arcuate bars **203** and **206** on either side, thereby forming a hoop configuration. Cage supports **223a** may be secured to arcuate bars **203**, **206** by any suitable means, such as welding, adhesives, or bolted connection. Pins **223b** are disposed at a rearward position on an outer surface of arcuate bars **203**, **206** and extend outwardly therefrom. Pins **223b** are disposed on both sides of arcuate bars **203**, **206** and are configured to be received

within a plurality of apertures **241** defined in opposing sides of back support **240**. Cage **223** includes a resilient coating **223c** disposed on arcuate bars **203**, **206**. Resilient coating **223c** may be any suitable resilient material, such as foam. A pair of Y-shaped straps **225** is rigidly secured to the front side of the resilient coating **223c** of cage **223**. Each of the pair of Y-shaped straps includes identical components, and therefore, in the interest of brevity, only one Y-shaped strap **225** will be described herein. An upper end of Y-shaped strap **225** includes a female buckle **202b**, corresponding to male buckle **202a**. The lower end of Y-shaped strap **225** includes a pair of female buckles **205a**, **207a**. It is contemplated that back support **240** may include a suitable resilient material **240b** disposed thereon, such as foam, in order to minimize patient discomfort. Back support **240** provides a benefit in that back support **240** provides support for head frame **240a**, thereby providing support for the patient's head (FIG. **18B**) during the operation of machine **600**. A further benefit is that cage **223** creates a pressure free zone over the patient's abdominal area, thereby inhibiting the application of any stress to feed tube **251** (discussed below).

Leg harness **800b** includes a pair of leg cuffs **209**. Each of leg cuffs **209** is identical, and therefore, in the interest of brevity, only one leg cuff **209** will be discussed in detail herein. Leg cuff **209** includes a leg pad **209a**. Although generally shown as having a rectangular shape, leg pad **209a** may include any suitable shape such as oval or the like. Leg pad **209a** is constructed of a suitable resilient material, such as foam, in order to minimize patient discomfort. Leg cuff **209** includes a pair of leg pad straps **209b** attached thereto at one location such first and second ends of leg pad straps **209b** can move independently of leg pad **209a**, but cannot become unattached therefrom. Leg pad straps **209b** include a female buckle **209c** disposed on a first end and a corresponding male buckle **209d** disposed on second end (FIGS. **19** and **20A**). Leg pad straps **209b** operate to maintain leg pad **209a** in a rolled orientation around the patient's leg, thereby preventing the patient's leg from becoming removed from leg harness **800b**. Leg harness **800b** includes a rear strap **219** rigidly secured to at least one, as shown two, of leg pad straps **209b**. A first end of rear strap **219** is rigidly secured to leg pad strap **209b** at a location at the rear of leg cuff **209** and extends vertically therefrom. A male buckle **214b** is disposed on a second end of rear strap **219** corresponding to female buckle **214a**. A front end of the leg pad strap **209a** that includes rear strap **219** includes a front strap **207** rigidly secured thereto on a first end and extending vertically therefrom. Front strap **207** includes a male buckle **207b** disposed on an end thereof corresponding to female buckle **207a** on Y-shaped strap **225**. An intermediate strap **205** is rigidly secured to leg strap **209b** at a similar location to that of rear strap **219**. Intermediate strap **205** extends vertically towards the front of leg harness **800b** and includes a male buckle **205b** disposed on opposite end thereof corresponding to female buckle **205a** of Y-shaped strap **225**. It is contemplated that any strap utilized in harness **800** may be adjustable, thereby permitting the clinician to easily adjust harness **800** to an individual patient. Each of leg cuffs **209** is secured to each other using lateral strap **252**, which is interposed between rear strap **219** and rigidly secured thereto at the joint formed by rear strap **219** and leg pad strap **209b**. Lateral strap **252** is formed from a suitable resilient material, such as rubber, elastic, or the like, and in operation, inhibits each leg cuff **209** from rotating around the leg while operating due to rotational tension created by strap **205**. The tension of lateral strap **252** can be regulated by buckle **252a**,

which may be any suitable buckle capable of adjusting and maintaining tension in lateral strap **252** (FIG. **20**).

With reference to FIGS. **18-18B**, an illustration of head harness **800c** is provided. Head harness **800c** includes upper strap **227**, lower strap **228**, lateral strap **229** and vertical straps **230**. Upper and lower straps **227**, **228** are oriented in a parallel configuration and each terminates in a male connector **231** on each end. Male connector **231** may be any suitable connector capable of selectively engaging a corresponding female connector **232** and providing adjustment of upper and lower straps **227**, **228**. Lateral strap **229** is rigidly secured to upper strap **227** on a first end and includes a hook/loop patch **229a** disposed thereon on a second end. Hook/loop patch **229a** is configured and/or adapted to engage a corresponding hook/loop patch **227a** disposed on an opposite side of upper strap **227**, thereby preventing head harness **800c** from sliding in a caudal direction by contacting the crown of the patient's head. Vertical straps **230** are rigidly secured to upper and lower straps **227**, **228** on each end and are disposed on opposing sides thereof, as best illustrated in FIG. **18B**. Female connectors **232** are disposed on each corner of headboard **240a**, which extends in a cephalad direction from back support **240**. Headboard **240a** includes a suitable resilient material disposed thereon, such as foam, in order to minimize patient discomfort. In operation, upper and lower straps **227**, **228** are adjusted to accommodate the patient's head. Thereafter, head harness **800c** may be advanced over the patient's face such that upper strap **227** is disposed over the patient's forehead, whereas lower strap **228** is disposed above the patient's mouth but below the patient's nose. At this point, each of male connectors **231** are inserted within female connectors **232**, thereby securing head harness, and thereby the patient's head, to headboard **240a**. Next, lateral strap **229** is pulled over the crown of the patient's head and secured to upper strap **227** by means of hook/loop patches **227a**, **229a**. At this point, each of upper and lower straps **227**, **228** may be further adjusted for comfort.

Each strap and buckle used in harness **800** may be any suitable strap and buckle known in the art. In one embodiment, the strap and buckles used in harness **800** are a common automotive type (i.e., a seatbelt). It is further contemplated that each corresponding male and female buckle may be color coordinated (i.e., male buckle **205b** and female buckle **205a** can be red, male buckle **207b** and female buckle **207a** can be blue, etc.) This configuration aids the clinician in matching up each of the buckles to enable the clinician to quickly and easily strap the patient into harness **800**.

In operation, a patient may be transferred to the bed lifter **700** in one room and transported to a separate room where motorized air walker **900** is located. Conversely, the motorized air walker **900** may be transported to the room where the bed lifter **700** is located. It is contemplated that machine **600** may be placed in a patient's household, a clinical setting, a hospital setting, or the like.

Initially, as best illustrated in FIG. **21**, a patient is in a supine position on bed **47** of bed lifter **700** such that the patient's head is adjacent to arm **15** of wagon **16**. It is contemplated that the patient may be prepared with a feed tube **251** and/or a breathing tube **250** before proceeding to the next steps, or during the procedure, as needed. The clinician may next transport the patient and bed lifter **700** to motorized air walker **900**, or conversely, the motorized air walker **900** may be transported to the patient and bed lifter **700** such that the motorized air walker **900** is adjacent to the patient's feet. The clinician may next secure harness **800**

17

around the patient's torso, and thereafter adjust harness **800** to accommodate the height of the patient. Once harness **800** has been adjusted, the clinician may secure harness **800** to suspension system **710**. At this point, the head harness **800c** may be secured to the patient's head to support the head before articulating the bed lifter **700** to an inclined position. The clinician may next articulate bed lifter **700** to an inclined position, thereby permitting harness **800** and suspension system **710** to bear the patient's weight and support the patient in a vertical orientation (FIG. 1). Thereafter, the patient may be placed on motorized air walker **900**. Depending on the condition of the patient, the clinician may secure the patient to motorized air walker **900** utilizing foot straps **131** and hand straps **130**. Once placed on and/or secured to motorized air walker **900**, the clinician may adjust motorized air walker **900** to accommodate the height and/or gait of the patient as described in detail hereinabove. The clinician may next operate motorized air walker **900** by utilizing motor **105** to effectuate locomotion, or by allowing the patient to effectuate locomotion utilizing foot supports **83** and **83'**, and hand grips **103** and **103'**. It is contemplated that in the case of a power failure and a failure of the back-up battery system **1000** (described in detail below), bed lifter **700** may be actuated manually using a suitable winch or crank mechanism (not shown). In this manner, the clinician will be able to easily remove the patient from the machine **600** without the assistance of electrical power.

FIG. 22 illustrates an electrical schematic of a battery back-up system, generally referred to as **1000**. Battery back-up system **1000** includes back-up battery **235**, main power supply **236**, a plurality of rocker switches **230**, **231** and a plurality of actuators **37** and **22**. During normal operation the actuator **37** is controlled by rocker switch **231**, wherein rocker switch **231** controls the power from power supply **236**, including a diode **233**. In the case where a patient is in an upright position and a power failure occurs, the back-up battery **235** is activated automatically to provide power to rocker **231** through diode **234** in order to power the bed lifter **700** and return the patient to a horizontal position. The same logic applies to actuator **22** and rocker switch **230**.

It is contemplated that the plurality of rocker switches **230** and **231** may be replaced by monitor **123** (FIG. 11) and a motion control system such that telescoping actuator **22** and actuator **37** may be controlled therefrom.

With reference to FIG. 23, it is contemplated that frame **14** of bed lifter **700** may be enclosed via a plurality of panels **1100**. Each of panels **1100** may be constructed of any rigid material suitable for use in a clinical setting, such as stainless steel, polypropylene, or the like. Similarly, as illustrated in FIG. 24, reciprocator **730** of motorized air walker **900** may be enclosed via a plurality of panels **1200**, thereby preventing injury from contact with the moving parts of reciprocator **730**.

It will be understood that various modifications may be made to the embodiments of the presently disclosed screw insertion instrument. Therefore, the above description should not be construed as limiting, but merely as exemplifications of embodiments. Those skilled in the art will envision other modifications within the scope and spirit of the present disclosure.

What is claimed is:

1. A system for patient rehabilitation, comprising:
an articulating bed including a first and second end, wherein the bed is rotatably supported by a first movable frame at a first end, wherein the bed is configured to be selectively articulated to an inclined position; and

18

a suspension system defining a frame that is translatably supported by, and movable with, the articulating bed, the frame defining proximal and distal portions, the proximal portion of the frame defining an arm extending therefrom, wherein the frame is selectively adjustable along a longitudinal axis defined between the first and second ends of the articulating bed, wherein the frame includes a plurality of wheels rotatably disposed thereon, the plurality of wheels configured to translatably support the frame within the articulating bed.

2. The system according to claim 1, wherein the plurality of wheels defines a first plurality of wheels configured to translatably support the frame in a first direction.

3. The system according for claim 2, wherein the plurality of wheels defines a second plurality of wheels configured to translatably support the frame in a second direction, the second direction being perpendicular to the first direction.

4. The system according to claim 1, further comprising:
a harness, including a plurality of straps for securing the torso, legs, head, hands, arms, and feet of a patient, wherein at least one of the plurality of straps is selectively engageable with the suspension system of the articulating bed, wherein at least one of the plurality of straps is selectively adjustable to accommodate a variety of patient sizes.

5. A system for patient rehabilitation, comprising:
an articulating bed including a first and second end, wherein the bed is rotatably supported by a first movable frame at a first end, wherein the bed is configured to be selectively articulated to an inclined position;

a suspension system defining a frame that is translatably supported by, and movable with, the articulating bed, the frame defining proximal and distal portions, the proximal portion of the frame defining an arm extending therefrom, wherein the frame is selectively adjustable along a longitudinal axis defined between the first and second ends of the articulating bed; and

an actuator, wherein the actuator is operably connected to a portion of the articulating bed and a portion of the frame of the suspension system, wherein actuation of the actuator translates the frame of the suspension system relative to the articulating bed.

6. The system according to claim 5, wherein the actuator is selected from the group consisting of hydraulic actuator, a pneumatic actuator, and an electric actuator.

7. The system according to claim 5, wherein the actuator is capable of translating the frame relative to the articulating bed independent of the orientation of the articulating bed.

8. A system for patient rehabilitation, comprising:
an articulating bed including a first and second end, wherein the bed is rotatably supported by a first movable frame at a first end, wherein the bed is configured to be selectively articulated to an inclined position;

a suspension system defining a frame that is translatably supported by, and movable with, the articulating bed, the frame defining proximal and distal portions, the proximal portion of the frame defining an arm extending therefrom, wherein the frame is selectively adjustable along a longitudinal axis defined between the first and second ends of the articulating bed; and

a walker, including:

a second movable frame;

a pair of legs including an upper and lower end, wherein each of the pair of legs is rotatably supported by the second movable frame, wherein each of the pair of legs includes a foot support on the

lower end thereof, wherein each of the pair of legs includes a gripping portion for a patient's hand on the upper end thereof.

9. The system according to claim 8, wherein the walker further includes a reciprocator, including:

a motor, wherein the motor is rigidly secured to the second movable frame, wherein the motor includes a sprocket, wherein the sprocket is in mechanical cooperation with the motor;

a reciprocator frame, wherein the reciprocator frame is rigidly secured to the second movable frame.

10. The system according to claim 9, wherein the walker further includes a flywheel rotatably supported by the reciprocator frame, wherein the flywheel is in operative communication with the sprocket, wherein the flywheel is in operative communication with at least one of the pair of legs.

* * * * *