

End-to-End SpechtLab Smart Ecosystem

Master Document for System Integrators:
Product Catalog and L2/MES Integration Guide

SpechtLab



Designing the Blueprint for 100% Quality Control

The Anatomy of an Intelligent Line

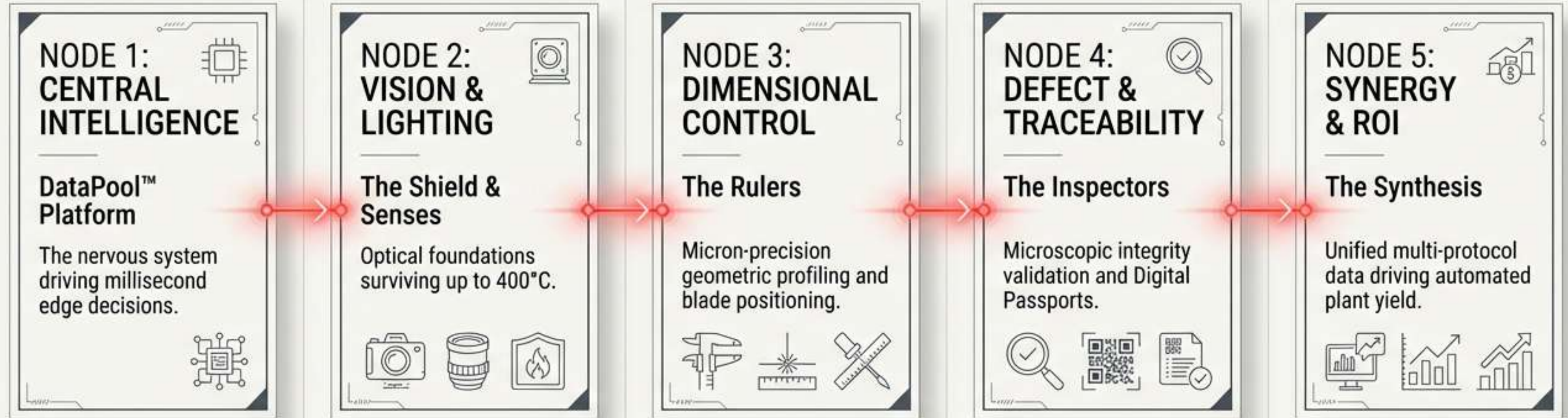

SECTION 1: CENTRAL INTELLIGENCE

DataPool™ Architecture: The Central Nervous System

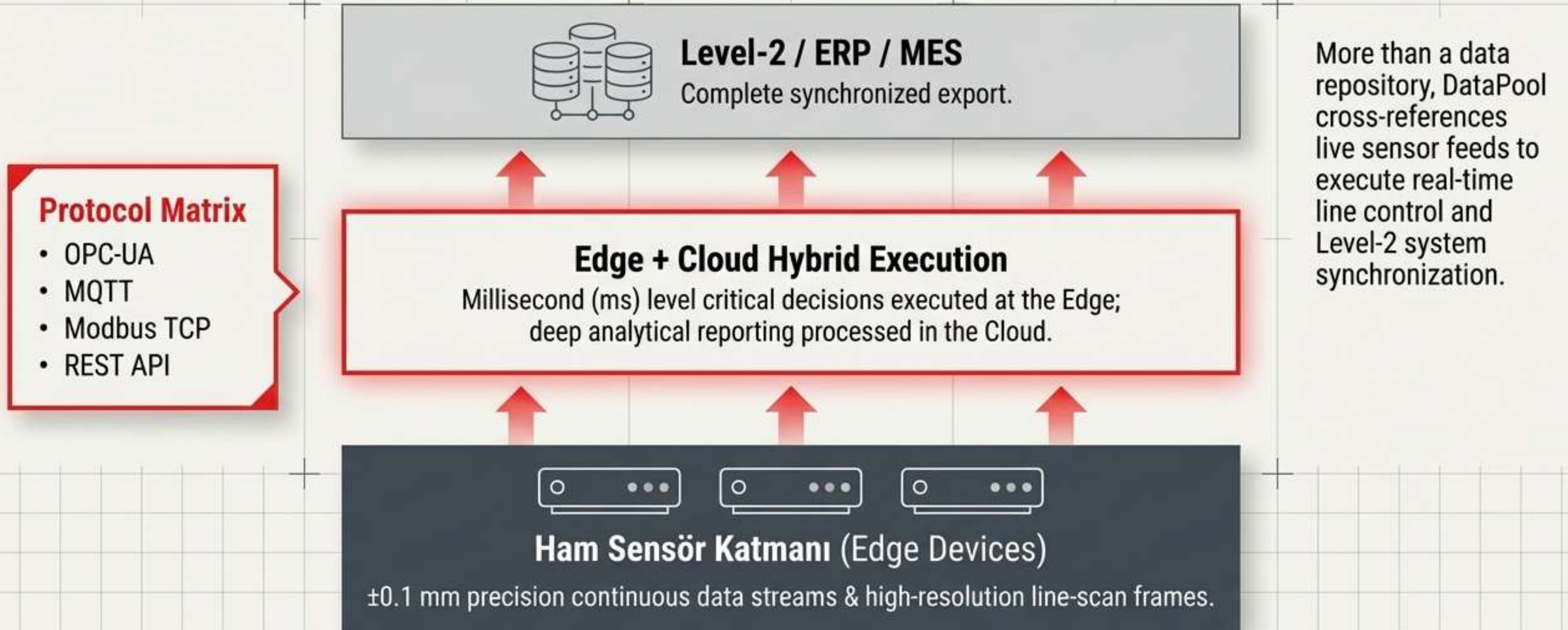

Advanced AI & Dynamic Recipe Management

AI Anomaly Detection

Deploys latest machine learning algorithms to **detect invisible trend deviations**. Triggers automatic, proactive alerts to operators and maintenance teams before tolerance limits are breached.



Dynamic Recipe Control

Automatically assigns specific tolerances, line speed, and active blade offsets based on the incoming physical product identity (Roll No).

Digital Product Passport

Creates a fully exportable, comprehensive quality history for every single manufactured roll, securely binding microscopic inspection data to physical identity.

SECTION 2: VISION & LIGHTING

LC Series Cooling Housings: Shielding Critical Sensors

Uninterrupted optical measurement in steel, glass, and cement plants without halting production.
Protects delicate electronics in extreme environments.

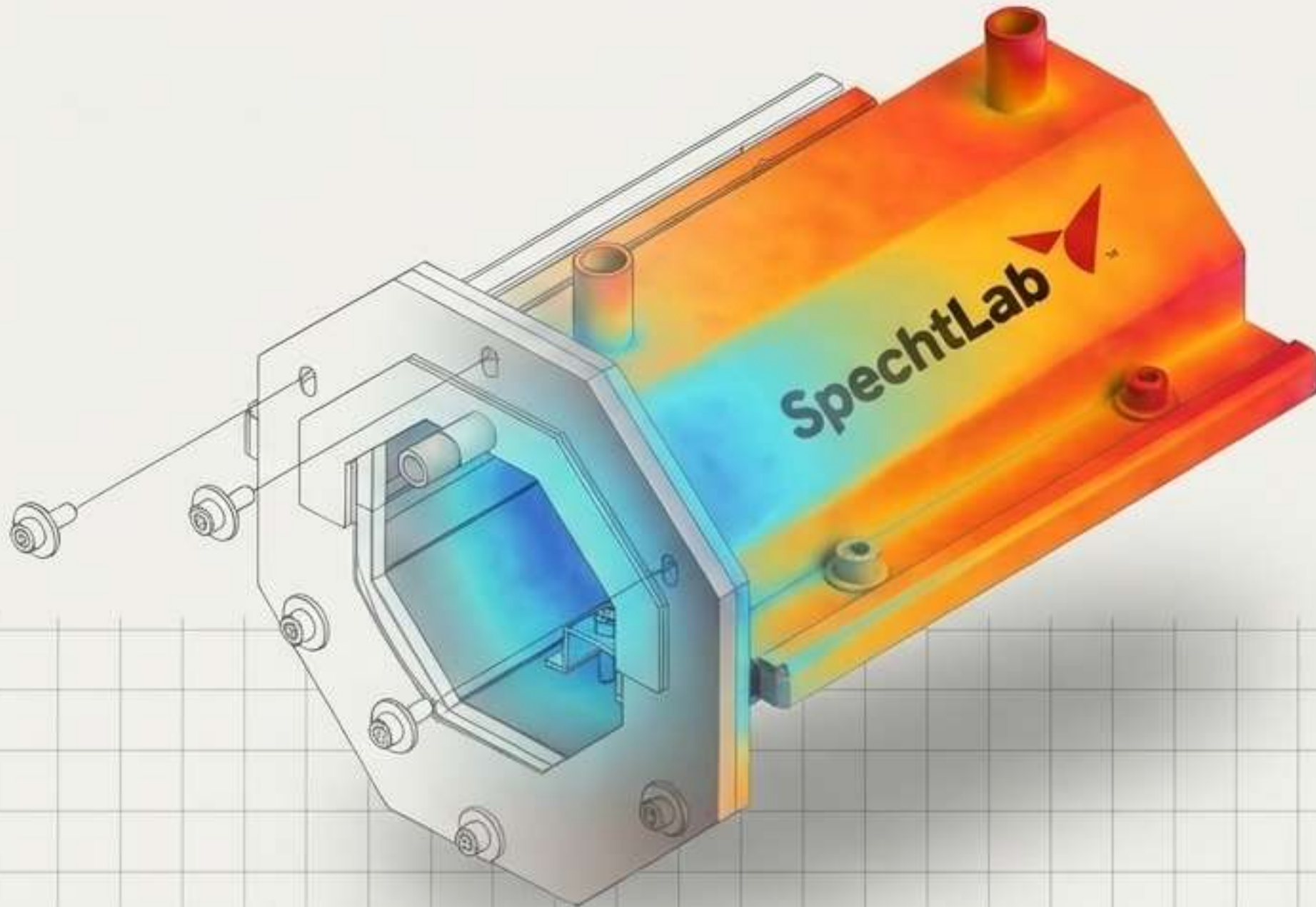

Ambient Survival Temp	Up to 400°C
Cooling Medium	Industrial Water or Nitrogen Gas
Water Pressure	Max 4 bar
Flow Rates	10 lt/min at 25°C 20 lt/min at 35°C
Power Connectivity	220V / 24V / PoE
Protection Rating	IP65

BL Series Stroboscopic LED: Eradicating Motion Blur

Standard continuous lighting causes motion blur at line speeds of 100–600 m/min. The BL Series uses modulated high-power flashes to perfectly freeze high-speed periodic defects.

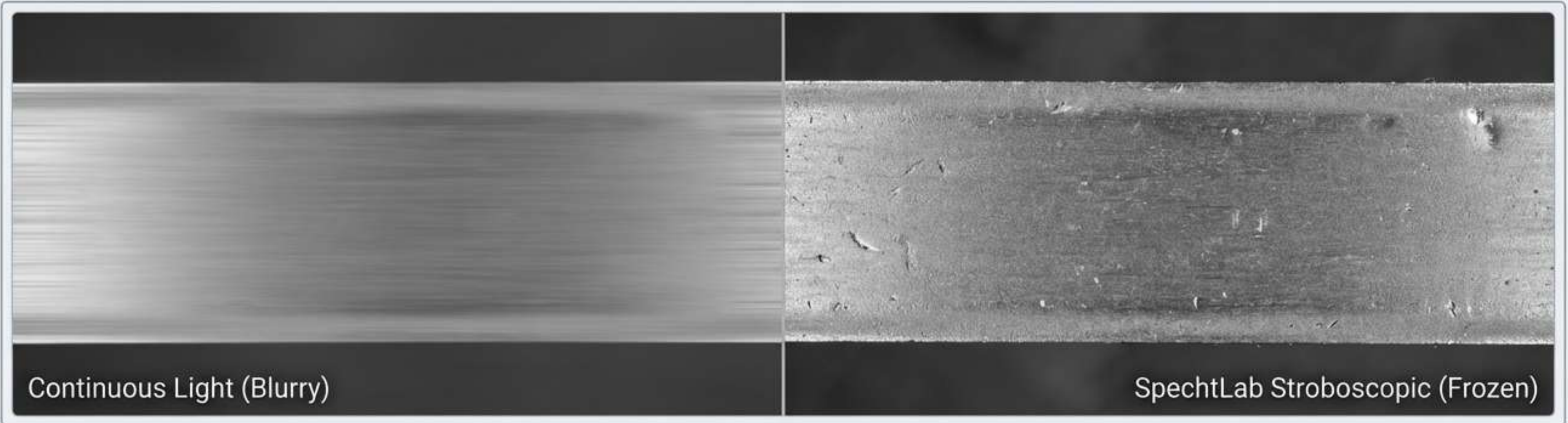

Performance Specs

- **Synchronization:** 20–10k Hz encoder sync with nanosecond camera precision.
- **Flash Duration:** 1–5 μ s adjustable pulse.
- **Line Speed:** Freezes motion at speeds up to 600 m/min.
- **Precision:** Physical movement is less than 0.01mm per captured frame.

SECTION 3: DIMENSIONAL CONTROL

WG Series: Micron-Precision Width Measurement

Continuous, non-contact stereoscopic width measurement designed to entirely eliminate false readings caused by material bounce, vibration, or thickness variations.

Architecture Details

- **Illumination:** Adapts to both Backlight and Frontlight configurations.
- **Precision:** ± 0.1 mm typical accuracy.
- **Integration:** Direct algorithm export to PLC, SAP, and Level-2 systems via standard Ethernet/RS485 networks.

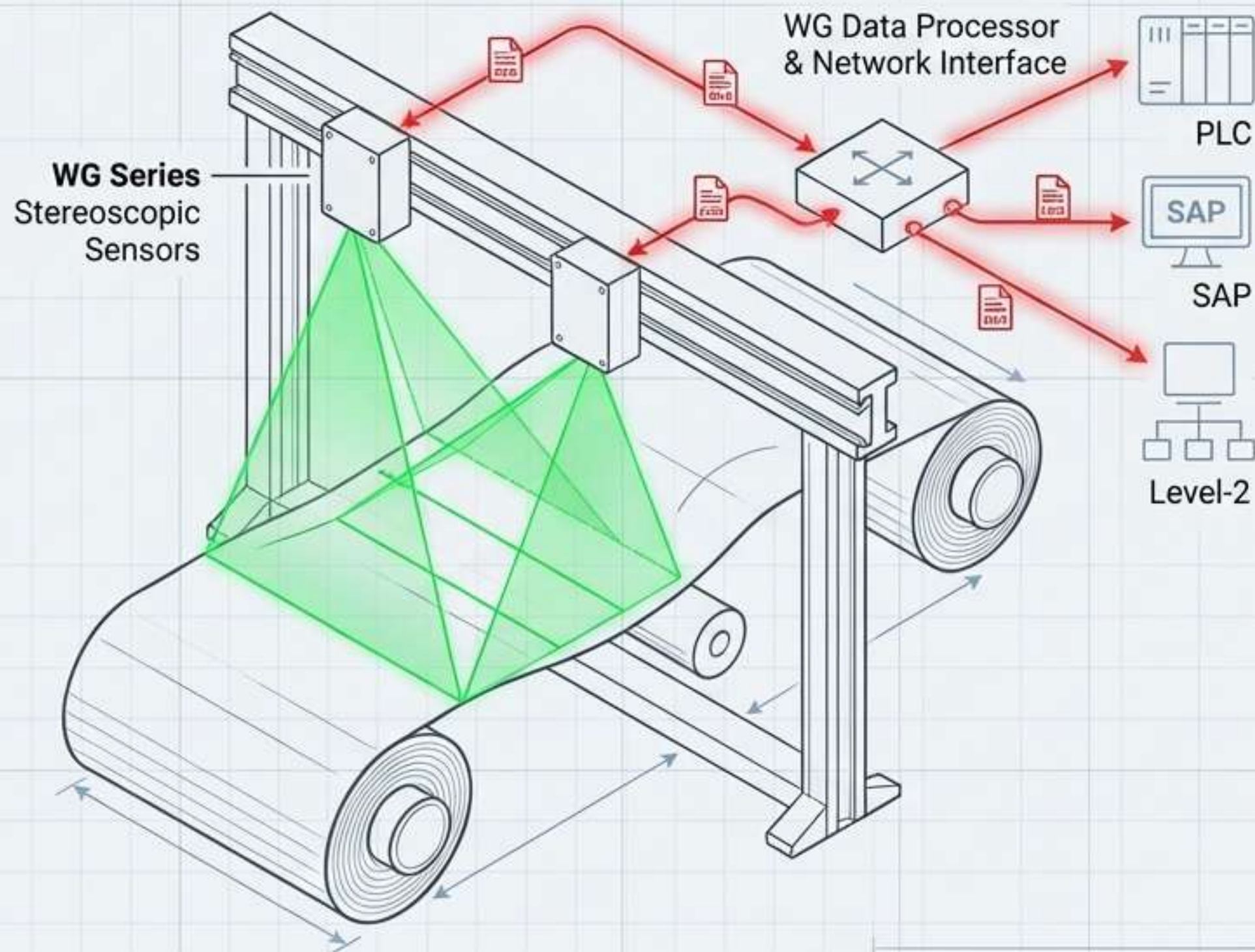

PM Series: Real-Time 2D/3D Topographical Profiling

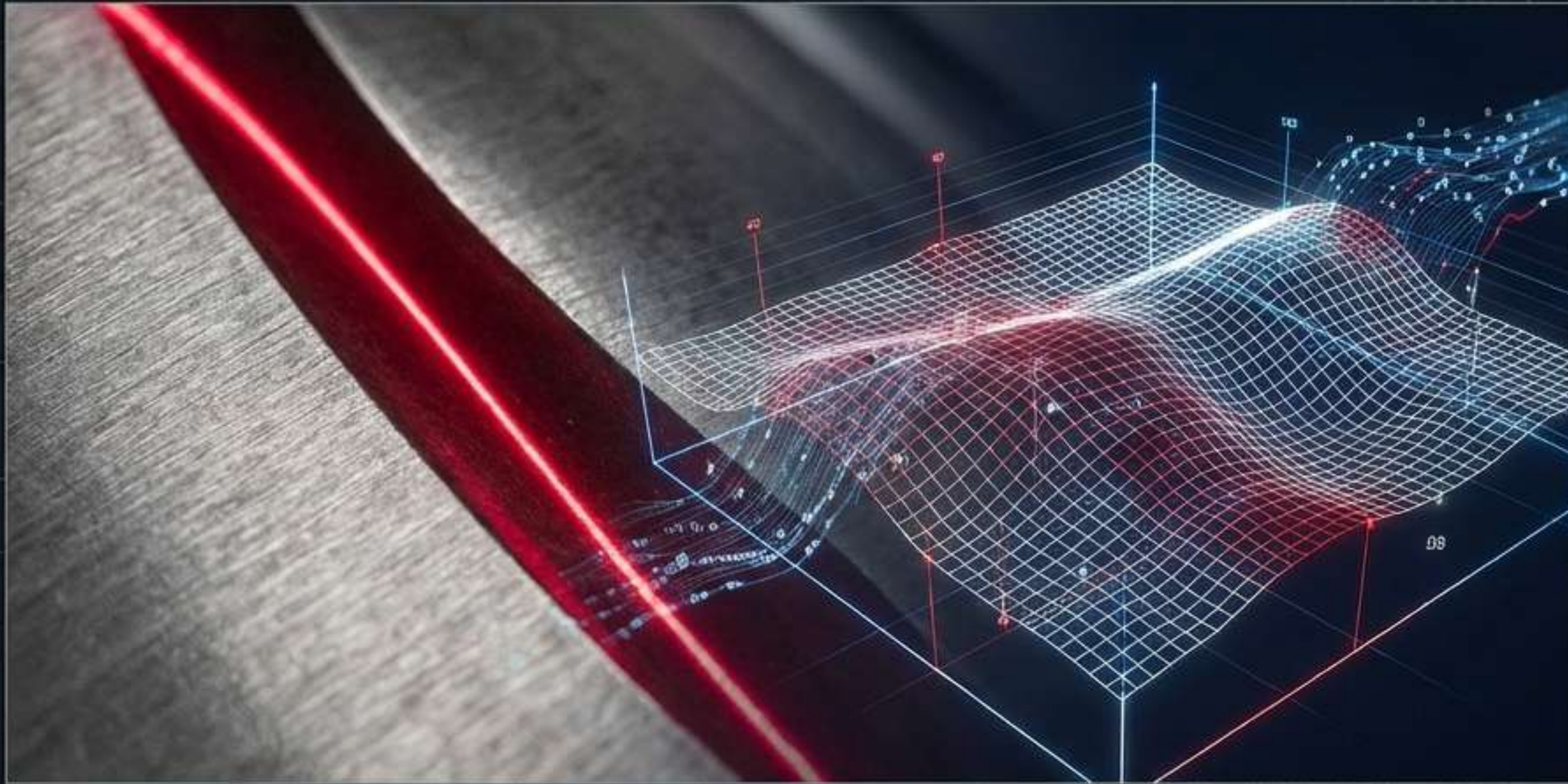

Core Concept

Utilizing advanced laser triangulation, the PM Series generates high-resolution 3D thickness profiles to instantly identify geometric structural flaws such as crown, wedge, and edge drop.

Hardware Profile

- **Protection:** Lightweight, IP65-rated industrial housing.
- **Application:** In-line guidance, identification, and absolute contour verification across steel, semiconductor, and automotive networks.

EdgeCut Vision System: Automated Side Trimmer Control

Analyzes edge texture and micro-rupture density in real-time. Acts as an early warning mechanism for blade wear and controls automated blade positioning to drastically reduce physical scrap rates.

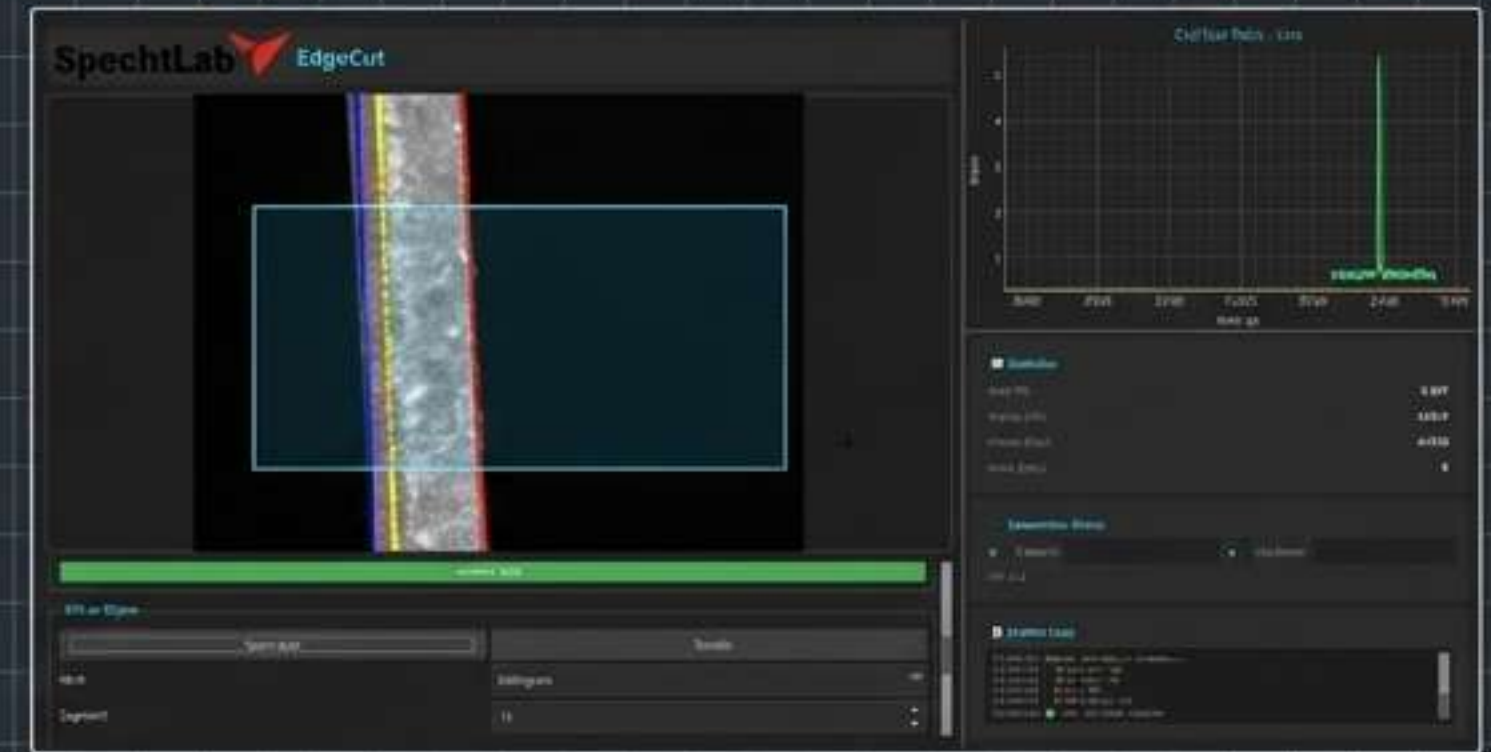

EdgeCut UI: Live Edge Tear Analysis

Specification Matrix

- Field of View (FOV): 30–80 mm
- Spatial Resolution: 10–30 μm / pixel
- Measurement Accuracy: ± 0.05 mm (typical)
- Sampling Frequency: 1–10 kHz
- Algorithmic Delay: <10 ms

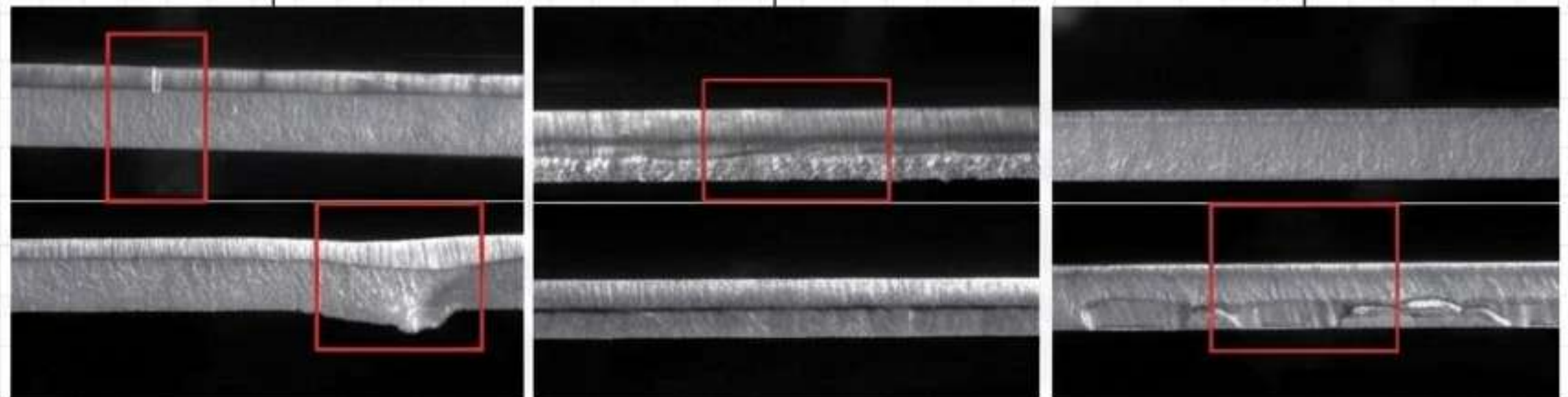

Microscopic Edge Analysis & Defect Detection (Superimposed Bounding Boxes)

SECTION 4: DEFECT & TRACEABILITY

Pinhole Detection: Guaranteeing Absolute Material Integrity

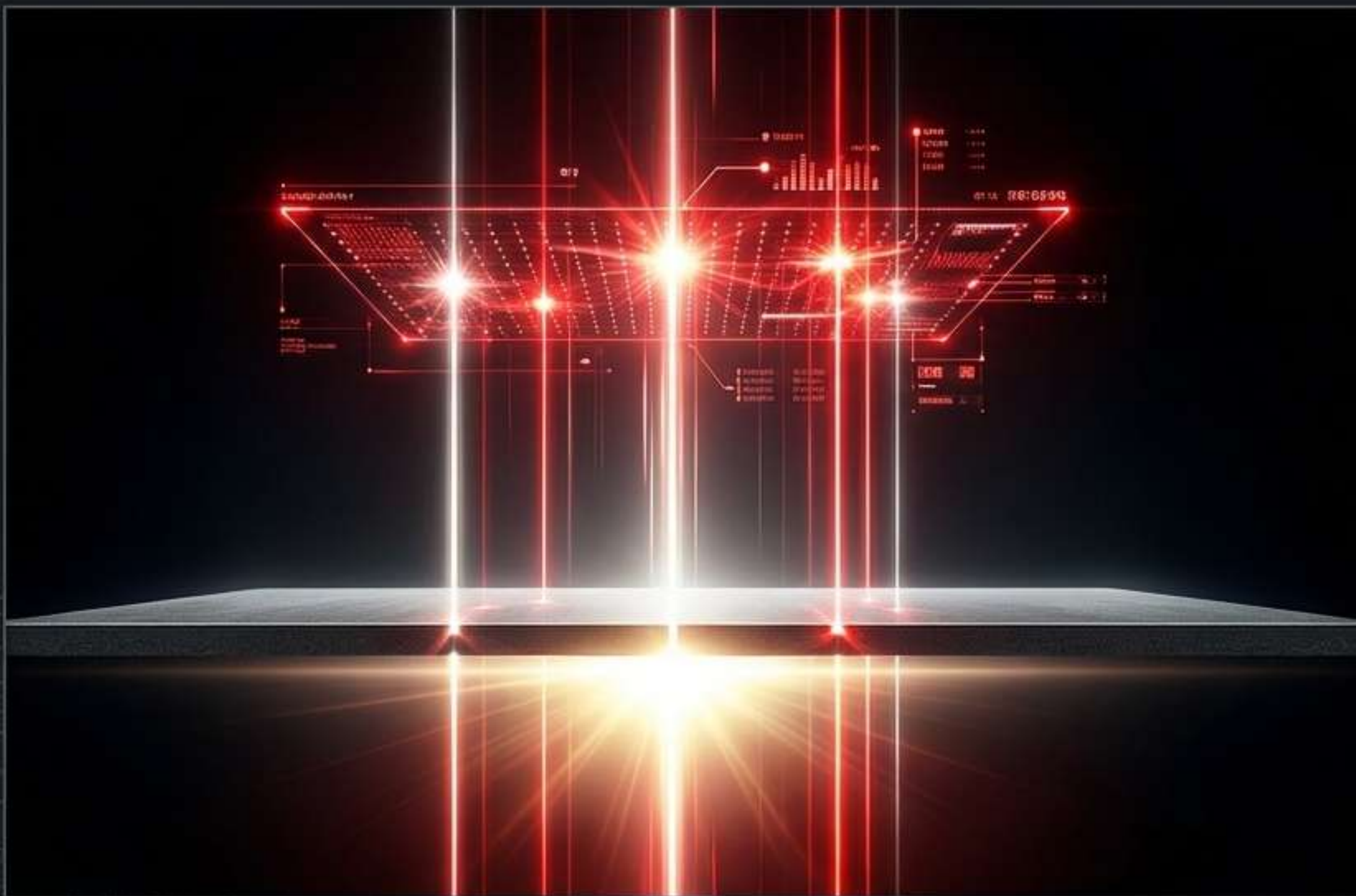

Core Concept

The ultimate end-of-line fail-safe. Captures microscopic light leaks to guarantee 100% material and packaging integrity before shipment.

Functional Role

Operates as the final gatekeeper, ensuring that zero compromised material progresses to the coil stage, permanently logging micro-failures to the specific product batch.

Industrial OCR: Triggering the Digital Passport



The Integration Trigger: Deployed in the harshest environments, the OCR instantly reads roll and product codes on the fly. Once read, it binds the physical product identity directly to the DataPool. This single action initializes the unique Digital Product Passport, matching all subsequent downstream sensor data to this specific roll.

SECTION 5: SYNERGY & ROI

The SpechtLab Integration Matrix

Hardware Module	Primary Function	Output Data Type	Latency / Speed	DataPool Interaction
LC Cooling	Thermal Shielding	Environmental Status	Continuous	Logs Temp to Passport
BL Strobe	Motion Freezing	Optical Trigger	1-5 μ s pulse	Synchronizes Camera Array
WG Width	Stereoscopic Geometry	1D Array / mm Value	Real-time	Verifies Recipe Tolerances
PM Profiler	3D Topography	3D Point Cloud	Real-time	Triggers Geometric Alerts
EdgeCut	Side Trimmer Control	Blade Offset Coordinates	<10 ms	Adjusts Automated Blades
Pinhole	Integrity Fail-safe	Boolean Pass/Fail	Real-time	Appends Defect to Passport
OCR	Character Recognition	Alphanumeric String	Instant	Fetches Dynamic Recipe

The Ecosystem in Action: Anatomy of an Intelligent Line

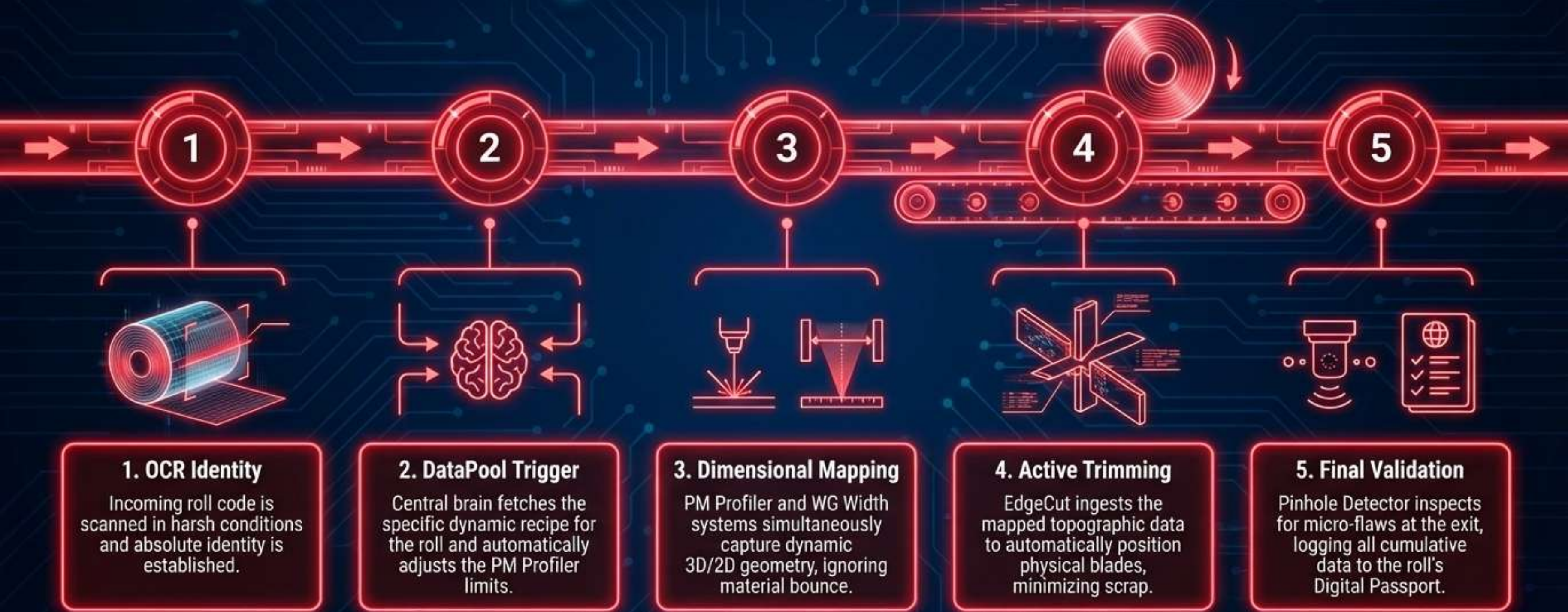

Transforming Synergy into Operational ROI



SCRAP

Scrap Rate Reduction

EdgeCut automated blade positioning combined with PM 3D profiling drastically reduces physical edge waste and irregular cuts.



LIFESPAN

Equipment Lifespan

Data-driven optical analysis of blade sharpness and micro-ruptures extends tool life and entirely eliminates unplanned mechanical downtime.



UPTIME

Predictive Uptime

DataPool's AI anomaly detection transforms reactive, emergency repairs into scheduled, predictable maintenance routines.



Manufacturing is Blind & it's Costing Billions



You take control of processes you cannot control.

Industry 4.0 demands more than isolated sensors; it requires a unified nervous system. SpechtLab removes the blindspots, turning raw manufacturing environments into predictable, hyper-efficient digital ecosystems.

Partner with us to build the connected line.
info@spechtlab.com | +90 506 884 01 56