

MINGDA

MD-1000D Ultra

Print Bigger • Print Faster • Print Smarter



All-New Upgrade Highlights

Performance Redefined

**Lighter.
Stronger. Smarter.**

All-New Extruder



**Premium Print
Quality Upgrade**



Z-Offset Auto Calibration



Smart Dual-Nozzle Alignment

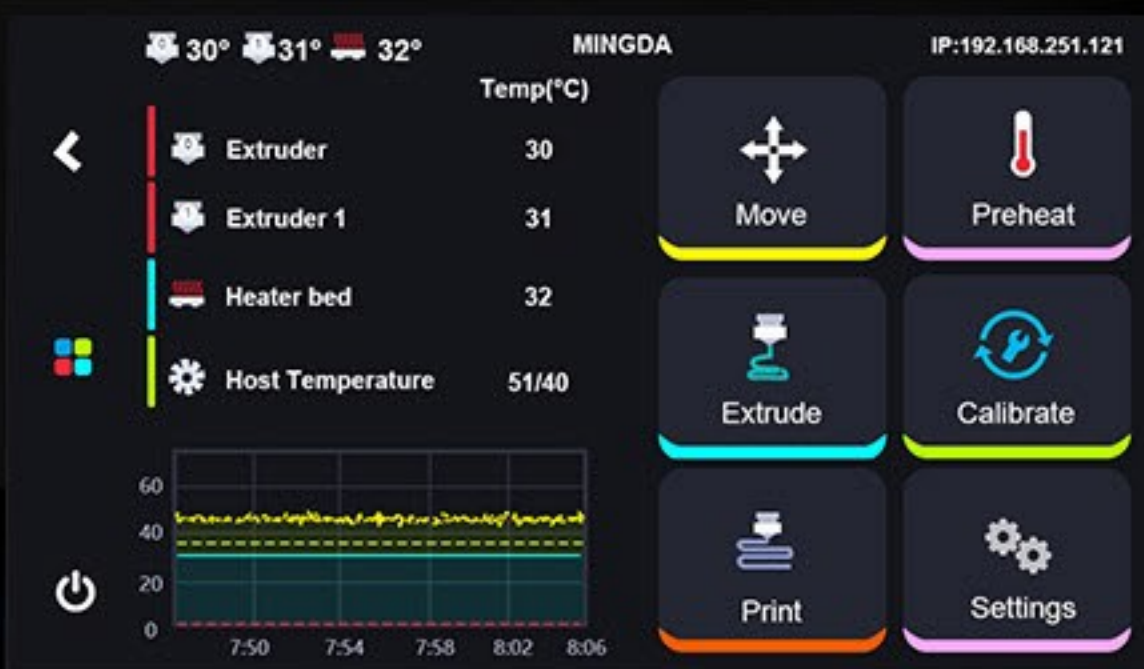
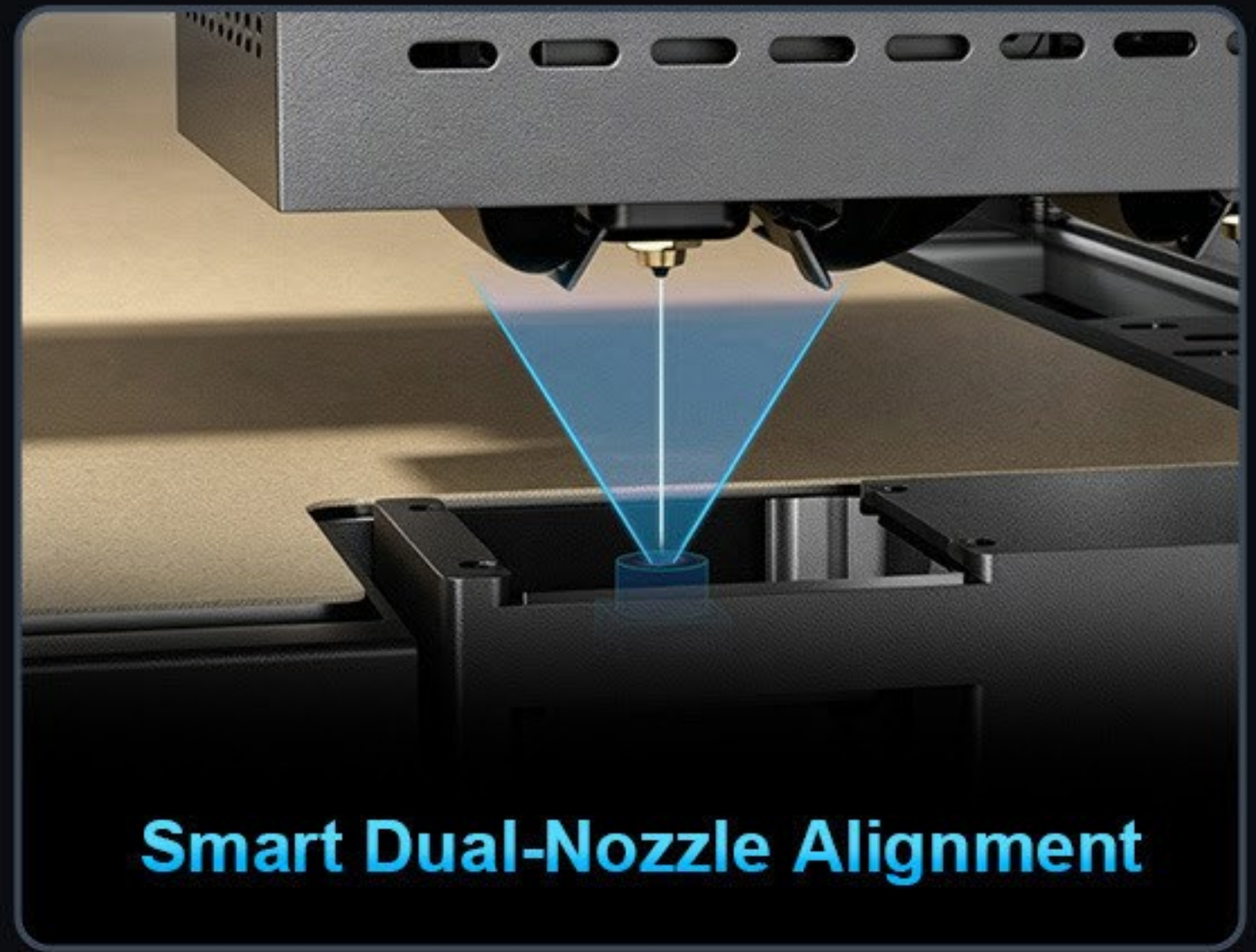

10" Integrated Touchscreen



Mobile App Remote Control

All-New Extruder

The redesigned extruder features a lightweight structure, and ultra-uniform extrusion delivery. With reduced weight and enhanced stability, it ensures consistent, high-precision results for every print job.



Smart Dual-Nozzle Alignment

AI-powered XY offset calibration eliminates manual adjustment. This greatly improves alignment accuracy and printing consistency, making dual-color and dual-material production simpler and more reliable.

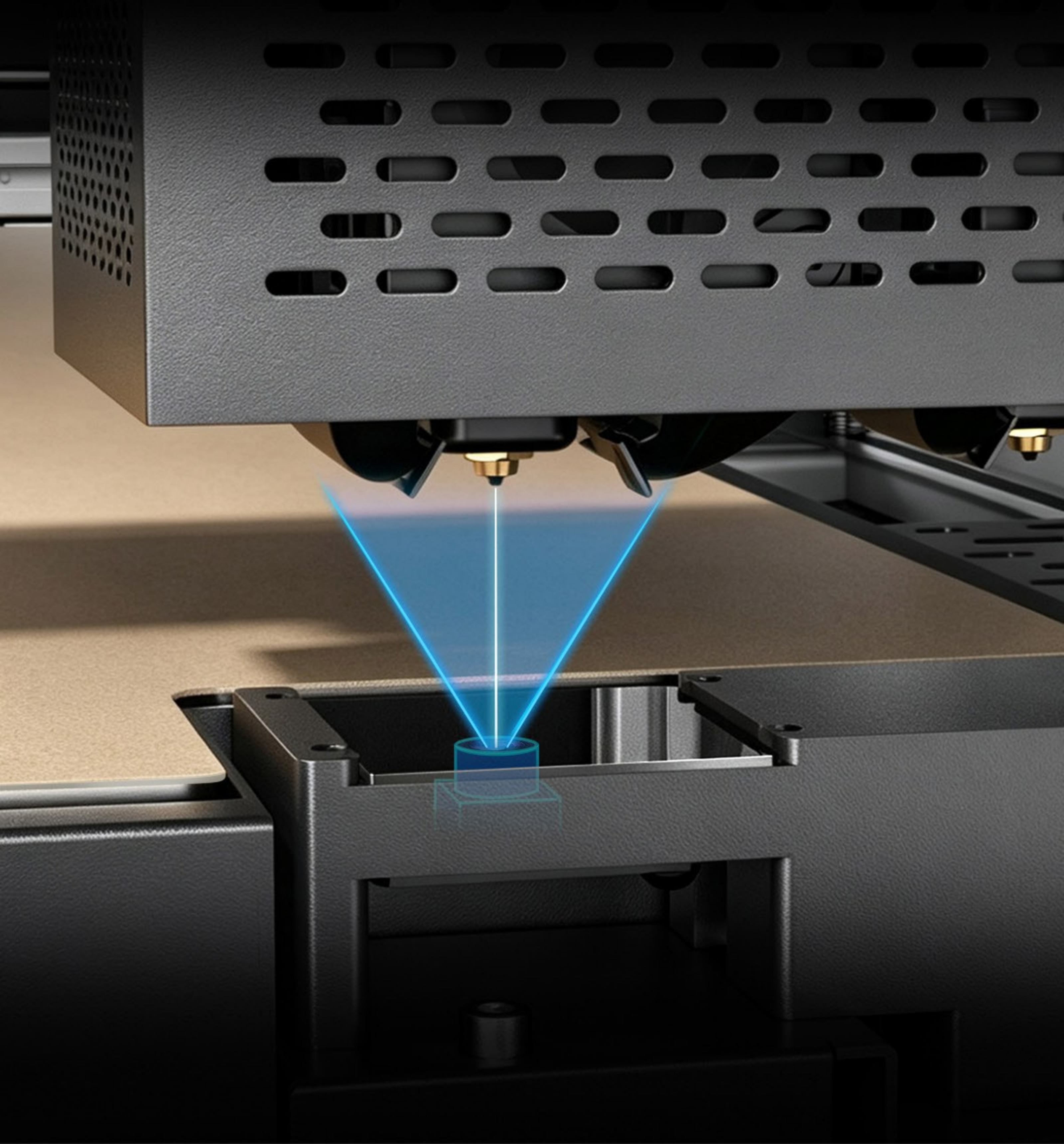

One-Touch Z-Offset Auto Calibration

The fully automatic Z-offset calibration system removes manual paper testing.

The printer automatically sets the ideal nozzle-to-bed distance for strong first-layer adhesion—easy enough for beginners to operate with confidence.

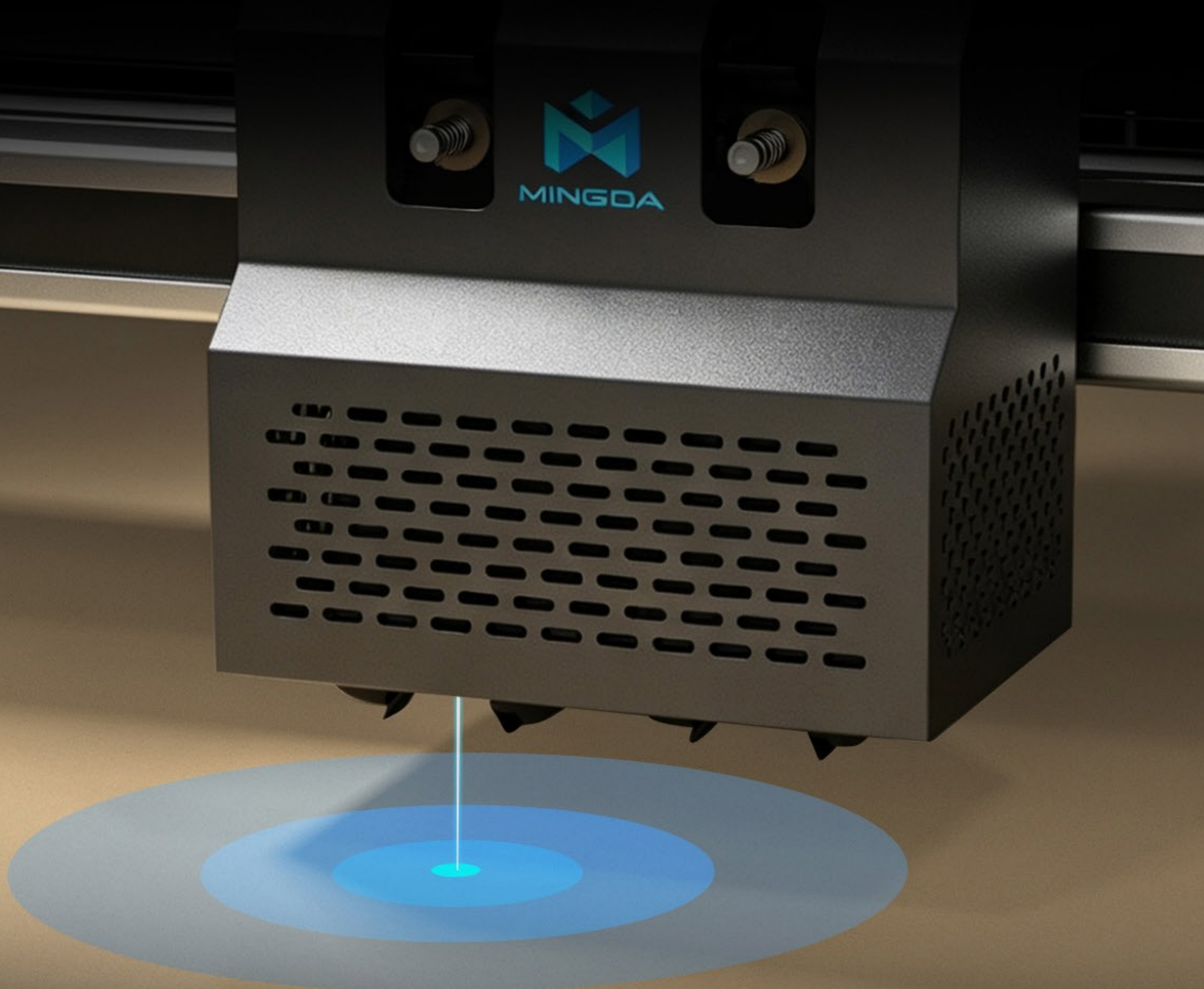

**Direct Drive
Dual Extrusion System**



**Supports soluble and
breakaway support materials**

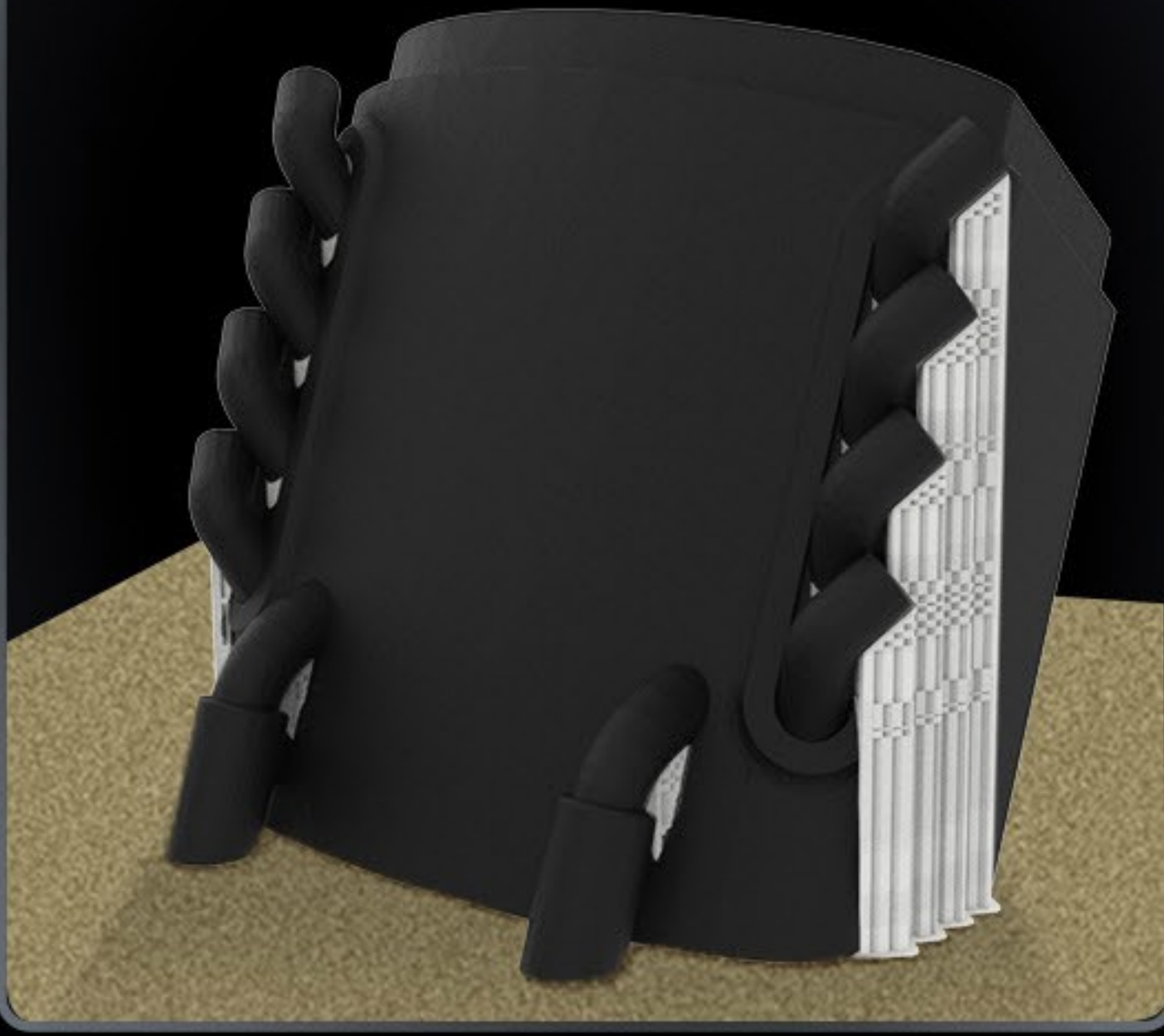

**Enables simultaneous
dual-color / dual-material printing**

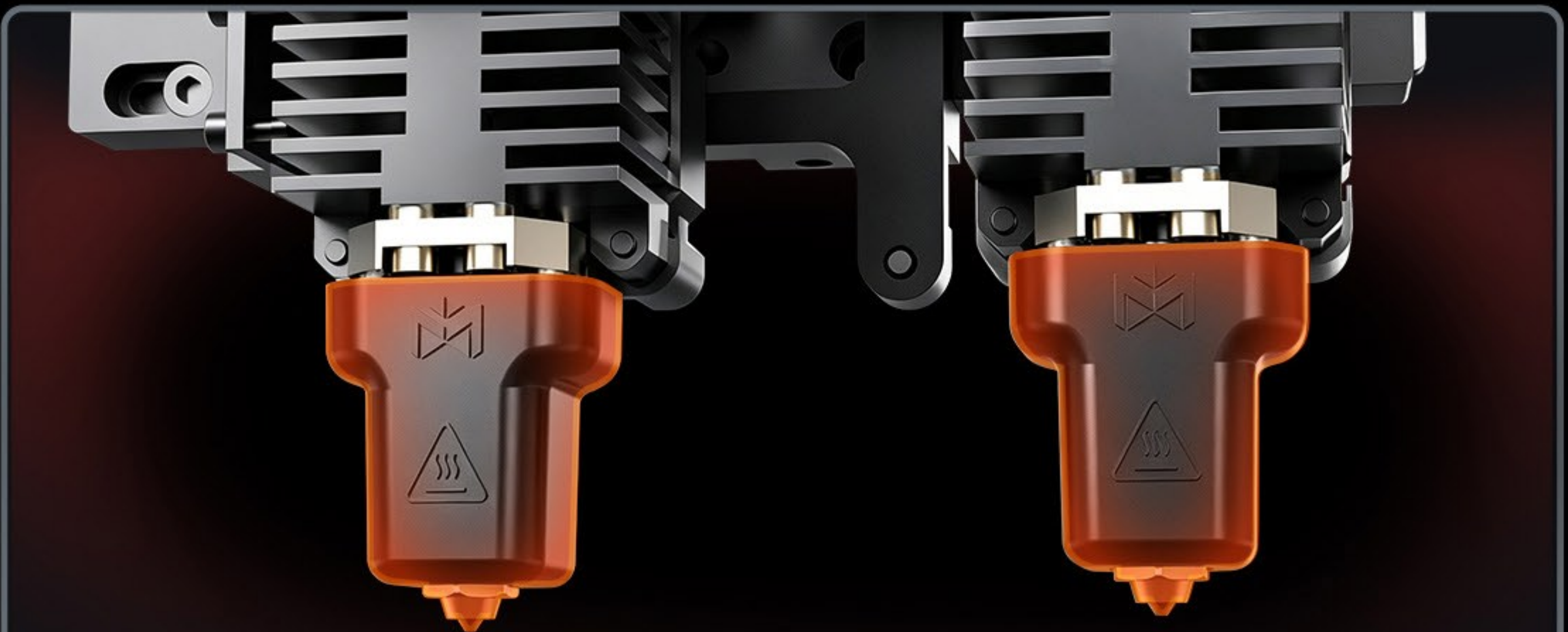
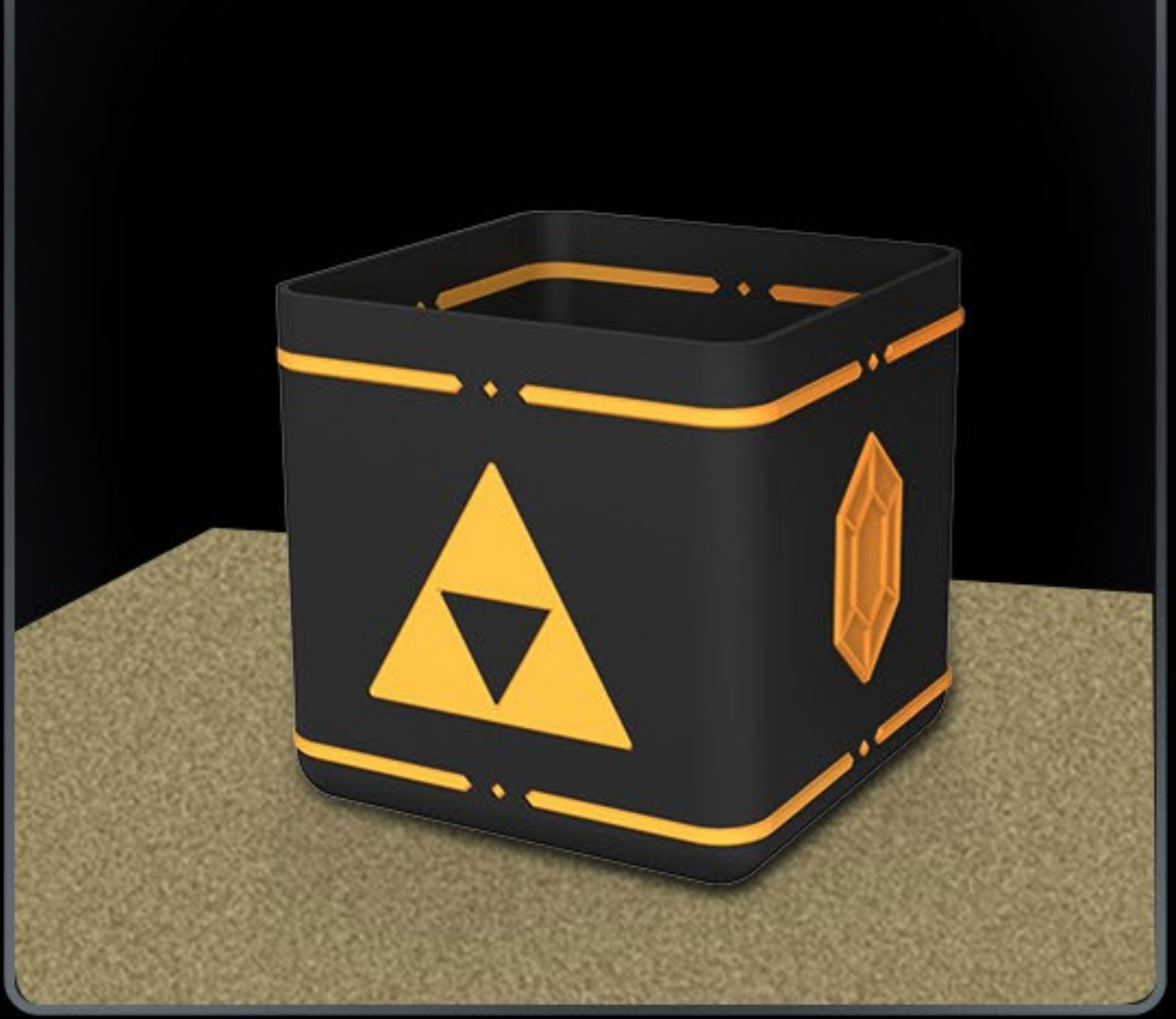

Maximum nozzle temperature

350°C

5X Higher Speed

Industrial-Grade Efficiency

The MD-1000D Ultra achieves breakthrough high-speed performance: printing speed up to 300mm/s, 10000mm/s² Peak acceleration, only 0.02s speed up form 0 to 300mm/s, achieving ultra-high efficiency printing.

300mm/s

Travel speed

200mm/s

High-Speed

40mm³/s

Max Flow

300 mm/s



High-Speed Slicing

MINGDA Slicer – our next-generation custom slicer – is optimized for high-speed printing with intuitive controls and extensive material presets.

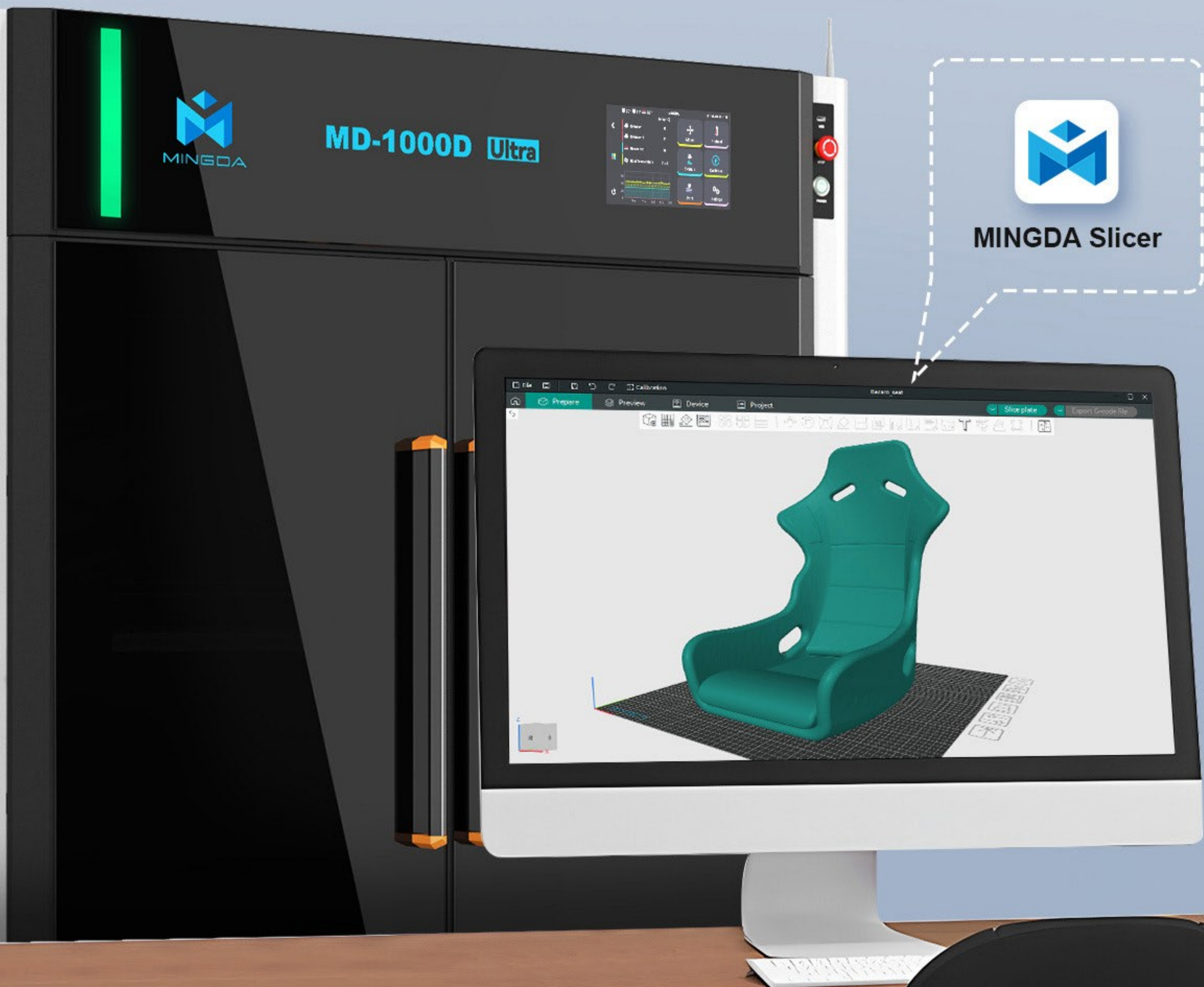

Real-World Benchmark:

Automobile Seat Case

Filament

PLA-HF

Speed

200mm/s

Model size

800*800*1000mm

Printing time

9 days



Standard printers: ~20 days at 50mm/s

* Data for reference only.

Massive Build Volume

1000*1000*1000 mm

Designed for oversized industrial parts, large prototypes, automotive components, and full-scale production models.

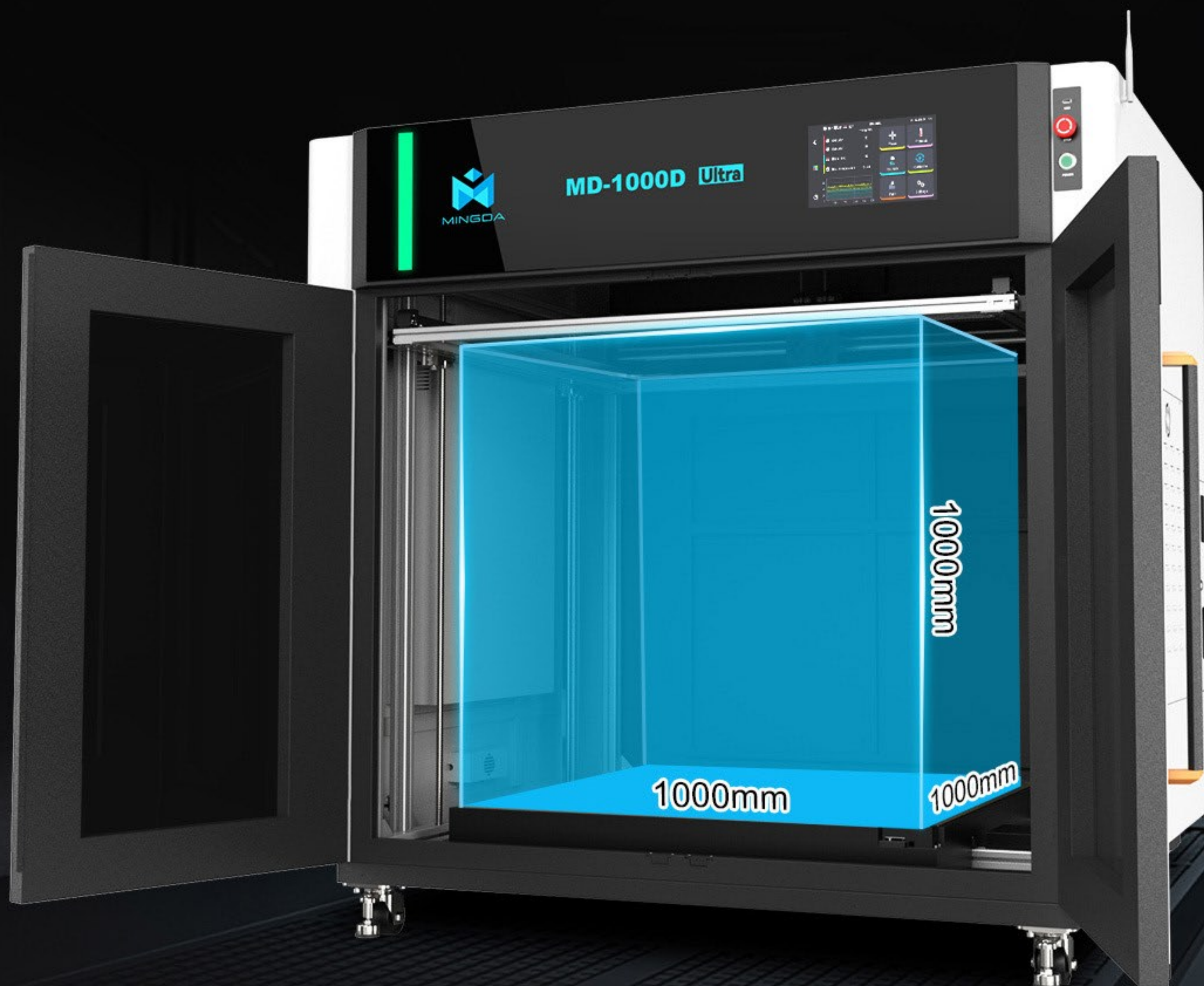

Service Commitment

Good after-sales service is the key to test whether a company manufactures high-quality products



One Year
Warranty



Lifetime
Maintenance
Support



Factory
Direct Supply



Strict Quality
Assurance



Professional
Technical
Support

Remote Control & Multi-Machine Management

Via Wi-Fi or Ethernet, the MD-1000D Ultra supports:

- Real-time remote monitoring and control
- Multi-printer management for mass production
- Mobile app dashboard for full operational control



**Monitor print status, adjust settings,
and track progress anytime, anywhere.**

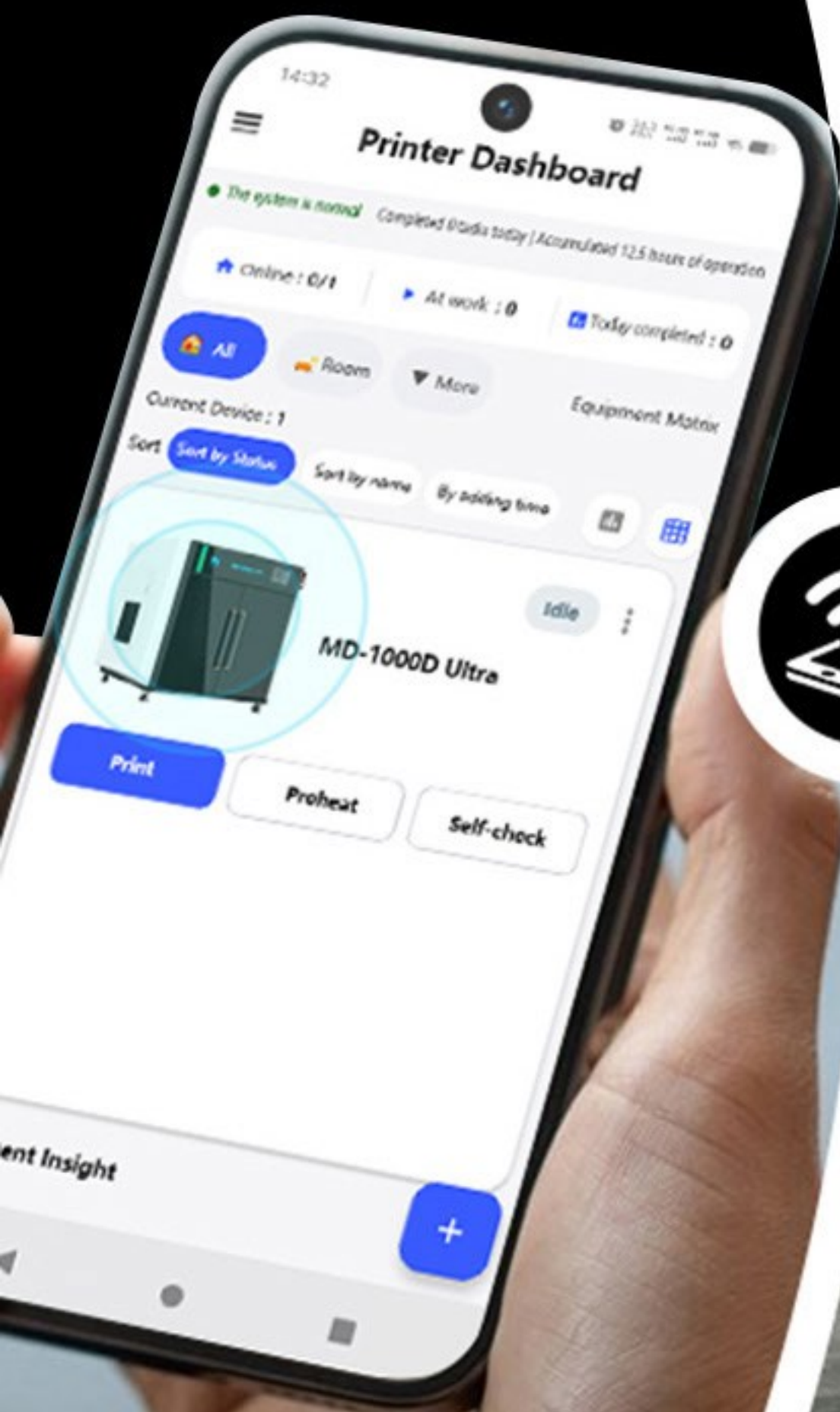

Intelligent & Precision Features

Hands-free Auto Leveling

Simplifies pre-print preparation with accurate first-layer detection.

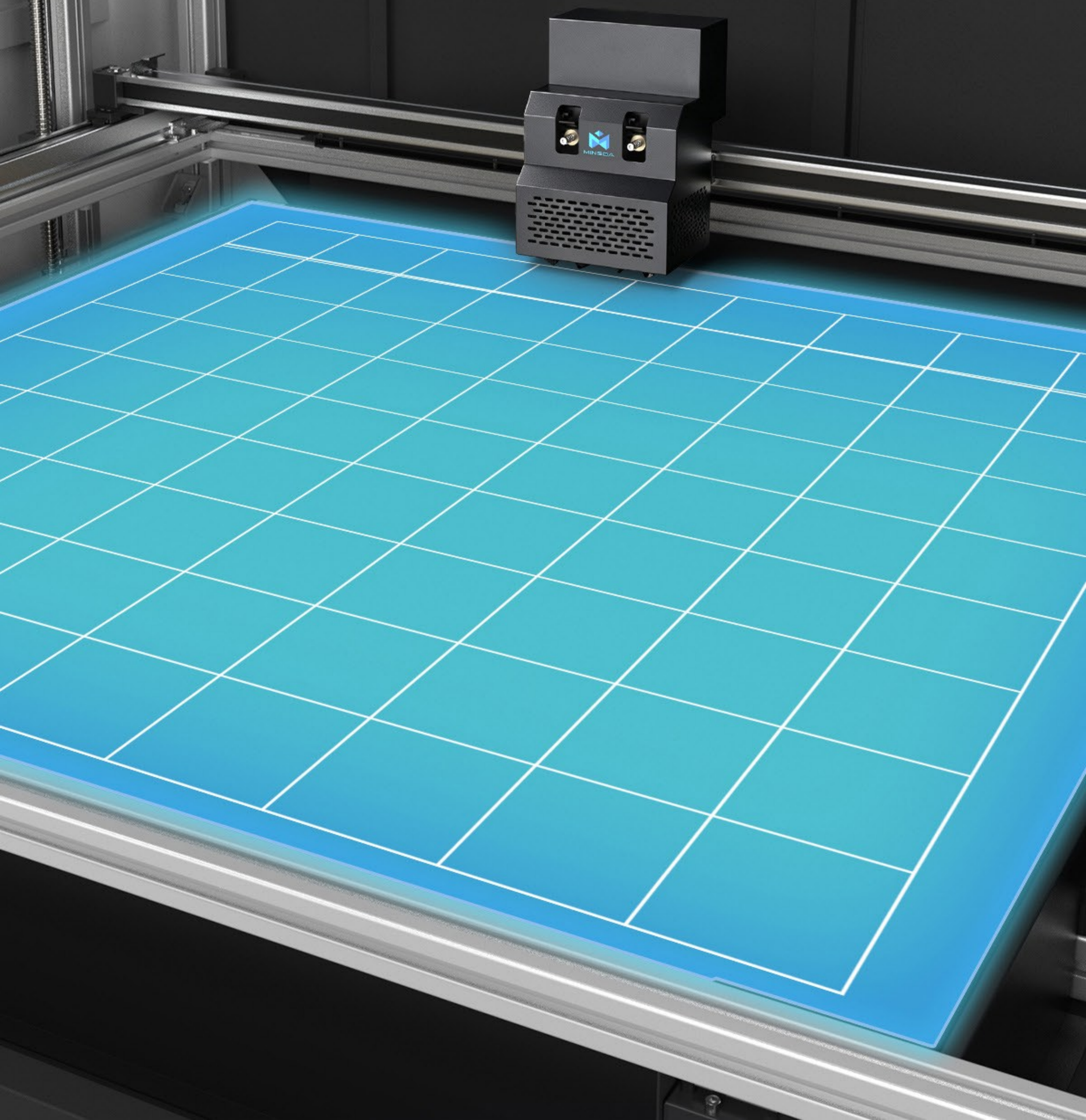

High-Precision Motion System

Modular guide rails + closed-loop control ensure stable, accurate printing throughout long jobs.

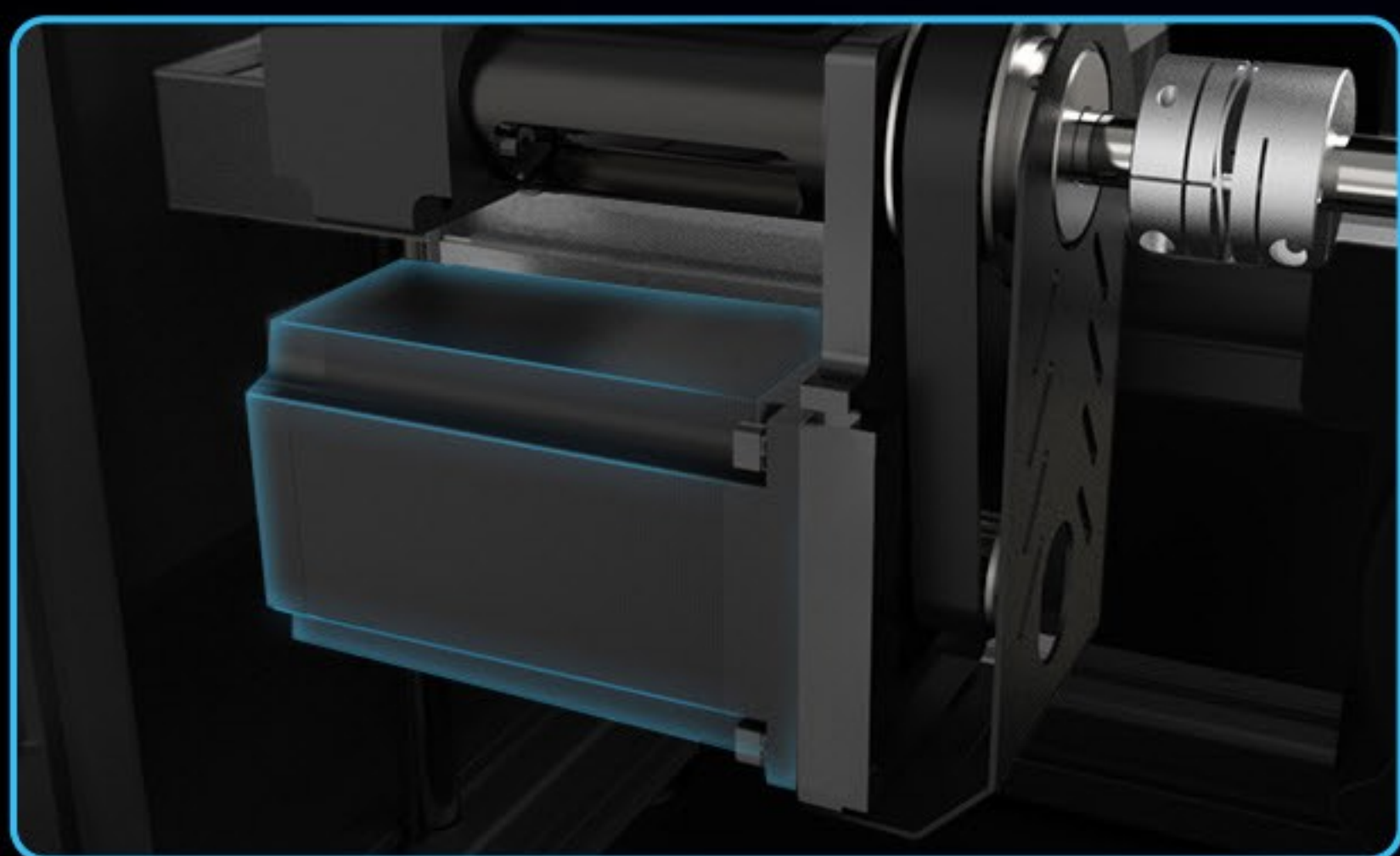
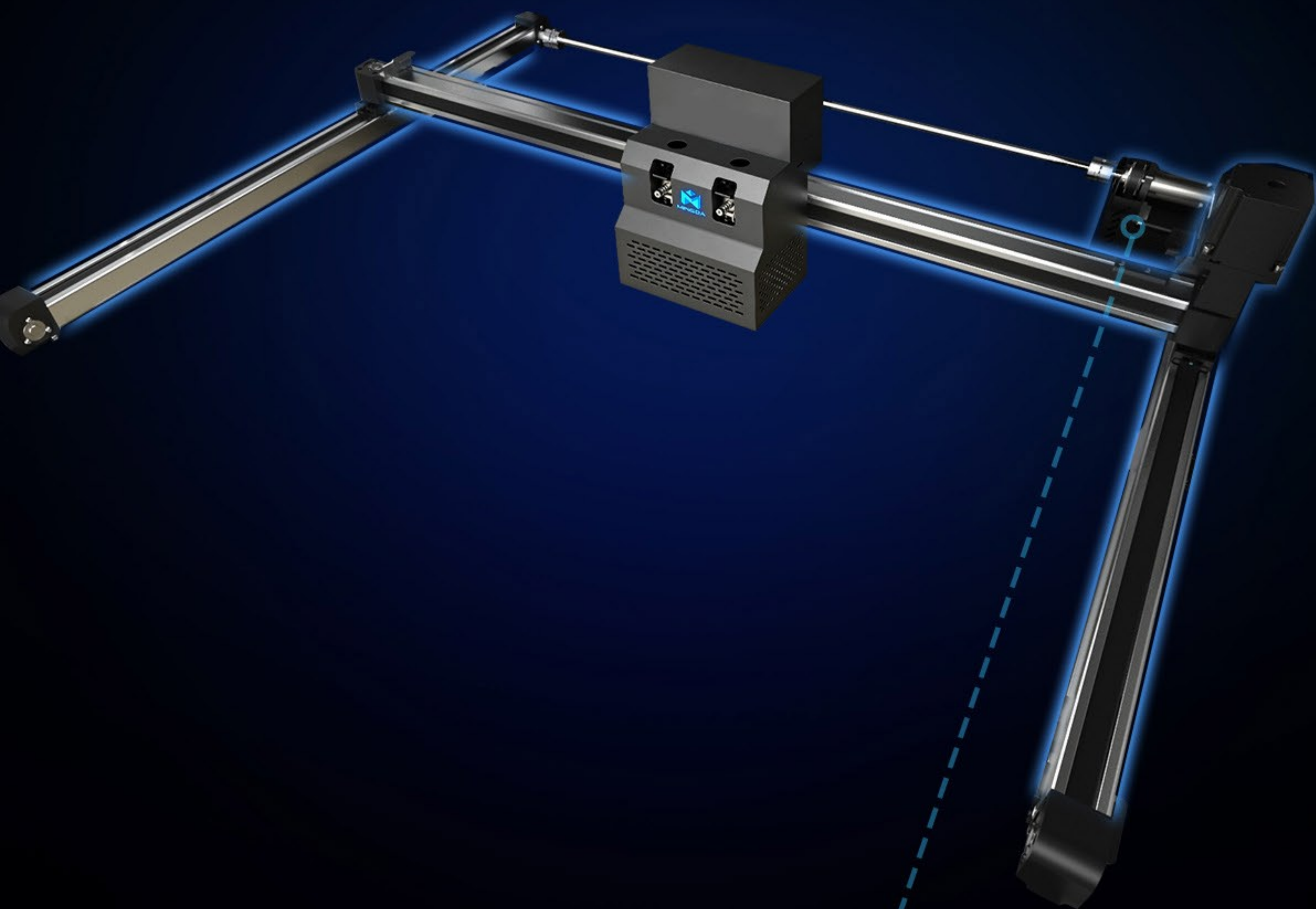

Closed-loop Stepper Motors

Delivers stronger feedback, faster movement, higher precision, and lower heat compared to traditional open-loop motors.

Premium Print Quality Upgrade

With optimized motion control and compensation algorithms, vibration patterns are effectively reduced while arc precision and surface finish are significantly improved.

Every design detail becomes clearer, every finished part looks smoother



Input Shaper

Reduces vibration and ghosting for ultra-smooth surface finishes.

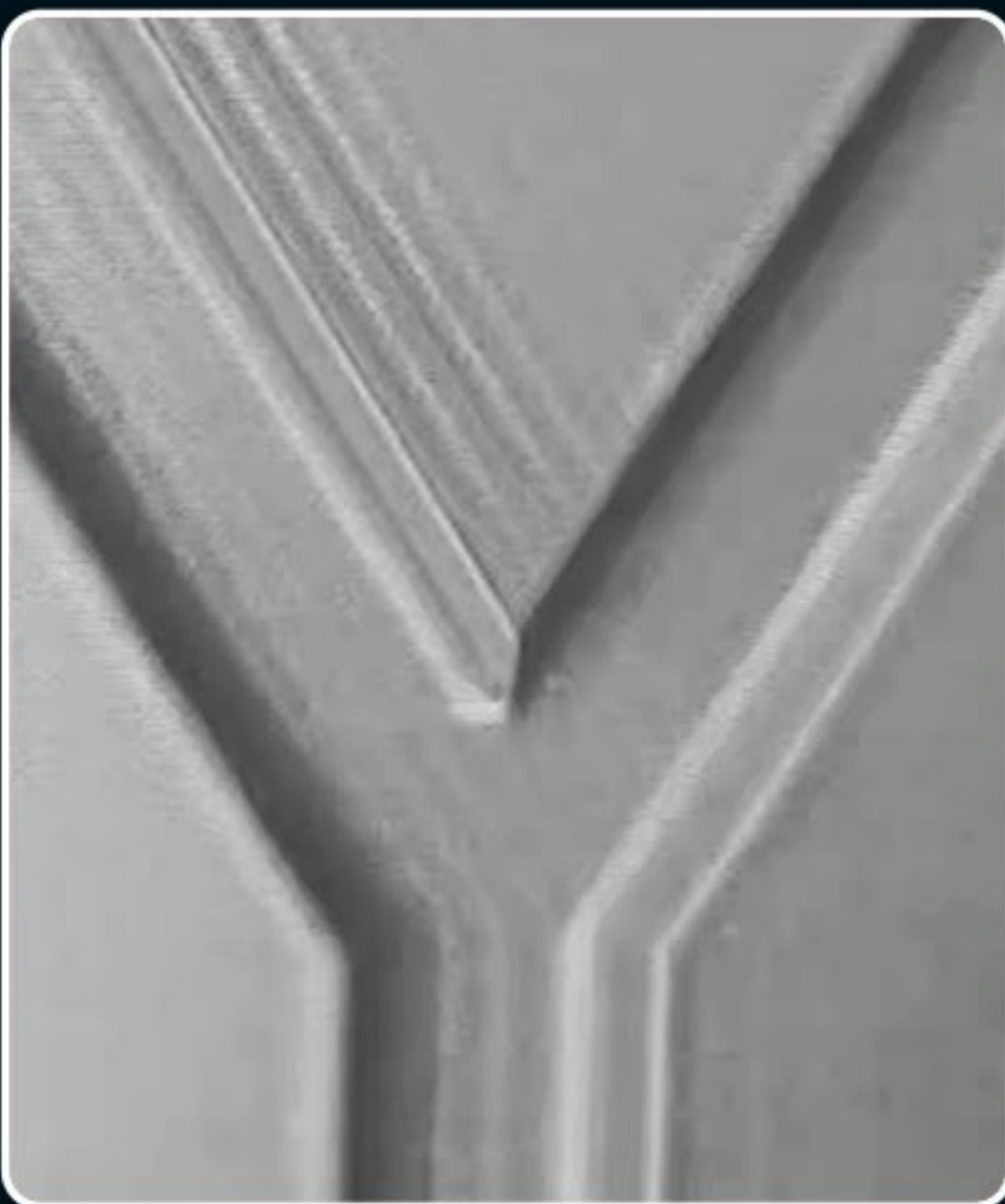

OFF

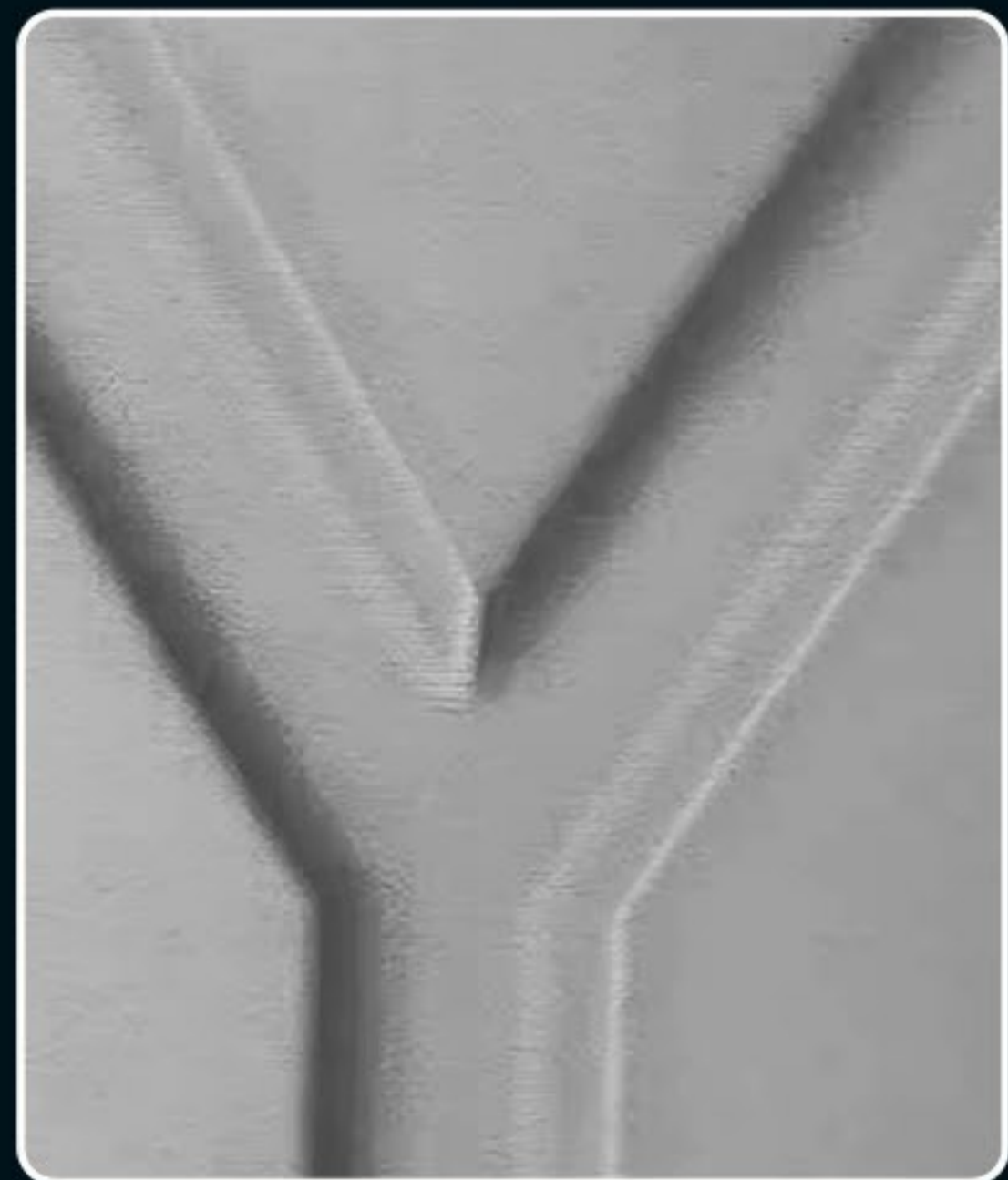

ON

Dual Cooling System

Aerodynamic air duct design provides focused high-velocity airflow to prevent stringing, warping, and oozing.



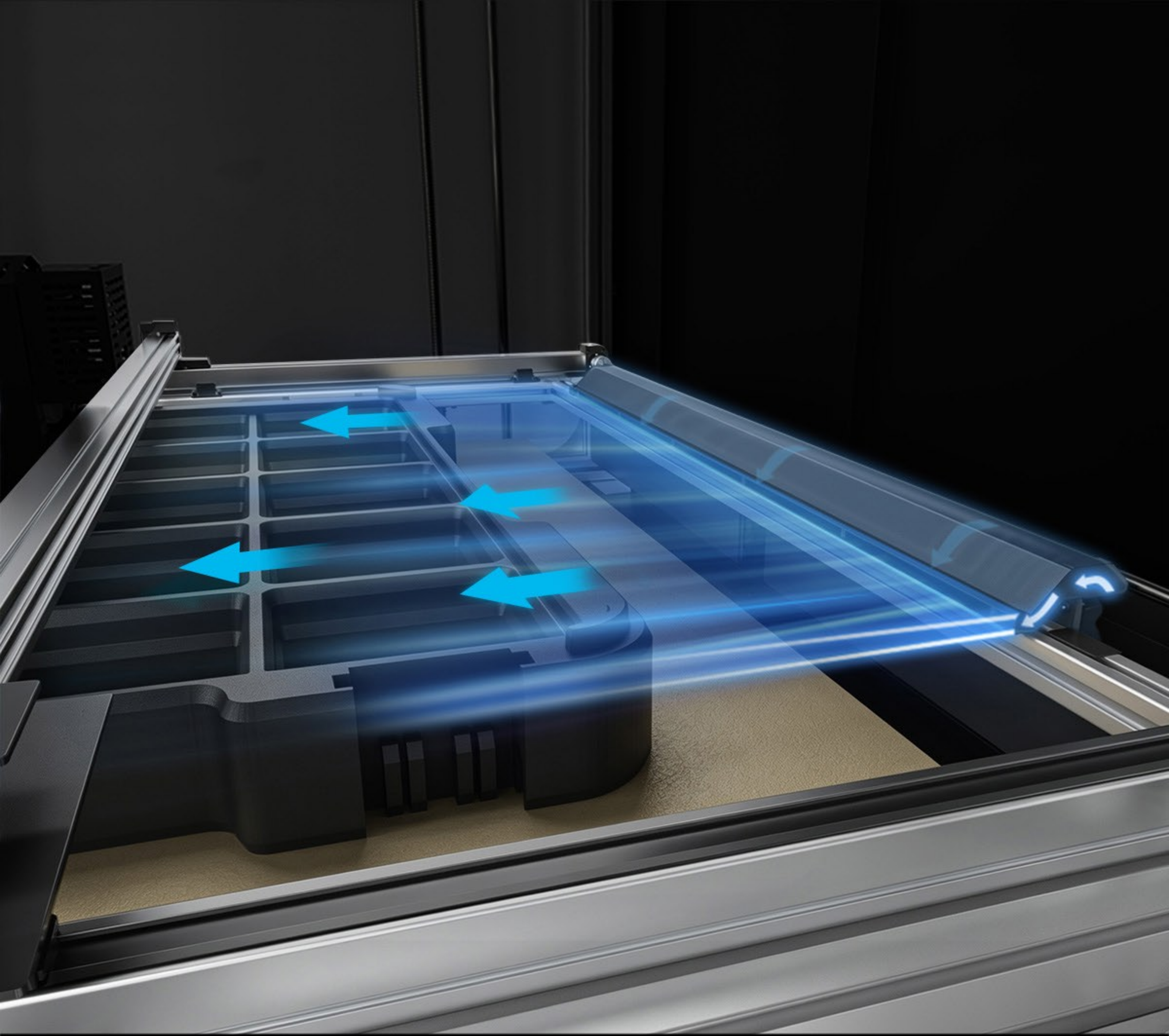

Speed cool solidification, effectively avoid stringing, warping

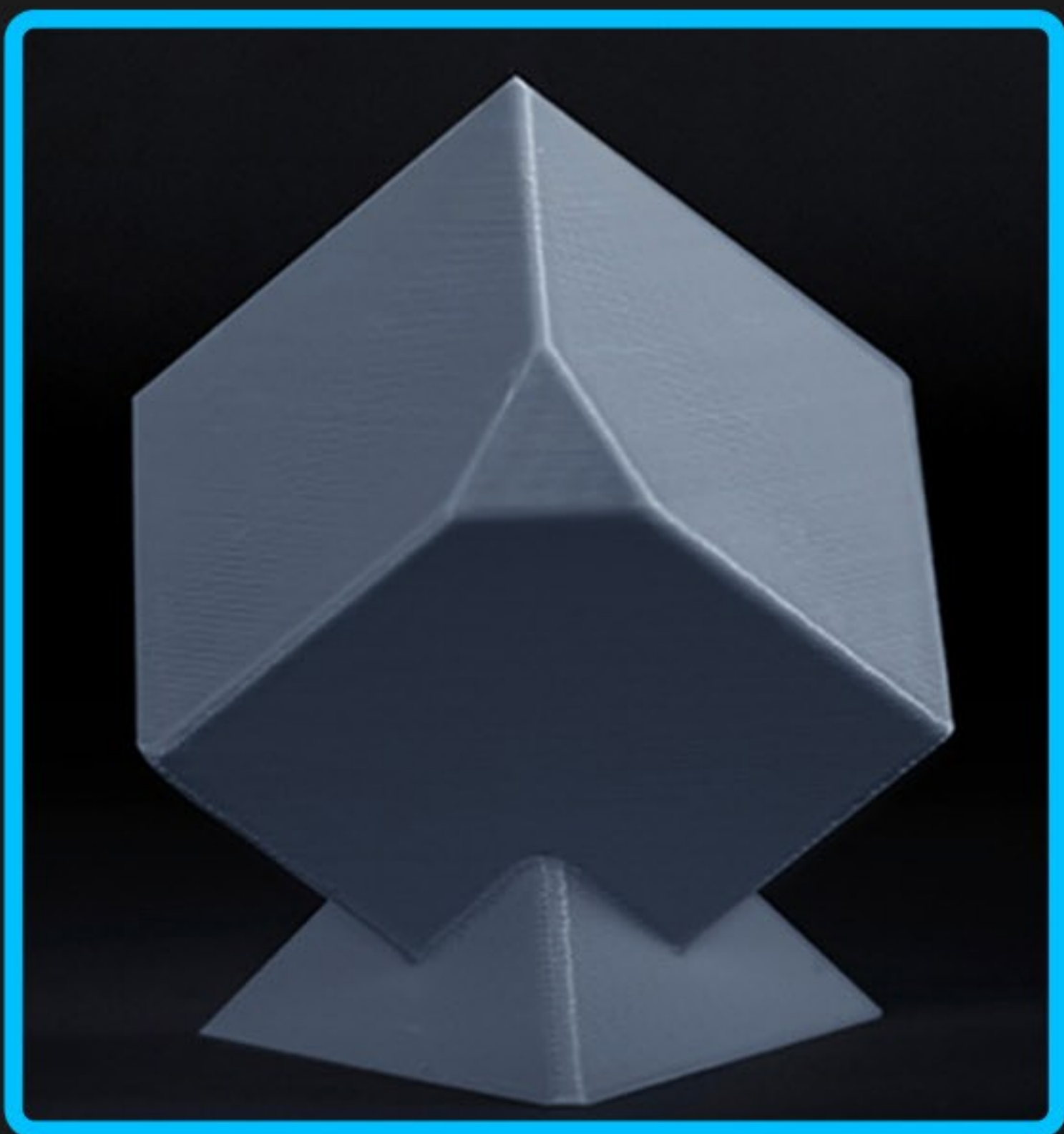

Mingda air cooling effect



Regular air cooling effect

PEI Flexible Build Plate

Strong filament adhesion, high-temperature resistance,
and easy part removal via flexible bending.

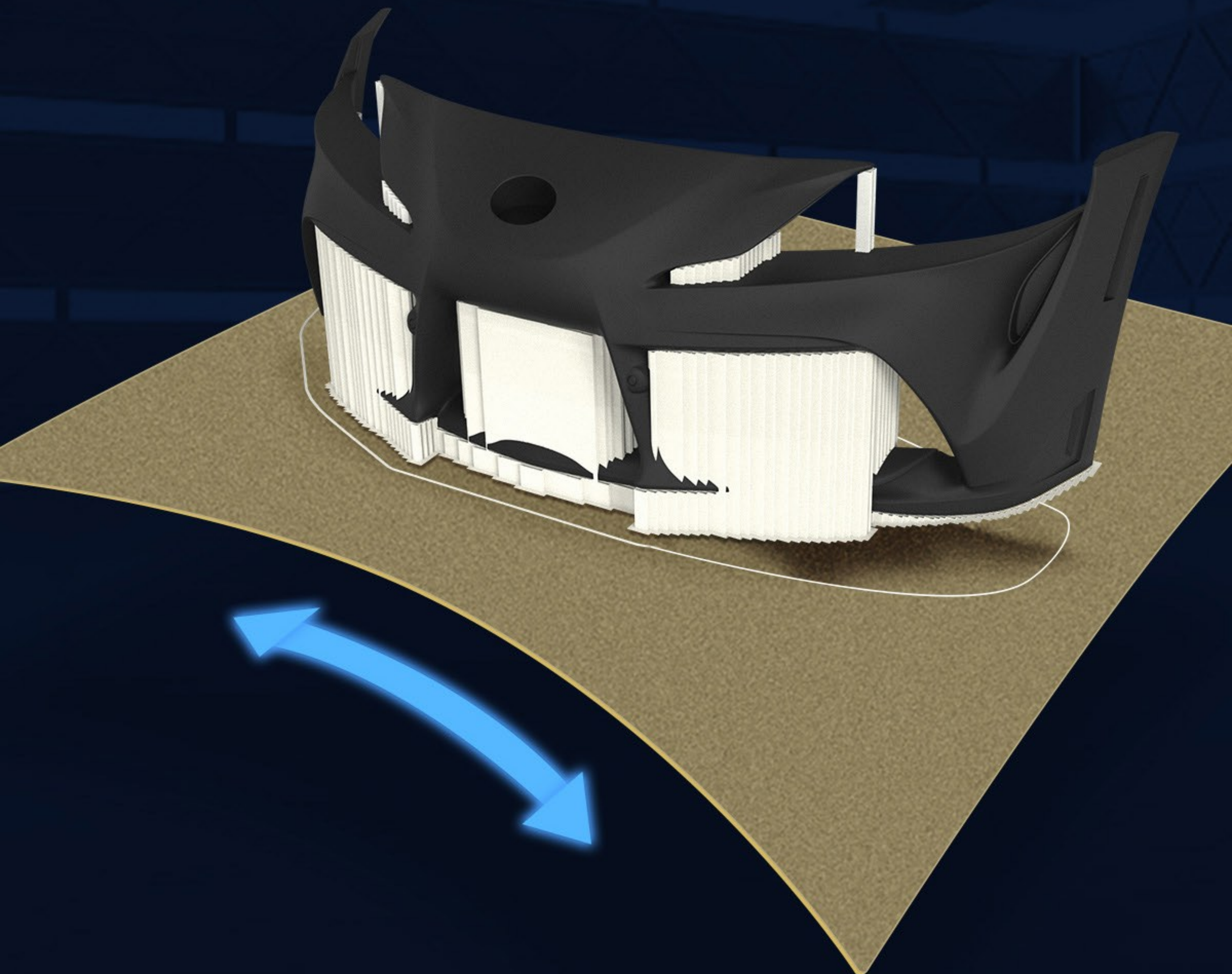

Proprietary MINGDA Mainboard & MINGDA PI

Upgraded self-developed computing platform delivers faster response, smoother UI, and improved system stability.

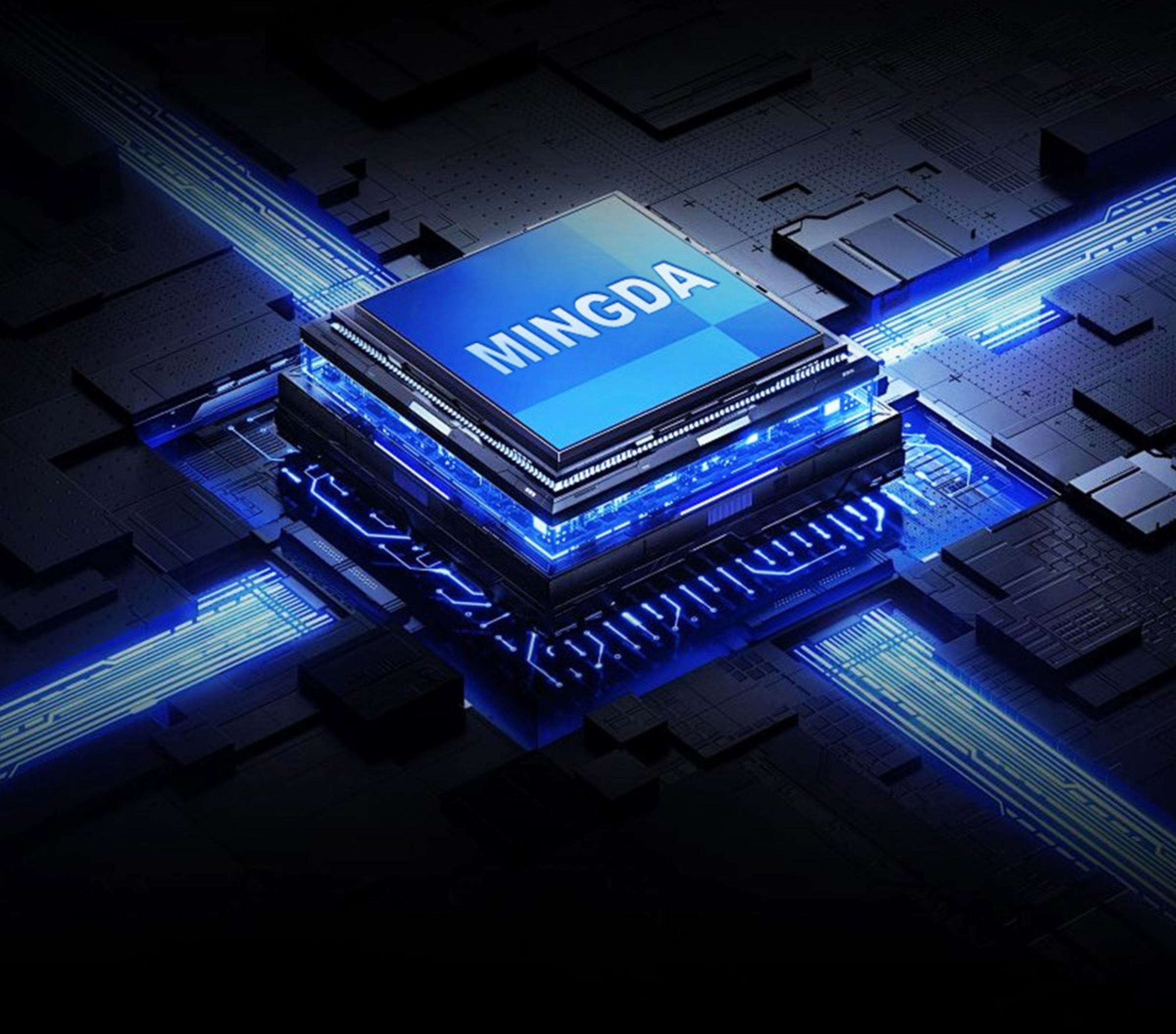

10" IPS Touchscreen

Smartphone-like fluid operation, clear graphics, step-by-step guidance, and multi-language support.



Support multiple languages

- | | | | |
|------------|--------------|--------------|-------------|
| 1. English | 6. Hebrew | 11. Poland | 16. Ukraine |
| 2. Danish | 7. Hungarian | 12. Portugal | 17. Chinese |
| 3. German | 8. Italian | 13. Russia | 18. Dutch |
| 4. Spanish | 9. Japanese | 14. Sweden | 19. Czech |
| 5. French | 10. Korean | 15. Turkey | etc |

Power on Self Check

Automatically verifies status of extruder, heated bed, camera, auto-leveling, fans, and sensors. Errors are displayed immediately for fast maintenance.





Power Loss Recovery



Automatically resumes printing after unexpected power outages.

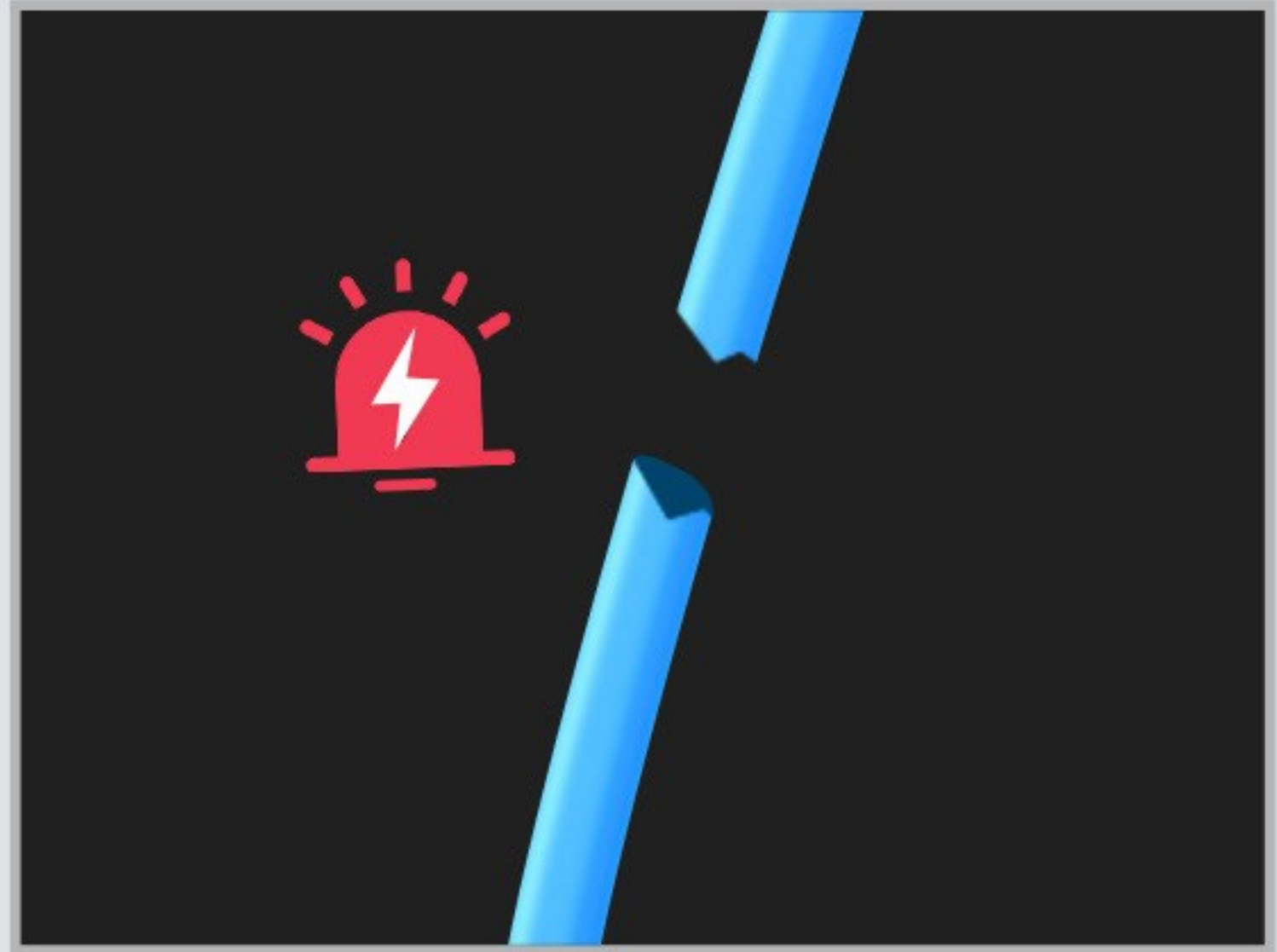

Filament Runout Detection



Pauses printing if filament breaks or runs out, preventing failed prints.

Broad Filament Compatibility

Standard

PLA, PETG, etc

Engineering

S-Multit, S-HtPA, etc

High-performance

PETG-CF, PET-CF/GF, HtPA-CF/GF, PA12-CF,
HtPA-GF25/CF25, PPS, PPS-CF/GF, etc



Applicable Industries



Automotive

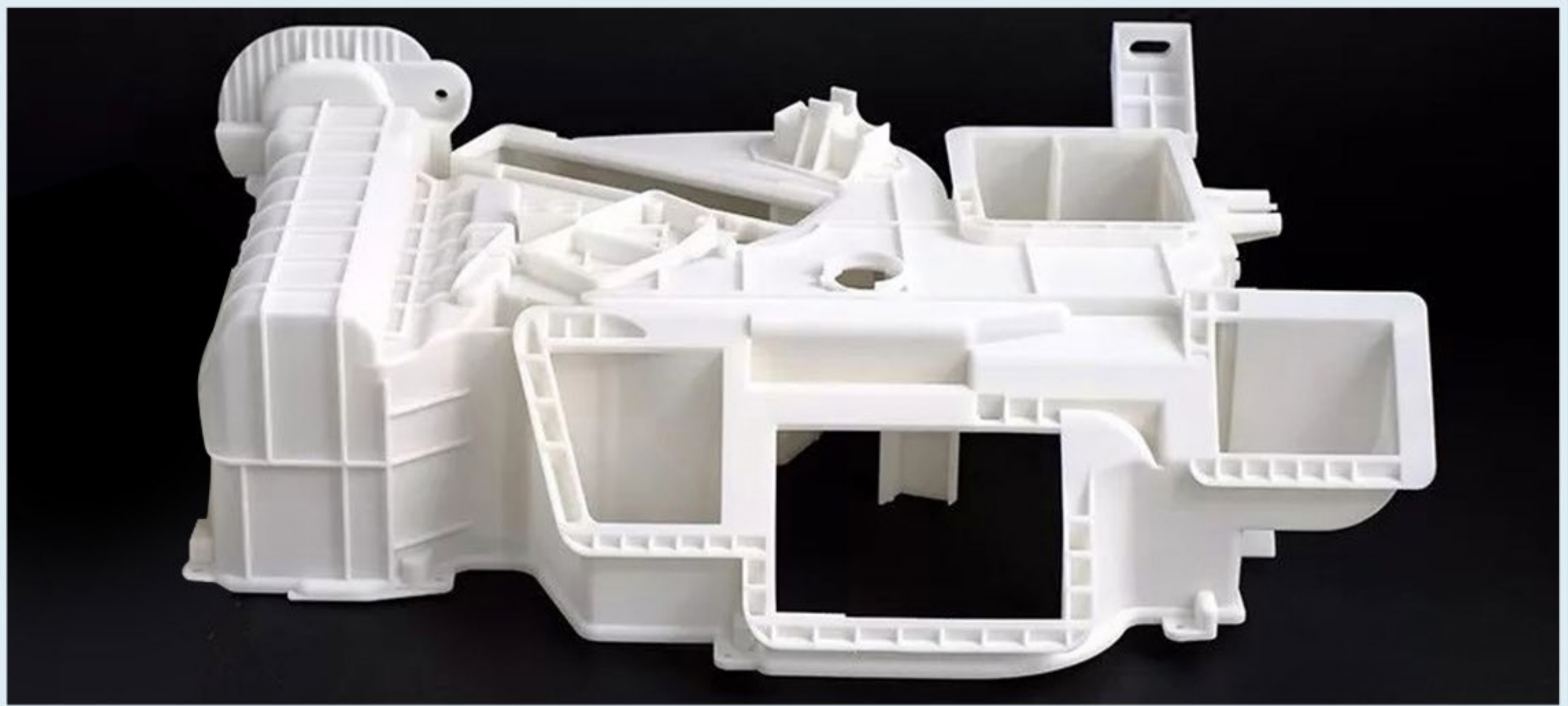

Functional prototyping



Jigs & Fixtures



End-Use Parts



Portrait

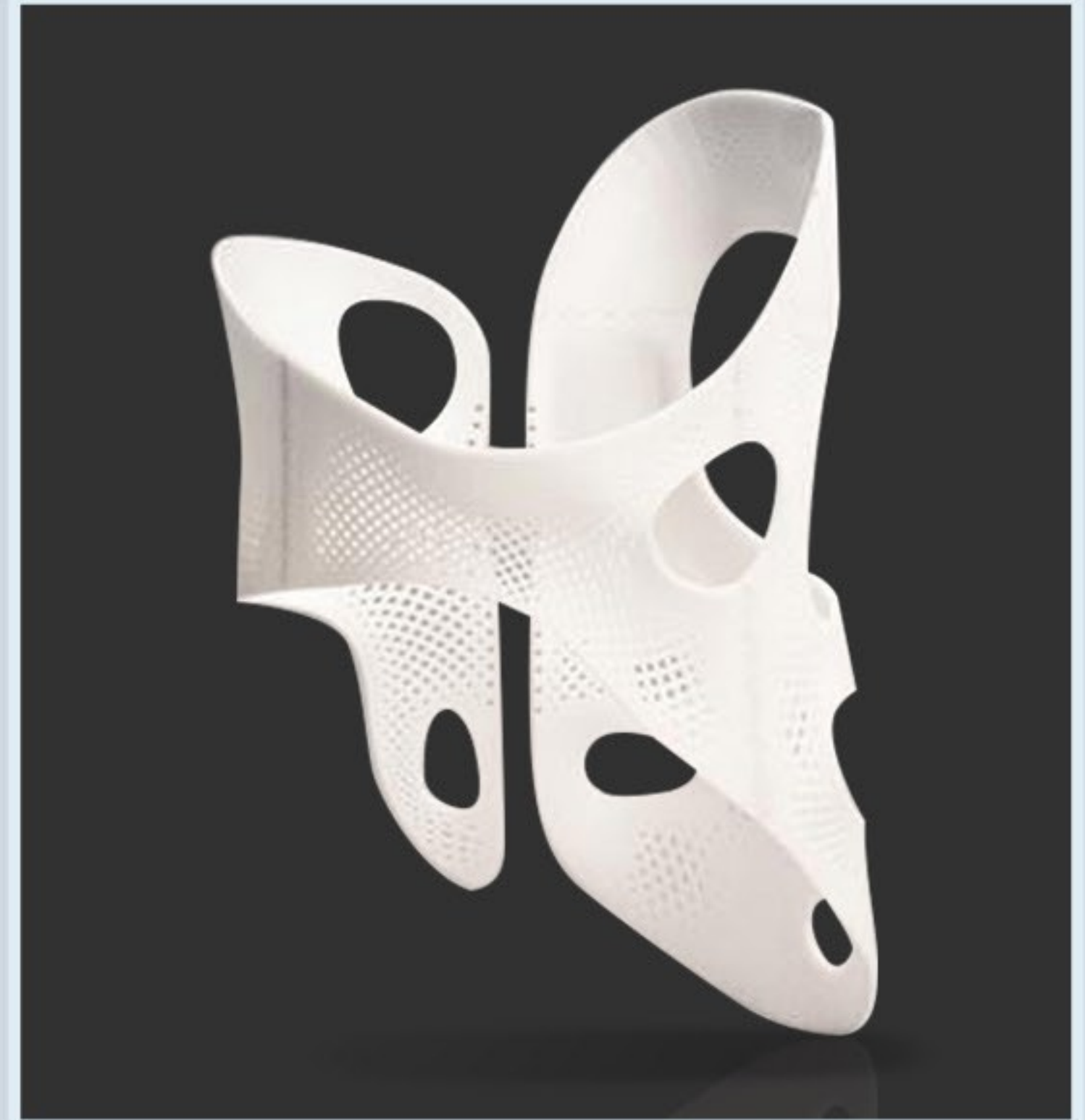

Medical

Product Parameters

Printing

Model	:	MD-1000D Ultra
Print Technology	:	FDM (Fused Deposition Modeling)
Build Volume	:	1000*1000*1000 mm
Extruder Type	:	Dual Extruders
Layer Height	:	0.3-0.36mm (Layer height is determined by the standard nozzle size)
Filament Diameter	:	1.75mm
Filament Types	:	PLA, PETG, PETG-CF, PET-CF/GF, PA12-CF, ABS-CF/GF, HtPA-CF/GF, HtPA-GF25/CF25, PPS, PPS-CF/GF, S-Multi, S-HtPA, etc
Nozzle Diameter	:	0.6mm (optional: 0.4mm, 0.8mm)
Print File Type	:	Gcode

Temperature

Max Nozzle Temperature	:	350 °C
Max Heated Bed Temperature	:	110 °C
Chamber Temperature	:	45 °C

Speed

Printing Speed	:	Up to 300mm/s (Recommend Printing Speed: (PLA)200mm/s; (PETG)180mm/s; (PET-CF)100mm/s)
Max Flow	:	40mm ³ /s
Moving Speed	:	Max.XY 500mm/s, Max.Z 15mm/s

Electrical

Maximum Power	:	3100W
Input Voltage	:	220V 50/60Hz
Connectivity	:	WiFi, Ethernet, USB
Screen	:	10" IPS Touchscreen

Security Parameter

Safety Design	:	Three color warning light, Emergency Stop
Certification	:	CE

Software

Slicing Software : MINGDA Slicer

Data Type : .3mf .stl .stp .step .amf .obj

Operating System : Windows/Mac OS

Special Function

Firmware : Klipper

XY-Offset Technology : AI-Powered Camera calibration

Z-offset Technology : Probe calibration

Cooling System : Air-cooled

Machine Detection : Power-On Self-Check

Remote Management : Remote Monitoring & Control; Remote Printing

Resume Printing : Power Loss Recovery

Printing : Remote Printing

Printing Performance : Input shaper

Mechanical

Printing Platform : 10mm thick aluminum plate+magnet+PEI

Leveling : Auto Leveling + AI Calibration

Extruder Type : Dual Extruders

Resolution : XY: 20 μ m; Z: 10 μ m

Printing Chamber : Enclosed chassis

Sports System : Closed-loop control system

Filament Chamber Design : 2 rolls of 3kg filament, auxiliary feeding, Moisture-proof filament chamber

Dimensions and Weight

Machine Dimensions : 1710*1365*1665 mm

Package Dimensions : 1980*1630*1920 mm

Package Weight : 654.5KG 6.2CBM