

Modix

Modix MAMA 1000

Product Brochure

Distribuito da 3DTIME.it

info@3dtime.it

tel. +39 (0)59 776377



Technology

Dual FGF (Fused Granulate Fabrication) & FFF (Fused Filament Fabrication) Technologies

Create large-scale, production-grade 3D prints with Modix's versatile MAMA 1700. Leverage pellet 3D printing for high throughput and material cost efficiency, ideal for producing signage, props, molds, and furniture. Additionally, it offers the option to use recycled materials for eco-friendly manufacturing. The integrated high-speed filament 3D printing capability ensures detailed and precise results, making the MAMA 1700 suitable for a diverse range of applications. Delivered as a self-assembly kit, the printer can be installed virtually anywhere make it ideal for smaller rooms. It also provides end customer with independent maintenance and future upgradeability options for longer ROI.

Specifications:

- Printing Volume: 1.7 x 1 x 1 Meter (XYZ)
- Printer Dimensions: 1.53 x 2.1 x 2.35 Meter (XYZ)
- Pellet Extruder: DYZE Design Pulsar
 - Flow Rate: 500 mm³/s, up to 3 KG/hour
 - Nozzles Included: 3mm & 5mm
- Filament Extruder: Griffin Ultra, 1.75 mm filament, 1.6 nozzle
 - Flow Rate: 160 mm³/s, up to 0.5 KG/hour
- Air Compressor: Required, not included
- Motion: Closed-loop Nema23 Motors



Dyze Pulsar Pellet Extruder
3KG / Hour



Modix Griffin Ultra Filament Extruder
500 gr / Hour

Applications

Molds

This low temperature Mold was made with wood filled PLA pellets. Wood filler makes it very easy for post processing including sanding, drilling etc.

- Length: 1.4 Meter
- Weight 7 kg
- Print time 5 hours

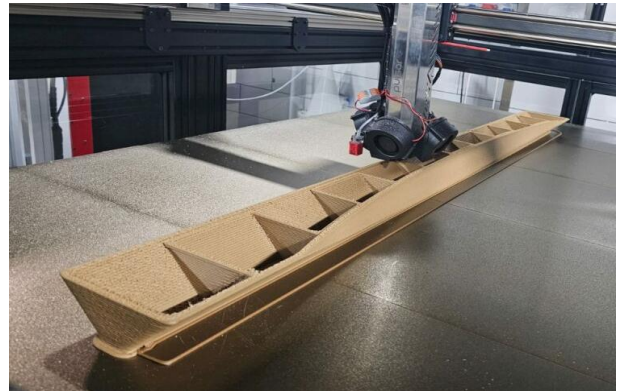

Furniture

With 1.7-meter bed length, MAMA-1700 has a unique size that allows production of innovative designs for bookshelves, table bases, coffee tables and light fixtures. Local production made with recycled plastic is a strong trend appreciated by consumers.

- 4.5 hours
- 5.5 kg
- Nozzle – 5mm
- layer height – 3mm
- PLA with matt additives

Signage & Props

Various large letter, logos and symbols made with flame redundant material as required for installation in public locations. Print parameters for the “bat” sign:

- 8.75 hours
- 10.1 kg
- nozzle - 5mm
- PLA & White masterbatch



Add-ons

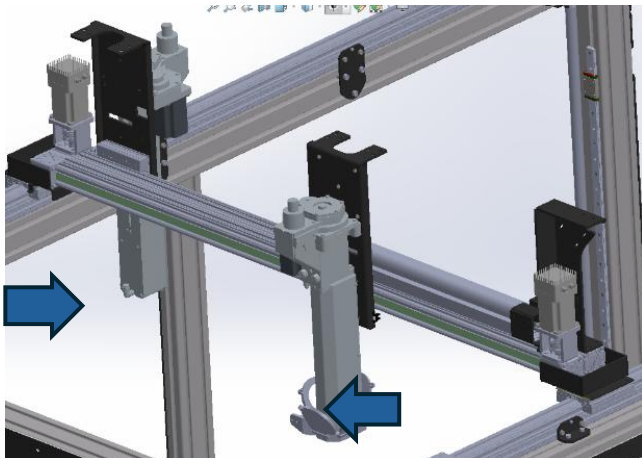

IDEX – Dual print head

IDEX enables true multi-material printing and clean support removal in a single print job.
(Lead time - Late 2025)



Pellets Dryer

Pellets dryer is a must add-on for almost any type of pellets as they absorb higher amount of moisture than filament.



Pigments Mixer

A pigment mixer ensures even distribution of colors and additives throughout long prints for consistent results.



Air Filter Device

An air filter removes harmful particles and fumes, ensuring a safer and cleaner printing environment.