

# Design, fabrication and testing of an ultra-clean power supply with continuous output

Jan Kucera

15.5. 2026, Lisbon, Portugal

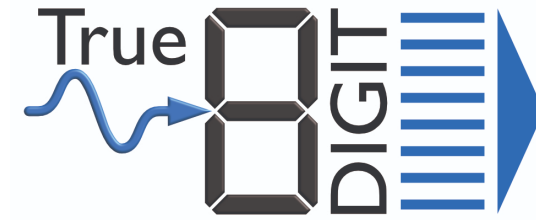

METROLOGY  
PARTNERSHIP



# Motivation

A precision digitizer requires a high quality power supply unit (PSU) with:

- Several voltages for metrology grade ADCs, COPAs, timing circuits
- Continuous operation - supplied from the mains
- Improved line supply interference suppression
- Low noise
- Immune to temperature and load changes
- Robustness – internal monitoring

# Requirements

Voltage Levels	Current Levels	Noise Level	Stability	Required for
+18 V; -18 V	100 mA	Ultra quiet	High	Input COPA, Integrator COPA
+5 V; -5 V	200 mA	Quiet	High	integrator logic, additional analog circuits
3.3 V	0.3 A	5%	5%	Galvanic isolators for FPGA
+5 V; -5 V	4 A	5%	5%	Clock, FPGA

# Design

Two possible approaches for low noise and high isolation PSU:

- Battery packs with switching
- Switched mode DC-DC adapter with special design to achieve high isolation

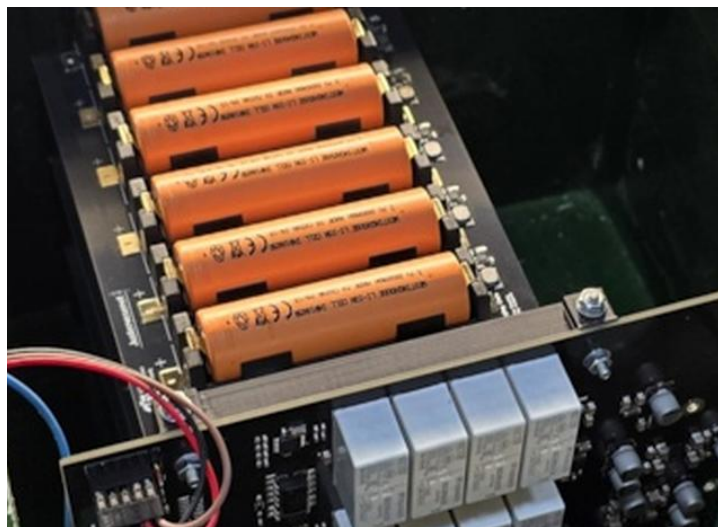

# Design

Concept based on battery switching

Modular approach

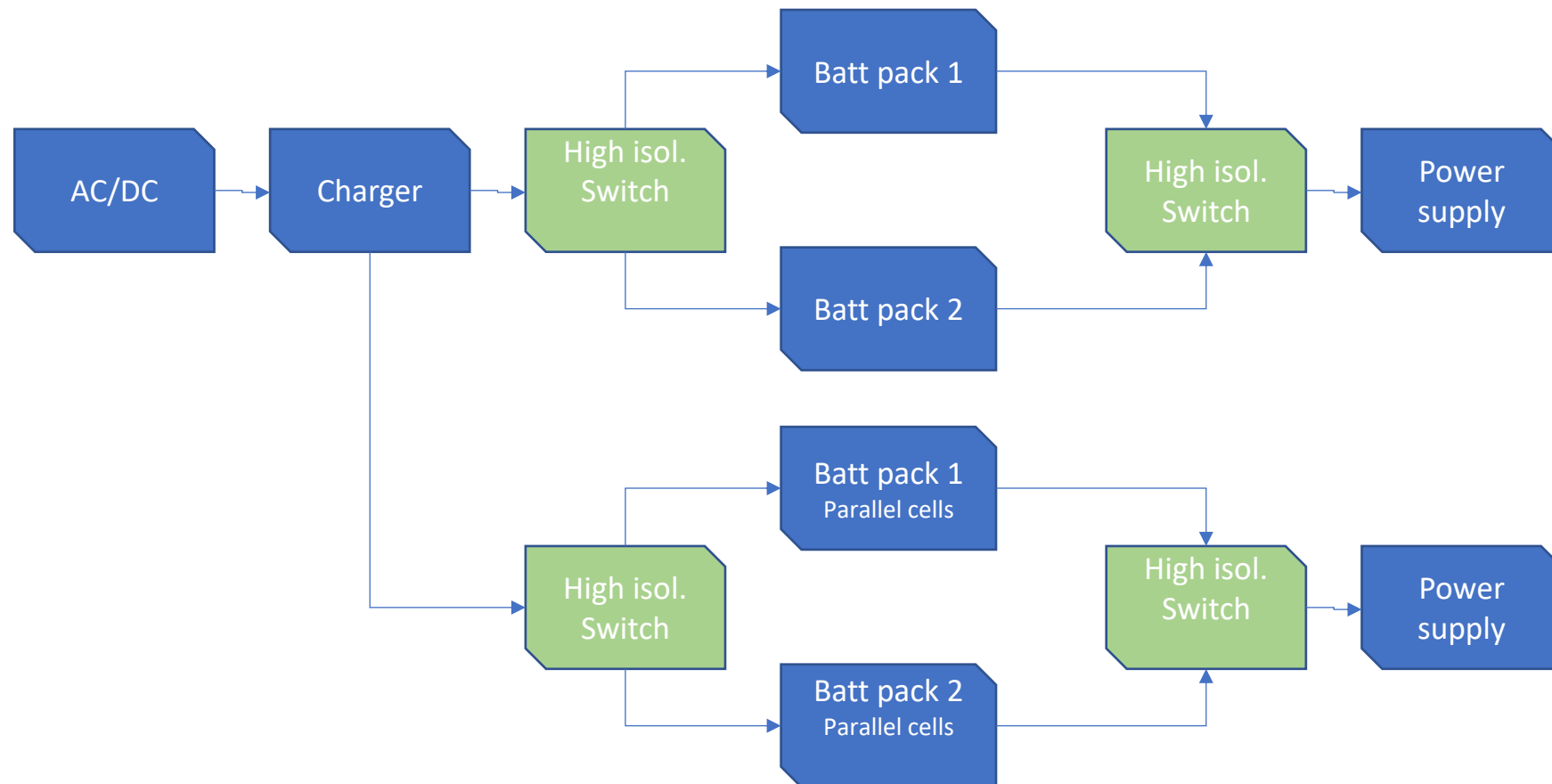

# Design

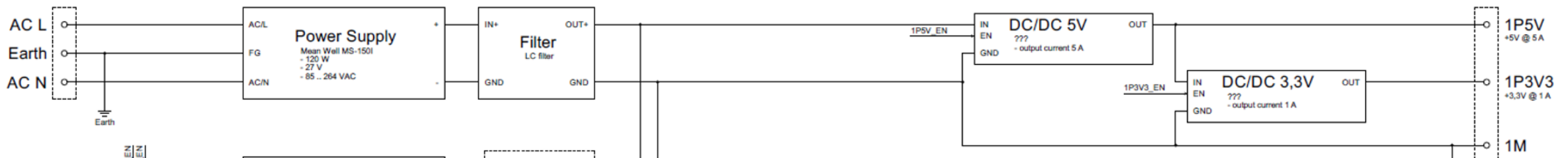
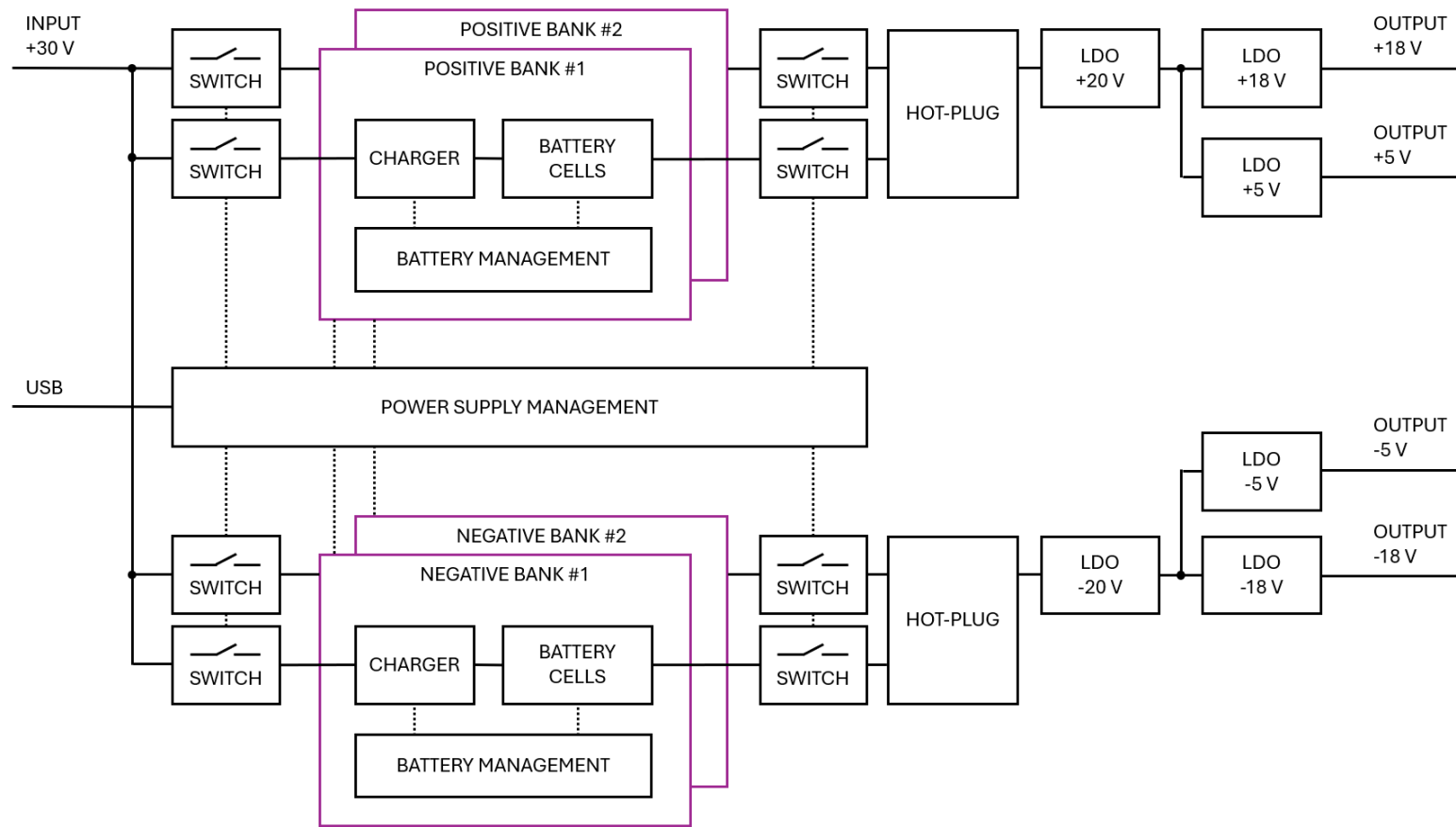

# Design

## Geometry

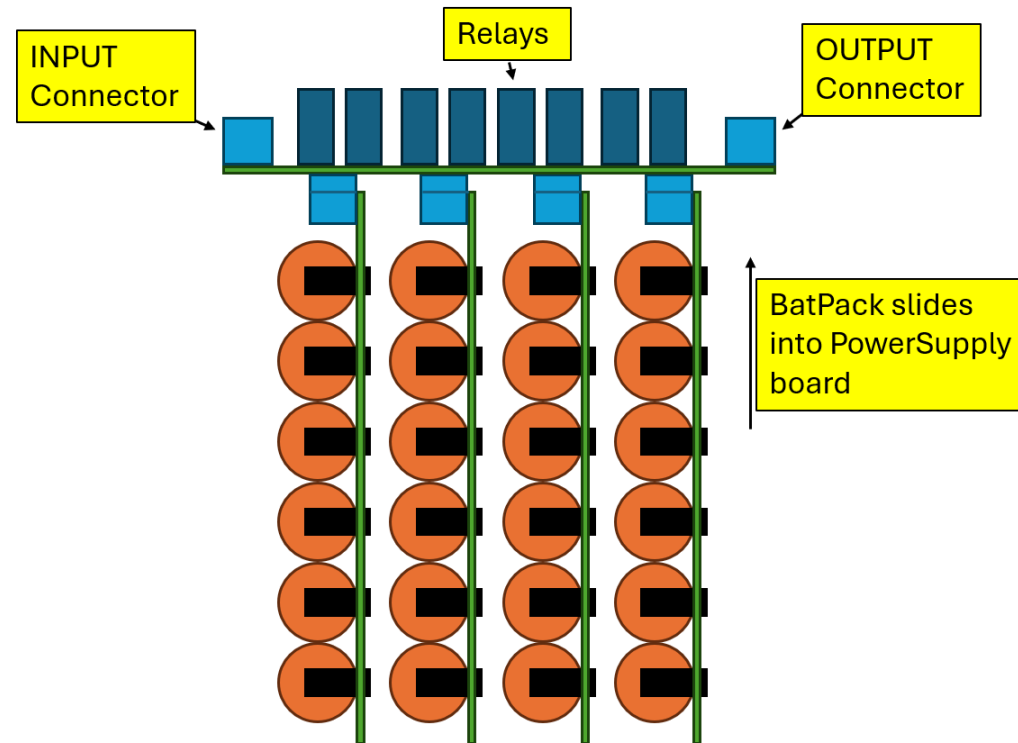
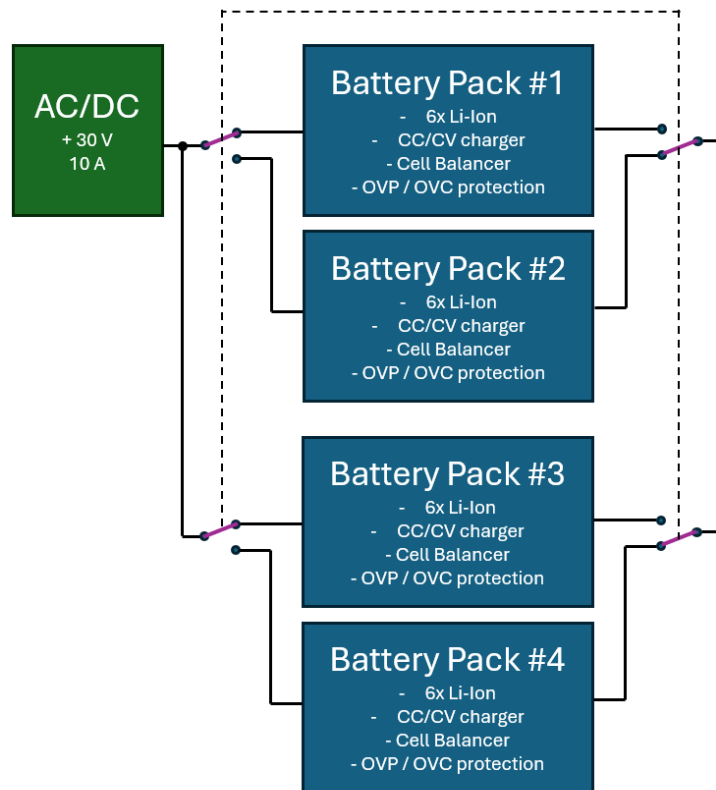

# Design

Isolation concept: set of relays in series and defined isolation barrier on the PCB

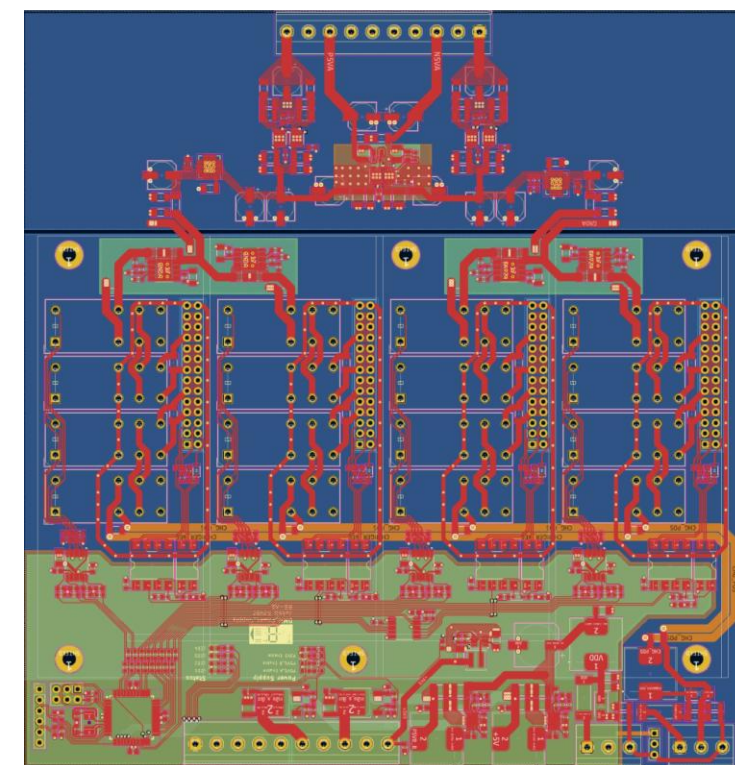
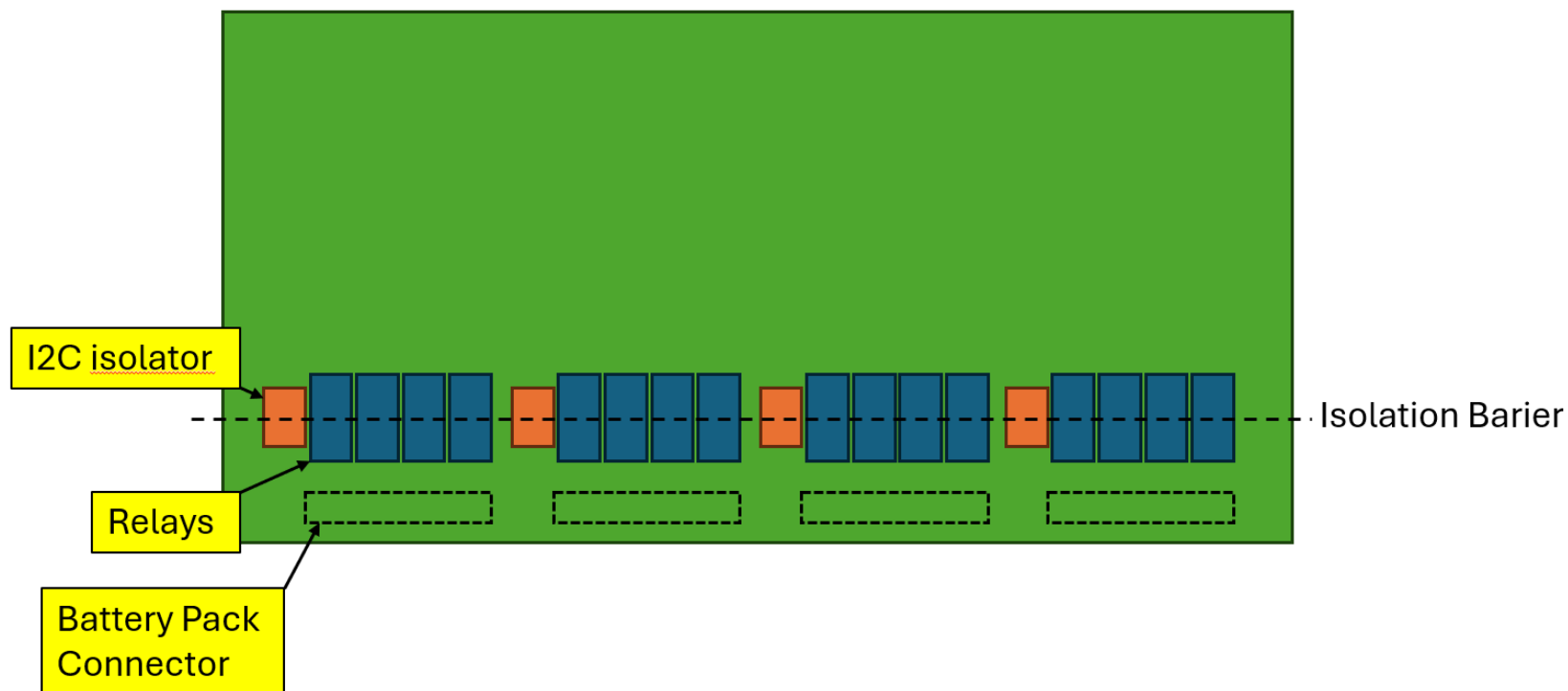

# Fabrication

From the model to the table...

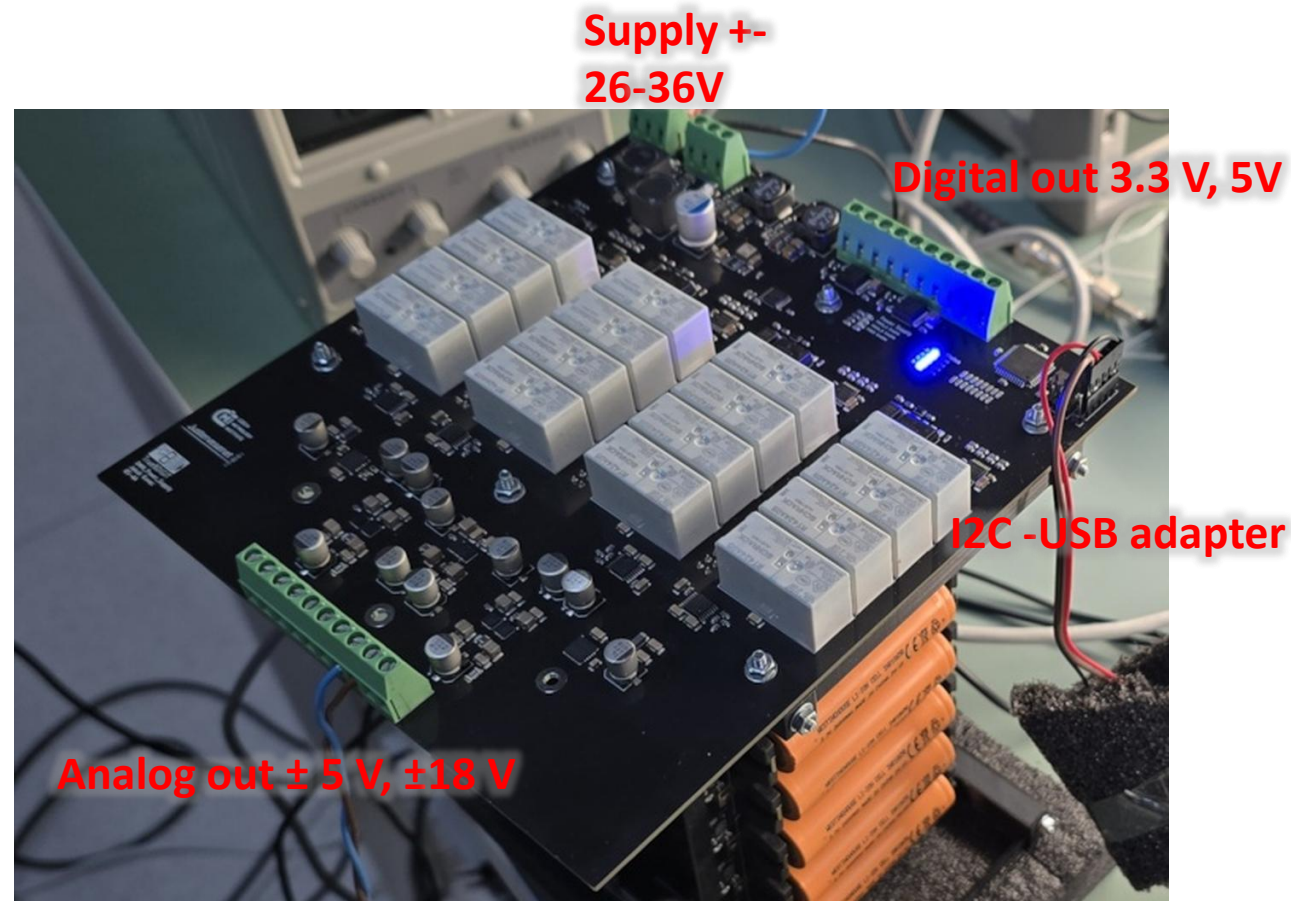
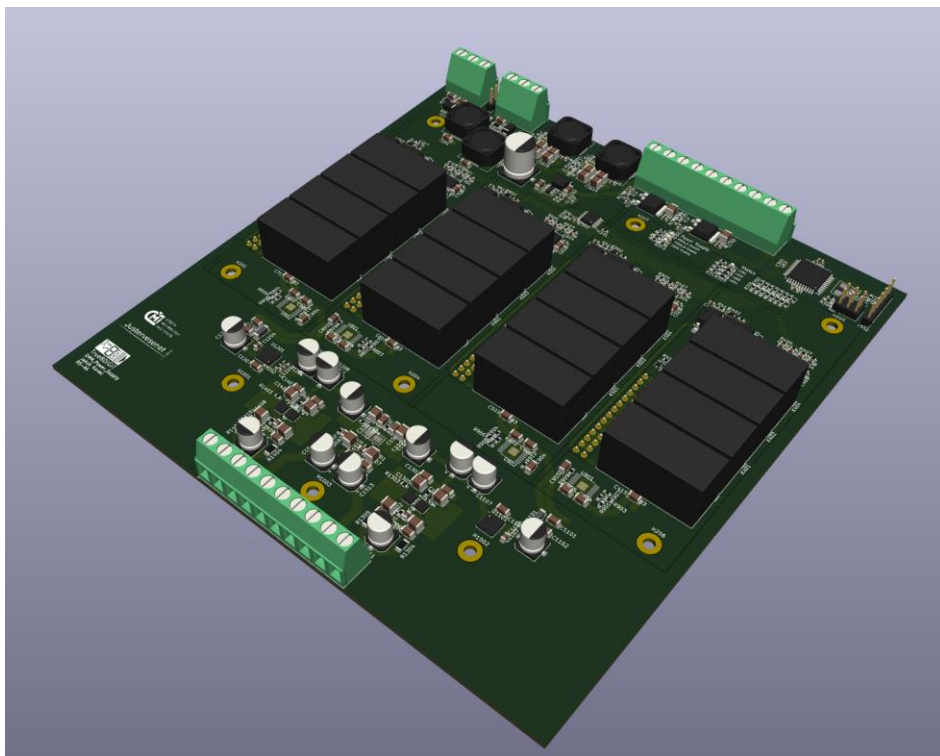

# Fabrication

A dedicated sw *PSU control* for characterization. Otherwise PSU runs autonomously.

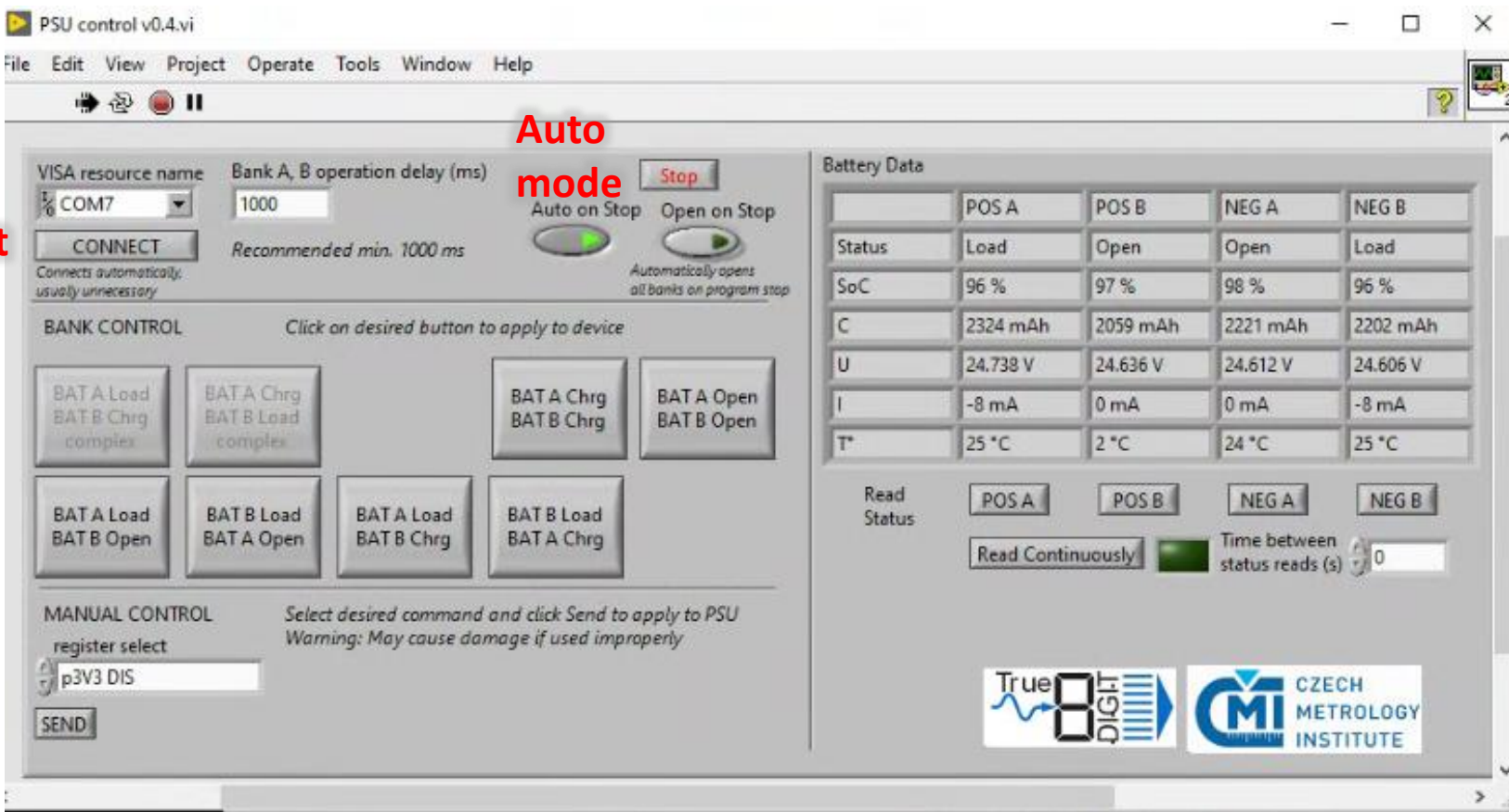

**Connect**

**Auto mode**

**Manual control**

**Batt status**

	POS A	POS B	NEG A	NEG B
Status	Load	Open	Open	Load
SoC	96 %	97 %	98 %	96 %
C	2324 mAh	2059 mAh	2221 mAh	2202 mAh
U	24.738 V	24.636 V	24.612 V	24.606 V
I	-8 mA	0 mA	0 mA	-8 mA
T*	25 °C	2 °C	24 °C	25 °C

# Characterization

- **Stability tests**
- **Temperature dependency**
- **Load dependency**
- **Isolation tests**
- **Noise tests**

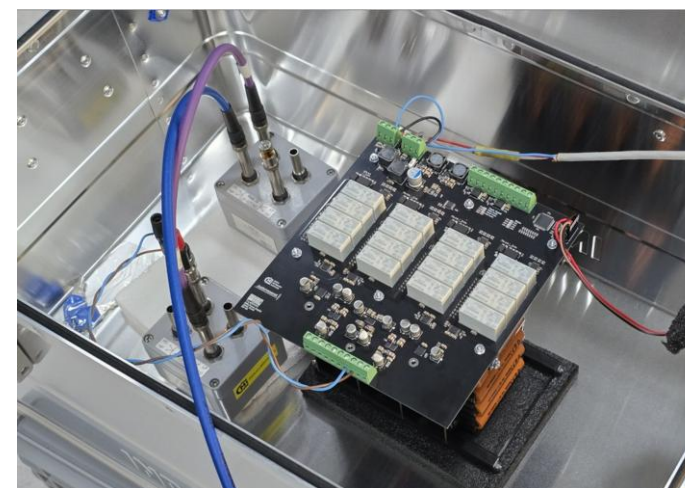
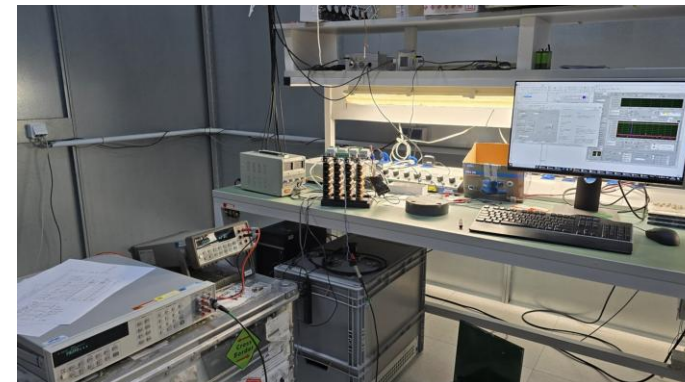

# Characterization

## Stability tests

Stability of DMM checked with a 10 V Zener-based standard

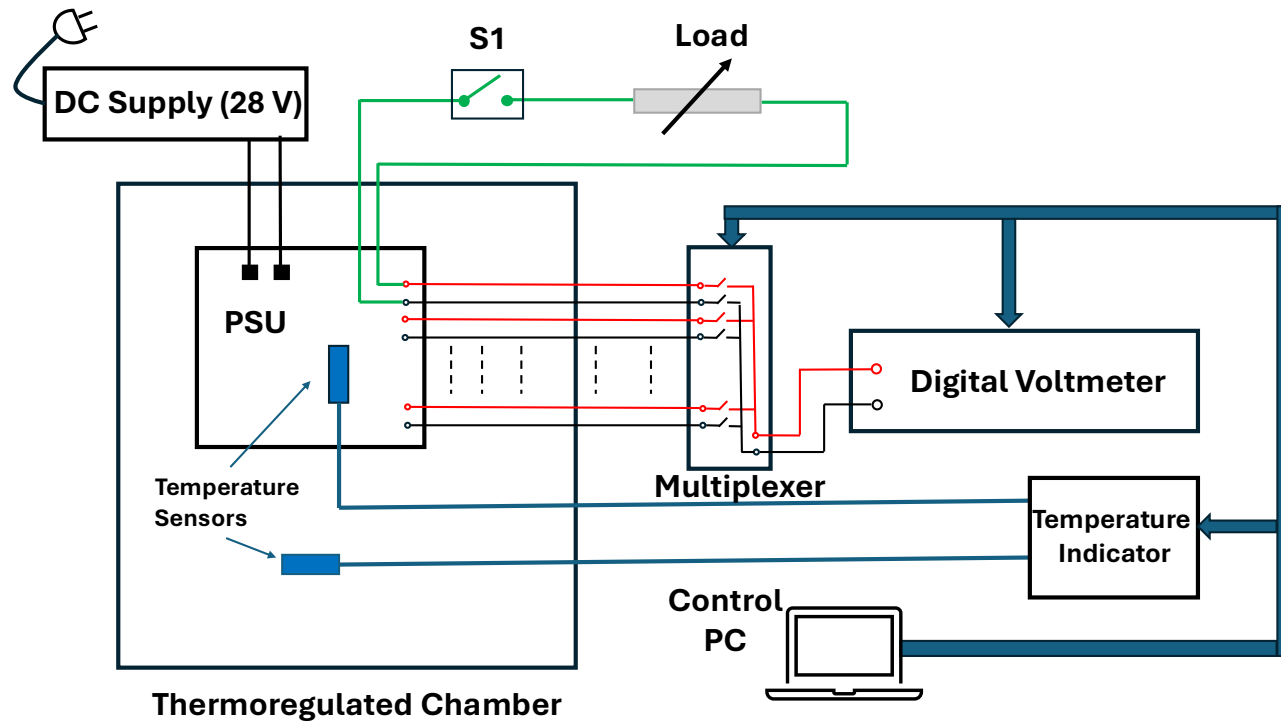

GUARDED



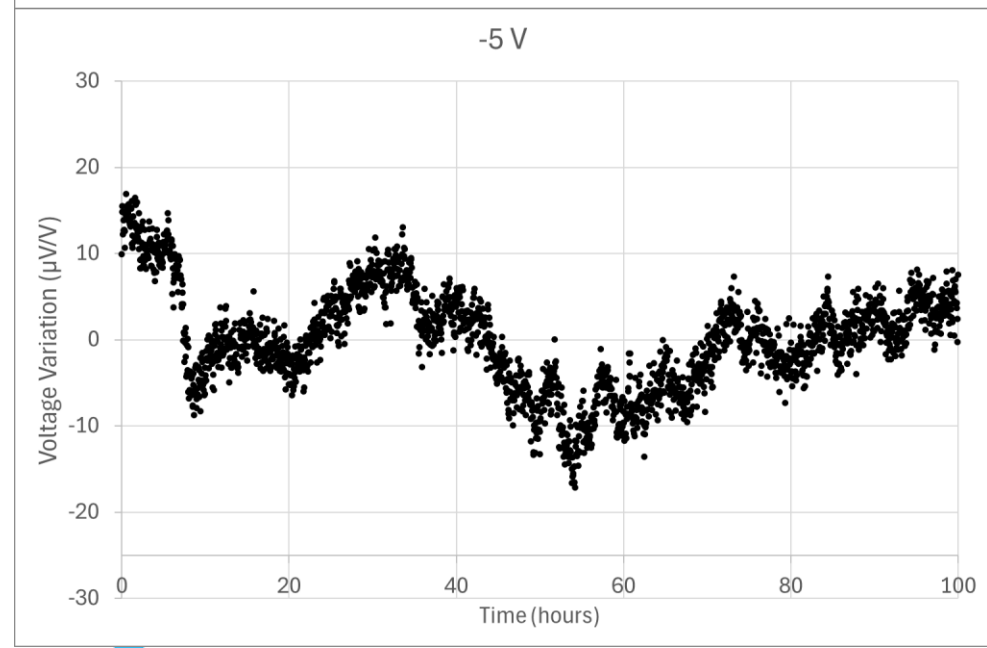
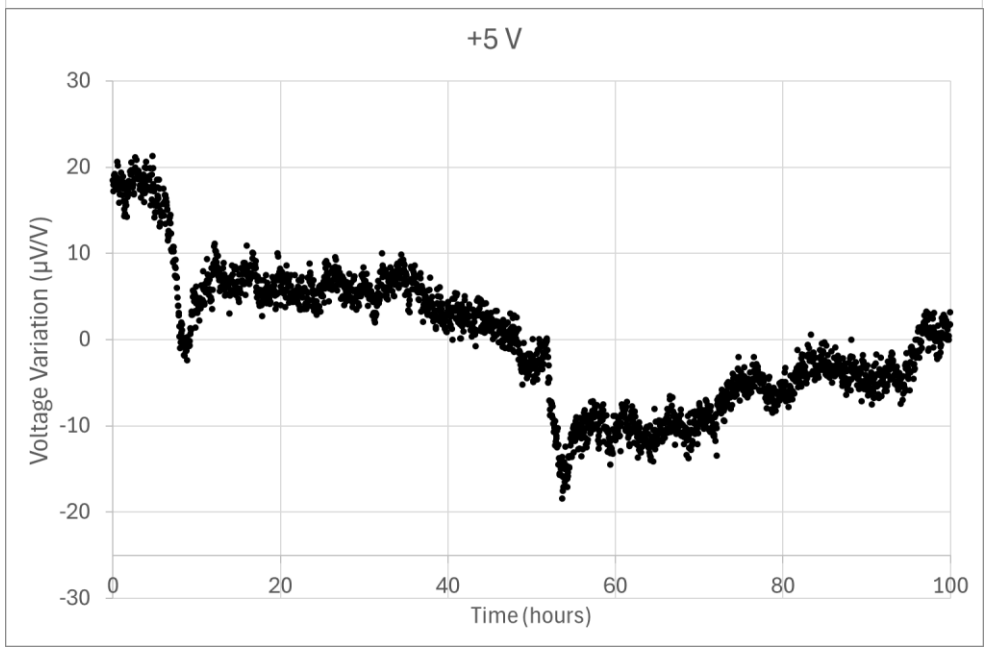
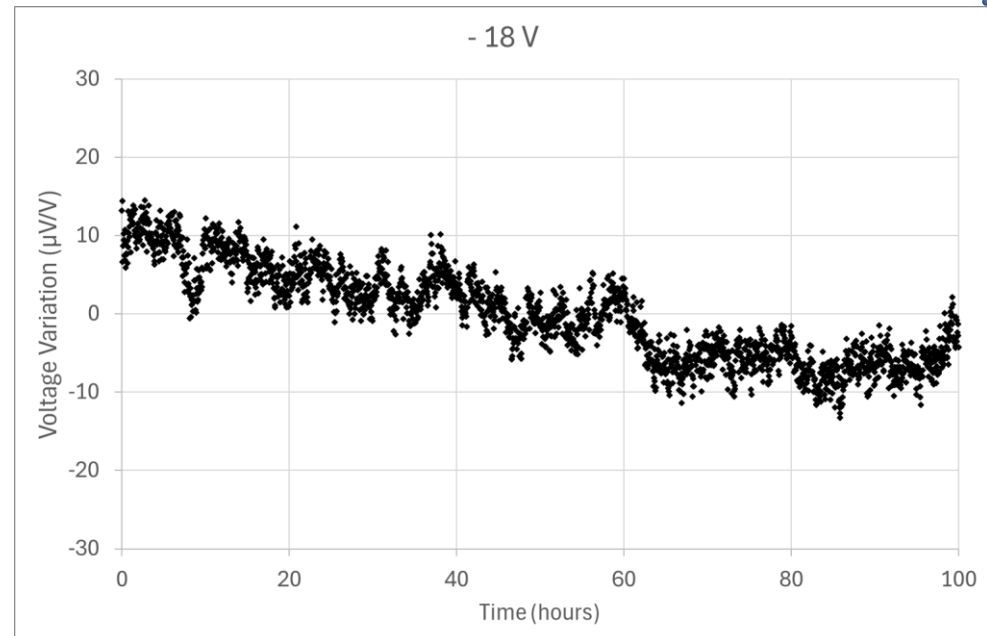
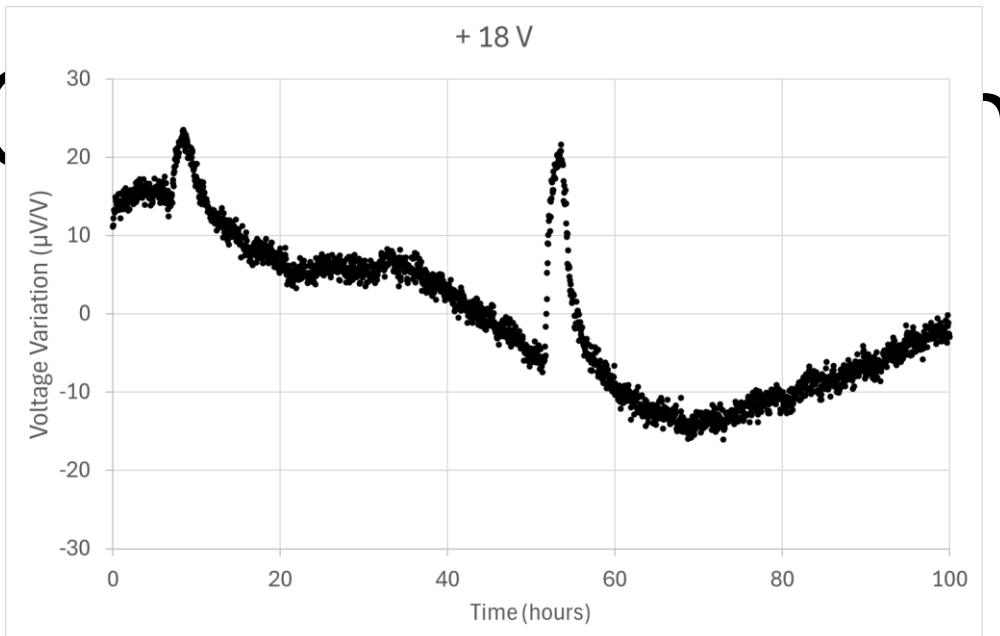

# Characterization

## Temperature coefficient tests

Intended Use	Nominal Voltage	Relative Temperature Coefficient
		( $\mu\text{V}/\text{V}$ per $^{\circ}\text{C}$ )
Analog	+18 V	+13
Analog	-18 V	-3
Analog	+5 V	-11
Analog	-5 V	-7
Digital	+5 V (#1)	+16
Digital	+5 V (#2)	+34
Digital	+3.3 V	-178

# Characterization

## Loading tests

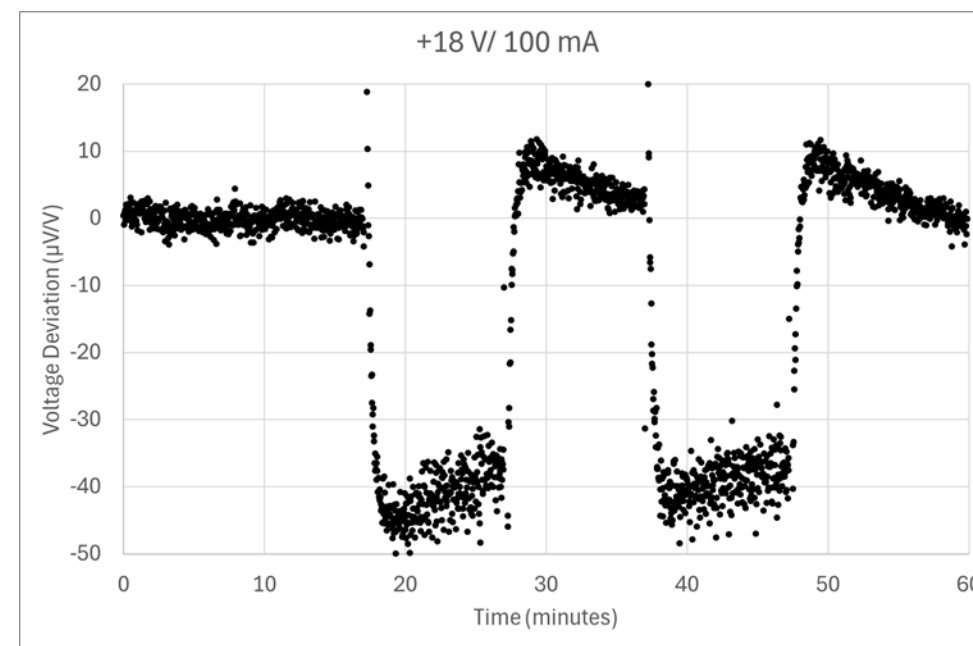
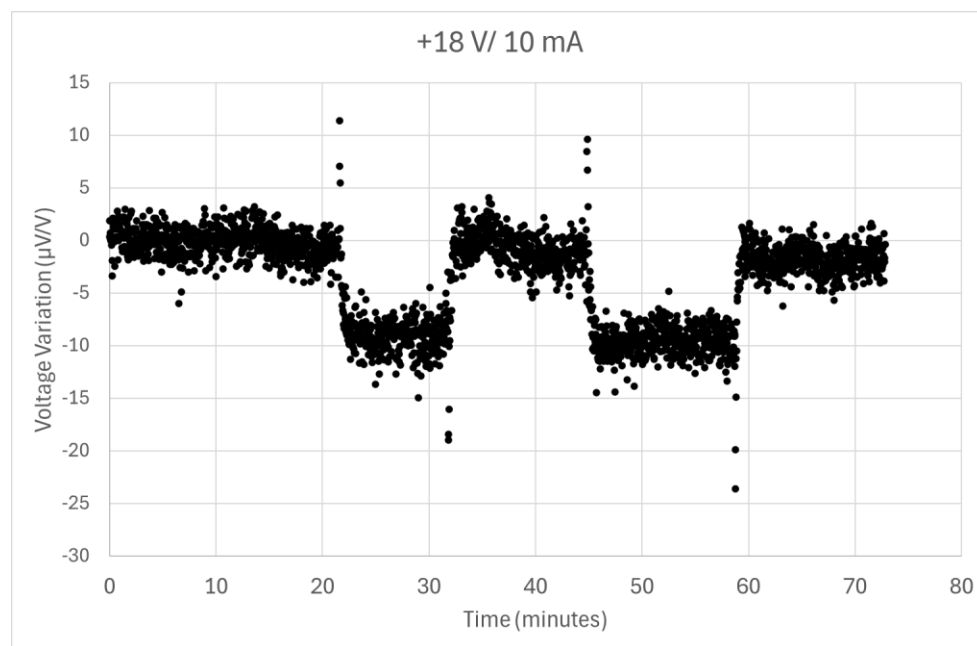

Output impedance 8-40 m $\Omega$  across  $\pm 18$  V and  $\pm 5$  V rails

# Characterization

## Isolation properties

Tested at 53 Hz with an injected disturbing signal at DC input of PSU.

Isolation levels independent on the battery configurations.

Outputs designed for high isolation have at least -106 dB isolation level.

Additional tests at other lab indicates achievable isolation at +18 V rail up to -145 dB @56 Hz, resp. -76 dB@1 kHz

Output	Isolation
3.3 V Digital	33
5 V Digital #1	322
5 V Digital #2	338
-5 V Analogue	>200.000
+18 V Analogue	>200.000
-18 V Analogue	>200.000
+5 V Analogue	>200.000

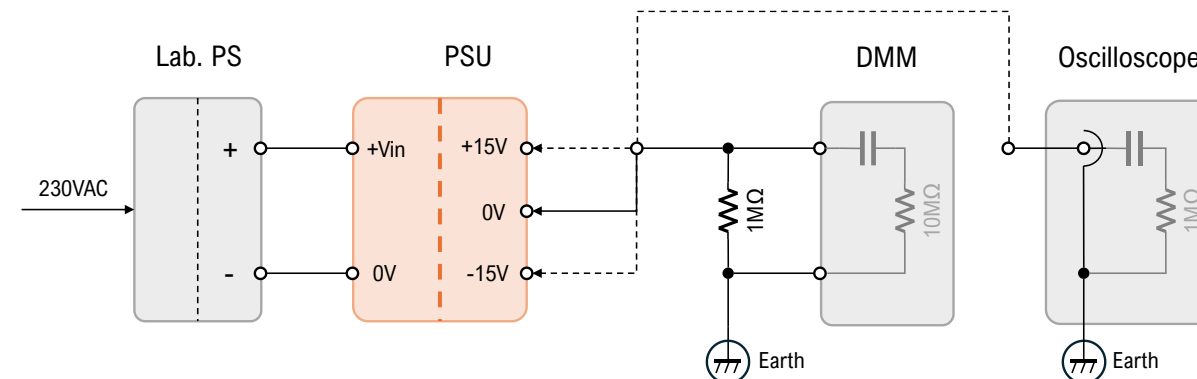

# Characterization

## Noise levels

First noise characterization with spectrum analyzers indicates that the noise level at 1 kHz is at the same level as the analyser's noise floor (approx. -140 dBV RMS). Further investigation is planned, together with lowering pickup of 50 Hz signals from surrounding.

# Conclusion



- Fully isolated power supply designed for low-level signals and high-resolution ADC applications
- Precision output rails  $\pm 18$  V,  $\pm 5$  V (analog),  $2 \times 5$  V and 3.3 V (digital)
- Galvanic isolation for noise and interference reduction
- Advanced battery management for reliable and efficient operation
- Stable, low-noise outputs with continuous operation capability
- Excellent thermal and load stability (low coefficients)
- Redundant battery architecture enabling seamless continuous run and extended lifetime
- Robust, high-reliability solution for demanding scientific and measurement systems

# Acknowledgement

Development and characterisation:



## FUNDING:

The project 22RPT02 True8DIGIT has received funding for the European Partnership on Metrology. Co-financed from the European Union's Horizon Europe Research and Innovation programme and by the Participating States. The UK participant in Horizon Europe Project 22RPT02 True8DIGIT is supported by UKRI grant number 10,084,012 (Signal Conversion Ltd).