

Bridge to measure distortion of resistors

Project Final Workshop
22RPT02 – *True8DIGIT*

Towards a true 8-digit digitiser

<https://true8digit.eu>

Rado Lapuh, Left Right s.p.
15th May 2026



Introduction – aims

- Live demonstration using QA403
- Bridge operation
- Resistor nonlinearity results
- Further development

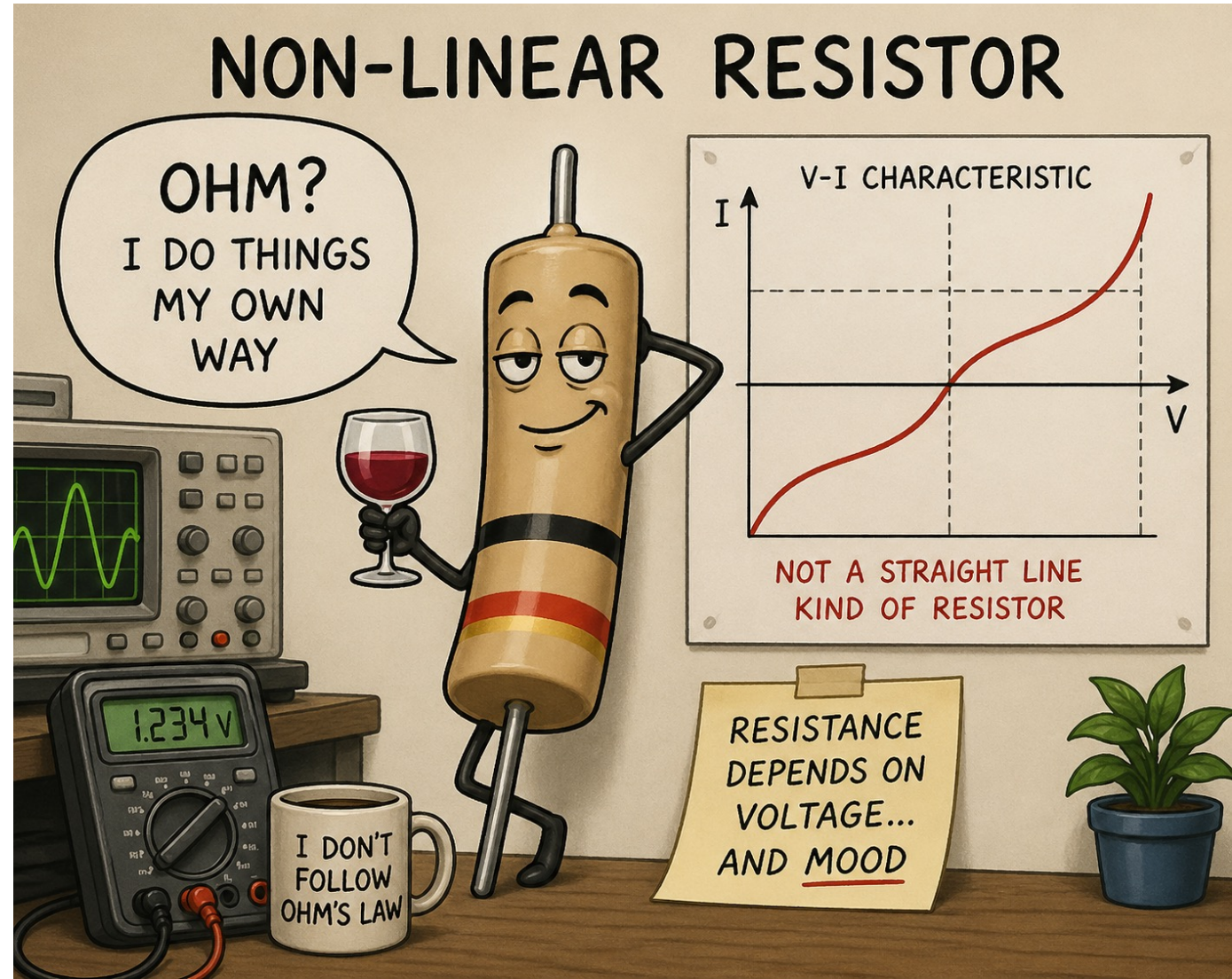

Measuring R nonlinearity - live



Are precision resistors really linear?

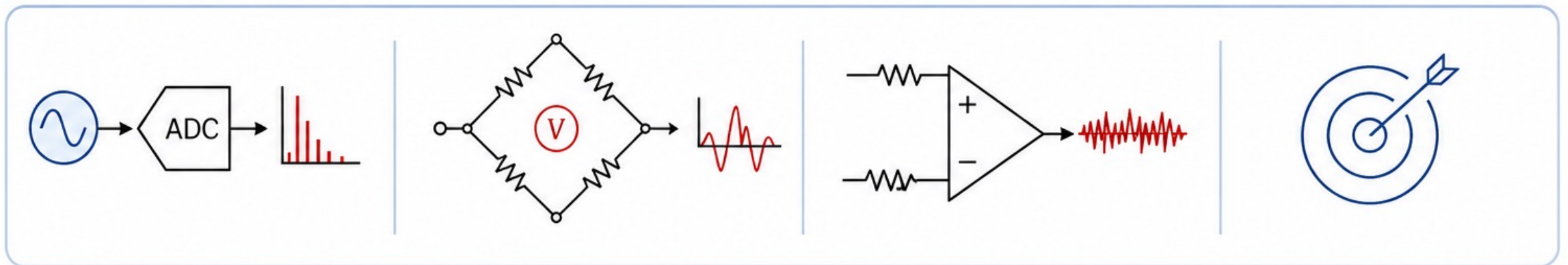
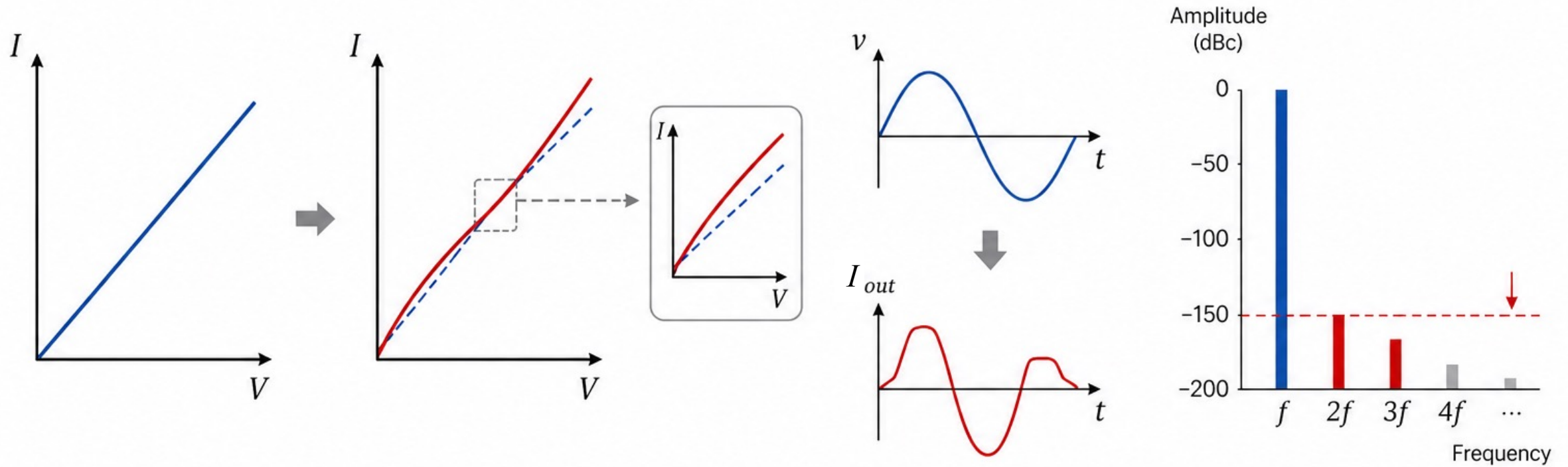

What resistor nonlinearity means physically

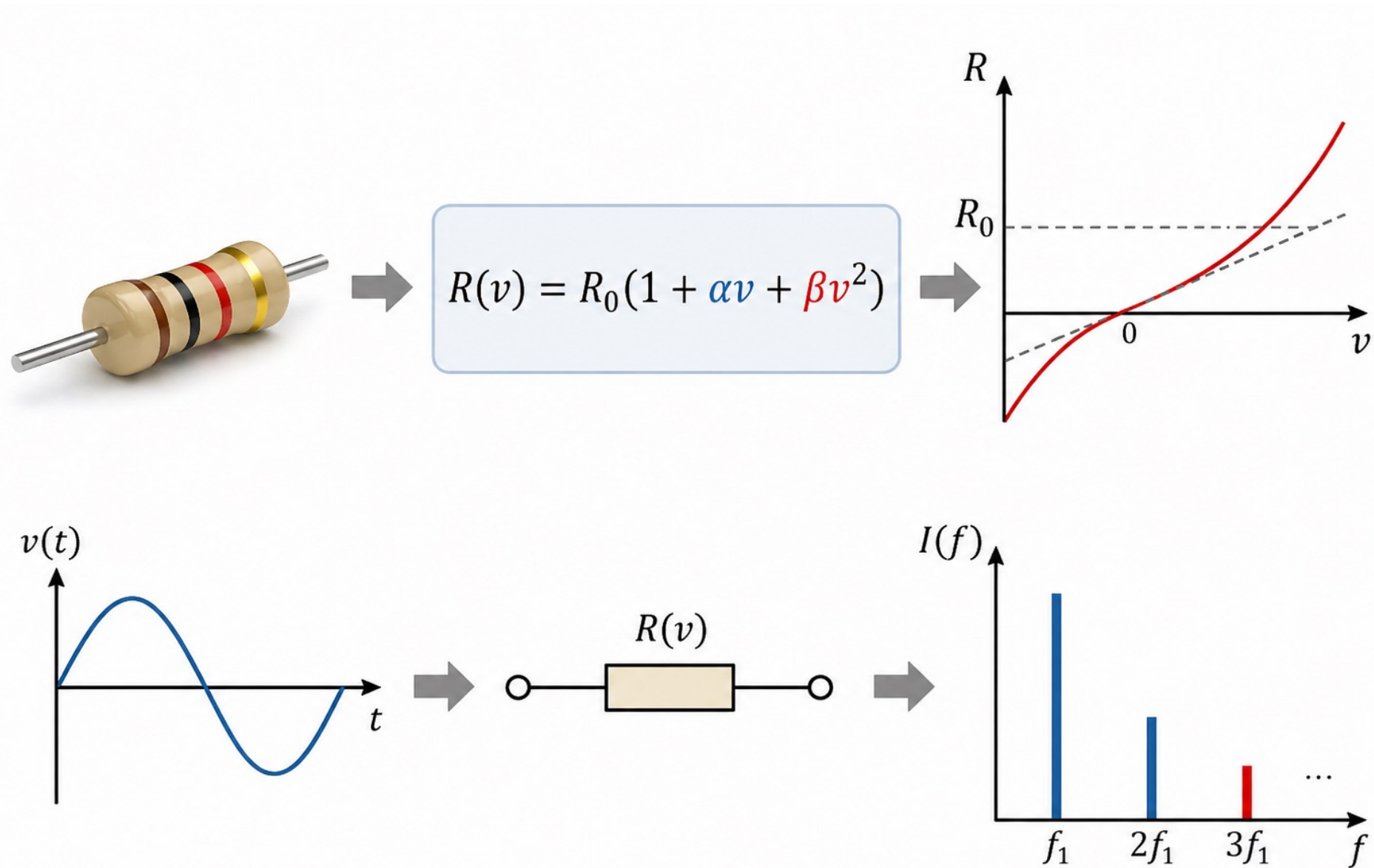

Why direct measurement is difficult

I'M VERY LINEAR... BUT **NOT** PERFECT!

REAL (NONLINEAR) RESISTOR
 $R(v) = R_0(1 + \alpha v + \beta v^2)$



sine excitation to measurement instrument

I CAN ONLY SEE WITHIN MY DYNAMIC RANGE!

TYPICAL INSTRUMENT DYNAMIC RANGE
~130 dB
(RESIDUAL / NOISE FLOOR LIMIT)

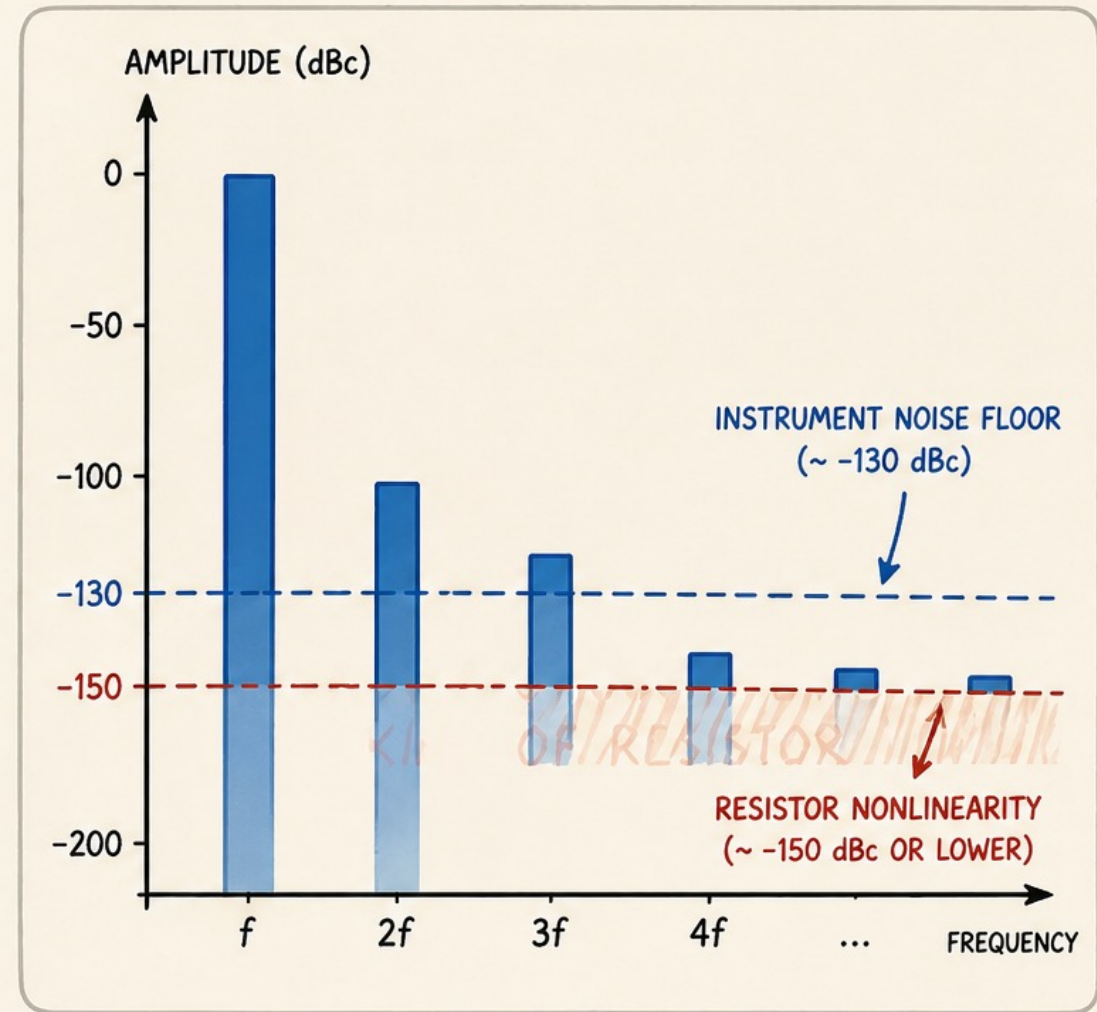
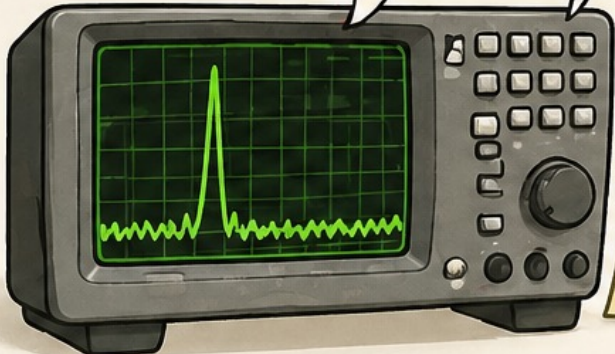

 THE HARMONICS FROM THE RESISTOR ARE AT OR BELOW -150 dBc - BURIED BELOW THE INSTRUMENT NOISE FLOOR.
THE INSTRUMENT MEASURES ITSELF, NOT THE RESISTOR.

Bridge method: the key idea

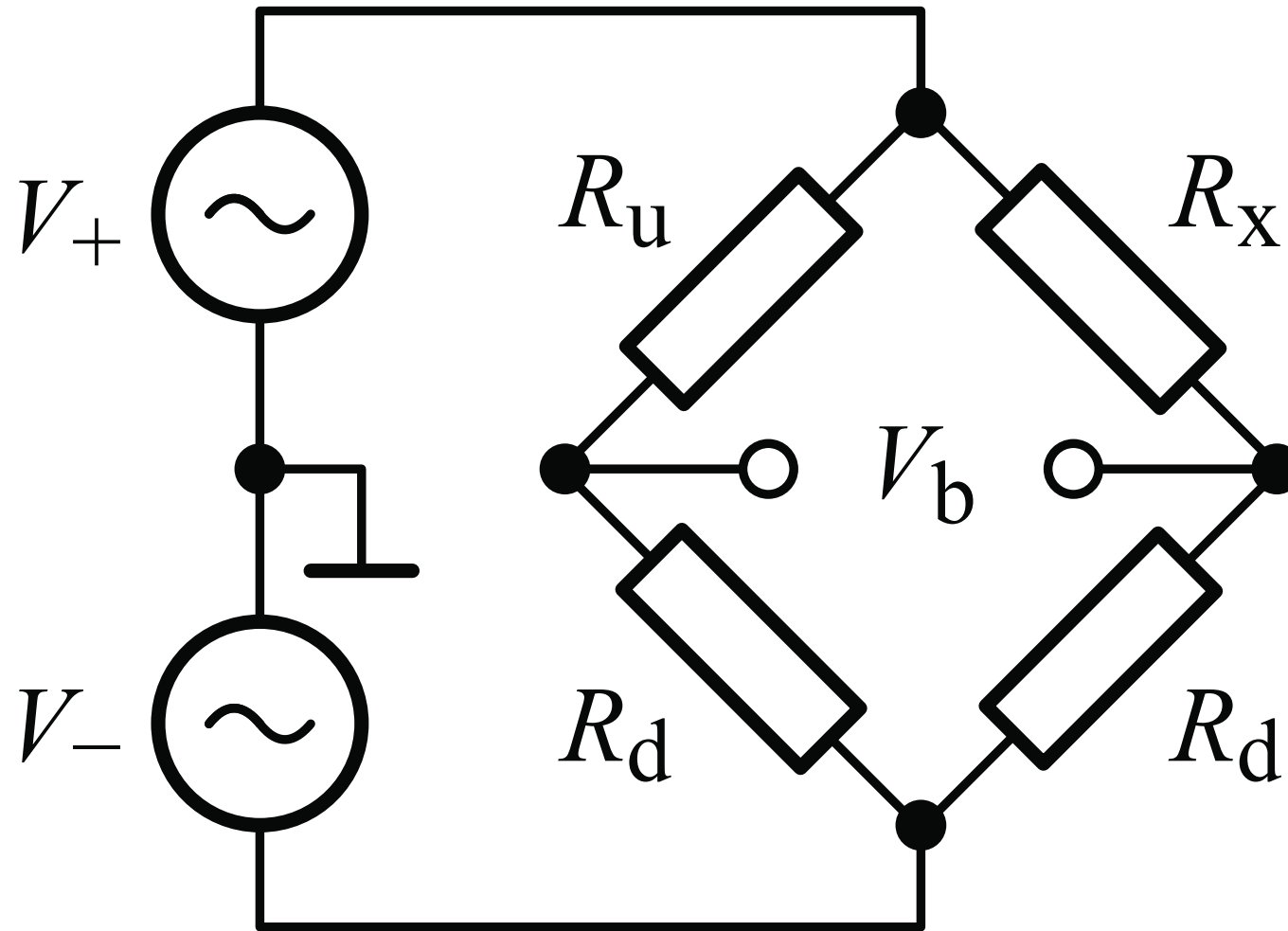

Our modified bridge solution

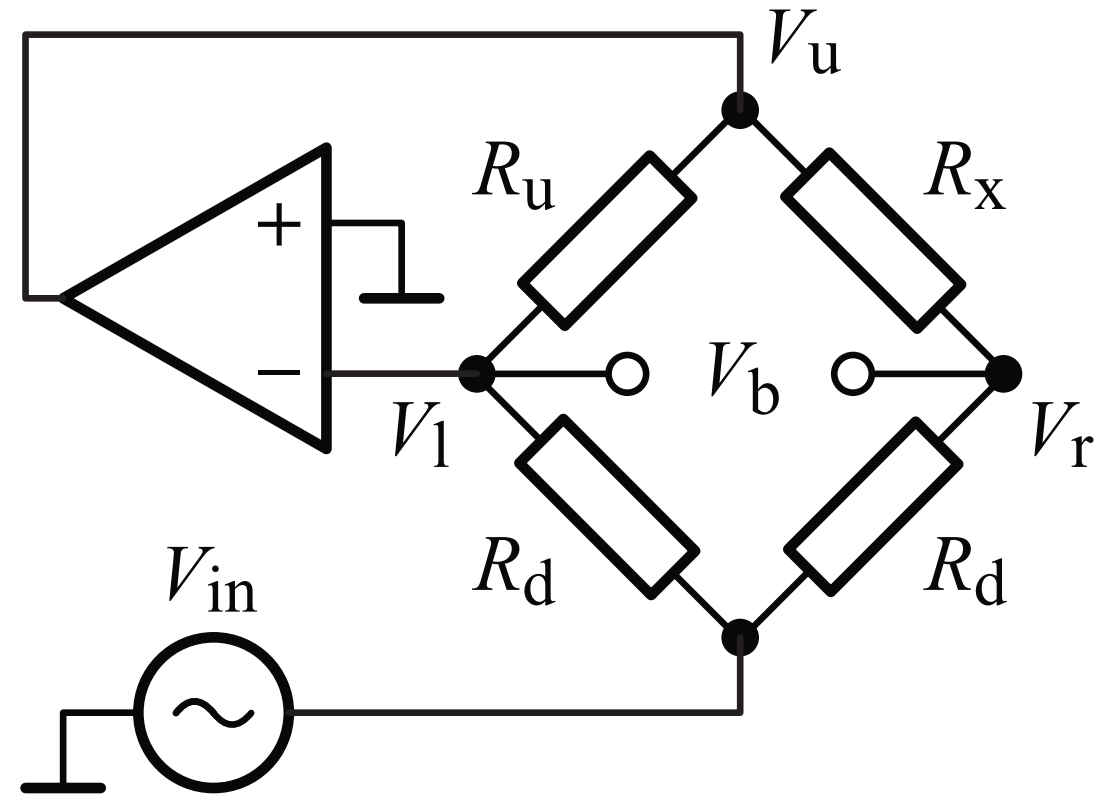
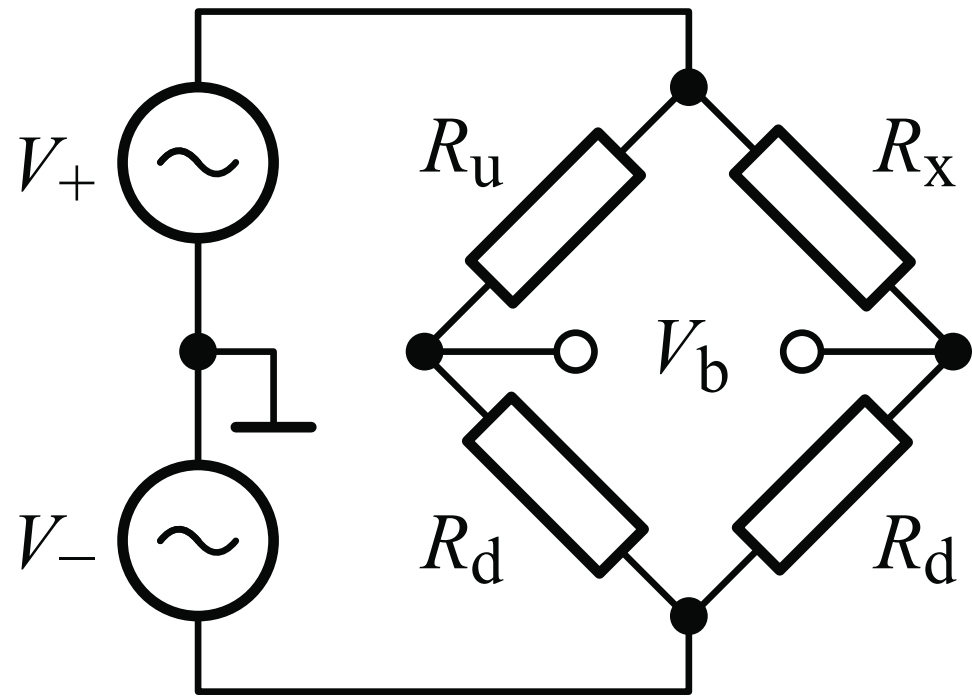

Measurement principle

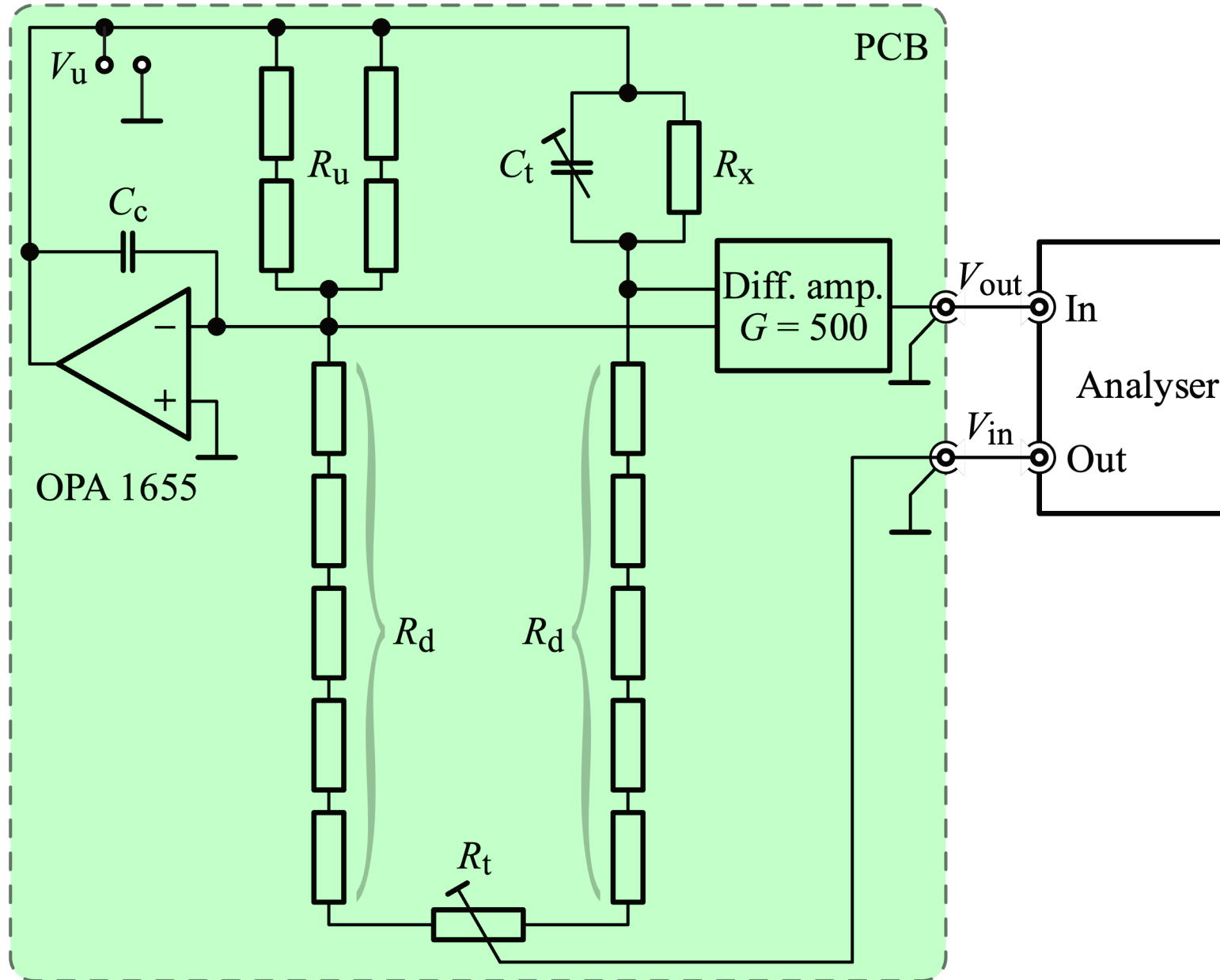

Measurement principle

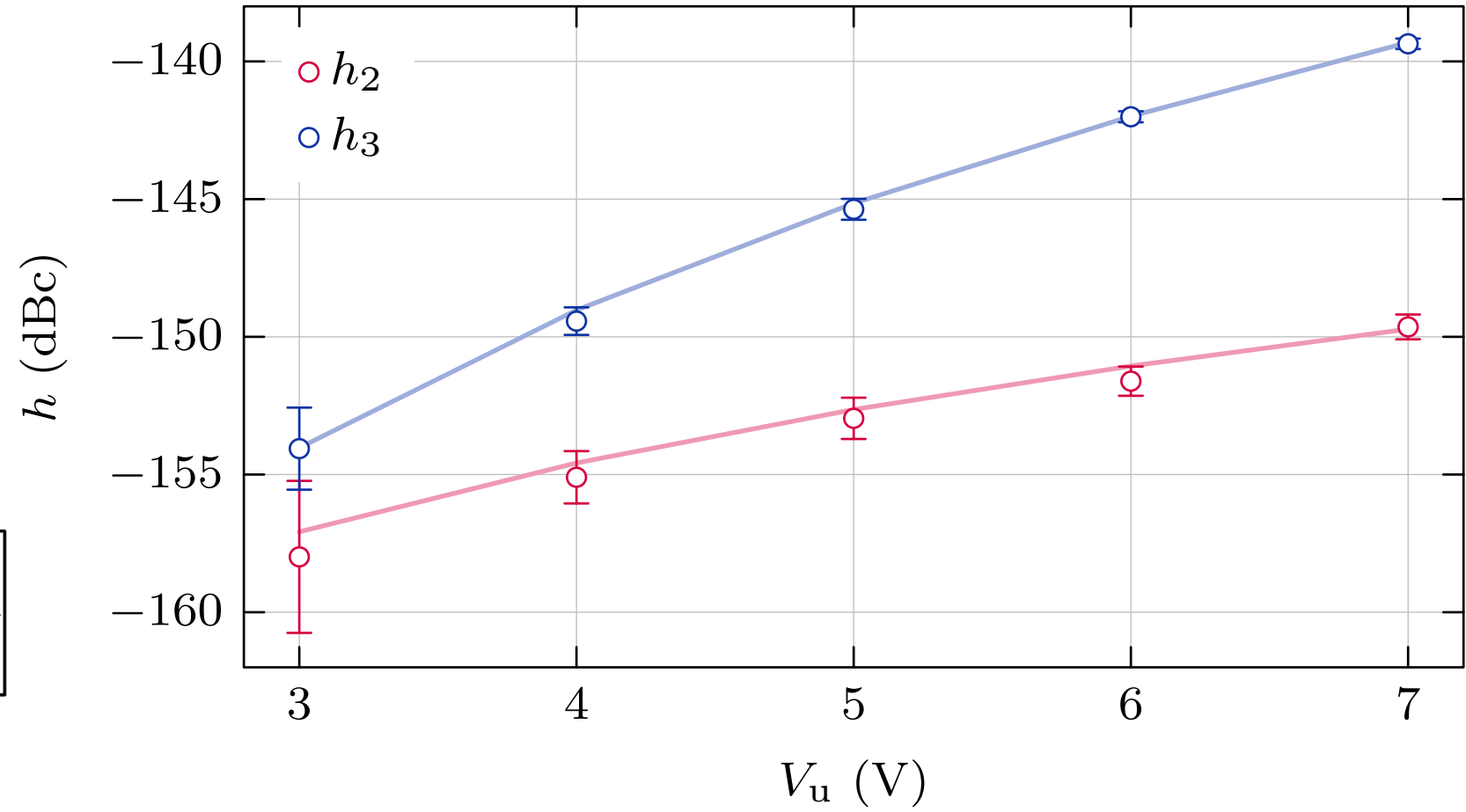
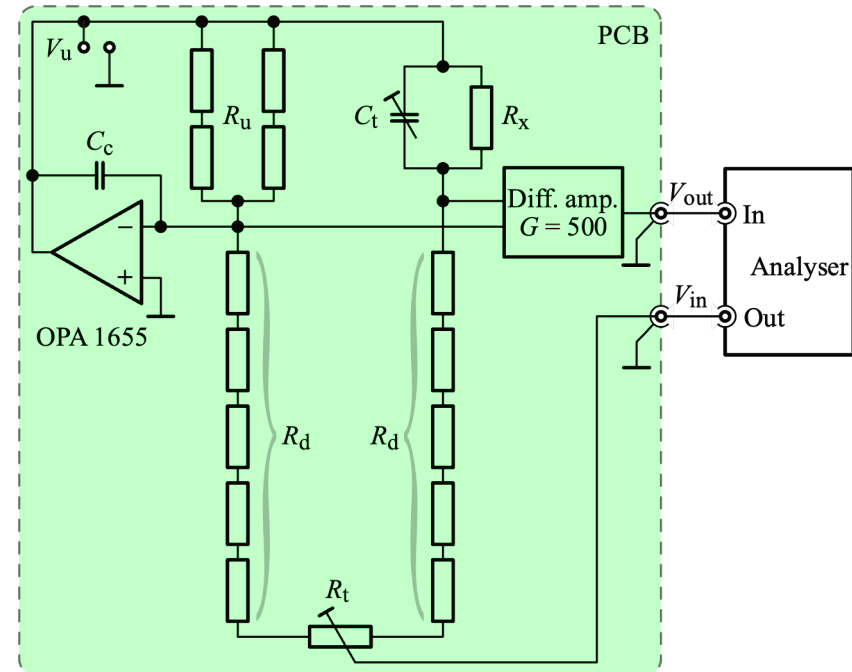

Live demo



Example results across resistor technologies

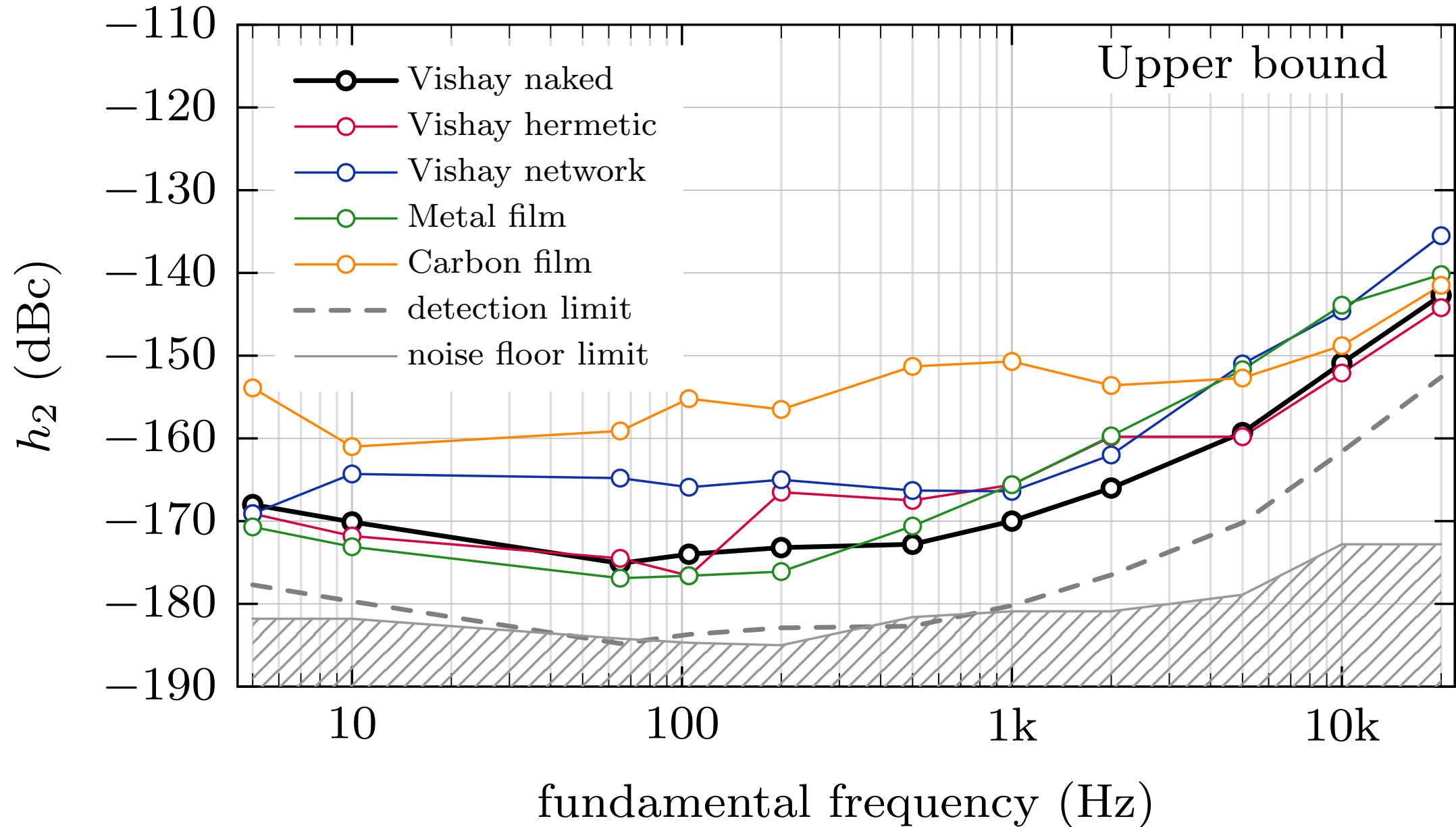

Example results across resistor technologies

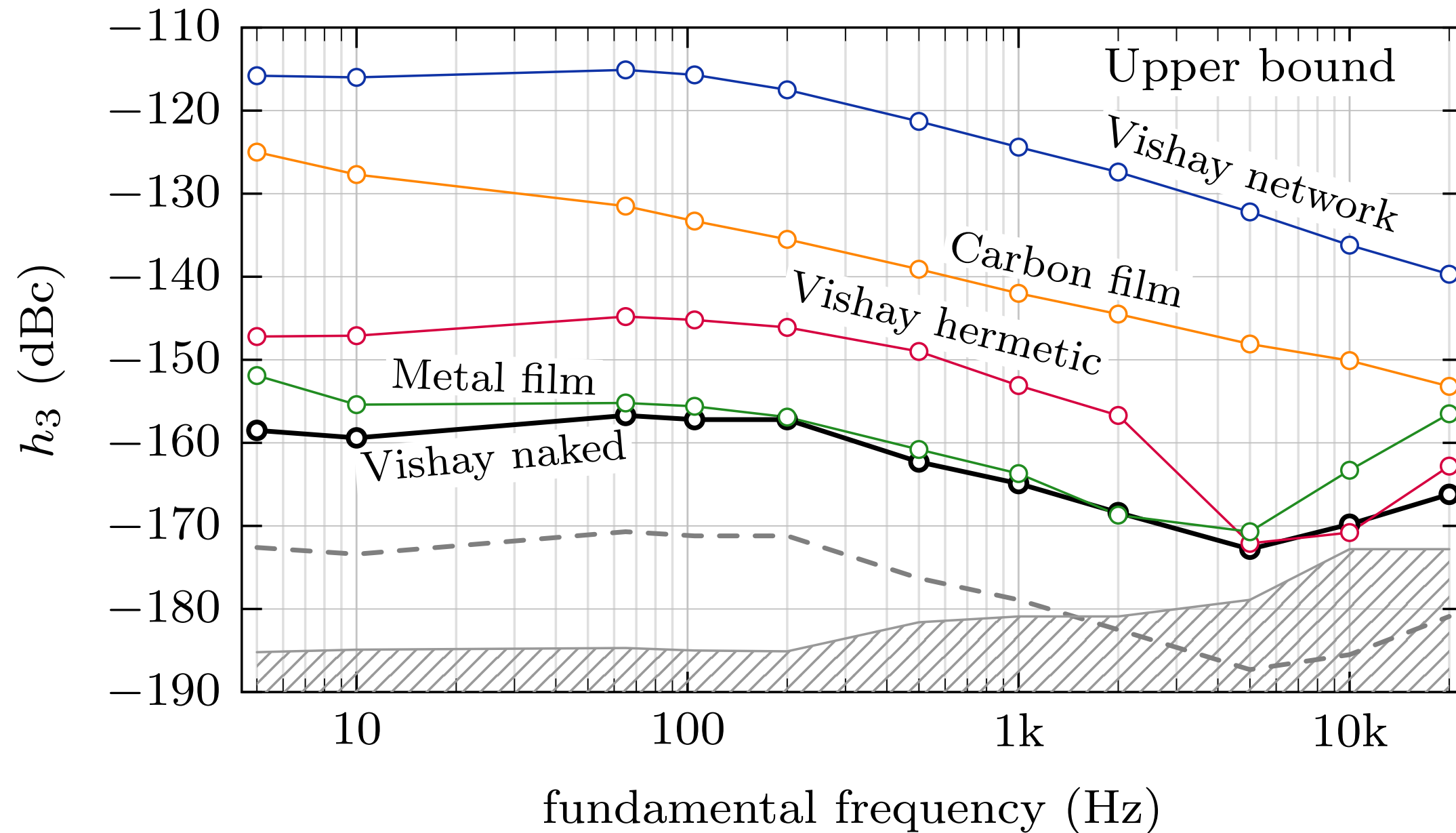

Example results across resistor technologies



V. Janásek, R. Lapuh, L. Palafox, N. Beev and B. Voljč

A Modified Wheatstone Bridge for High-Precision Characterisation of Resistor Nonlinearity

accepted for publication in IEEE Trans. Instrum. Meas.

Example results across resistor technologies



Bridge Characterization: Metal_Film_10k

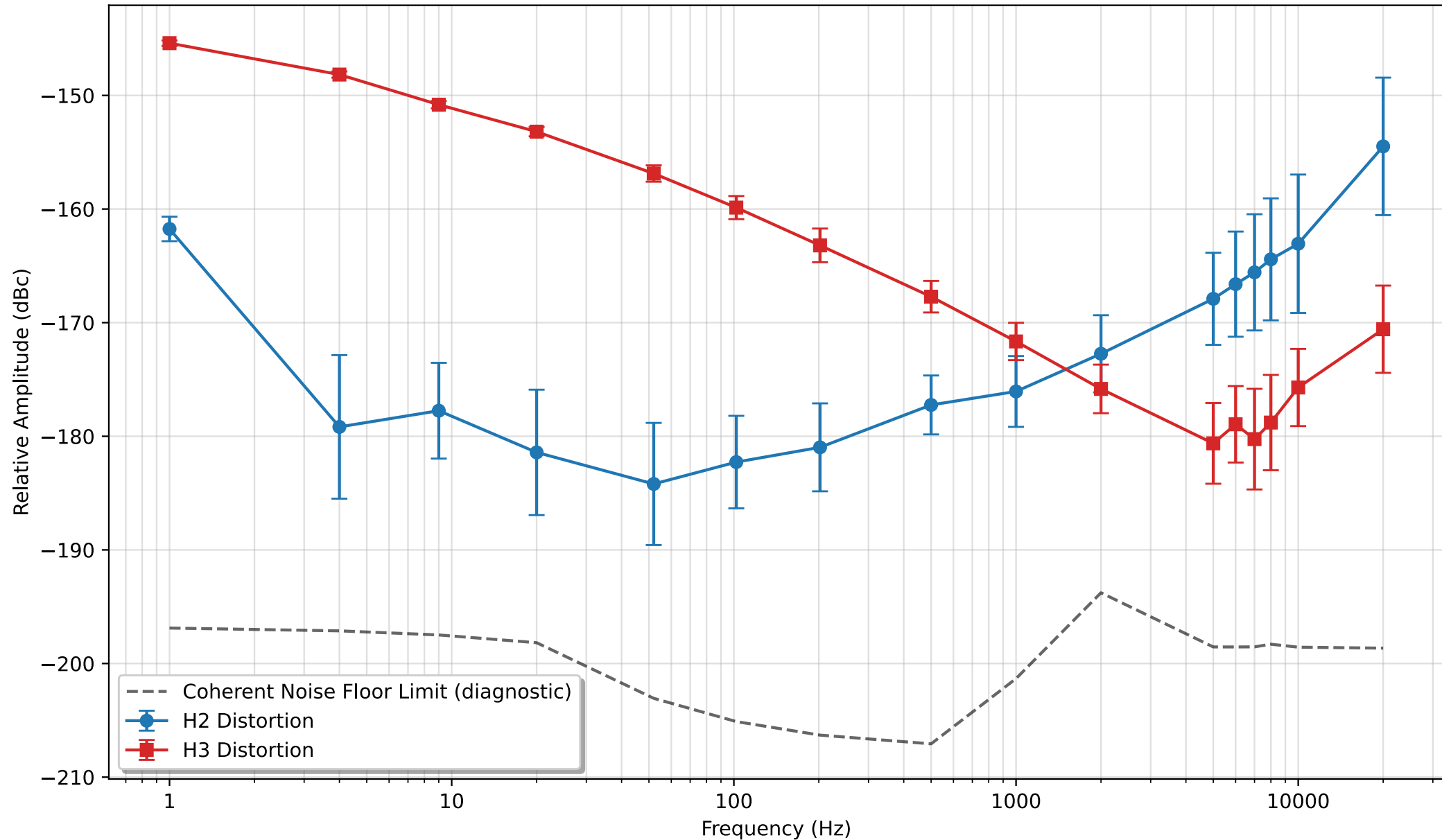

High sensitivity without exotic instruments

Bridge topology does the hard work – we just need good measurement practice.

NOT REQUIRED

Top-end ultra-low-distortion generators or analyzers



\$\$\$\$ Very expensive and not always available

SMART CIRCUIT, SIMPLE GEAR, GREAT RESULTS!

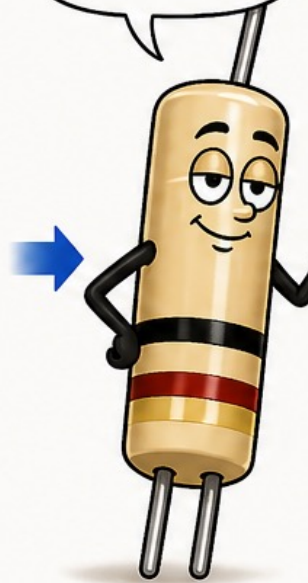

BRIDGE TOPOLOGY

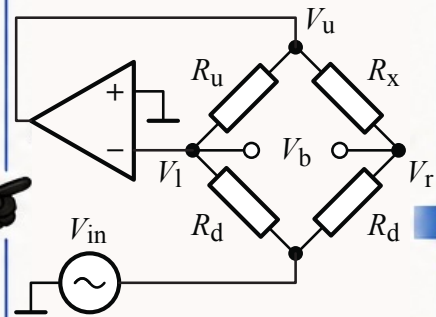

Carrier suppression + harmonic extraction

PRACTICAL SETUPS THAT WORK

1) BENCH GENERATOR + 10-BIT OSCILLOSCOPE

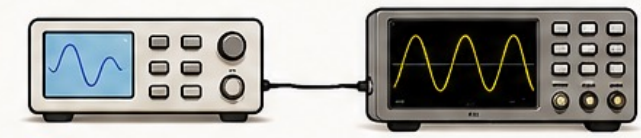

Usable measurements with averaging + uncertainty analysis

2) QA403-BASED SYSTEM



Even better sensitivity than shown before

3) PYTHON AUTOMATION & UNCERTAINTY SOFTWARE



Automated measurement, coherent averaging, full uncertainty budget



SOFTWARE WILL BE MADE PUBLICLY AVAILABLE

As a project outcome for the community.



HIGH-SENSITIVITY DISTORTION MEASUREMENTS WITH ACCESSIBLE EQUIPMENT.

Good circuit + good practice > exotic gear.

Thank you



This work was carried out as part of the True8DIGIT project. The project 22RPT02 True8DIGIT has received funding for the European Partnership on Metrology co-financed from the European Unions' Horizon Europe Research and Innovation programme and by the Participating States. The UK participant in Horizon Europe Project 22RPT02 True8DIGIT is supported by UKRI grant number 10,084,012 (Signal Conversion Ltd).