

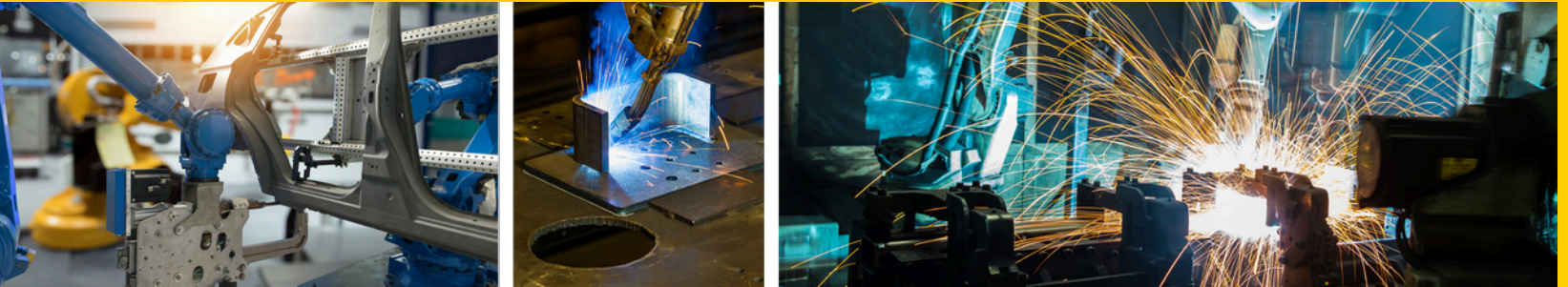

TURCK



Sensors Catalog

Welding Solutions

A Global Leader in Industrial Automation

Turck's sensors, connectivity, and fieldbus technology products are built to be the best. As one of the most **prominent** sensor manufacturers **in the world**, we even back our sensors with a **lifetime warranty**. Turck works by bringing **rugged engineering** solutions to your industrial automation applications.

85,000+
SOLUTIONS

50+
YEARS OF INNOVATION

2,000+
EXPERIENCED SALES REPRESENTATIVES

Pioneer in non-contact

sensing technology

Developed innovative connectivity solutions in response to our customers' needs

Recognized the need for advanced I/O solutions in harsh duty environments

**SUPPORT &
DEDICATED SERVICE**

EXTENSIVE WARRANTY

4,000+
APPLICATION EXPERTS

RESPOND and SOLVE over **1,200** inquiries per day



Strategically placed manufacturing facilities in the

USA with **28** GLOBAL SUBSIDIARIES

GLOBAL BUT LOCAL...

60 representations worldwide

Solutions for Welding Environments

Proximity sensors in welding environments are damaged and destroyed for a variety of reasons, including molten metal slag from MIG/TIG welding and weld spatter from resistance (spot) welding. To help our customers increase productivity in weld cells, Turck offers specialty sensors and cordsets to withstand the high heat and rigors associated with this harsh environments.

Weld slag and spatter are not the only factors that can harm sensors in these locations. Sensors are exposed to physical damage caused by either physical impact or abrasion from the target that is being sensed. Continuously exerting this kind of stress on a sensor will cause its internal electronics to fault and/or its exterior to break, leading to replacement.

Common proximity sensors are non-contact, meaning they do not need to touch the actual target to sense it. However, in many applications the physical target inadvertently does touch the sensor. Friction between the target rubbing against the sensor can cause the sensing face to wear and eventually lead to sensor failure. Turck has a solution for this also.

Turck's solution protects the sensor from impact and abrasion, extending its service life exponentially.

Above all, it is important to remember that every application is different, and no one solution will work to protect these components from every application hazard.

ENVIRONMENTS

- metal forming
- Automotive Manufacturing
- Pipe Construction
- Welding Cells
- MIG/TIG & Resistance Applications

SOLUTIONS

- product enhancements
- Sensor Coatings
- Protective Covers
- Cable Sleeving
- High Temperature Sensors



AUTOMOTIVE TIERS

We provide solutions for the fast-paced environment of the automotive manufacturing world. Tier suppliers depend on Turck for continuous uptime and rugged products that can withstand the harshest conditions.



WELDING/JOINING

Turck sensor technologies are key aspects of many general welding disciplines, including gas metal arc welding, resistance spot welding, capacity discharge, drawn arc, and laser welding.

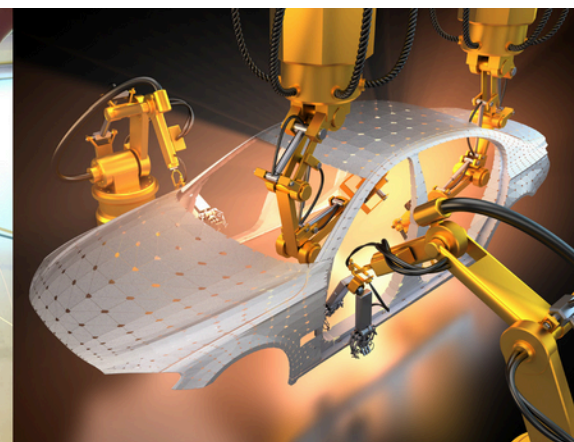

ROBOTIC WELDING

Leading companies in the Robotic Welding industry have chosen Turck as their solutions provider for both small scale and multi axis positioning cells. Our sensors, tool changers, and welding positioners are top of the line, and trusted like no other.

Sensors for Welding Environments

Weldguard

See page 11



Weldguard sensors use a proprietary material on the sensing face that is:

- Independently tested to over 25,000 operations without failure
- Impervious to weld spatter that creates pitting, chipping and cracking caused by resistance welding
- Superior replacement for any type of material used on a sensing face
- Able to withstand high heat
- Resistance to pitting chipping and crackling caused by molten metal traveling at high velocity

**weld
guard®**

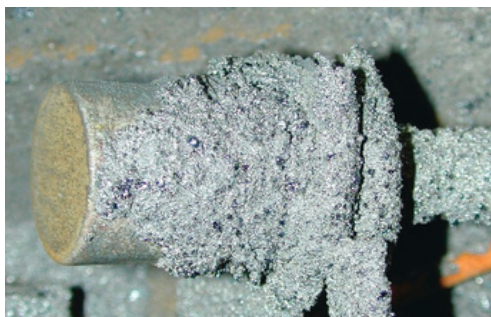
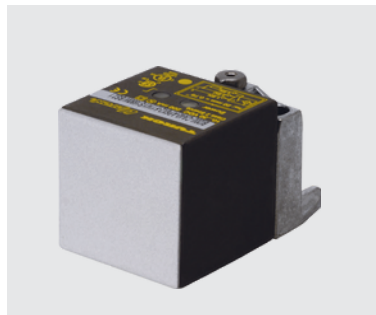

Competitors failed at less than 2,000 welds.
Turck Weldguard lasted 34,256 welds.



Turck Weldguard lasted 25,691 welds.

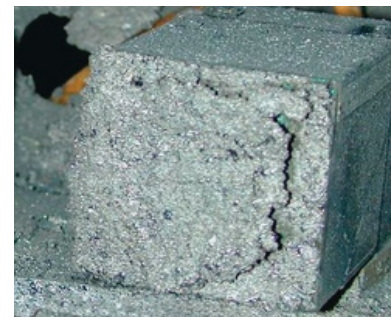

Competitors failed between 449 and 1,869 welds.

Sensors for Welding Environments

Armorguard

See page 51



Impact

Armorguard provides built-in durability that:

- Protects the sensor face from impact
- Can include Weldguard material on the sensing face to resist weld slag
- Extends the life of the sensor dramatically
- Available in 8, 12, 18 or 30 mm barrel diameters, as well as cube style sensors

**armor
guard**®



Armorguard Accessories:

- Turck's Armorguard sleeves are available as an accessory to the sensor to protect the sensing face from lateral impact when not in a direct weld environment.



Stainless Steel Front Face

See page 59

Turck's heavy-duty stainless steel construction:

- Protects the barrel and internal electronics from damage due to impact
- Protects the sensing face from damage due to abrasion
- Available with PTFE or Weldguard coating for protection against weld slag
- Has limited areas of entry, preventing oils and lubricants from seeping into the sensor
- Utilizes a one piece stainless steel housing
- Offers extended ranges



Impact



Abrasion



Resistance Welding



Stainless Steel Weldguard with PTFE coating



Stainless Steel



Stainless Steel

Sensors for Welding Environments

Stoneface

See page 71

Turck's Stoneface sensors use a glass filled thermoset plastic material on the sensing face that:



- protects the sensing face from abrasion
- is resistant to weld slag buildup that is often a result of MIG/TIG welding
- is available with PTFE coated barrels to shed weld slag

**stone
face®**

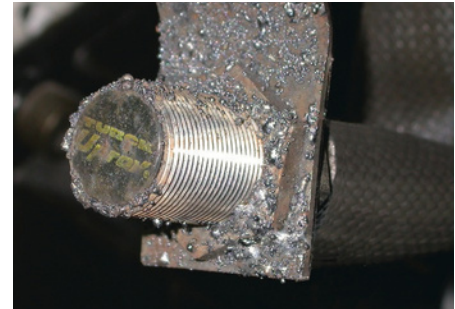

Nut Detection Sensors

See page 81

Turck's weld nut sensors provide efficient and economical detection of weld nuts in automotive applications:

- an economical alternative to more expensive optical or vision-based systems that often malfunction due to:
 - Dirt and weldplatter residue
 - Frequently changing lighting conditions in welding zones
- rugged construction delivers dependable performance
- TFE coated
- NiN coated
- simple programming
- bright LEDs indicate the output status



Instrumentation for Welding Environments

Flow Monitors for Weld Tip Protection

See page 86

Flow monitors are used in the welding industry to detect the loss of coolant to weld tips, preventing damage to equipment.

Probe Style Flow Monitors

- self contained
- fits standard plumbing tees
- stainless steel construction
- compact design allows mounting near weld tip

Inert Gas Flow Monitors

- verify presence of Argon, Helium and other MIG welding gases
- verify ventilation system is working in fume hoods



Pressure Sensors for Weld Cell Monitoring

See page 88

High Accuracy Pressure Sensors

- hydraulic system monitoring
- pneumatic system monitoring
- material handling
- vacuum and positive pressure ranges available



Connectivity Weld Slag Protection Solutions

Depending on the application, users can choose from many different levels of protection. Plug body, coupling nuts, cable jacket, and protective sleeving are all components of the cordset that can be altered to provide weld slag protection.



Plug Body & Coupling Nuts

TPE (Thermo-Plastic Elastomer) and PTFE Coating

- TPE used as mold material in cordset plug body
- Coupling nuts coated with PTFE
- Provide excellent resistance to weld-slag buildup



Cable Jacket

See page 93

CPE (Chlorinated Polyethylene) Jacket Over EPDM Rubber

CPE
Resistance Welding

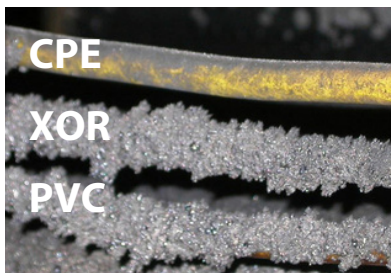

Turck CPE cable still performing after 24,000 welds.

- Excellent resistance to flame and temperature extremes
- Superior resistance to tears, cuts and abrasions
- Lifetime rating of over 2 million cycles

The cable jacket most commonly used in weld environments is CPE rubber.

TPE (Thermo-Plastic Elastomer)

TPE
Resistance Welding



Turck TPE cable still performing after 6,000 welds.

- Excellent resistance to weld slag buildup
- Available in more configurations
- Allows for easier cable stripping
- Lifetime rating of over 2 million cycles

If CPE rubber is too rugged for your application, we also offer TPE jacket material, sometimes called TPR (Thermo-Plastic Rubber).

Aramid Jacket

New Product!





Superior protection with no installation time.



- Covers entire cable jacket, captured under the molded plug body
- Excellent resistance to sparks, slag, and flexing.
- Capable of tolerating short-term temp spikes of up to 200 °C

The intricate weave of the over-braid eliminates any potential gaps in protection, reduces catch points with moving parts, and is capable of a smaller bend radius, resulting in a less bulky solution that saves space in the welding cell.

Connectivity Weld Slag Protection Solutions

Accessories See page 105

Viton Coated Fiberglass Sleaving	Expandable Silicone Sleaving
 <ul style="list-style-type: none"> ■ Slides over the quick disconnect area ■ Prevents accumulation of weld slag, dust and grease 	 <ul style="list-style-type: none"> ■ Provides a 'heat shrink' like fit ■ Protects cable, mold and coupling nut

Wrap Around Weld Shield Sleaving	Silicone Tubing	Clear Weld Seal Tape
 <ul style="list-style-type: none"> ■ Provides excellent resistance in welding environment ■ Used in wide operating temperature range ■ Rugged fiberglass material with hook and loop closure 	 <ul style="list-style-type: none"> ■ Made of translucent rubber ■ Assembled on cordsets end to end, up to four meters 	 <ul style="list-style-type: none"> ■ Protects open areas between silicone tubing and mold body

Combine Multiple Solutions for Ultimate Protection





Welding Tips

- Use PTFE coated threads and Weldguard front faces to protect sensor surfaces wherever extreme accumulation of weld slag is common.

- Specialty tubing can be used to further protect a sensor and cordset from weld slag accumulation. Tubing that is resistant to both the accumulation of weld slag and high heat may be placed over the cordset and connector, fitting against the barrel end.

Weld Slag Cleaning/Removal

- Clean weld slag accumulation from PTFE coatings or covers using a gloved hand, if possible. Avoid cleaning PTFE with a tool or steel brush, as this can lead to slag accumulation quickly re-attaching to the areas worn by the tool or steel brush.

- Avoid cleaning surfaces coated with Turck's Weldguard material. The Weldguard material sheds weld slag, and should not require regular cleaning.

- Stainless steel faced sensors will stand up to much more frequent and abusive wire brushing or other cleaning. However, if the sensors are coated in PTFE or Weldguard, the coatings will suffer damage.

Sensor Contact

- If contact with the sensor is a "glancing" blow across the entire sensing face and/or threads or side, use the extremely durable Armorguard tool steel protective products.
- If contact occurs directly on the sensing face, use a stainless steel sensor.

40 mm Cubed Sensors

- Always remember a cubed sensor's face orientation before removal.
- When working with popular CA40 sensors with the metal BS 2.1 or BS 2.0 brackets, use a 5/32 allen wrench socket instead(2.5 mm). This allows for quicker and easier removal and reinstallation.

Cordsets

- Avoid cross threading and the occasional difficulty attaching cordsets to sensors by turning the cordset's coupling nut in reverse (counter-clockwise) for about a turn (adjust to personal preference), watching to hold it as straight as possible before turning in the clockwise direction to tighten.
- If LED visibility is a problem, use an extension cordset with LEDs molded on the connector.

Content

Weldguard®	11
BIM-UNR, BIM-UNT Q4.7, Q5.5,	12
Q08 Rectangular Style CA40,	14-16
CK40, Rectangular Style 8 mm	18
Barrel 12 mm Barrel 18 mm Barrel	20-28
30 mm Barrel	30-36
	38-44
	46-48
Armorguard®	51
CA40, Rectangular Style	52
8 mm Barrel, 12 mm Barrel	54
18 mm Barrel, 30 mm Barrel	56
Stainless Steel Front Face	59
8 mm Barrel, Q08 Rectangular Style	60, 64
12 mm Barrel	60, 66
18 mm Barrel, 30 mm Barrel	62, 68
Stoneface®	71
12 mm Barrel	72, 78
18 mm Barrel	74, 78
30 mm Barrel	76, 78
Nut Detection Sensors	81
5 - 20 mm Nuts	82
Instrumentation	85
Flow Sensors	86
Pressure Sensors	88-90
Connectivity	93
M8 Picofast® Cordsets	97
M12 Eurofast® Cordsets	98-102
1/2" Microfast® Cordsets	103
7/8" Minifast® Cordstes	104
Accessories	105-107
Accessories	109
Index	122



weld **guard**[®]

Weldguard sensors use a proprietary material on the sensing face that is:

- Independently tested to over 25,000 operations without failure
- Impervious to weld spatter that creates pitting, chipping and cracking caused by resistance welding
- A superior replacement for any type of material used on a sensing face
- Able to withstand high heat
- Resistance to pitting, chipping and cracking caused by molten metal traveling at high velocity





■ Protects against:





Resistance Welding

We reserve the right to make technical alterations without prior notice.

Weldguard

	BIM-UNR	BIM-UNT	Q4.7	Q5.5	Q08
					
Housing	UNR	UNT	4.7 mm	5.5 mm	8 mm
Sensing Range	Magnetic	Magnetic	2	2	5 - 8
Pages	12	12	14	14	16

	Rectangular	Embeddable/Nonembeddable Metal Barrel			
					
Housing	30 mm	8 mm	12 mm	18 mm	30 mm
Sensing Range	20 - 50 mm	1.5 - 6 mm	2 - 10 mm	5 - 14 mm	10 - 30 mm
Pages	18	20-28	30-36	38-44	46-48

Weldguard | UNR, UNT

T-groove, C-groove, Tie-rod, and Round Cylinder Style

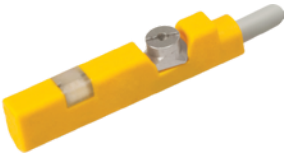
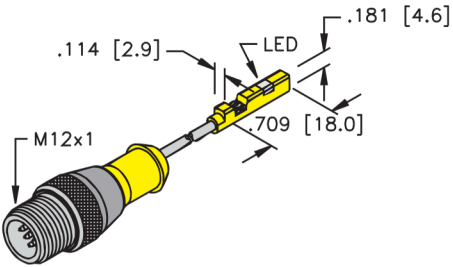
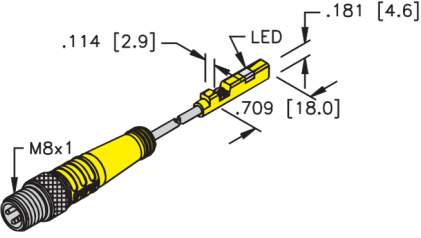
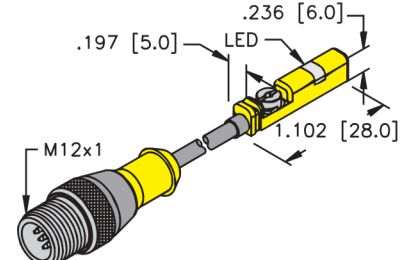
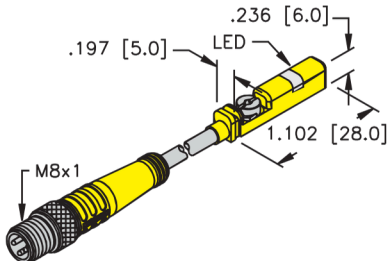
Housing Style	Dimension Drawings
	<p>A</p>  <p>UNR - Eurofast Quick Disconnect</p>
<p>B</p>  <p>UNR - Picofast Quick Disconnect</p>	<p>C</p>  <p>UNT - Eurofast Quick Disconnect</p>
<p>D</p>  <p>UNT - Picofast Quick Disconnect</p>	

We reserve the right to make technical alterations without prior notice.

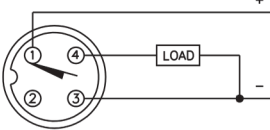
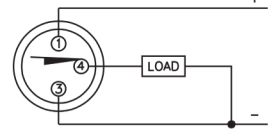
Wiring Diagrams/Mating Cordsets	
<p>1</p>  <p>Mating Cordset: RK 4T-*</p>	<p>2</p>  <p>Mating Cordset: PKG 3M-*</p>

A1 3-wire DC - Magnetic (AN, RN, AP, RP)	
<p>Ripple: $\leq 10\%$</p> <p>Differential Travel (Hysteresis): ≤ 1 mm</p> <p>Voltage Drop Across Conducting Sensor: ≤ 1.8 V</p> <p>Trigger Current for Short Circuit Protection: ≥ 220 mA on 200 mA Load Current ≥ 170 mA on 150 mA Load Current ≥ 120 mA on 100 mA Load Current</p> <p>Off-State (Leakage) Current: ≤ 0.1 mA</p> <p>No-Load Current: ≤ 15 mA;</p> <p>Pass Speed: ≤ 10 ms; ≤ 3 ms (UNR)</p>	<p>Power-On Effect: Per IEC 947-5-2 Incorporated</p> <p>Reverse Polarity Protection: Incorporated Per EN 60947-5-2 ≤ 0.1 mm, ≤ 0.3 mm (UNR) 30 g, 11 ms 55 Hz, 1 mm Amplitude in all 3 Planes $\geq \pm$</p> <p>Transient Protection: 0.1 mm, ≥ 0.3 mm (UNR)</p> <p>Shock:</p> <p>Vibration:</p> <p>Repeatability:</p>

Additional Specifications
Magnetic Actuation Strength (Gauss): 20-350

Weldguard | UNR, UNT

T-groove, C-groove, Tie-rod, and Round Cylinder Style

Part Number/ ID Number	Output	Voltage	Switching Freq. (Hz)	Operating Current (mA)	Operating Temp. (°C)	Protection	Housing	Power LED	Output LED	Cable Length/Jacket	Wiring Diagrams Dimension Drawings	Spec List
BIM-UNR-AP6X-0.3-RS4T/S1764 W/M 46858416	3-wire DC PNP	10-30 VDC	300	≤100	-25 to +70	IP67	PP	N/A	YE	0.3M/TPU	A 1	A1
BIM-UNR-AP6X-0.3-PSG3M/S1764 W/M 4685889	3-wire DC PNP	10-30 VDC	300	≤100	-25 to +70	IP67	PP	N/A	YE	0.3M/TPU	B 2	A1
BIM-UNR-AP6X-0.3-RS4T/S1154 46858419	3-wire DC PNP	10-30 VDC	300	≤100	-25 to +70	IP67	PP	N/A	YE	0.3M/TPU	A 1	A1
BIM-UNR-AP6X-0.3-PSG3M/S1154 46858414	3-wire DC PNP	10-30 VDC	300	≤100	-25 to +70	IP67	PP	N/A	YE	0.3M/TPU	B 2	A1
BIM-UNT-AP6X-0.2-RS4T/S1764 4685798	3-wire DC PNP	10-30 VDC	1000	≤200	-25 to +70	IP67	PA 12	N/A	YE	0.2M/TPU	C 1	A1
BIM-UNT-AP6X-0.3-PSG3M/S1764 4688097	3-wire DC PNP	10-30 VDC	1000	≤200	-25 to +70	IP67	PA 12	N/A	YE	0.3M/TPU	D 2	A1
BIM-UNT-AP6X-0.5-PSG3M/S1764 4685794	3-wire DC PNP	10-30 VDC	1000	≤200	-25 to +70	IP67	PA 12	N/A	YE	0.5M/TPU	D 2	A1
BIM-UNT-AP6X-0.3-PSG3M/S1765 4685799	3-wire DC PNP	10-30 VDC	1000	≤200	-25 to +70	IP67	PA 12	N/A	YE	0.3M/TPU	D 2	A1
BIM-UNT-AP6X-0.3-PSG3M/S1154 46857219	3-wire DC PNP	10-30 VDC	1000	≤200	-25 to +70	IP67	PA 12	N/A	YE	0.3M/TPU	D 2	A1
BIM-UNT-AP6X-0.5-RS4T/S1154 46857268	3-wire DC PNP	10-30 VDC	1000	≤200	-25 to +70	IP67	PA 12	N/A	YE	0.5M/TPU	C 1	A1

Weldguard

We reserve the right to make technical alterations without prior notice.

"/S1764" = Weldguard coated sensor with viton/fiberglass sleeving. Sleeve starts on sensor end, and covers all but 100 mm of cable held in place by shrink tube.
 "/S1154" = Weldguard coated sensor with PTFE sleeving covering the entire cable length and captured under the connector mold body.
 "/S1589" = Weldguard coating added to sensor.

Weldguard | Q4.7, Q5.5

Top Sensing Subminiature Qpak Housing

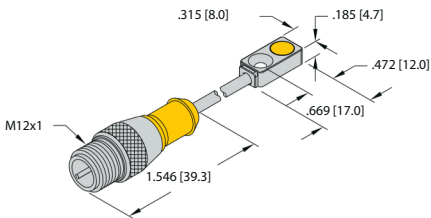
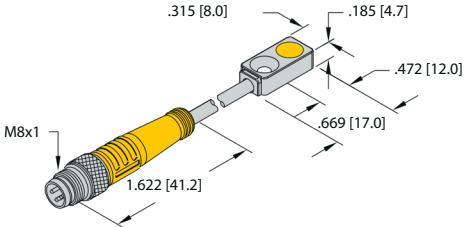
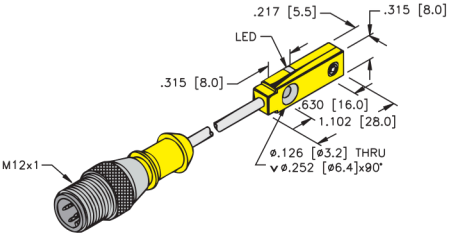
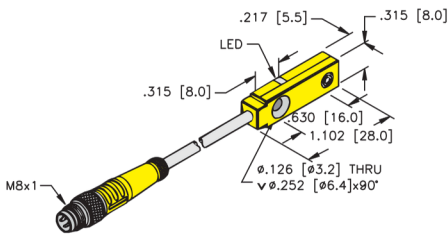
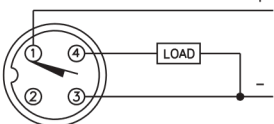
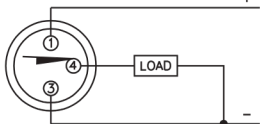
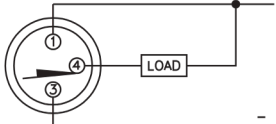
Housing Style	Dimension Drawings	
	<p>A</p>  <p>4.7 mm - M12 Eurofast Quick Disconnect</p>	
<p>B</p>  <p>4.7 mm - M8 Picofast Quick Disconnect</p>	<p>C</p>  <p>5.5 mm - M12 Eurofast Quick Disconnect</p>	
<p>D</p>  <p>5.5 mm - M8 Picofast Quick Disconnect</p>		
Wiring Diagrams/Mating Cordsets		
<p>1</p>  <p>Mating Cordset: RK 4T-*</p>	<p>2</p>  <p>Mating Cordset: PKG 3M-*</p>	<p>3</p>  <p>Mating Cordset: PKG 3M-*</p>
A2 3 and 4-wire DC - (AN, RN, AP, RP, VN, VP)		
<p>Ripple: ≤10%</p> <p>Differential Travel (Hysteresis): 3-15% (5% typical)</p> <p>Voltage Drop Across Conducting Sensor: ≤1.8 V</p> <p>Trigger Current for Short Circuit Protection: ≥220 mA on 200 mA Load Current ≥170 mA on 150 mA Load Current ≥120 mA on 100 mA Load Current</p> <p>Off-State (Leakage) Current: ≤0.1 mA</p> <p>No-Load Current: ≤15 mA (Ferrite, Uprox, Rectangular) ≤20 mA (Uprox+, Uprox 3)</p> <p>Time Delay Before Availability: ≤8 ms</p>	<p>Power-On Effect: Per IEC 947-5-2 Incorporated</p> <p>Reverse Polarity Protection: Incorporated Per EN 60947-5-2</p> <p>Wire-Break Protection: ±10% 30 g, 11 ms 55 Hz, 1 mm</p> <p>Transient Protection: Amplitude in all 3 Planes ≤2% of Rated Operating Distance</p> <p>Temperature Drift: Rated Operating Distance</p> <p>Shock:</p> <p>Vibration:</p> <p>Repeatability:</p>	

We reserve the right to make technical alterations without prior notice.

Weldguard | Q4.7, Q5.5

Top Sensing Subminiature Qpak Housing

Part Number/ ID Number	Features	Sensing Range (mm)	Output	Voltage	Switching Freq. (Hz)	Operating Current (mA)	Operating Temp. (°C)	Protection	Housing	Front Cap/Face	Power LED	Output LED	Cable Length/Jacket	Wiring Diagrams Dimension Drawings	Spec List	
BI2-Q4.7-AP6X-0.3-RS4T/S1154 16140067		2	3-wire DC PNP	10-30 VDC	1000	≤100	0 to +85	IP67	Zinc	WG	N/A	YE	0.3M/TPU	A	1	A2
BI2-Q4.7-AP6X-0.5-RS4T/S1154 16140069		2	3-wire DC PNP	10-30 VDC	1000	≤100	0 to +85	IP67	Zinc	WG	N/A	YE	0.5M/TPU	A	1	A2
BI2-Q4.7-AP6X-0.2-PSG3M/S1154 1614097		2	3-wire DC PNP	10-30 VDC	1000	≤100	0 to +85	IP67	Zinc	WG	N/A	YE	0.2M/TPU	B	2	A2
BI2-Q4.7-AP6X-0.5-PSG3M/S1154 16140025		2	3-wire DC PNP	10-30 VDC	1000	≤100	0 to +85	IP67	Zinc	WG	N/A	YE	0.5M/TPU	B	2	A2
BI2-Q4.7-AP6X-0.3-RS4T/S1589 16140023		2	3-wire DC PNP	10-30 VDC	1000	≤100	0 to +85	IP67	Zinc	WG	N/A	YE	0.3M/TPU	A	1	A2
BI2-Q4.7-AP6X-0.3-PSG3M/S1589 16140001		2	3-wire DC PNP	10-30 VDC	1000	≤100	0 to +85	IP67	Zinc	WG	N/A	YE	0.3M/TPU	B	2	A2
BI2-Q5.5-AN6X-0.5-PSG3M/S1764 16131005		2	3-wire DC NPN	10-30 VDC	2000	≤150	-25 to +85	IP67	PP-GF20	WG	N/A	YE	0.5M/TPU	D	3	A2
BI2-Q5.5-AP6X-0.5-RS4T/S1764 16130001		2	3-wire DC PNP	10-30 VDC	2000	≤150	-25 to +85	IP67	PP-GF20	WG	N/A	YE	0.5M/TPU	C	1	A2
BI2-Q5.5-AP6X-0.4-RS4T/S34/S1764 1613063	WFI	2	3-wire DC PNP	10-30 VDC	2000	≤150	-25 to +85	IP67	PP-GF20	WG	N/A	YE	0.4M/TPU	C	1	A2
BI2-Q5.5-AP6X-0.2-RS4T/S34/S1764 16130011	WFI	2	3-wire DC PNP	10-30 VDC	2000	≤150	-25 to +85	IP67	PP-GF20	WG	N/A	YE	0.2M/TPU	C	1	A2
BI2-Q5.5-AP6X-0.2-PSG3M/S1154 16130019		2	3-wire DC PNP	10-30 VDC	2000	≤150	-25 to +85	IP67	PP-GF20	WG	N/A	YE	0.2M/TPU	D	2	A2

Weldguard

We reserve the right to make technical alterations without prior notice.

"/S1764" = Weldguard coated sensor with viton/fiberglass sleeving. Sleeve starts on sensor end, and covers all but 100 mm of cable held in place by shrink tube.

"/S1154" = Weldguard coated sensor with PTFE sleeving covering the entire cable length and captured under the connector mold body.

"/S1589" = Weldguard coating added to sensor.

Weldguard | Q08

Top Sensing Subminiature Qpak Housing

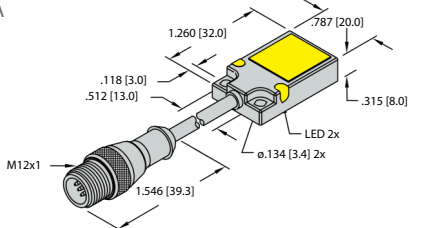
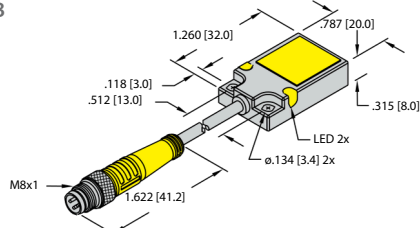
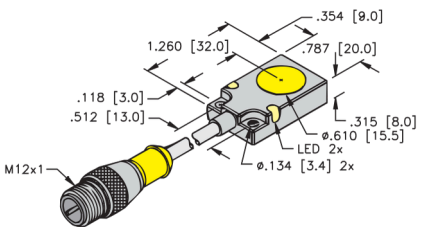
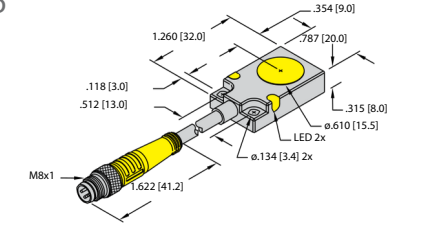
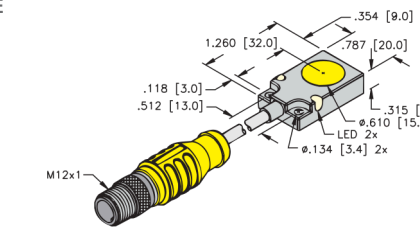
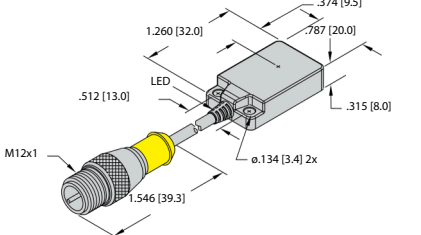
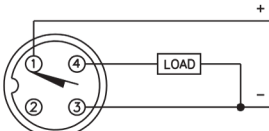
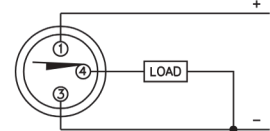
Housing Style	Dimension Drawings	
	<p>A</p>  <p>8.0 mm - M12 Eurofast Quick Disconnect</p>	<p>B</p>  <p>8.0 mm - M8 Picofast Quick Disconnect</p>
<p>C</p>  <p>8.0 mm - M12 Eurofast Quick Disconnect</p>	<p>D</p>  <p>8.0 mm - M8 Picofast Quick Disconnect</p>	<p>E</p>  <p>8.0 mm - M12 Eurofast Quick Disconnect W/ LED</p>
<p>F</p>  <p>8.0 mm - M12 Eurofast Quick Disconnect</p>		
Wiring Diagrams/Mating Cordsets		
<p>1</p>  <p>Mating Cordset: RK 4T-*, RKV 4T-*</p>	<p>2</p>  <p>Mating Cordset: PKG 3M-*</p>	
A2 3 and 4-wire DC - (AN, RN, AP, RP, VN, VP)		
<p>Ripple: $\leq 10\%$</p> <p>Differential Travel (Hysteresis): 3-15% (5% typical)</p> <p>Voltage Drop Across Conducting Sensor: $\leq 1.8\text{ V}$</p> <p>Trigger Current for Short Circuit Protection:</p> <ul style="list-style-type: none"> $\geq 220\text{ mA}$ on 200 mA Load Current $\geq 170\text{ mA}$ on 150 mA Load Current $\geq 120\text{ mA}$ on 100 mA Load Current <p>Off-State (Leakage) Current:</p> <ul style="list-style-type: none"> $\leq 0.1\text{ mA}$ $\leq 15\text{ mA}$ (Ferrite, Uprox, Rectangular) $\leq 20\text{ mA}$ (Uprox+, Uprox 3) <p>Time Delay Before Availability: $\leq 8\text{ ms}$</p>	<p>Power-On Effect: Per IEC 947-5-2 Incorporated</p> <p>Reverse Polarity Protection: Incorporated Per EN 60947-5-2</p> <p>Wire-Break Protection: $\leq \pm 10\%$ 30 g, 11 ms 55 Hz, 1 mm</p> <p>Transient Protection: Amplitude in all 3 Planes $\leq 2\%$ of Rated Operating Distance</p> <p>Temperature Drift:</p> <ul style="list-style-type: none"> Shock: Vibration: Repeatability: 	

We reserve the right to make technical alterations without prior notice.

Weldguard | Q08

Top Sensing Subminiature Qpak Housing

Part Number/ ID Number	Features	Sensing Range (mm)	Output	Voltage	Switching Freq. (Hz)	Operating Current (mA)	Operating Temp. (°C)	Protection	Housing	Front Cap/Face	Power LED	Output LED	Cable Length/Jacket	Wiring Diagrams Dimension Drawings	Spec List	
BI8U-Q08-AP6X2-1-RS4T/S1764 1662089	Uprox+	8	3-wire DC PNP	10-30 VDC	1000	≤200	-30 to +85	IP68	Zinc	WG	GN	YE	1M/TPU	A	1	A2
BI8U-Q08-AP6X2-0.5-RS4T/S1764 16620066	Uprox+	8	3-wire DC PNP	10-30 VDC	1000	≤200	-30 to +85	IP68	Zinc	WG	GN	YE	0.5M/TPU	A	1	A2
BI8U-Q08-AP6X2-0.5-PSG3M/S1764 16620060	Uprox+	8	3-wire DC PNP	10-30 VDC	1000	≤200	-30 to +85	IP68	Zinc	WG	GN	YE	0.5M/TPU	B	2	A2
BI8U-Q08-AP6X2-0.5-RS4T/S1765 1662087	Uprox+	8	3-wire DC PNP	10-30 VDC	1000	≤200	-30 to +85	IP68	Zinc	WG	GN	YE	0.5M/TPU	A	1	A2
BI8U-Q08-AP6X2-0.2-RS4T/S1589 1662083	Uprox+	8	3-wire DC PNP	10-30 VDC	1000	≤200	-30 to +85	IP68	Zinc	WG	GN	YE	0.2M/TPU	A	1	A2
BI7-Q08-AP6X2-0.5-RS4T/S1764 1601676		7	3-wire DC PNP	10-30 VDC	500	≤200	-25 to +70	IP67	Zinc	WG	GN	YE	0.5M/TPU	C	1	A2
BI7-Q08-AP6X2-0.5-RS4T/S1765 16016002		7	3-wire DC PNP	10-30 VDC	500	≤200	-25 to +70	IP67	Zinc	WG	GN	YE	0.5M/TPU	C	1	A2
BI7-Q08-AP6X2-0.5-PSG3M/S1765 1601678		7	3-wire DC PNP	10-30 VDC	500	≤200	-25 to +70	IP67	Zinc	WG	GN	YE	0.5M/TPU	D	2	A2
BI7-Q08-AP6X2-0.5-RS4T/S1154 16016004		7	3-wire DC PNP	10-30 VDC	500	≤200	-25 to +70	IP67	Zinc	WG	GN	YE	0.5M/TPU	C	1	A2
BI7-Q08-AP6X2-0.3-RS4T/S1154 16016006		7	3-wire DC PNP	10-30 VDC	500	≤200	-25 to +70	IP67	Zinc	WG	GN	YE	0.3M/TPU	C	1	A2
BI7-Q08-AP6X2-0.2-PSG3M/S1154 16016005		7	3-wire DC PNP	10-30 VDC	500	≤200	-25 to +70	IP67	Zinc	WG	GN	YE	0.2M/TPU	D	2	A2
BI7-Q08-AP6X2-0.3-RSE 4T-P7X2/S1589 1601671		7	3-wire DC PNP	10-30 VDC	500	≤200	-25 to +70	IP67	Zinc	WG	GN	YE	0.3M/TPU	E	1	A2
BI7-Q08-AP6X2-0.2-RS4T/S1589 16016001		7	3-wire DC PNP	10-30 VDC	500	≤200	-25 to +70	IP 67	Zinc	WG	GN	YE	0.2M/TPU	C	1	A2
BI7-Q08F-AP6X-0.2-RS4T/S1154 16089164	SSF	7	3-wire DC PNP	10-30 VDC	200	≤200	-25 to +70	IP68/69K	SS	WG	N/A	YE	0.2M/TPU	F	1	A2
BI7-Q08F-AP6X-0.2-RS4T/S1589 16089163	SSF	7	3-wire DC PNP	10-30 VDC	200	≤200	-25 to +70	IP68/69K	SS	WG	N/A	YE	0.2M/TPU	F	1	A2
BI5U-Q08-AP6X2-0.3-RS4T/S1154 1608899	Uprox	5	3-wire DC PNP	10-30 VDC	250	≤200	-30 to +85	IP67	Zinc	WG	GN	YE	0.3M/TPU	C	1	A2
BI5U-Q08-AP6X2-0.2-RS4T/S1589 1608975	Uprox	5	3-wire DC PNP	10-30 VDC	250	≤200	-30 to +85	IP67	Zinc	WG	GN	YE	0.2M/TPU	C	1	A2

We reserve the right to make technical alterations without prior notice.

Weldguard

"S1764" = Weldguard coated sensor with viton/fiberglass sleeving. Sleeve starts on sensor end, and covers all but 100 mm of cable held in place by shrink tube.

"S1765" = Weldguard coated sensor with 1/4" diameter Silicone. Length of tubing is 200 mm less than total cable length.

"S1154" = Weldguard coated sensor with PTFE sleeving covering the entire cable length and captured under the connector mold body.

"S1589" = Weldguard coating added to sensor.

Weldguard | CA40, CK40

Rotatable Sensing Head with 2 and 3-Wire Outputs

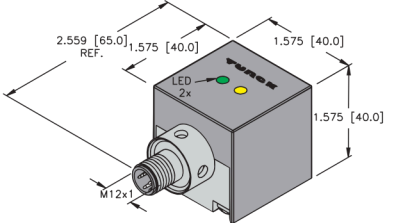
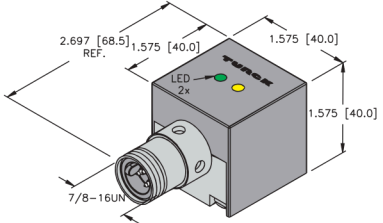
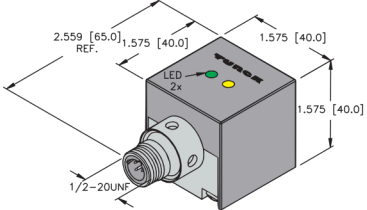
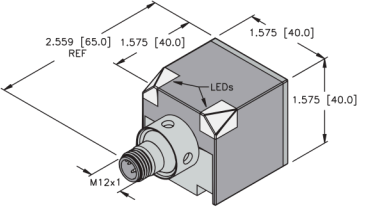
Housing Style	Dimension Drawings	
	<p>A</p>  <p>CA40 - Embeddable, Eurofast Connector</p>	<p>B</p>  <p>CA40 - Embeddable, Minifast Connector</p>
<p>C</p>  <p>CA40 - Embeddable, Microfast Connector</p>	<p>D</p>  <p>CK40 - Embeddable/Nonembeddable, Eurofast Connector</p>	

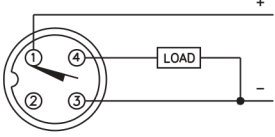
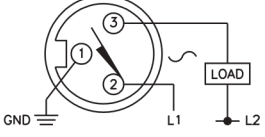
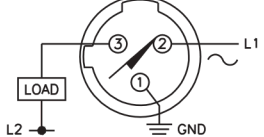
Wiring Diagrams/Mating Cordsets		
<p>1</p>  <p>Mating Cordset: RK 4T-*</p>	<p>2</p>  <p>Mating Cordset: RKM 30-*M</p>	<p>3</p>  <p>Mating Cordset: KB 3T-*</p>

A2	3 and 4-wire DC - (AN, RN, AP, RP, VN, VP)	
<p>Ripple: $\leq 10\%$</p> <p>Differential Travel (Hysteresis): 3-15% (5% typical)</p> <p>Voltage Drop Across Conducting Sensor: $\leq 1.8\text{ V}$</p> <p>Trigger Current for Short Circuit Protection: $\geq 220\text{ mA}$ on 200 mA Load Current $\geq 170\text{ mA}$ on 150 mA Load Current $\geq 120\text{ mA}$ on 100 mA Load Current</p> <p>Off-State (Leakage) Current: $\leq 0.1\text{ mA}$</p> <p>No-Load Current: $\leq 15\text{ mA}$ (Ferrite, Uprox, Rectangular) $\leq 20\text{ mA}$ (Uprox+, Uprox 3)</p> <p>Time Delay Before Availability: $\leq 8\text{ ms}$</p>	<p>Power-On Effect: Per IEC 947-5-2 Incorporated</p> <p>Reverse Polarity Protection: Incorporated Per EN 60947-5-2</p> <p>Wire-Break Protection: $\leq \pm 10\%$ 30 g, 11 ms 55 Hz, 1 mm</p> <p>Transient Protection: Amplitude in all 3 Planes $\leq 2\%$ of Rated Operating Distance</p> <p>Temperature Drift: Rated Operating Distance</p> <p>Shock:</p> <p>Vibration:</p> <p>Repeatability:</p>	
A4	2-wire AC/DC w/ Short-Circuit Protection - (ADZ, RDZ, FDZ, VDZ)	
<p>Line Frequency: $\geq 50\text{...} \leq 60\text{ Hz}$ 3-15% (5% typical) $\leq 6.0\text{ V AC}$: $\geq 440\text{ mA}$; DC: $\geq 330\text{ mA AC}$: $\geq 120\text{ mA}$; DC: $\geq 120\text{ mA AC}$: $\leq 400\text{ mA}$; DC: $\leq 300\text{ mA AC}$: $\leq 100\text{ mA}$; DC: $\leq 100\text{ mA}$ $\leq 1.7\text{ mA (AC)}$ $\leq 1.5\text{ mA (DC)}$</p> <p>Continuous Load Current:</p> <p>Off-State (leakage) Current:</p>	<p>Minimum Load Current: $\geq 3.0\text{ mA}$</p> <p>Inrush Current: $\leq 3\text{ A}$ ($\leq 20\text{ ms}$, max 5 Hz)</p> <p>Power-On Effect: Per IEC 947-5-2</p> <p>Transient Protection: Per EN 60947-5-2</p> <p>Shock: 30 g, 11 ms</p> <p>Vibration: 55 Hz, 1 mm Amplitude, in all 3 Planes</p> <p>Repeatability: $\leq 2\%$ of Rated Operating Distance</p>	

We reserve the right to make technical alterations without prior notice.

Weldguard | CA40, CK40

Rotatable Sensing Head with 2 and 3-Wire Outputs

Part Number/ ID Number	Features	Sensing Range (mm)	Output	Voltage	Switching Freq. (Hz)	Operating Current (mA)	Operating Temp. (°C)	Protection	Housing	Front Cap/Face	Power LED	Wire Output	Dimension Drawings	Spec List
BI20U-CA40-AP6X2-H1141/S1590W/BS2.1 1627295	Uprox	20	3-wire DC PNP	10-30 VDC	250	≤200	0 to +70	IP67	AL	WG	GN	YE	A 1	A2
BI20U-CA40-AP6X2-H1141/S1590 W/BS2.0 1627297	Uprox	20	3-wire DC PNP	10-30 VDC	250	≤200	0 to +70	IP67	AL	WG	GN	YE	A 1	A2
BI20U-CA40-ADZ30X2-B1131/S1590W/BS2.1 4283295	Uprox	20	2-wire AC/DC Short-Circuit Protected	20-250 VAC/10-300 VDC	20	≤400/300	-30 to +85	IP67	AL	WG	GN	YE	B 2	A4
BI20U-CA40-ADZ30X2-B3131/S34/S1590 4283594	WFI	20	2-wire AC/DC Short-Circuit Protected	20-250 VAC/10-300 VDC	20	≤400/300	-30 to +85	IP67	AL	WG	GN	YE	C 3	A4
BI30U-CK40-AP6X2-H1141/S1590 W/BS 4 1625893	Uprox+	30	3-wire DC PNP	10-30 VDC	250	≤200	-10 to +60	IP68	PBT	WG	GN	YE	D 1	A2
NI50U-CK40-AP6X2-H1141/S1590 W/BS 4 1625891	Uprox+	50	3-wire DC PNP	10-30 VDC	250	≤200	-30 to +85	IP68	PBT	WG	GN	YE	D 1	A2
NI35U-CK40-AP6X2-H1141/S1590 W/BS 4 1625892	Uprox	35	3-wire DC PNP	10-30 VDC	250	≤200	-30 to +85	IP68	PBT	WG	GN	YE	D 1	A2
NI25U-CK40-AP6X2-H1141/S1590 W/BS 2.1 1625796	Uprox	25	3-wire DC PNP	10-30 VDC	250	≤200	-30 to +85	IP68	PBT	WG	GN	YE	D 1	A2

"S1590" = Weldguard coating added to CA/CK 40 style sensor.

We reserve the right to make technical alterations without prior notice.

Weldguard

BS 2.1 Mounting Bracket

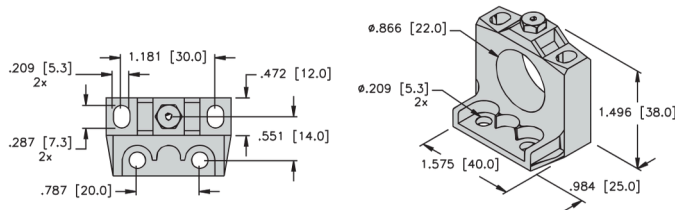

BS 2.0 Mounting Bracket

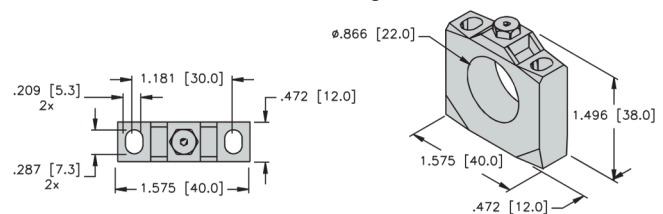

BS 4 Mounting Bracket

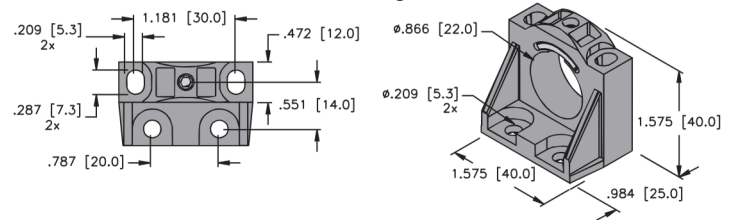

Weldguard | 8 mm

Embeddable Threaded Metal Barrels with Connector and DC Outputs

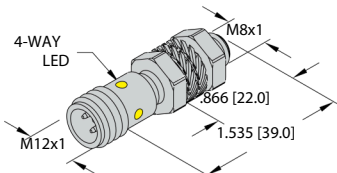
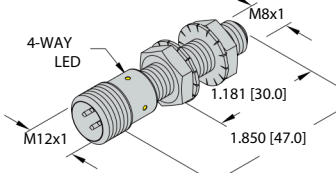
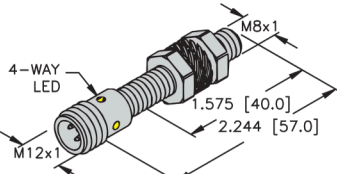
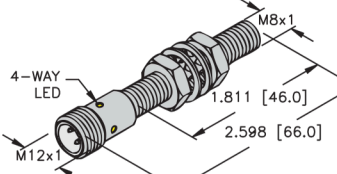
Housing Style	Dimension Drawings	
	<p>A</p>  <p>8 mm - Embeddable, Miniature Threaded, M12 Eurofast Connection</p>	<p>B</p>  <p>8 mm - Embeddable, Miniature Threaded, M12 Eurofast Connection</p>
<p>C</p>  <p>8 mm - Embeddable, Miniature Threaded, M12 Eurofast Connection</p>	<p>D</p>  <p>8 mm - Embeddable, Stainless Steel Barrel, M12 Eurofast Connection</p>	

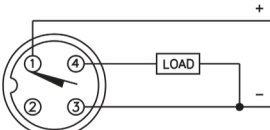
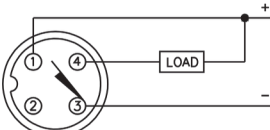
Wiring Diagrams/Mating Cordsets	
<p>1</p>  <p>Mating Cordset: RK 4T-*, RKV 4T-*</p>	<p>2</p>  <p>Mating Cordset: RK 4T-*</p>

A2	3 and 4-wire DC - (AN, RN, AP, RP, VN, VP)	
<p>Ripple: $\leq 10\%$</p> <p>Differential Travel (Hysteresis): 3-15% (5% typical)</p> <p>Voltage Drop Across Conducting Sensor: $\leq 1.8\text{ V}$</p> <p>Trigger Current for Short Circuit Protection: $\geq 220\text{ mA}$ on 200 mA Load Current $\geq 170\text{ mA}$ on 150 mA Load Current $\geq 120\text{ mA}$ on 100 mA Load Current</p> <p>Off-State (Leakage) Current: $\leq 0.1\text{ mA}$</p> <p>No-Load Current: $\leq 15\text{ mA}$ (Ferrite, Uprox, Rectangular) $\leq 20\text{ mA}$ (Uprox+, Uprox 3)</p> <p>Time Delay Before Availability: $\leq 8\text{ ms}$</p>	<p>Power-On Effect: Per IEC 947-5-2 Incorporated</p> <p>Reverse Polarity Protection: Incorporated Per EN 60947-5-2</p> <p>Wire-Break Protection: $\leq \pm 10\%$ 30 g, 11 ms 55 Hz, 1 mm</p> <p>Transient Protection: Amplitude in all 3 Planes $\leq 2\%$ of Rated Operating Distance</p> <p>Temperature Drift: Rated Operating Distance</p> <p>Shock:</p> <p>Vibration:</p> <p>Repeatability:</p>	
A7	3-wire DC Stainless Front Face Ext Range (AP, AN, RP, RN)	
<p>Ripple: $\leq 10\%$</p> <p>Differential Travel (Hysteresis): 20%</p> <p>Voltage Drop Across Conducting Sensor: $\leq 2\text{ V}$</p> <p>Trigger Current for Short Circuit Protection: $\geq 220\text{ mA}$ on 200 mA Load Current</p> <p>No-Load Current: $\leq 10\text{ mA}$</p> <p>Off-State (Leakage) Current: $\leq 0.1\text{ mA}$</p>	<p>Temperature Drift: $\leq \pm 10\%$ Incorporated Incorporated 30 g, 11 ms 55 Hz, 1 mm Amplitude, in all 3 Planes $\leq 5\%$ of Rated Operating Distance</p> <p>Shock: Distance</p> <p>Vibration:</p> <p>Repeatability:</p>	

We reserve the right to make technical alterations without prior notice.

Weldguard | 8 mm

Embeddable Threaded Metal Barrels with Connector and DC Outputs

Part Number/ ID Number	Features	Sensing Range (mm)	Output	Voltage	Switching Freq. (Hz)	Operating Current (mA)	Operating Temp. (°C)	Protection	Housing	Front Cap/Face	Power LED	Wiring Diagrams	Dimension Drawings	Spec List	
BI3U-EMT08-AP6X-H1341/S1589 46021560	Uprox3, PTFE	3	3-wire DC PNP	10-30 VDC	1000	≤150	0 to +60	IP68	TC	WG	N/A	YE	B	1	A2
BI3-EG08FE-AP6X-H1341/S1589 46147031	SSF	3	3-wire DC PNP	10-30 VDC	1000	≤200	-25 to +70	IP67	SS	WG	N/A	YE	D	1	A7
BI3-EGT08FE-AP6X-H1341/S1589 46147032	SSF, PTFE	3	3-wire DC PNP	10-30 VDC	1000	≤200	-25 to +70	IP67	TC	WG	N/A	YE	D	1	A7
BI2U-EGT08-AP6X-H1341/S1589 46020702	Uprox+, PTFE	2	3-wire DC PNP	10-30 VDC	2000	≤150	-30 to +85	IP68	TC	WG	N/A	YE	C	1	A2
BI2U-EG08-AP6X-H1341/S1589 46020340	Uprox+	2	3-wire DC PNP	10-30 VDC	2000	≤150	-30 to +85	IP68	SS	WG	N/A	YE	C	1	A2
BI2-EG08-AP6X-H1341/S1589 4602086		2	3-wire DC PNP	10-30 VDC	3000	≤150	-25 to +70	IP67	SS	WG	N/A	YE	C	1	A2
BI2-EG08-AN6X-H1341/S1589 4602182		2	3-wire DC NPN	10-30 VDC	3000	≤150	-25 to +70	IP67	SS	WG	N/A	YE	C	2	A2
BI2-EGT08-AP6X-H1341/S100/S1589 4602079	PTFE, High Temp. 100 °C	2	3-wire DC PNP	10-30 VDC	3000	≤150	-25 to +100	IP67	TC	WG	N/A	YE	C	1	A2
BI2-EG08K-AP6X-H1341/S1589 4669486	Short Barrel	2	3-wire DC PNP	10-30 VDC	3000	≤150	-25 to +70	IP67	SS	WG	N/A	YE	A	1	A2
BI2-EG08K-AN6X-H1341/S1589 4669580	Short Barrel	2	3-wire DC NPN	10-30 VDC	3000	≤150	-25 to +70	IP67	SS	WG	N/A	YE	A	2	A2
BI1.5U-EG08-AP6X-H1341/S1589 46005401	Uprox	1.5	3-wire DC PNP	10-30 VDC	2000	≤150	-30 to +85	IP68	SS	WG	N/A	YE	C	1	A2

"/S1589" = Weldguard coating added to sensor.

We reserve the right to make technical alterations without prior notice.

Weldguard

Weldguard | 8 mm

Embeddable Threaded Metal Barrels with Connector and DC Outputs

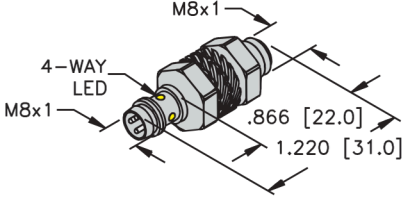
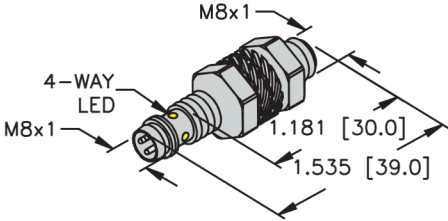
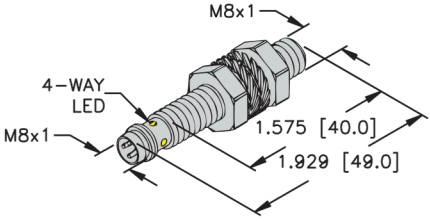
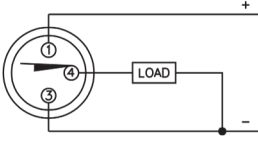
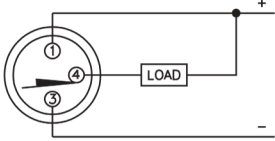
Housing Style	Dimension Drawings
	<p>A</p>  <p>8 mm - Embeddable, Miniature Threaded, M8 Picofast Quick Disconnect</p>
<p>B</p>  <p>8 mm - Embeddable, Miniature Threaded, M8 Picofast Quick Disconnect</p>	<p>C</p>  <p>8 mm - Embeddable, Miniature Threaded, M8 Picofast Quick Disconnect</p>
Wiring Diagrams/Mating Cordsets	
<p>1</p>  <p>Mating Cordset: PKG 3M-*</p>	<p>2</p>  <p>Mating Cordset: PKG 3M-*</p>
A2 3 and 4-wire DC - (AN, RN, AP, RP, VN, VP)	
<p>Ripple: $\leq 10\%$</p> <p>Differential Travel (Hysteresis): 3-15% (5% typical)</p> <p>Voltage Drop Across Conducting Sensor: $\leq 1.8\text{ V}$</p> <p>Trigger Current for Short Circuit Protection: $\geq 220\text{ mA}$ on 200 mA Load Current $\geq 170\text{ mA}$ on 150 mA Load Current $\geq 120\text{ mA}$ on 100 mA Load Current</p> <p>Off-State (Leakage) Current: $\leq 0.1\text{ mA}$</p> <p>No-Load Current: $\leq 15\text{ mA}$ (Ferrite, Uprox, Rectangular) $\leq 20\text{ mA}$ (Uprox+, Uprox 3)</p> <p>Time Delay Before Availability: $\leq 8\text{ ms}$</p>	<p>Power-On Effect: Per IEC 947-5-2 Incorporated</p> <p>Reverse Polarity Protection: Incorporated Per EN 60947-5-2</p> <p>Wire-Break Protection: $\leq \pm 10\%$ 30 g, 11 ms 55 Hz, 1 mm</p> <p>Transient Protection: Amplitude in all 3 Planes $\leq 2\%$ of Rated Operating Distance</p> <p>Temperature Drift: Rated Operating Distance</p> <p>Shock:</p> <p>Vibration:</p> <p>Repeatability:</p>

We reserve the right to make technical alterations without prior notice.

Weldguard | 8 mm

Embeddable Threaded Metal Barrels with Connector and DC Outputs

Part Number/ ID Number	Features	Sensing Range (mm)	Output	Voltage	Switching Freq. (Hz)	Operating Current (mA)	Operating Temp. (°C)	Protection	Housing	Front Cap/Face	Power LED	Wiring Diagrams			Dimension Drawings	Spec List
BI3U-EMT08-AP6X-V1131/S1589 46021550	Uprox3, PTFE	3	3-wire DC PNP	10-30 VDC	1000	≤150	0 to +60	IP68	TC	WG	N/A	YE	B	1	A2	
BI2U-EGT08-AP6X-V1131/S1589 46020701	Uprox+, PTFE	2	3-wire DC PNP	10-30 VDC	2000	≤150	-30 to +85	IP68	TC	WG	N/A	YE	C	1	A2	
BI2-EG08-AP6X-V1131/S1589 46020501		2	3-wire DC PNP	10-30 VDC	3000	≤150	-25 to +70	IP67	SS	WG	N/A	YE	C	1	A2	
BI2-EG08-AN6X-V1131/S1589 46021500		2	3-wire DC NPN	10-30 VDC	3000	≤150	-25 to +70	IP67	SS	WG	N/A	YE	C	2	A2	
BI2-EG08K-AP6X-V1131/S1589 46694003	Short Barrel	2	3-wire DC PNP	10-30 VDC	3000	≤150	-25 to +70	IP67	SS	WG	N/A	YE	A	1	A2	

"/S1589" = Weldguard coating added to sensor.

We reserve the right to make technical alterations without prior notice.

Weldguard

Weldguard | 8 mm

Embeddable Threaded Metal Barrels 3-Wire DC Outputs

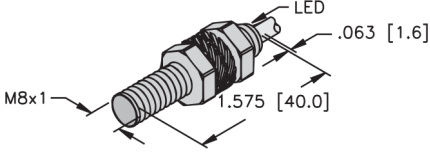
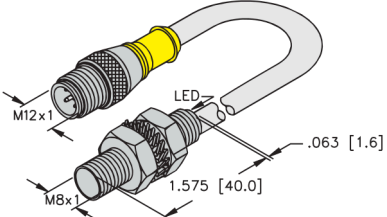
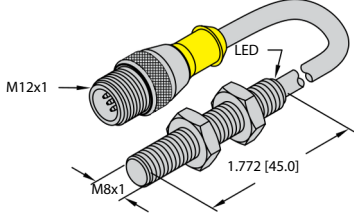
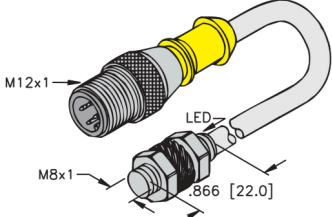
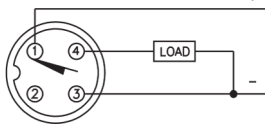
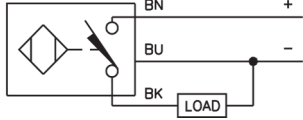
Housing Style	Dimension Drawings
	<p>A</p>  <p>8 mm - Embeddable, Miniature Threaded Barrel, Potted-In Cable</p>
<p>B</p>  <p>8 mm - Embeddable, Miniature Threaded, M12 Eurofast Quick Disconnect</p>	<p>C</p>  <p>8 mm - Embeddable, Stainless Steel Barrel, M12 Eurofast Quick Disconnect</p>
<p>D</p>  <p>8 mm - Embeddable, Stainless Steel Barrel, M12 Eurofast Connection</p>	
Wiring Diagrams/Mating Cordsets	
<p>1</p>  <p>Mating Cordset: RKV 4T-*; RK 4T-*</p>	<p>2</p> 
A2 3 and 4-wire DC - (AN, RN, AP, RP, VN, VP)	
<p>Ripple: $\leq 10\%$</p> <p>Differential Travel (Hysteresis): 3-15% (5% typical)</p> <p>Voltage Drop Across Conducting Sensor: $\leq 1.8\text{ V}$</p> <p>Trigger Current for Short Circuit Protection: $\geq 220\text{ mA}$ on 200 mA Load Current $\geq 170\text{ mA}$ on 150 mA Load Current $\geq 120\text{ mA}$ on 100 mA Load Current</p> <p>Off-State (Leakage) Current: $\leq 0.1\text{ mA}$</p> <p>No-Load Current: $\leq 15\text{ mA}$ (Ferrite, Uprox, Rectangular) $\leq 20\text{ mA}$ (Uprox+, Uprox 3)</p> <p>Time Delay Before Availability: $\leq 8\text{ ms}$</p>	<p>Power-On Effect: Per IEC 947-5-2 Incorporated</p> <p>Reverse Polarity Protection: Incorporated Per EN 60947-5-2</p> <p>Wire-Break Protection: $\leq \pm 10\%$ 30 g, 11 ms 55 Hz, 1 mm</p> <p>Transient Protection: Amplitude in all 3 Planes $\leq 2\%$ of Rated Operating Distance</p> <p>Temperature Drift: Rated Operating Distance</p> <p>Shock:</p> <p>Vibration:</p> <p>Repeatability:</p>
A7 3-wire DC Stainless Front Face Ext Range (AP, AN, RP, RN)	
<p>Ripple: $\leq 10\%$</p> <p>Differential Travel (Hysteresis): 20%</p> <p>Voltage Drop Across Conducting Sensor: $\leq 2\text{ V}$</p> <p>Trigger Current for Short Circuit Protection: $\geq 220\text{ mA}$ on 200 mA Load Current</p> <p>No-Load Current: $\leq 10\text{ mA}$</p> <p>Off-State (Leakage) Current: $\leq 0.1\text{ mA}$</p>	<p>Temperature Drift: $\leq \pm 10\%$ Incorporated Incorporated 30</p> <p>Reverse Polarity Protection: g, 11 ms 55 Hz, 1 mm Amplitude, in all</p> <p>Wire-Break Protection: 3 Planes $\leq 5\%$ of Rated Operating</p> <p>Shock: Distance</p> <p>Vibration:</p> <p>Repeatability:</p>

We reserve the right to make technical alterations without prior notice.

Weldguard | 8 mm

Embeddable Threaded Metal Barrels 3-Wire DC Outputs

Part Number/ ID Number	Features	Sensing Range (mm)	Output	Voltage	Switching Freq. (Hz)	Operating Current (mA)	Operating Temp. (°C)	Protection	Housing	Front Cap/Face	Power LED	Output LED	Cable Length/Jacket	Wiring Diagrams Dimension Drawings	Spec List
BI3-EGT08FE-AP6X-0.2-RS4T/S1154 46147013	SSF, PTFE	3	3-wire DC PNP	10-30 VDC	1000	≤200	-25 to +70	IP67	TC	WG	N/A	YE	0.2M/TPU	C 1	A7
BI2U-EG08-AP6X-0.2-RS4T/S1589 2690021	Uprox+	2	3-wire DC PNP	10-30 VDC	2000	≤150	-30 to +85	IP68	SS	WG	N/A	YE	0.2M/TPU	B 1	A2
BI2-EG08-AP6X/S1589 4602185		2	3-wire DC PNP	10-30 VDC	3000	≤150	-25 to +70	IP67	SS	WG	N/A	YE	2M/TPU	A 2	A2
BI2-EG08-AP6X-0.2-RS4T/S1589 4602084		2	3-wire DC PNP	10-30 VDC	3000	≤150	-25 to +70	IP67	SS	WG	N/A	YE	0.2M/TPU	B 1	A2
BI2-EG08K-AP6X-0.2-RS4T/S1589 46694951	Short Barrel	2	3-wire DC PNP	10-30 VDC	3000	≤150	-25 to +70	IP67	SS	WG	N/A	YE	0.2M/TPU	D 1	A2
BI2-EGT08K-AP6X-0.5-RS4T/S100/S1765 4602585	PTFE, High Temp. 100 °C	2	3-wire DC PNP	10-30 VDC	3000	≤150	-25 to +100	IP67	TC	WG	N/A	YE	0.5M/TPU	D 1	A2

"/S1765" = Weldguard coated sensor with 1/4" diameter silicone. Length of tubing is 200 mm less than total cable length.

"/S1154" = Weldguard coated sensor with PTFE sleeving covering the entire cable length and captured under the connector mold body.

"/S1589" = Weldguard coating added to sensor.

We reserve the right to make technical alterations without prior notice.

Weldguard

Weldguard | 8 mm

Embeddable Threaded Metal Barrels 2-Wire DC Outputs

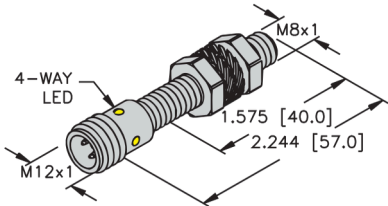
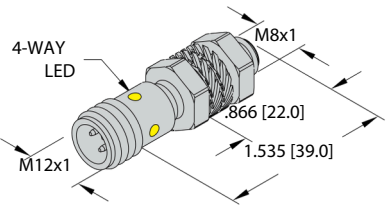
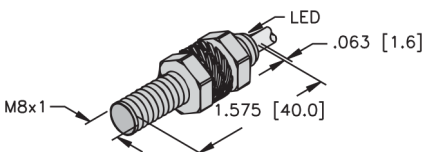
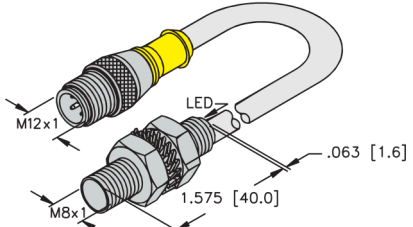
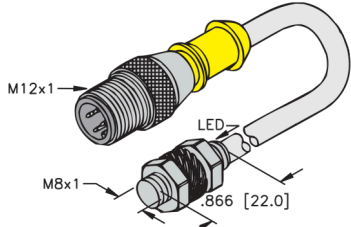
Housing Style	Dimension Drawings
	<p>A</p>  <p>8 mm - Embeddable, Miniature Threaded, M12 Eurofast Connection</p>
<p>B</p>  <p>8 mm - Embeddable, Miniature Threaded, M12 Eurofast Connection</p>	<p>C</p>  <p>8 mm - Embeddable, Miniature Threaded Barrel, Potted-In Cable</p>
<p>D</p>  <p>8 mm - Embeddable, Miniature Threaded, M12 Eurofast Quick Disconnect</p>	<p>E</p>  <p>8 mm - Embeddable, Miniature Threaded, M12 Eurofast Quick Disconnect</p>

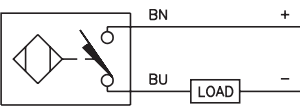
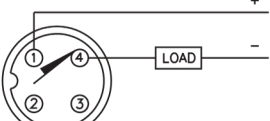
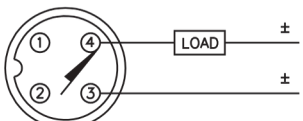
Wiring Diagrams/Mating Cordsets		
<p>1</p> 	<p>2</p>  <p>Mating Cordset: RK 4.23T-*</p>	<p>3</p>  <p>Mating Cordset: RK 4.2T-*</p>

A3 2-wire DC - (AD, RD, AG)	
<p>Ripple: $\leq 10\%$</p> <p>Differential Travel (Hysteresis): 3-15% (5% typical)</p> <p>Voltage Drop Across Conducting Sensor: Non-polarized (AD) $< 5.0\text{ V}$ Polarized (AG) $\leq 4.2\text{ V}$</p> <p>Trigger Current for Short Circuit Protection: $\geq 120\text{ mA}$</p> <p>Minimum Load Current: $\geq 3.0\text{ mA}$</p>	<p>Off-State (Leakage) Current: $\leq 0.8\text{ mA}$</p> <p>Power-On Effect: Per IEC 947-5-2</p> <p>Transient Protection: Per EN 60947-5-2</p> <p>Shock: 30 g, 11 ms</p> <p>Vibration: 55 Hz, 1 mm Amplitude in all 3 Planes</p> <p>Repeatability: $\leq 2\%$ of Rated Operating Distance</p>

We reserve the right to make technical alterations without prior notice.

Weldguard | 8 mm

Embeddable Threaded Metal Barrels 2-Wire DC Outputs

Part Number/ ID Number	Features	Sensing Range (mm)	Output	Voltage	Switching Freq. (Hz)	Operating Current (mA)	Operating Temp. (°C)	Protection	Housing	Front Cap/Face	Power LED	Output LED	Cable Length/Jacket	Wiring Diagrams Dimension Drawings	Spec List	
BI2-EG08-AG41X-H1341/S1589 4562095		2	2-wire DC	10-55 VDC	300	≤100	-25 to +70	IP67	SS	WG	N/A	YE	--	A	2	A3
BI2-EG08K-AG41X-H1341/S1589 4562090	Short Barrel	2	2-wire DC	10-55 VDC	300	≤100	-25 to +70	IP67	SS	WG	N/A	YE	--	B	2	A3
BI2-EGT08K-AG41X-H1341/S1589 4602599	PTFE, Short Barrel	2	2-wire DC	10-55 VDC	300	≤100	-25 to +70	IP67	TC	WG	N/A	YE	--	B	2	A3
BI2-EG08-AG41X/S1589 4562088		2	2-wire DC	10-55 VDC	300	≤100	-25 to +70	IP67	SS	WG	N/A	YE	2M/TPU	C	1	A3
BI2-EG08-AG41X-0.2-RS4.23T/S1589 4562097		2	2-wire DC	10-55 VDC	300	≤100	-25 to +70	IP67	SS	WG	N/A	YE	0.2M/TPU	D	2	A3
BI2-EGT08-AG41X-0.2-RS4.23T/S1589 4602593	PTFE	2	2-wire DC	10-55 VDC	300	≤100	-25 to +70	IP67	TC	WG	N/A	YE	0.2M/TPU	D	2	A3
BI2-EG08K-AG41X-0.3-RS4.23T/S1589 45620893	Short Barrel	2	2-wire DC	10-55 VDC	300	≤100	-25 to +70	IP67	SS	WG	N/A	YE	0.3M/TPU	E	2	A3
BI1.5-EG08-AD6X-H1341/S1589 4600298		1.5	2-wire DC	10-30 VDC	3000	≤100	-25 to +70	IP67	SS	WG	N/A	YE	--	A	3	A3

"S1589" = Weldguard coating added to sensor.

We reserve the right to make technical alterations without prior notice.

Weldguard

Weldguard | 8 mm

Nonembeddable Threaded Metal Barrels with Connector and DC Outputs

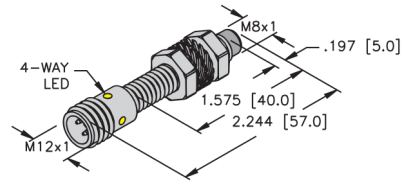
Housing Style	Dimension Drawings
	<p>A</p>  <p>8 mm - Nonembeddable, Miniature Threaded, M12 Eurofast Quick Disconnect</p>

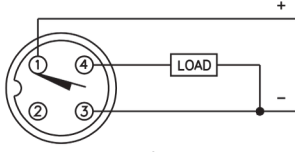
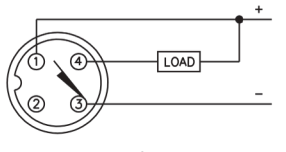
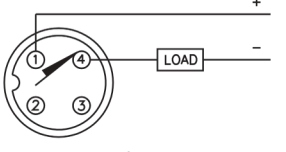
Wiring Diagrams/Mating Cordsets		
<p>1</p>  <p>Mating Cordset: RK 4T-*</p>	<p>2</p>  <p>Mating Cordset: RK 4T-*</p>	<p>3</p>  <p>Mating Cordset: RK 4.23T-*</p>

A2	3 and 4-wire DC - (AN, RN, AP, RP, VN, VP)	
<p>Ripple: $\leq 10\%$</p> <p>Differential Travel (Hysteresis): 3-15% (5% typical)</p> <p>Voltage Drop Across Conducting Sensor: $\leq 1.8\text{ V}$</p> <p>Trigger Current for Short Circuit Protection:</p> <ul style="list-style-type: none"> $\geq 220\text{ mA}$ on 200 mA Load Current $\geq 170\text{ mA}$ on 150 mA Load Current $\geq 120\text{ mA}$ on 100 mA Load Current <p>Off-State (Leakage) Current:</p> <ul style="list-style-type: none"> $\leq 0.1\text{ mA}$ No-Load Current: $\leq 15\text{ mA}$ (Ferrite, Uprox, Rectangular) $\leq 20\text{ mA}$ (Uprox+, Uprox 3) <p>Time Delay Before Availability: $\leq 8\text{ ms}$</p>	<p>Power-On Effect: Per IEC 947-5-2 Incorporated</p> <p>Reverse Polarity Protection: Incorporated Per EN 60947-5-2</p> <p>Wire-Break Protection: $\leq \pm 10\%$ 30 g, 11 ms 55 Hz, 1 mm</p> <p>Transient Protection: Amplitude in all 3 Planes $\leq 2\%$ of Rated Operating Distance</p> <p>Temperature Drift: Rated Operating Distance</p> <p>Shock:</p> <p>Vibration:</p> <p>Repeatability:</p>	
A3	2-wire DC - (AD, RD, AG)	
<p>Ripple: $\leq 10\%$</p> <p>Differential Travel (Hysteresis): 3-15% (5% typical)</p> <p>Voltage Drop Across Conducting Sensor:</p> <ul style="list-style-type: none"> Non-polarized (AD) $< 5.0\text{ V}$ Polarized (AG) $\leq 4.2\text{ V}$ <p>Trigger Current for Short Circuit Protection: $\geq 120\text{ mA}$</p> <p>Minimum Load Current: $\geq 3.0\text{ mA}$</p>	<p>Off-State (Leakage) Current: $\leq 0.8\text{ mA}$</p> <p>Power-On Effect: Per IEC 947-5-2</p> <p>Transient Protection: Per EN 60947-5-2</p> <p>Shock: 30 g, 11 ms</p> <p>Vibration: 55 Hz, 1 mm Amplitude in all 3 Planes</p> <p>Repeatability: $\leq 2\%$ of Rated Operating Distance</p>	

We reserve the right to make technical alterations without prior notice.

Weldguard | 8 mm

Nonembeddable Threaded Metal Barrels with Connector and DC Outputs

Part Number/ ID Number	Features	Sensing Range (mm)	Output	Voltage	Switching Freq. (Hz)	Operating Current (mA)	Operating Temp. (°C)	Protection	Housing	Front Cap/Face	Power LED	Wiring Diagrams	Dimension Drawings	Spec List	
NI6U-EGT08-AP6X-H1341/S1589 4635989	Uprox+, PTFE	6	3-wire DC PNP	10-30 VDC	1000	≤150	-25 to +70	IP68	TC	WG	N/A	YE	A	1	A2
NI6U-EG08-AN6X-H1341/S1589 46358050	Uprox+	6	3-wire DC NPN	10-30 VDC	1000	≤150	-25 to +70	IP68	SS	WG	N/A	YE	A	2	A2
NI4U-EG08-AP6X-H1341/S1589 46006401	Uprox	4	3-wire DC PNP	10-30 VDC	2000	≤150	-30 to +85	IP68	SS	WG	N/A	YE	A	1	A2
NI4-EG08-AG41X-H1341/S1589 4561091		4	2-wire DC	10-55 VDC	300	≤100	-25 to +70	IP67	SS	WG	N/A	YE	A	3	A3
NI3-EG08-AP6X-H1341/S1589 4602799		3	3-wire DC PNP	10-30 VDC	3000	≤150	-25 to +70	IP67	SS	WG	N/A	YE	A	1	A2

"/S1589" = Weldguard coating added to sensor.

We reserve the right to make technical alterations without prior notice.

Weldguard

Weldguard | 12 mm

Embeddable Threaded Metal Barrels 3-Wire DC Outputs

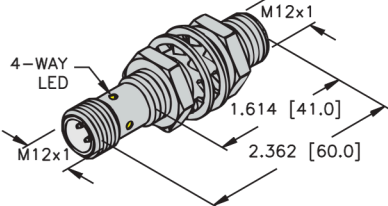
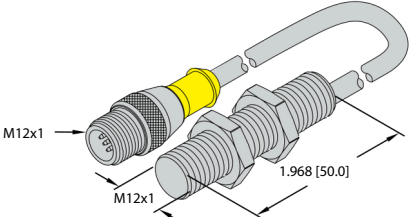
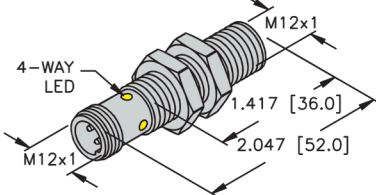
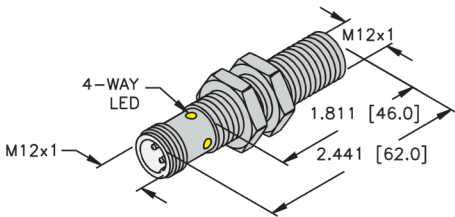
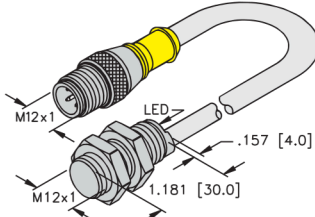
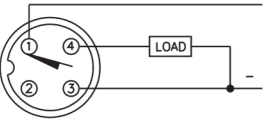
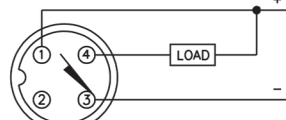
Housing Style	Dimension Drawings
	<p>A</p>  <p>12 mm - Embeddable, Stainless Steel Barrel, M12 Eurofast Connection</p>
<p>B</p>  <p>12 mm - Embeddable, Stainless Steel Barrel, M12 Eurofast Quick Disconnect</p>	<p>C</p>  <p>12 mm - Embeddable, M12 Eurofast Connection</p>
<p>D</p>  <p>12 mm - Embeddable, M12 Eurofast Connection, Extended Barrel Length</p>	<p>E</p>  <p>12 mm - Embeddable, M12 Eurofast Quick Disconnect</p>
Wiring Diagrams/Mating Cordsets	
<p>1</p>  <p>Mating Cordset: RK 4T-*; RKV 4T-*</p>	<p>2</p>  <p>Mating Cordset: RK 4T-*; RKV 4T-*</p>
A2 3 and 4-wire DC - (AN, RN, AP, RP, VN, VP)	
<p>Ripple: $\leq 10\%$</p> <p>Differential Travel (Hysteresis): 3-15% (5% typical)</p> <p>Voltage Drop Across Conducting Sensor: $\leq 1.8\text{ V}$</p> <p>Trigger Current for Short Circuit Protection: $\geq 220\text{ mA}$ on 200 mA Load Current $\geq 170\text{ mA}$ on 150 mA Load Current $\geq 120\text{ mA}$ on 100 mA Load Current</p> <p>Off-State (Leakage) Current: $\leq 0.1\text{ mA}$</p> <p>No-Load Current: $\leq 15\text{ mA}$ (Ferrite, Uprox, Rectangular) $\leq 20\text{ mA}$ (Uprox+, Uprox 3)</p> <p>Time Delay Before Availability: $\leq 8\text{ ms}$</p>	<p>Power-On Effect: Per IEC 947-5-2 Incorporated</p> <p>Reverse Polarity Protection: Incorporated Per EN 60947-5-2</p> <p>Wire-Break Protection: $\leq \pm 10\%$ 30 g, 11 ms 55 Hz, 1 mm</p> <p>Transient Protection: Amplitude in all 3 Planes $\leq 2\%$ of Rated Operating Distance</p> <p>Temperature Drift: Rated Operating Distance</p> <p>Shock:</p> <p>Vibration:</p> <p>Repeatability:</p>
A7 3-wire DC Stainless Front Face Ext Range (AP, AN, RP, RN)	
<p>Ripple: $\leq 10\%$</p> <p>Differential Travel (Hysteresis): 20%</p> <p>Voltage Drop Across Conducting Sensor: $\leq 2\text{ V}$</p> <p>Trigger Current for Short Circuit Protection: $\geq 220\text{ mA}$ on 200 mA Load Current</p> <p>No-Load Current: $\leq 10\text{ mA}$</p> <p>Off-State (Leakage) Current: $\leq 0.1\text{ mA}$</p>	<p>Temperature Drift: $\leq \pm 10\%$ Incorporated Incorporated 30</p> <p>Reverse Polarity Protection: g, 11 ms 55 Hz, 1 mm Amplitude, in all</p> <p>Wire-Break Protection: 3 Planes $\leq 5\%$ of Rated Operating</p> <p>Shock: Distance</p> <p>Vibration:</p> <p>Repeatability:</p>

We reserve the right to make technical alterations without prior notice.

Weldguard | 12 mm

Embeddable Threaded Metal Barrels 3-Wire DC Outputs

Part Number/ ID Number	Features	Sensing Range (mm)	Output	Voltage	Switching Freq. (Hz)	Operating Current (mA)	Operating Temp. (°C)	Protection	Housing	Front Cap/Face	Power LED	Output LED	Cable Length/Jacket	Wiring Diagrams Dimension Drawings	Spec List
BI6-EGT12FE-AP6X-H1141/S1589 46147061	SSF, PTFE	6	3-wire DC PNP	10-30 VDC	600	≤200	-25 to +70	IP68/69K	TC	WG	N/A	YE	--	A 1	A7
BI6-EGT12FE-AP6X-0.3-RS4T/S1589 46147200	SSF, PTFE	6	3-wire DC PNP	10-30 VDC	600	≤200	-25 to +70	IP68/69K	TC	WG	N/A	YE	0.3M/PVC	B 1	A7
BI4U-MT12-AP6X-H1141/S1589 1634997	Uprox+, PTFE	4	3-wire DC PNP	10-30 VDC	2000	≤200	-30 to +85	IP68	TC	WG	N/A	YE	--	C 1	A2
BI4U-MT12-AN6X-H1141/S1589 16348290	Uprox+, PTFE	4	3-wire DC NPN	10-30 VDC	2000	≤200	-30 to +85	IP68	TC	WG	N/A	YE	--	C 2	A2
BI4U-MT12E-AP6X2-H1141/S1589 1644797	Uprox+, PTFE	4	3-wire DC PNP	10-30 VDC	2000	≤200	-30 to +85	IP68	TC	WG	GN	YE	--	D 1	A2
BI4U-EM12-AP6X-H1141/S1589 16348971	Uprox+	4	3-wire DC PNP	10-30 VDC	2000	≤200	-30 to +85	IP68	SS	WG	N/A	YE	--	C 1	A2
BI4-MT12-AP6X-H1141/S1589 4607099	PTFE	4	3-wire DC PNP	10-30 VDC	2000	≤200	-25 to +70	IP67	TC	WG	N/A	YE	--	C 1	A2
BI4-MT12-AN6X-H1141/S1589 4607188	PTFE	4	3-wire DC NPN	10-30 VDC	2000	≤200	-25 to +70	IP67	TC	WG	N/A	YE	--	C 2	A2
BI4-MT12E-AP6X-H1141/S1589 4608094	PTFE	4	3-wire DC PNP	10-30 VDC	2000	≤200	-25 to +70	IP67	TC	WG	N/A	YE	--	D 1	A2
BI4-MT12E-AN6X-H1141/S1589 4607187	PTFE	4	3-wire DC NPN	10-30 VDC	2000	≤200	-25 to +70	IP67	TC	WG	N/A	YE	--	D 2	A2
BI4-EM12E-AP6X-H1141/S1589 4607184		4	3-wire DC PNP	10-30 VDC	2000	≤200	-25 to +70	IP67	SS	WG	N/A	YE	--	D 1	A2
BI4-EM12E-AN6X-H1141/S1589 4607185		4	3-wire DC NPN	10-30 VDC	2000	≤200	-25 to +70	IP67	SS	WG	N/A	YE	--	D 2	A2
BI3U-MT12-AP6X2-H1141/S1589 1634293	Uprox, PTFE	3	3-wire DC PNP	10-30 VDC	2000	≤200	-30 to +85	IP67	TC	WG	GN	YE	--	C 1	A2
BI3U-MT12-AP6X-H1141/S1589 16342121	Uprox, PTFE	3	3-wire DC PNP	10-30 VDC	2000	≤200	-30 to +85	IP67	TC	WG	N/A	YE	--	C 1	A2
BI3U-MT12E-AP6X2-H1141/S1589 1634291	Uprox, PTFE	3	3-wire DC PNP	10-30 VDC	2000	≤200	-30 to +85	IP67	TC	WG	GN	YE	--	D 1	A2
BI3U-MT12E-AN6X2-H1141/S1589 1634290	Uprox, PTFE	3	3-wire DC NPN	10-30 VDC	2000	≤200	-30 to +85	IP67	TC	WG	GN	YE	--	D 2	A2
BI3U-EM12HE-AP6X2-H1141/S1589 1634398	Uprox	3	3-wire DC PNP	10-30 VDC	3000	≤200	-30 to +85	IP68	SS	WG	GN	YE	--	D 1	A2
BI3U-EM12E-AN6X2-H1141/S1589 1634397	Uprox	3	3-wire DC NPN	10-30 VDC	3000	≤200	-30 to +85	IP68	SS	WG	GN	YE	--	D 2	A2
BI2-EG12K-AP6X-0.2-RS4T/S1589 4605193	Short Barrel	2	3-wire DC PNP	10-30 VDC	2000	≤200	-25 to +70	IP67	SS	WG	N/A	YE	0.2M/PVC	E 1	A2

We reserve the right to make technical alterations without prior notice.

Weldguard

"/S1589" = Weldguard coating added to sensor.

Weldguard | 12 mm

Embeddable Threaded Metal Barrels 2-Wire DC Outputs

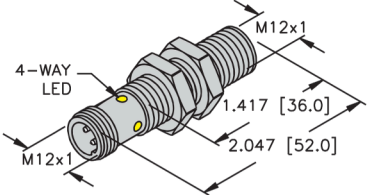
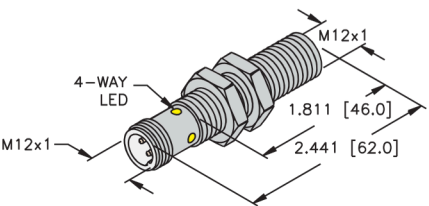
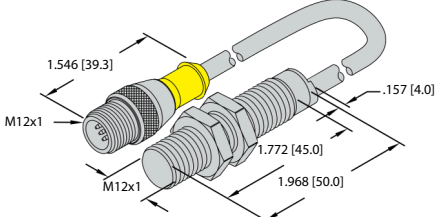
Housing Style	Dimension Drawings
	<p>A</p>  <p>12 mm - Embeddable, M12 Eurofast Connection</p>
<p>B</p>  <p>12 mm - Embeddable, M12 Eurofast Connection, Extended Barrel Length</p>	<p>C</p>  <p>12 mm - Embeddable, M12 Eurofast Quick Disconnect</p>

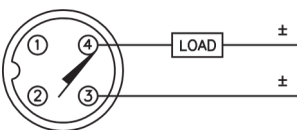
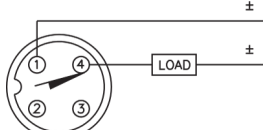
Wiring Diagrams/Mating Cordsets	
<p>1</p>  <p>Mating Cordset: RK 4.2T-*, RK 4.23T-*</p>	<p>2</p>  <p>Mating Cordset: RK 4.23T-*</p>

A3 2-wire DC - (AD, RD, AG)	
<p>Ripple: $\leq 10\%$</p> <p>Differential Travel (Hysteresis): 3-15% (5% typical)</p> <p>Voltage Drop Across Conducting Sensor: Non-polarized (AD) < 5.0 V Polarized (AG) ≤ 4.2 V</p> <p>Trigger Current for Short Circuit Protection: ≥ 120 mA</p> <p>Minimum Load Current: ≥ 3.0 mA</p>	<p>Off-State (Leakage) Current: ≤ 0.8 mA</p> <p>Power-On Effect: Per IEC 947-5-2</p> <p>Transient Protection: Per EN 60947-5-2</p> <p>Shock: 30 g, 11 ms</p> <p>Vibration: 55 Hz, 1 mm Amplitude in all 3 Planes</p> <p>Repeatability: $\leq 2\%$ of Rated Operating Distance</p>

We reserve the right to make technical alterations without prior notice.

Weldguard | 12 mm

Embeddable Threaded Metal Barrels 2-Wire DC Outputs

Part Number/ ID Number	Features	Sensing Range (mm)	Output	Voltage	Switching Freq. (Hz)	Operating Current (mA)	Operating Temp. (°C)	Protection	Housing	Front Cap/Face	Power LED	Output LED	Cable Length/Jacket	Wiring Diagrams Dimension Drawings	Spec List	
BI3-MT12-AD4X-H1141/S1589 4405082	PTFE	3	2-wire DC	10-65 VDC	1000	≤100	-25 to +70	IP67	TC	WG	N/A	YE	--	A	1	A3
BI3-MT12-AD4X-H1144/S1589 4405084	PTFE	3	2-wire DC	10-65 VDC	1000	≤100	-25 to +70	IP67	TC	WG	N/A	YE	--	A	1	A3
BI3-MT12E-AD4X-H1141/S1589 4405086	PTFE	3	2-wire DC	10-65 VDC	1000	≤100	-25 to +70	IP67	TC	WG	N/A	YE	--	B	1	A3
BI3-MT12E-AD4X-H1144/S1589 4405087	PTFE	3	2-wire DC	10-65 VDC	1000	≤100	-25 to +70	IP67	TC	WG	N/A	YE	--	B	2	A3
BI3-MT12-AD4X-0.3-RS4.23T/S1589 44050820	PTFE	3	2-wire DC	10-65 VDC	1000	≤100	-25 to +70	IP67	TC	WG	N/A	YE	0.3M/PVC	C	2	A3

"/S1589" = Weldguard coating added to sensor.

We reserve the right to make technical alterations without prior notice.

Weldguard

Weldguard | 12 mm

Nonembeddable Threaded Metal Barrels with Connector and DC Outputs

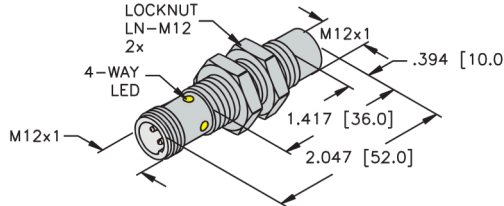
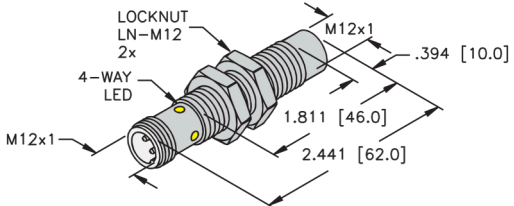
Housing Style	Dimension Drawings
	<p>A</p>  <p>12 mm - Nonembeddable, M12 Eurofast Connection</p>
<p>B</p>  <p>12 mm - Nonembeddable, Extended Barrel Length, M12 Eurofast Connection</p>	

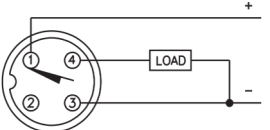
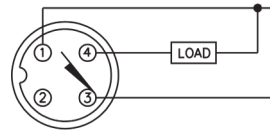
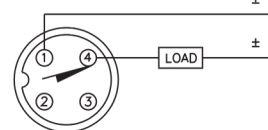
Wiring Diagrams/Mating Cordsets		
<p>1</p>  <p>Mating Cordset: RK 4T-*, RKV 4T-*</p>	<p>2</p>  <p>Mating Cordset: RK 4T-*, RKV 4T-*</p>	<p>3</p>  <p>Mating Cordset: RK 4.2T-*</p>

A2	3 and 4-wire DC - (AN, RN, AP, RP, VN, VP)	
<p>Ripple: $\leq 10\%$</p> <p>Differential Travel (Hysteresis): 3-15% (5% typical)</p> <p>Voltage Drop Across Conducting Sensor: $\leq 1.8\text{ V}$</p> <p>Trigger Current for Short Circuit Protection: $\geq 220\text{ mA}$ on 200 mA Load Current $\geq 170\text{ mA}$ on 150 mA Load Current $\geq 120\text{ mA}$ on 100 mA Load Current</p> <p>Off-State (Leakage) Current: $\leq 0.1\text{ mA}$</p> <p>No-Load Current: $\leq 15\text{ mA}$ (Ferrite, Uprox, Rectangular) $\leq 20\text{ mA}$ (Uprox+, Uprox 3)</p> <p>Time Delay Before Availability: $\leq 8\text{ ms}$</p>		<p>Power-On Effect: Per IEC 947-5-2 Incorporated</p> <p>Reverse Polarity Protection: Incorporated Per EN 60947-5-2</p> <p>Wire-Break Protection: $\leq \pm 10\%$ 30 g, 11 ms 55 Hz, 1 mm</p> <p>Transient Protection: Amplitude in all 3 Planes $\leq 2\%$ of Rated Operating Distance</p> <p>Temperature Drift: $\leq 2\%$ of Rated Operating Distance</p> <p>Shock:</p> <p>Vibration:</p> <p>Repeatability:</p>
A3	2-wire DC - (AD, RD, AG)	
<p>Ripple: $\leq 10\%$</p> <p>Differential Travel (Hysteresis): 3-15% (5% typical)</p> <p>Voltage Drop Across Conducting Sensor: Non-polarized (AD) $< 5.0\text{ V}$ Polarized (AG) $\leq 4.2\text{ V}$</p> <p>Trigger Current for Short Circuit Protection: $\geq 120\text{ mA}$</p> <p>Minimum Load Current: $\geq 3.0\text{ mA}$</p>		<p>Off-State (Leakage) Current: $\leq 0.8\text{ mA}$</p> <p>Power-On Effect: Per IEC 947-5-2</p> <p>Transient Protection: Per EN 60947-5-2</p> <p>Shock: 30 g, 11 ms</p> <p>Vibration: 55 Hz, 1 mm Amplitude in all 3 Planes</p> <p>Repeatability: $\leq 2\%$ of Rated Operating Distance</p>

We reserve the right to make technical alterations without prior notice.

Weldguard | 12 mm

Nonembeddable Threaded Metal Barrels with Connector and DC Outputs

Part Number/ ID Number	Features	Sensing Range (mm)	Output	Voltage	Switching Freq. (Hz)	Operating Current (mA)	Operating Temp. (°C)	Protection	Housing	Front Cap/Face	Power LED	Wiring Diagrams		Dimension Drawings	Spec List
NI10U-MT12E-AP6X2-H1141/S1589 1634994	Uprox+, PTFE	10	3-wire DC PNP	10-30 VDC	1000	≤200	-30 to +85	IP68	TC	WG	GN	YE	B	1	A2
NI10U-MT12-AP6X-H1141/S1589 16348101	Uprox+, PTFE	10	3-wire DC PNP	10-30 VDC	1000	≤200	-30 to +85	IP68	TC	WG	N/A	YE	A	1	A2
NI8U-MT12-AP6X2-H1141/S1589 1644292	Uprox, PTFE	8	3-wire DC PNP	10-30 VDC	2000	≤200	-30 to +85	IP67	TC	WG	GN	YE	A	1	A2
NI8U-MT12E-AP6X2-H1141/S1589 1644299	Uprox, PTFE	8	3-wire DC PNP	10-30 VDC	2000	≤200	-30 to +85	IP67	TC	WG	GN	YE	B	1	A2
NI8U-MT12E-AN6X2-H1141/S1589 16442480	Uprox, PTFE	8	3-wire DC NPN	10-30 VDC	2000	≤200	-30 to +85	IP67	TC	WG	GN	YE	B	2	A2
NI8U-EM12E-AP6X2-H1141/S1589 1644392	Uprox	8	3-wire DC PNP	10-30 VDC	2000	≤200	-30 to +85	IP68	SS	WG	GN	YE	B	1	A2
NI8U-EM12E-AN6X2-H1141/S1589 1644391	Uprox	8	3-wire DC NPN	10-30 VDC	2000	≤200	-30 to +85	IP68	SS	WG	GN	YE	B	2	A2
NI8-MT12E-AP6X-H1141/S1589 4611398	PTFE	8	3-wire DC PNP	10-30 VDC	2000	≤200	-25 to +70	IP67	TC	WG	N/A	YE	B	1	A2
NI8-MT12E-AN6X-H1141/S1589 4611397	PTFE	8	3-wire DC NPN	10-30 VDC	2000	≤200	-25 to +70	IP67	TC	WG	N/A	YE	B	2	A2
NI8-EM12E-AP6X-H1141/S1589 4611396		8	3-wire DC PNP	10-30 VDC	2000	≤200	-25 to +70	IP67	SS	WG	N/A	YE	B	1	A2
NI8-MT12-AD4X-H1141/S1589 4411291	PTFE	8	2-wire DC	10-65 VDC	1000	≤100	-25 to +70	IP67	TC	WG	N/A	YE	A	3	A3

"/S1589" = Weldguard coating added to sensor.

We reserve the right to make technical alterations without prior notice.

Weldguard

Weldguard | 12 mm

Threaded Metal Barrels with Connector and AC/DC Outputs

Housing Style	Dimension Drawings
	<p>A</p> <p>12 mm - Embeddable, 1/2" Microfast Connection</p>
<p>B</p> <p>12 mm - Nonembeddable, 1/2" Microfast Connection</p>	

Wiring Diagrams/Mating Cordsets

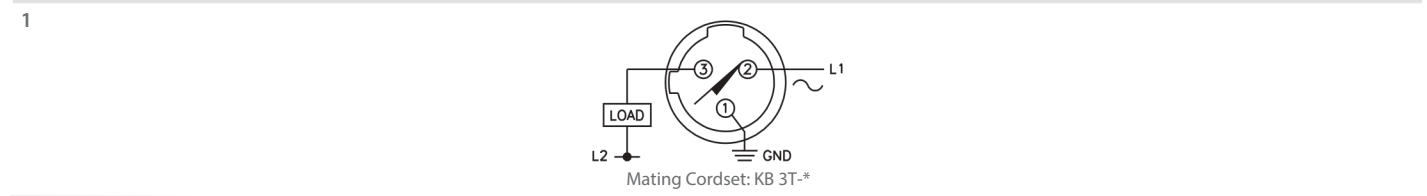

A4 2-wire AC/DC w/ Short-Circuit Protection - (ADZ, RDZ, FDZ, VDZ)	
<p>Line Frequency: $\geq 50 \dots \leq 60$ Hz</p> <p>Differential Travel (Hysteresis): 3-15% (5% typical)</p> <p>Voltage Drop Across Conducting Sensor: ≤ 6.0 V</p> <p>Trigger Current for Short Circuit Protection: AC: ≥ 440 mA; DC: ≥ 330 mA AC: ≥ 120 mA; DC: ≥ 120 mA</p> <p>Continuous Load Current: AC: ≤ 400 mA; DC: ≤ 300 mA AC: ≤ 100 mA; DC: ≤ 100 mA</p> <p>Off-State (leakage) Current: ≤ 1.7 mA (AC) ≤ 1.5 mA (DC)</p>	<p>Minimum Load Current: ≥ 3.0 mA</p> <p>Inrush Current: ≤ 3 A (≤ 20 ms, max 5 Hz)</p> <p>Power-On Effect: Per IEC 947-5-2</p> <p>Transient Protection: Per EN 60947-5-2</p> <p>Shock: 30 g, 11 ms</p> <p>Vibration: 55 Hz, 1 mm Amplitude, in all 3 Planes</p> <p>Repeatability: $\leq 2\%$ of Rated Operating Distance</p>

We reserve the right to make technical alterations without prior notice.

Weldguard | 12 mm

Threaded Metal Barrels with Connector and AC/DC Outputs

Part Number/ ID Number	Features	Sensing Range (mm)	Output	Voltage	Switching Freq. (Hz)	Operating Current (mA)	Operating Temp. (°C)	Protection	Housing	Front Cap/Face	Power LED	Output LED	Dimension Drawings	Wiring Diagrams	Spec List
BI4- GT12-ADZ32X-B3131/S1589 4205087	PTFE	4	2-wire AC/DC	20-250 VAC/10-300 VDC	20	≤100	-25 to +70	IP67	TC	WG	N/A	RD	A	1	A4
BI2- GT12-ADZ32X-B3131/S34/S1589 4205096	PTFE, WFI	2	2-wire AC/DC	20-250 VAC/10-300 VDC	20	≤100	-25 to +70	IP67	TC	WG	N/A	RD	A	1	A4
NI8- GT12-ADZ32X-B3131/S1589 42054801	PTFE	8	2-wire AC/DC	20-250 VAC/10-300 VDC	20	≤100	-25 to +70	IP67	TC	WG	N/A	RD	B	1	A4
NI4- GT12-ADZ32X-B3131/S34/S1589 4205293	PTFE, WFI	4	2-wire AC/DC	20-250 VAC/10-300 VDC	20	≤100	-25 to +70	IP67	TC	WG	N/A	RD	B	1	A4

"/S1589" = Weldguard coating added to sensor.

We reserve the right to make technical alterations without prior notice.

Weldguard

Weldguard | 18 mm

Embeddable Threaded Metal Barrels with Connector and DC Outputs

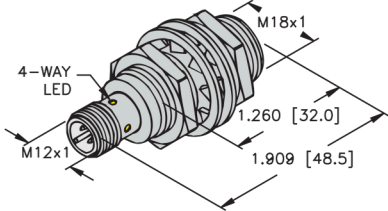
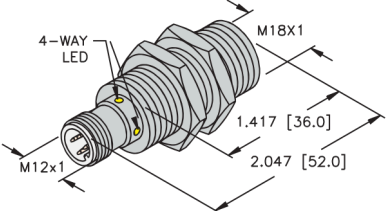
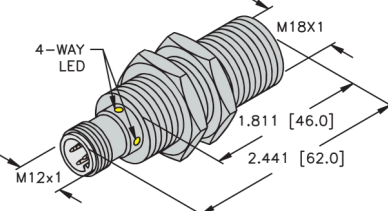
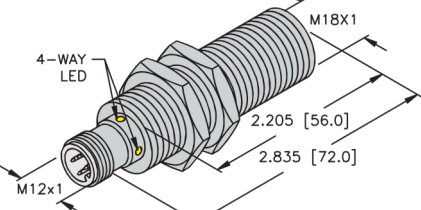
Housing Style	Dimension Drawings
	<p>A</p>  <p>18 mm - Embeddable, Stainless Steel Barrel, M12 Eurofast Connection</p>
<p>B</p>  <p>18 mm - Embeddable M12 Eurofast Connection</p>	<p>C</p>  <p>18 mm - Embeddable M12 Eurofast Connection</p>
<p>D</p>  <p>18 mm - Embeddable, Ext. Barrel Length, M12 Eurofast Connection</p>	

Wiring Diagrams/Mating Cordsets

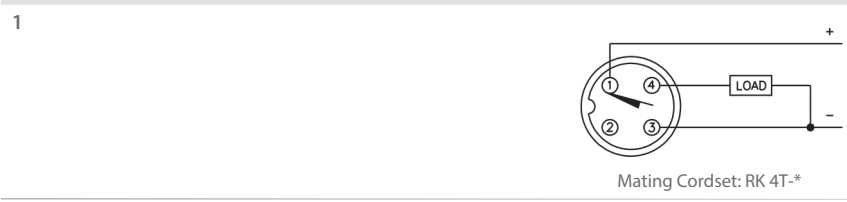

A2 3 and 4-wire DC - (AN, RN, AP, RP, VN, VP)

<p>Ripple: $\leq 10\%$</p> <p>Differential Travel (Hysteresis): 3-15% (5% typical)</p> <p>Voltage Drop Across Conducting Sensor: $\leq 1.8\text{ V}$</p> <p>Trigger Current for Short Circuit Protection: $\geq 220\text{ mA}$ on 200 mA Load Current $\geq 170\text{ mA}$ on 150 mA Load Current $\geq 120\text{ mA}$ on 100 mA Load Current</p> <p>Off-State (Leakage) Current: $\leq 0.1\text{ mA}$</p> <p>No-Load Current: $\leq 15\text{ mA}$ (Ferrite, Uprox, Rectangular) $\leq 20\text{ mA}$ (Uprox+, Uprox 3)</p> <p>Time Delay Before Availability: $\leq 8\text{ ms}$</p>	<p>Power-On Effect: Per IEC 947-5-2 Incorporated</p> <p>Reverse Polarity Protection: Incorporated Per EN 60947-5-2</p> <p>Wire-Break Protection: $\leq \pm 10\%$ 30 g, 11 ms 55 Hz, 1 mm</p> <p>Transient Protection: Amplitude in all 3 Planes $\leq 2\%$ of Rated Operating Distance</p> <p>Temperature Drift:</p> <p>Shock:</p> <p>Vibration:</p> <p>Repeatability:</p>
--	--

A7 3-wire DC Stainless Front Face Ext Range (AP, AN, RP, RN)

<p>Ripple: $\leq 10\%$</p> <p>Differential Travel (Hysteresis): 20%</p> <p>Voltage Drop Across Conducting Sensor: $\leq 2\text{ V}$</p> <p>Trigger Current for Short Circuit Protection: $\geq 220\text{ mA}$ on 200 mA Load Current</p> <p>No-Load Current: $\leq 10\text{ mA}$</p> <p>Off-State (Leakage) Current: $\leq 0.1\text{ mA}$</p>	<p>Temperature Drift: $\leq \pm 10\%$ Incorporated Incorporated 30 g, 11 ms 55 Hz, 1 mm Amplitude, in all 3 Planes $\leq 5\%$ of Rated Operating Distance</p> <p>Shock:</p> <p>Vibration:</p> <p>Repeatability:</p>
--	---

We reserve the right to make technical alterations without prior notice.

Weldguard | 18 mm

Embeddable Threaded Metal Barrels with Connector and DC Outputs

Part Number/ ID Number	Features	Sensing Range (mm)	Output	Voltage	Switching Freq. (Hz)	Operating Current (mA)	Operating Temp. (°C)	Protection	Housing	Front Cap/Face	Power LED	Output LED	Dimension Drawings	Wiring Diagrams	Spec List
BI10-EGT18F-AP6X-H1141/S1589 46147081	SSF, PTFE	10	3-wire DC PNP	10-30 VDC	200	≤200	-25 to +70	IP68/69K	TC	WG	N/A	YE	A	1	A7
BI8U-MT18M-AP6X2-H1141/S1589 16447411	Uprox+, PTFE	8	3-wire DC PNP	10-30 VDC	1500	≤200	-30 to +85	IP68	TC	WG	GN	YE	C	1	A2
BI8U-MT18-AP6X-H1141/S1589 1644789	Uprox+, PTFE	8	3-wire DC PNP	10-30 VDC	1500	≤200	-30 to +85	IP68	TC	WG	N/A	YE	B	1	A2
BI8U-EM18M-AP6X2-H1141/S1589 1644771	Uprox+	8	3-wire DC PNP	10-30 VDC	1500	≤200	-30 to +85	IP68	SS	WG	GN	YE	C	1	A2
BI8-EM18-AP6X-H1141/S1589 4615099		8	3-wire DC PNP	10-30 VDC	500	≤200	-25 to +70	IP67	SS	WG	N/A	YE	B	1	A2
BI8-EM18E-AP6X-H1141/S1589 4615096		8	3-wire DC PNP	10-30 VDC	500	≤200	-25 to +70	IP67	SS	WG	N/A	YE	D	1	A2
BI5U-MT18-AP6X2-H1141/S395/S1589 1635291	Uprox, PTFE	5	3-wire DC PNP	10-30 VDC	2500	≤200	-30 to +85	IP67	TC	WG	GN	YE	C	1	A2
BI5U-MT18-AP6X-H1141/S1589 1635294	Uprox, PTFE	5	3-wire DC PNP	10-30 VDC	2500	≤200	-30 to +85	IP67	TC	WG	N/A	YE	B	1	A2
BI5U-MT18-AP6X2-H1141/S1589 1635292	Uprox, PTFE	5	3-wire DC PNP	10-30 VDC	2500	≤200	-30 to +85	IP67	TC	WG	GN	YE	B	1	A2
BI5U-EM18-AP6X2-H1141/S395/S1589 1635197	Uprox	5	3-wire DC PNP	10-30 VDC	2500	≤200	-30 to +85	IP68	SS	WG	GN	YE	C	1	A2

"/S1589" = Weldguard coating added to sensor.

We reserve the right to make technical alterations without prior notice.

Weldguard

Weldguard | 18 mm

Embeddable Threaded Metal Barrels 2-Wire DC Outputs

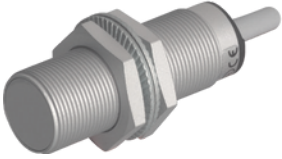
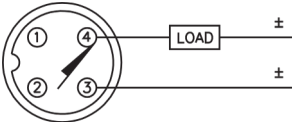
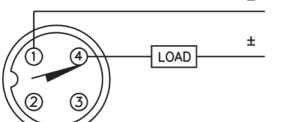
Housing Style	Dimension Drawings
	<p>A</p> <p>18 mm - Embeddable M12 Eurofast Connection</p>
<p>B</p> <p>18 mm - Embeddable, Ext. Barrel Length, M12 Eurofast Connection</p>	<p>C</p> <p>18 mm - Embeddable, Short Barrel Length, M12 Eurofast Quick Disconnect</p>
<p>D</p> <p>18 mm - Embeddable, Ext. Barrel Length, M12 Eurofast Quick Disconnect</p>	
Wiring Diagrams/Mating Cordsets	
<p>1</p>  <p>Mating Cordset: RK 4.2T-*</p>	<p>2</p>  <p>Mating Cordset: RK 4.23T-*</p>
A3 2-wire DC - (AD, RD, AG)	
<p>Ripple: $\leq 10\%$</p> <p>Differential Travel (Hysteresis): 3-15% (5% typical)</p> <p>Voltage Drop Across Conducting Sensor: Non-polarized (AD) < 5.0 V Polarized (AG) ≤ 4.2 V</p> <p>Trigger Current for Short Circuit Protection: ≥ 120 mA</p> <p>Minimum Load Current: ≥ 3.0 mA</p>	<p>Off-State (Leakage) Current: ≤ 0.8 mA</p> <p>Power-On Effect: Per IEC 947-5-2</p> <p>Transient Protection: Per EN 60947-5-2</p> <p>Shock: 30 g, 11 ms</p> <p>Vibration: 55 Hz, 1 mm Amplitude in all 3 Planes</p> <p>Repeatability: $\leq 2\%$ of Rated Operating Distance</p>

We reserve the right to make technical alterations without prior notice.

Weldguard | 18 mm

Embeddable Threaded Metal Barrels 2-Wire DC Outputs

Part Number/ ID Number	Features	Sensing Range (mm)	Output	Voltage	Switching Freq. (Hz)	Operating Current (mA)	Operating Temp. (°C)	Protection	Housing	Front Cap/Face	Power LED	Output LED	Cable Length/Jacket	Wiring Diagrams Dimension Drawings	Spec List	
BI7-MT18-AD4X-H1144/S1589 4414576	PTFE	7	2-wire DC	10-65 VDC	1000	≤100	-25 to +70	IP67	TC	WG	N/A	YE	--	A	2	A3
BI7-MT18E-AD4X-H1141/S1589 4414588	PTFE	7	2-wire DC	10-65 VDC	1000	≤100	-25 to +70	IP67	TC	WG	N/A	YE	--	B	1	A3
BI7-MT18E-AD4X-H1144/S1589 4414599	PTFE	7	2-wire DC	10-65 VDC	1000	≤100	-25 to +70	IP67	TC	WG	N/A	YE	--	B	2	A3
BI7-GT18K-AD4X-0.2-RS4.23T/S1589 44145922	PTFE, Short Barrel	7	2-wire DC	10-65 VDC	1000	≤100	-25 to +70	IP67	TC	WG	N/A	YE	0.2M/PVC	C	2	A3
BI7-MT18E-AD4X-0.3-RS4.23T/S1589 4414589	PTFE	7	2-wire DC	10-65 VDC	1000	≤100	-25 to +70	IP67	TC	WG	N/A	YE	0.3M/PVC	D	2	A3

"/S1589" = Weldguard coating added to sensor.

We reserve the right to make technical alterations without prior notice.

Weldguard

Weldguard | 18 mm

Nonembeddable Threaded Metal Barrels with Connector and DC Outputs

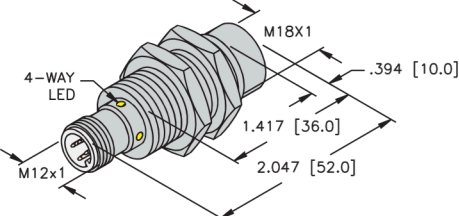
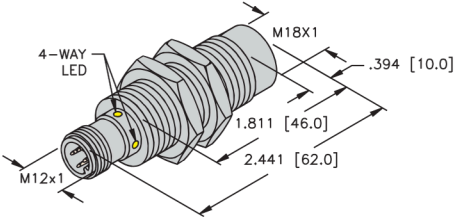
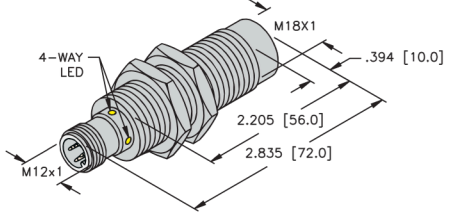
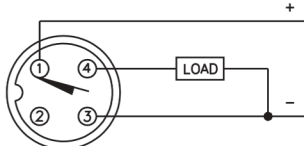
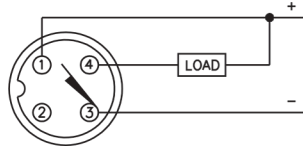
Housing Style	Dimension Drawings
	<p>A</p>  <p>18 mm - Nonembeddable, M12 Eurofast Connection</p>
<p>B</p>  <p>18 mm - Nonembeddable, M12 Eurofast Connection</p>	<p>C</p>  <p>18 mm - Nonembeddable, Ext. Barrel Length M12 Eurofast Connection</p>
Wiring Diagrams/Mating Cordsets	
<p>1</p>  <p>Mating Cordset: RK 4T-*, RKV 4T-*</p>	<p>2</p>  <p>Mating Cordset: RK 4T-*, RKV 4T-*</p>
A2 3 and 4-wire DC - (AN, RN, AP, RP, VN, VP)	
<p>Ripple: $\leq 10\%$</p> <p>Differential Travel (Hysteresis): 3-15% (5% typical)</p> <p>Voltage Drop Across Conducting Sensor: $\leq 1.8\text{ V}$</p> <p>Trigger Current for Short Circuit Protection:</p> <ul style="list-style-type: none"> $\geq 220\text{ mA}$ on 200 mA Load Current $\geq 170\text{ mA}$ on 150 mA Load Current $\geq 120\text{ mA}$ on 100 mA Load Current <p>Off-State (Leakage) Current: $\leq 0.1\text{ mA}$</p> <p>No-Load Current: $\leq 15\text{ mA}$ (Ferrite, Uprox, Rectangular)</p> <p>$\leq 20\text{ mA}$ (Uprox+, Uprox 3)</p> <p>Time Delay Before Availability: $\leq 8\text{ ms}$</p>	<p>Power-On Effect: Per IEC 947-5-2 Incorporated</p> <p>Reverse Polarity Protection: Incorporated Per EN 60947-5-2</p> <p>Wire-Break Protection: $\leq \pm 10\%$ 30 g, 11 ms 55 Hz, 1 mm</p> <p>Transient Protection: Amplitude in all 3 Planes $\leq 2\%$</p> <p>Temperature Drift: Rated Operating Distance</p> <p>Shock:</p> <p>Vibration:</p> <p>Repeatability:</p>

We reserve the right to make technical alterations without prior notice.

Weldguard | 18 mm

Nonembeddable Threaded Metal Barrels with Connector and DC Outputs

Part Number/ ID Number	Features	Sensing Range (mm)	Output	Voltage	Switching Freq. (Hz)	Operating Current (mA)	Operating Temp. (°C)	Protection	Housing	Front Cap/Face	Power LED	Output LED	Cable Length/Jacket	Dimension Drawings	Wiring Diagrams	Spec List
NI15U-MT18-AP6X-H1141/S1589 16353331	Uprox+, PTFE	15	3-wire DC PNP	10-30 VDC	1500	≤200	-30 to +85	IP68	TC	WG	N/A	YE		A	1	A2
NI15U-MT18-AN6X-H1141/S1589 16353370	Uprox+, PTFE	15	3-wire DC NPN	10-30 VDC	1500	≤200	-30 to +85	IP68	TC	WG	N/A	YE		A	2	A2
NI15U-MT18M-AP6X2-H1141/S1589 16352920	Uprox+, PTFE	15	3-wire DC PNP	10-30 VDC	1500	≤200	-30 to +85	IP68	TC	WG	GN	YE		B	1	A2
NI14-MT18E-AP6X-H1141/S1589 4611497	PTFE	14	3-wire DC PNP	10-30 VDC	1000	≤200	-25 to +70	IP67	TC	WG	N/A	YE		C	1	A2
NI14-EM18E-AP6X-H1141/S1589 4611495		14	3-wire DC PNP	10-30 VDC	1000	≤200	-25 to +70	IP67	SS	WG	N/A	YE		C	1	A2
NI12U-MT18-AP6X2-H1141/S395/S1589 1645291	Uprox, PTFE	12	3-wire DC PNP	10-30 VDC	1500	≤200	-30 to +85	IP67	TC	WG	GN	YE		B	1	A2
NI12U-MT18-AP6X2-H1141/S1589 1645293	Uprox, PTFE	12	3-wire DC PNP	10-30 VDC	1500	≤200	-30 to +85	IP67	TC	WG	GN	YE		A	1	A2
NI12U-EM18-AP6X2-H1141/S395/S1589 1645292	Uprox, PTFE	12	3-wire DC PNP	10-30 VDC	1500	≤200	-30 to +85	IP67	TC	WG	N/A	YE		A	1	A2
NI12U-EM18-AN6X2-H1141/S395/S1589 1645491	Uprox	12	3-wire DC PNP	10-30 VDC	2000	≤200	-30 to +85	IP68	SS	WG	GN	YE		B	1	A2
NI12U-EM18-AN6X2-H1141/S395/S1589 1645490	Uprox	12	3-wire DC NPN	10-30 VDC	2000	≤200	-30 to +85	IP68	SS	WG	GN	YE		B	2	A2

"/S1589" = Weldguard coating added to sensor.

We reserve the right to make technical alterations without prior notice.

Weldguard

Weldguard | 18 mm

Threaded Metal Barrels with Connector and AC/DC Outputs

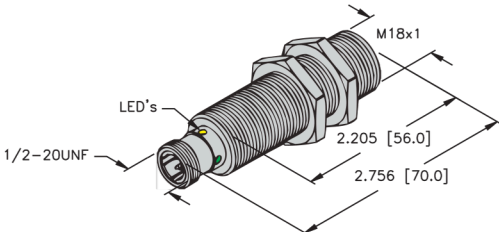
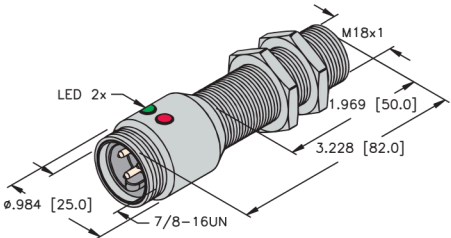
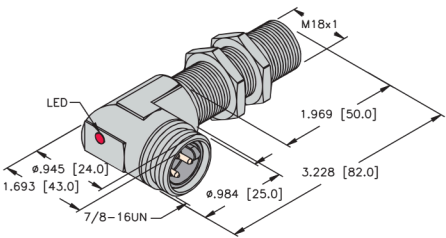
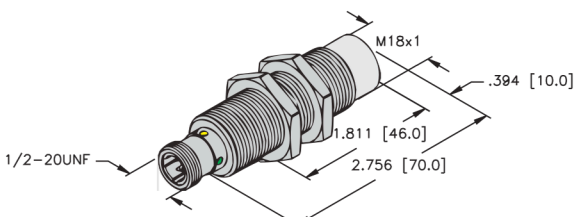
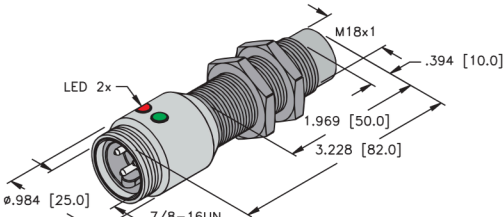
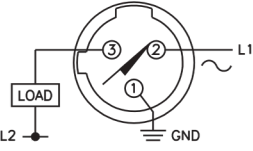
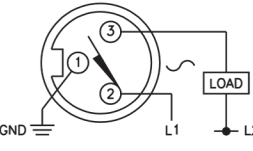
Housing Style	Dimension Drawings
	<p>A</p>  <p>18 mm - Embeddable, 1/2" Microfast Connection</p>
<p>B</p>  <p>18 mm - Embeddable, 7/8" Minifast Connection</p>	<p>C</p>  <p>18 mm - Embeddable, 7/8" Minifast Right Angle Connection</p>
<p>D</p>  <p>18 mm - Nonembeddable, 1/2" Microfast connection</p>	<p>E</p>  <p>18 mm - Nonembeddable 7/8" Minifast Connection</p>
Wiring Diagrams/Mating Cordsets	
<p>1</p>  <p>Mating Cordset: KB 3T-*</p>	<p>2</p>  <p>Mating Cordset: RKM 30-*M</p>
A4 2-wire AC/DC w/ Short-Circuit Protection - (ADZ, RDZ, FDZ, VDZ)	
<p>Line Frequency: $\geq 50 \dots \leq 60$ Hz</p> <p>Differential Travel (Hysteresis): 3-15% (5% typical)</p> <p>Voltage Drop Across Conducting Sensor: ≤ 6.0 V</p> <p>Trigger Current for Short Circuit Protection: AC: ≥ 440 mA; DC: ≥ 330 mA AC: ≥ 120 mA; DC: ≥ 120 mA</p> <p>Continuous Load Current: AC: ≤ 400 mA; DC: ≤ 300 mA AC: ≤ 100 mA; DC: ≤ 100 mA</p> <p>Off-State (leakage) Current: ≤ 1.7 mA (AC) ≤ 1.5 mA (DC)</p>	<p>Minimum Load Current: ≥ 3.0 mA</p> <p>Inrush Current: ≤ 3 A (≤ 20 ms, max 5 Hz)</p> <p>Power-On Effect: Per IEC 947-5-2</p> <p>Transient Protection: Per EN 60947-5-2</p> <p>Shock: 30 g, 11 ms</p> <p>Vibration: 55 Hz, 1 mm Amplitude, in all 3 Planes</p> <p>Repeatability: $\leq 2\%$ of Rated Operating Distance</p>

We reserve the right to make technical alterations without prior notice.

Weldguard | 18 mm

Threaded Metal Barrels with Connector and AC/DC Outputs

Part Number/ ID Number	Features	Sensing Range (mm)	Output	Voltage	Switching Freq. (Hz)	Operating Current (mA)	Operating Temp. (°C)	Protection	Housing	Front Cap/Face	Power LED	Output LED	Dimension Drawings	Wiring Diagrams	Spec List
BI5- GT18-ADZ30X2-B3331/S34/S1589 4255283	PTFE, WFI	5	2-wire AC/DC Short-Circuit Protected	20-250 VAC/10-300 VDC	20	≤400/300	-25 to +70	IP67	TC	WG	GN	RD	A	1	A4
BI5- GT18-ADZ30X2-B1331/S34/S1589 4255284	PTFE, WFI	5	2-wire AC/DC Short-Circuit Protected	20-250 VAC/10-300 VDC	20	≤400/300	-25 to +70	IP67	TC	WG	GN	RD	B	2	A4
BI5- GT18-ADZ30X2-B1431/S34/S1589 4255285	PTFE, WFI	5	2-wire AC/DC Short-Circuit Protected	20-250 VAC/10-300 VDC	20	≤400/300	-25 to +70	IP67	TC	WG	GN	RD	C	2	A4
NI14- GT18-ADZ30X2-B3331/S1589 4205491	PTFE	14	2-wire AC/DC Short-Circuit Protected	20-250 VAC/10-300 VDC	20	≤400/300	-25 to +70	IP67	TC	WG	GN	RD	D	1	A4
NI14- GT18-ADZ30X2-B1331/S1589 4205484	PTFE	14	2-wire AC/DC Short-Circuit Protected	20-250 VAC/10-300 VDC	20	≤400/300	-25 to +70	IP67	TC	WG	GN	RD	E	2	A4
NI8- GT18-ADZ30X2-B3331/S34/S1589 4208891	PTFE, WFI	8	2-wire AC/DC Short-Circuit Protected	20-250 VAC/10-300 VDC	20	≤400/300	-25 to +70	IP67	TC	WG	GN	RD	D	1	A4
NI8- GT18-ADZ30X2-B1331/S34/S1589 4208890	PTFE, WFI	8	2-wire AC/DC Short-Circuit Protected	20-250 VAC/10-300 VDC	20	≤400/300	-25 to +70	IP67	TC	WG	GN	RD	E	2	A4

"S1589" = Weldguard coating added to sensor.

We reserve the right to make technical alterations without prior notice.

Weldguard

Weldguard | 30 mm

Threaded Metal Barrels with Connector and DC Outputs

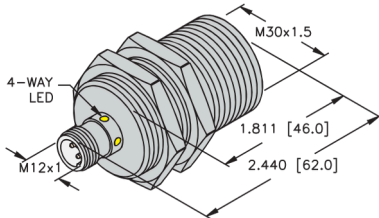
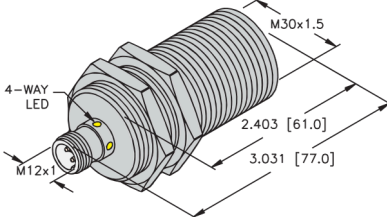
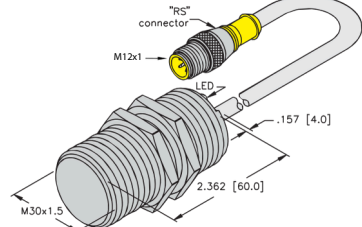
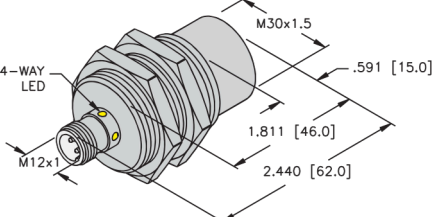
Housing Style	Dimension Drawings
	<p>A</p>  <p>30 mm - Embeddable, M12 Eurofast Connection</p>
<p>B</p>  <p>30 mm - Embeddable, M12 Eurofast Connection, Extended Barrel Length</p>	<p>C</p>  <p>30 mm - Embeddable, Potted-in Cable, Eurofast Quick Disconnect</p>
<p>D</p>  <p>30 mm - Nonembeddable, M12 Eurofast Connection</p>	

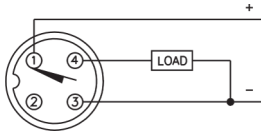
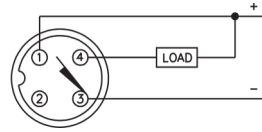
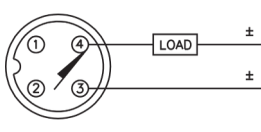
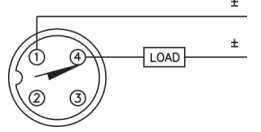
Wiring Diagrams/Mating Cordsets			
<p>1</p>  <p>Mating Cordset: RK 4T-*, RKV 4T-*</p>	<p>2</p>  <p>Mating Cordset: RK 4T-*, RKV 4T-*</p>	<p>3</p>  <p>Mating Cordset: RK 4.2T-*</p>	<p>4</p>  <p>Mating Cordset: RK 4.23T-*</p>

A2	3 and 4-wire DC - (AN, RN, AP, RP, VN, VP)	
<p>Ripple: $\leq 10\%$</p> <p>Differential Travel (Hysteresis): 3-15% (5% typical)</p> <p>Voltage Drop Across Conducting Sensor: $\leq 1.8\text{ V}$</p> <p>Trigger Current for Short Circuit Protection: $\geq 220\text{ mA}$ on 200 mA Load Current $\geq 170\text{ mA}$ on 150 mA Load Current $\geq 120\text{ mA}$ on 100 mA Load Current</p> <p>Off-State (Leakage) Current: $\leq 0.1\text{ mA}$</p> <p>No-Load Current: $\leq 15\text{ mA}$ (Ferrite, Uprox, Rectangular) $\leq 20\text{ mA}$ (Uprox+, Uprox 3)</p> <p>Time Delay Before Availability: $\leq 8\text{ ms}$</p>		<p>Power-On Effect: Per IEC 947-5-2 Incorporated</p> <p>Reverse Polarity Protection: Incorporated Per EN 60947-5-2</p> <p>Wire-Break Protection: $\leq \pm 10\%$ 30 g, 11 ms 55 Hz, 1 mm</p> <p>Transient Protection: Amplitude in all 3 Planes $\leq 2\%$ of Rated Operating Distance</p> <p>Temperature Drift:</p> <p>Shock:</p> <p>Vibration:</p> <p>Repeatability:</p>
A3	2-wire DC - (AD, RD, AG)	
<p>Ripple: $\leq 10\%$</p> <p>Differential Travel (Hysteresis): 3-15% (5% typical)</p> <p>Voltage Drop Across Conducting Sensor: Non-polarized (AD) $< 5.0\text{ V}$ Polarized (AG) $\leq 4.2\text{ V}$</p> <p>Trigger Current for Short Circuit Protection: $\geq 120\text{ mA}$</p> <p>Minimum Load Current: $\geq 3.0\text{ mA}$</p>		<p>Off-State (Leakage) Current: $\leq 0.8\text{ mA}$</p> <p>Power-On Effect: Per IEC 947-5-2</p> <p>Transient Protection: Per EN 60947-5-2</p> <p>Shock: 30 g, 11 ms</p> <p>Vibration: 55 Hz, 1 mm Amplitude in all 3 Planes</p> <p>Repeatability: $\leq 2\%$ of Rated Operating Distance</p>

We reserve the right to make technical alterations without prior notice.

Weldguard | 30 mm

Threaded Metal Barrels with Connector and DC Outputs

Part Number/ ID Number	Features	Sensing Range (mm)	Output	Voltage	Switching Freq. (Hz)	Operating Current (mA)	Operating Temp. (°C)	Protection	Housing	Front Cap/Face	Power LED	Output LED	Cable Length/Jacket	Wiring Diagrams Dimension Drawings	Spec List
BI15U-MT30-AP6X-H1141/S1589 1636793	Uprox+, PTFE	15	3-wire DC PNP	10-30 VDC	1000	≤200	-30 to +85	IP68	TC	WG	N/A	YE	--	A 1	A2
BI15-EM30-AP6X-H1141/S1589 4618593		15	3-wire DC PNP	10-30 VDC	300	≤200	-25 to +70	IP67	SS	WG	N/A	YE	--	A 1	A2
BI15-EM30E-AP6X-H1141/S1589 4618587		15	3-wire DC PNP	10-30 VDC	300	≤200	-25 to +70	IP67	SS	WG	N/A	YE	--	B 1	A2
BI12-GT30-AD4X-0.3-RS4.2T/S1589 4417086	PTFE	12	2-wire DC	10-65 VDC	500	≤100	-25 to +70	IP67	TC	WG	N/A	YE	0.3M/PVC	C 3	A3
BI12-GT30-AD4X-0.3-RS4.23T/S1589 4417085	PTFE	12	2-wire DC	10-65 VDC	500	≤100	-25 to +70	IP67	TC	WG	N/A	YE	0.3M/PVC	C 4	A3
BI10U-MT30-AP6X2-H1141/S1589 1636291	Uprox, PTFE	10	3-wire DC PNP	10-30 VDC	1000	≤200	-30 to +85	IP67	TC	WG	GN	YE	--	A 1	A2
NI30U-MT30-AP6X2-H1141/S1589 16466351	Uprox+, PTFE	30	3-wire DC PNP	10-30 VDC	1000	≤200	-30 to +85	IP68	TC	WG	GN	YE	--	D 1	A2
NI20U-EM30-AP6X2-H1141/S1589 1646490	Uprox	20	3-wire DC PNP	10-30 VDC	1500	≤200	-30 to +85	IP68	SS	WG	GN	YE	--	D 1	A2
NI20U-EM30-AN6X2-H1141/S1589 1646191	Uprox	20	3-wire DC NPN	10-30 VDC	1500	≤200	-30 to +85	IP68	SS	WG	GN	YE	--	D 2	A2
NI20U-MT30-AP6X2-H1141/S1589 1646291	Uprox, PTFE	20	3-wire DC PNP	10-30 VDC	1000	≤200	-30 to +85	IP67	TC	WG	GN	YE	--	D 1	A2
NI20-MT30-AN6X-H1141/S1589 4670589	PTFE	20	3-wire DC NPN	10-30 VDC	500	≤200	-25 to +70	IP67	TC	WG	N/A	YE	--	D 2	A2

"/S1589" = Weldguard coating added to sensor.

We reserve the right to make technical alterations without prior notice.

Weldguard

Weldguard | 30 mm

Embeddable Threaded Metal Barrels with Connector

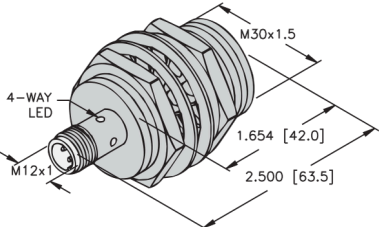
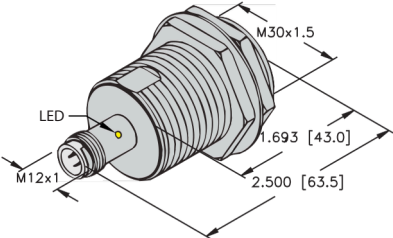
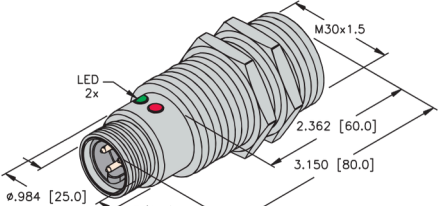
Housing Style	Dimension Drawings
	<p>A</p>  <p>30 mm - Embeddable, M12 Eurofast Connection, Stainless Steel</p>
<p>B</p>  <p>30 mm - Embeddable, M12 Eurofast Connection, Stainless Steel</p>	<p>C</p>  <p>30 mm - Embeddable, 7/8" Minifast Connection</p>

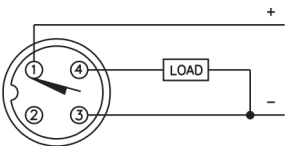
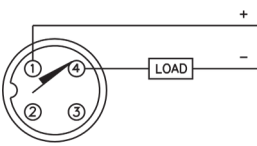
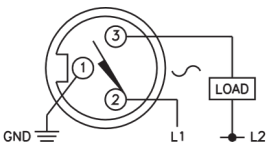
Wiring Diagrams/Mating Cordsets		
<p>1</p>  <p>Mating Cordset: RKV 4T-*</p>	<p>2</p>  <p>Mating Cordset: RK 4.23T-*</p>	<p>3</p>  <p>Mating Cordset: RKM 30-*M</p>

<p>A4</p> <p style="text-align: center;">2-wire AC/DC w/ Short-Circuit Protection - (ADZ, RDZ, FDZ, VDZ)</p> <p>Line Frequency: $\geq 50... \leq 60$ Hz</p> <p>Differential Travel (Hysteresis): 3-15% (5% typical)</p> <p>Voltage Drop Across Conducting Sensor: ≤ 6.0 V</p> <p>Trigger Current for Short Circuit Protection: AC: ≥ 440 mA; DC: ≥ 330 mA AC: ≥ 120 mA; DC: ≥ 120 mA</p> <p>Continuous Load Current: AC: ≤ 400 mA; DC: ≤ 300 mA AC: ≤ 100 mA; DC: ≤ 100 mA</p> <p>Off-State (leakage) Current: ≤ 1.7 mA (AC) ≤ 1.5 mA (DC)</p>	<p>Minimum Load Current: ≥ 3.0 mA</p> <p>Inrush Current: ≤ 3 A (≤ 20 ms, max 5 Hz)</p> <p>Power-On Effect: Per IEC 947-5-2</p> <p>Transient Protection: Per EN 60947-5-2</p> <p>Shock: 30 g, 11 ms</p> <p>Vibration: 55 Hz, 1 mm Amplitude, in all 3 Planes</p> <p>Repeatability: $\leq 2\%$ of Rated Operating Distance</p>
<p>A5</p> <p style="text-align: center;">2-wire DC Stainless Front Face (AG)</p> <p>Ripple: $\leq 10\%$</p> <p>Differential Travel (Hysteresis): 1-15% (5% typical)</p> <p>Voltage Drop Across Conducting Sensor: ≤ 3.5 V Polarized</p> <p>Trigger Current for Short Circuit Protection: ≥ 120 mA on 100 mA Load Current</p> <p>Minimum Load Current: ≥ 3.0 mA</p>	<p>Temperature Drift: $\leq \pm 20\%$</p> <p>Off-State (Leakage) Current: ≤ 0.8 mA</p> <p>Shock: 30 g, 11 ms</p> <p>Vibration: 55 Hz, 1 mm Amplitude in all 3 Planes</p> <p>Repeatability: $\leq 2\%$ of Rated Operating Distance</p>
<p>A7</p> <p style="text-align: center;">3-wire DC Stainless Front Face Ext Range (AP, AN, RP, RN)</p> <p>Ripple: $\leq 10\%$</p> <p>Differential Travel (Hysteresis): 20%</p> <p>Voltage Drop Across Conducting Sensor: ≤ 2 V</p> <p>Trigger Current for Short Circuit Protection: ≥ 220 mA on 200 mA Load Current</p> <p>No-Load Current: ≤ 10 mA</p> <p>Off-State (Leakage) Current: ≤ 0.1 mA</p>	<p>Temperature Drift: $\leq \pm 10\%$ Incorporated Incorporated 30</p> <p>Reverse Polarity Protection: g, 11 ms 55 Hz, 1 mm Amplitude, in all</p> <p>Wire-Break Protection: 3 Planes $\leq 5\%$ of Rated Operating</p> <p>Shock: Distance</p> <p>Vibration:</p> <p>Repeatability:</p>

We reserve the right to make technical alterations without prior notice.

Weldguard | 30 mm

Embeddable Threaded Metal Barrels with Connector

Part Number/ ID Number	Features	Sensing Range (mm)	Output	Voltage	Switching Freq. (Hz)	Operating Current (mA)	Operating Temp. (°C)	Protection	Housing	Front Cap/Face	Power LED	Output LED	Dimension Drawings	Wiring Diagrams	Spec List
BI20-EGT30F-AP6X-H1141/S1589 46147101	SSF, PTFE	20	3-wire DC PNP	10-30 VDC	100	≤200	-25 to +70	IP68/69K	TC	WG	N/A	YE	A	1	A7
BI10-EGT30F-AG6X-H1141/S1589 46146490	SSF, PTFE	10	2-wire DC	10-30 VDC	50	≤100	-25 to +70	IP68/69K	TC	WG	N/A	YE	B	2	A5
BI10- GT30-ADZ30X2-B1131/S34/S1589 4255280	PTFE, WFI	10	2-wire AC/DC Short-Circuit Protected	20-250 VAC/10- 300 VDC	20	≤400/300	-25 to +70	IP67	TC	WG	GN	RD	C	3	A4

"S1589" = Weldguard coating added to sensor.

We reserve the right to make technical alterations without prior notice.

Weldguard

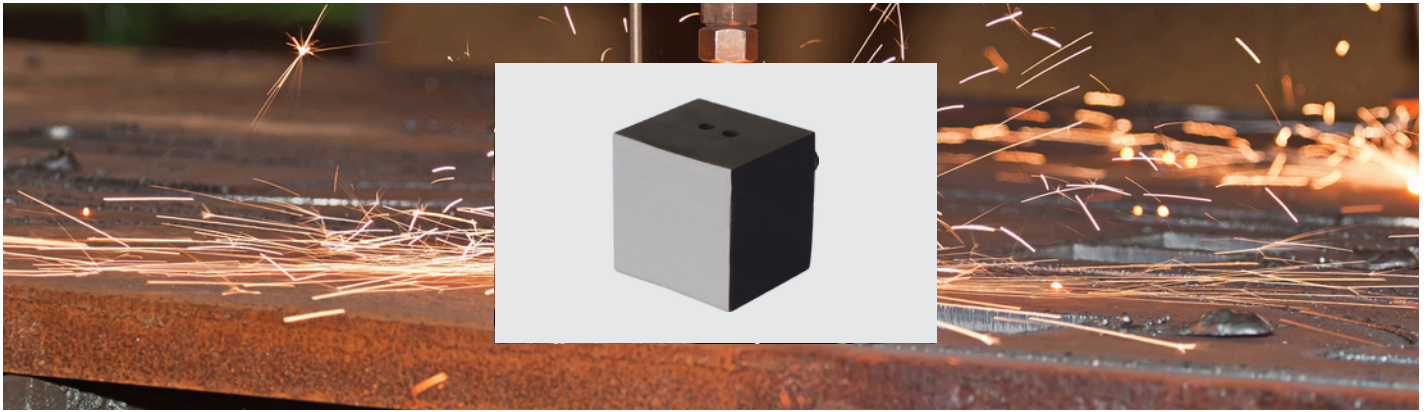

armor guard®

Turck's Armorguard provides built-in durability that:

- Protects the sensor face from impact
- Includes Weldguard material on the sensing face to resist weld slag
- Extends the life of the sensor exponentially
- Available in 8, 12, 18 or 30 mm barrel diameters, as well as cube style sensors

■ Protects against:







Armorguard Accessories:

- See Accessories section on page 109

We reserve the right to make technical alterations without prior notice.

Armorguard

	Rectangular	Embeddable/Nonembeddable Metal Barrel			
					
Housing	40 mm	8 mm	12 mm	18 mm	30 mm
Sensing Range	20 mm	2 mm	3 - 4 mm	5 - 8 mm	15 mm
Pages	52	54	54	56	56

Armorguard | CA40

Rotatable Sensing Head with Metal Housing

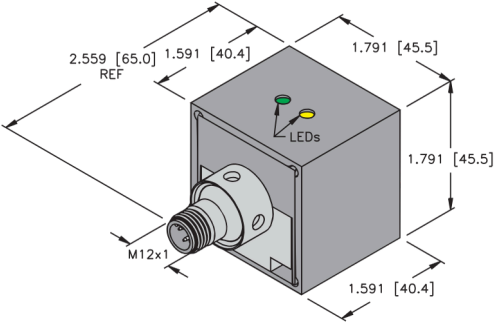
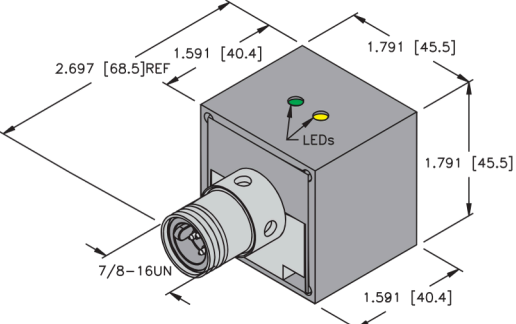
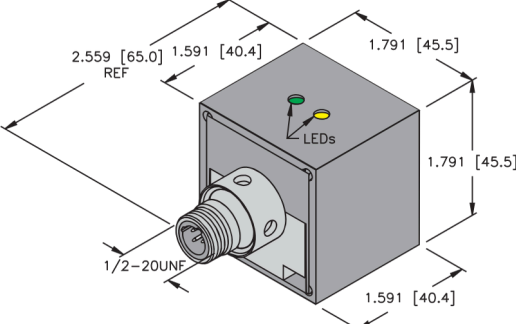
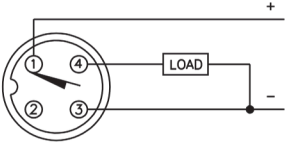
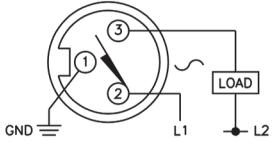
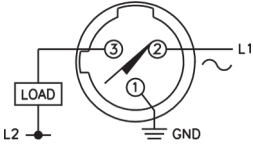
Housing Style	Dimension Drawings	
	<p>A</p>  <p>CA40 - Embeddable, Eurofast Connector</p>	
<p>B</p>  <p>CA40 - Embeddable, Minifast Connector</p>	<p>C</p>  <p>CA40 - Embeddable, Microfast Connector</p>	
Wiring Diagrams/Mating Cordsets		
<p>1</p>  <p>Mating Cordset: RK 4T-*</p>	<p>2</p>  <p>Mating Cordset: RKM 30-*M</p>	<p>3</p>  <p>Mating Cordset: KB 3T-*</p>
A2 3 and 4-wire DC - (AN, RN, AP, RP, VN, VP)		
<p>Ripple: $\leq 10\%$</p> <p>Differential Travel (Hysteresis): 3-15% (5% typical)</p> <p>Voltage Drop Across Conducting Sensor: $\leq 1.8\text{ V}$</p> <p>Trigger Current for Short Circuit Protection: $\geq 220\text{ mA}$ on 200 mA Load Current $\geq 170\text{ mA}$ on 150 mA Load Current $\geq 120\text{ mA}$ on 100 mA Load Current</p> <p>Off-State (Leakage) Current: $\leq 0.1\text{ mA}$</p> <p>No-Load Current: $\leq 15\text{ mA}$ (Ferrite, Uprox, Rectangular) $\leq 20\text{ mA}$ (Uprox+, Uprox 3)</p> <p>Time Delay Before Availability: $\leq 8\text{ ms}$</p>	<p>Power-On Effect: Per IEC 947-5-2 Incorporated</p> <p>Reverse Polarity Protection: Incorporated Per EN 60947-5-2</p> <p>Wire-Break Protection: $\leq \pm 10\%$ 30 g, 11 ms 55 Hz, 1 mm</p> <p>Transient Protection: Amplitude in all 3 Planes $\leq 2\%$ of Rated Operating Distance</p> <p>Temperature Drift: Rated Operating Distance</p> <p>Shock:</p> <p>Vibration:</p> <p>Repeatability:</p>	
A3 2-wire DC - (AD, RD, AG)		
<p>Ripple: $\leq 10\%$</p> <p>Differential Travel (Hysteresis): 3-15% (5% typical)</p> <p>Voltage Drop Across Conducting Sensor: Non-polarized (AD) $< 5.0\text{ V}$ Polarized (AG) $\leq 4.2\text{ V}$</p> <p>Trigger Current for Short Circuit Protection: $\geq 120\text{ mA}$</p> <p>Minimum Load Current: $\geq 3.0\text{ mA}$</p>	<p>Off-State (Leakage) Current: $\leq 0.8\text{ mA}$</p> <p>Power-On Effect: Per IEC 947-5-2</p> <p>Transient Protection: Per EN 60947-5-2</p> <p>Shock: 30 g, 11 ms</p> <p>Vibration: 55 Hz, 1 mm Amplitude in all 3 Planes</p> <p>Repeatability: $\leq 2\%$ of Rated Operating Distance</p>	

We reserve the right to make technical alterations without prior notice.

Armorguard | CA40

Rotatable Sensing Head with Metal Housing

Part Number/ ID Number	Features	Sensing Range (mm)	Output	Voltage	Switching Freq. (Hz)	Operating Current (mA)	Operating Temp. (°C)	Protection	Housing	Front Cap/Face	Power LED	Output LED	Dimension Drawings	Wiring Diagrams	Spec List
BI20U-CA40-AP6X2-H1141/S1591W/BS2.1 1627294	Uprox	20	3-wire DC PNP	10-30 VDC	250	≤200	0 to +70	IP67	AL	WG	GN	YE	A	1	A2
BI20U-CA40-AP6X2-H1141/S1591W/BS2.0 1627296	Uprox	20	3-wire DC PNP	10-30 VDC	250	≤200	0 to +70	IP67	AL	WG	GN	YE	A	1	A2
BI20-CA40-ADZ30X2-B1131/S34/S1591 W/BS21 4283595	WFI	20	2-wire AC/DC Short-Circuit Protected	20-250 VAC/10-300 VDC	300	≤400/300	-25 to +70	IP67	AL	WG	GN	YE	B	2	A3
BI20-CA40-ADZ30X2-B3131/S34/S1591 W/BS21 4283596	WFI	20	2-wire AC/DC Short-Circuit Protected	20-250 VAC/10-300 VDC	300	≤400/300	-25 to +70	IP67	AL	WG	GN	YE	C	3	A3

"/S1591" = Sensor encased in tool steel sleeve with Weldguard coating on face.

We reserve the right to make technical alterations without prior notice.

BS 2.1 Mounting Bracket

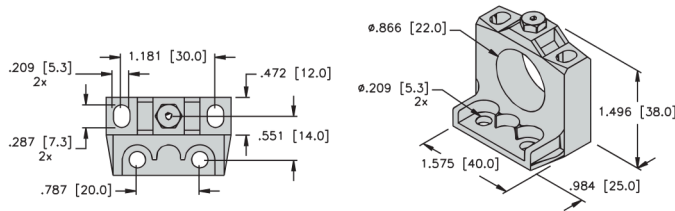

BS 2.0 Mounting Bracket

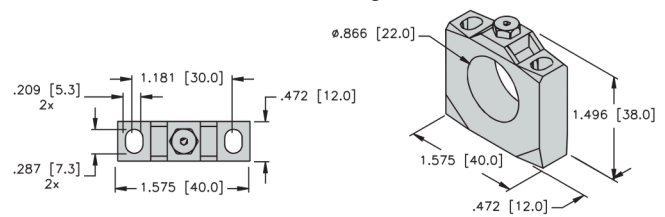

Armorguard

Armorguard | 8 mm, 12 mm

Embeddable Threaded Metal Barrels with DC Outputs

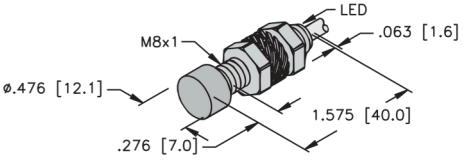
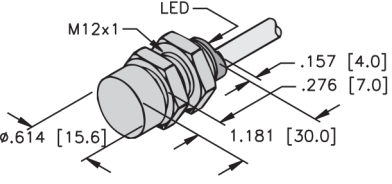
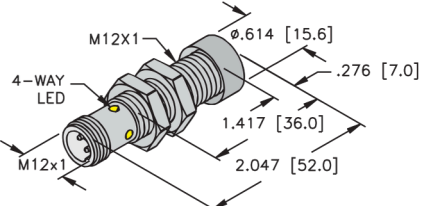
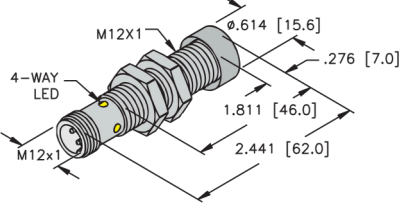
Housing Style	Dimension Drawings
	<p>A</p>  <p>8 mm - Embeddable, Miniature Threaded Barrel, Potted-In Cable</p>
<p>B</p>  <p>12 mm - Embeddable, Potted-in Cable</p>	<p>C</p>  <p>12 mm - Embeddable, M12 Eurofast Connection</p>
<p>D</p>  <p>12 mm - Embeddable, M12 Eurofast Connection, Extended Barrel Length</p>	

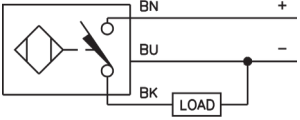
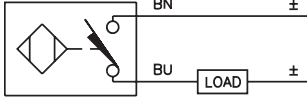
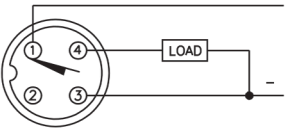
Wiring Diagrams/Mating Cordsets		
<p>1</p> 	<p>2</p> 	<p>3</p>  <p>Mating Cordset: RK 4T-*</p>

A2 3 and 4-wire DC - (AN, RN, AP, RP, VN, VP)	
<p>Ripple: ≤10%</p> <p>Differential Travel (Hysteresis): 3-15% (5% typical)</p> <p>Voltage Drop Across Conducting Sensor: ≤1.8 V</p> <p>Trigger Current for Short Circuit Protection: ≥220 mA on 200 mA Load Current ≥170 mA on 150 mA Load Current ≥120 mA on 100 mA Load Current</p> <p>Off-State (Leakage) Current: ≤0.1 mA</p> <p>No-Load Current: ≤15 mA (Ferrite, Uprox, Rectangular) ≤20 mA (Uprox+, Uprox 3)</p> <p>Time Delay Before Availability: ≤8 ms</p>	<p>Power-On Effect: Per IEC 947-5-2 Incorporated</p> <p>Reverse Polarity Protection: Incorporated Per EN 60947-5-2</p> <p>Wire-Break Protection: ≤±10% 30 g, 11 ms 55 Hz, 1 mm</p> <p>Transient Protection: Amplitude in all 3 Planes ≤2% of Rated Operating Distance</p> <p>Temperature Drift: Rated Operating Distance</p> <p>Shock:</p> <p>Vibration:</p> <p>Repeatability:</p>
A3 2-wire DC - (AD, RD, AG)	
<p>Ripple: ≤10%</p> <p>Differential Travel (Hysteresis): 3-15% (5% typical)</p> <p>Voltage Drop Across Conducting Sensor: Non-polarized (AD) <5.0 V Polarized (AG) ≤4.2 V</p> <p>Trigger Current for Short Circuit Protection: ≥120 mA</p> <p>Minimum Load Current: ≥3.0 mA</p>	<p>Off-State (Leakage) Current: ≤0.8 mA</p> <p>Power-On Effect: Per IEC 947-5-2</p> <p>Transient Protection: Per EN 60947-5-2</p> <p>Shock: 30 g, 11 ms</p> <p>Vibration: 55 Hz, 1 mm Amplitude in all 3 Planes</p> <p>Repeatability: ≤2% of Rated Operating Distance</p>

We reserve the right to make technical alterations without prior notice.

Armorguard | 8 mm, 12 mm

Embeddable Threaded Metal Barrels with DC Outputs

Part Number/ ID Number	Features	Sensing Range (mm)	Output	Voltage	Switching Freq. (Hz)	Operating Current (mA)	Operating Temp. (°C)	Protection	Housing	Front Cap/Face	Power LED	Output LED	Dimension Drawings	Wiring Diagrams	Spec List
BI2-EG08-AP6X/S1610 46020861		2	3-wire DC PNP	10-30 VDC	3000	≤150	-25 to +70	IP67	SS	WG	N/A	YE	A	1	A2
BI3-GT12K-AD4X/S1610 44050832	PTFE	3	2-wire DC	10-65 VDC	1000	≤100	-25 to +70	IP67	TC	WG	N/A	YE	B	2	A3
BI4U-MT12-AP6X-H1141/S1610 16348092	Uprox+, PTFE	4	3-wire DC PNP	10-30 VDC	2000	≤200	-30 to +85	IP68	TC	WG	N/A	YE	C	3	A2
BI3U-MT12E-AP6X2-H1141/S1610 1634292	Uprox, PTFE	3	3-wire DC PNP	10-30 VDC	2000	≤200	-30 to +85	IP67	TC	WG	GN	YE	D	3	A2

"/S1610" = Sensor with 7 mm tool steel ring threaded onto the barrel, with Weldguard coating on sensing face.

We reserve the right to make technical alterations without prior notice.

Armorguard

Armorguard | 18 mm, 30 mm

Embeddable Threaded Metal Barrels with Connector and DC Outputs

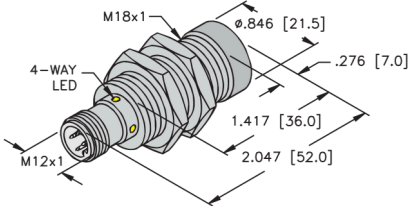
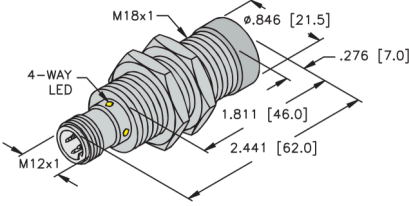
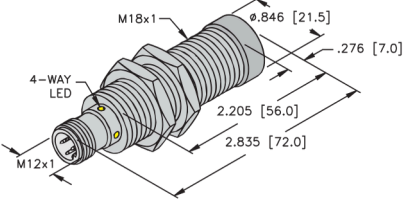
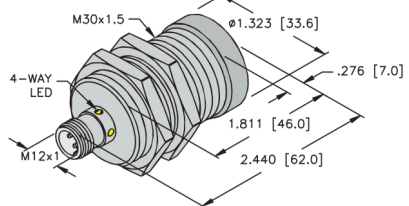
Housing Style	Dimension Drawings
	<p>A</p>  <p>18 mm - Embeddable, M12 Eurofast Connection</p>
<p>B</p>  <p>18 mm - Embeddable, M12 Eurofast Connection</p>	<p>C</p>  <p>18 mm - Embeddable, Ext. Barrel Length, M12 Eurofast Connection</p>
<p>D</p>  <p>30 mm - Embeddable, M12 Eurofast Connection</p>	

Wiring Diagrams/Mating Cordsets



A2 3 and 4-wire DC - (AN, RN, AP, RP, VN, VP)

<p>Ripple: $\leq 10\%$</p> <p>Differential Travel (Hysteresis): 3-15% (5% typical)</p> <p>Voltage Drop Across Conducting Sensor: $\leq 1.8\text{ V}$</p> <p>Trigger Current for Short Circuit Protection: $\geq 220\text{ mA}$ on 200 mA Load Current $\geq 170\text{ mA}$ on 150 mA Load Current $\geq 120\text{ mA}$ on 100 mA Load Current</p> <p>Off-State (Leakage) Current: $\leq 0.1\text{ mA}$</p> <p>No-Load Current: $\leq 15\text{ mA}$ (Ferrite, Uprox, Rectangular) $\leq 20\text{ mA}$ (Uprox+, Uprox 3)</p> <p>Time Delay Before Availability: $\leq 8\text{ ms}$</p>	<p>Power-On Effect: Per IEC 947-5-2 Incorporated</p> <p>Reverse Polarity Protection: Incorporated Per EN 60947-5-2</p> <p>Wire-Break Protection: $\leq \pm 10\%$ 30 g, 11 ms 55 Hz, 1 mm</p> <p>Transient Protection: Amplitude in all 3 Planes $\leq 2\%$ of Rated Operating Distance</p> <p>Temperature Drift: Rated Operating Distance</p> <p>Shock:</p> <p>Vibration:</p> <p>Repeatability:</p>
--	---

We reserve the right to make technical alterations without prior notice.

Armorguard | 18 mm, 30 mm

Embeddable Threaded Metal Barrels with Connector and DC Outputs

Part Number/ ID Number	Features	Sensing Range (mm)	Output	Voltage	Switching Freq. (Hz)	Operating Current (mA)	Operating Temp. (°C)	Protection	Housing	Front Cap/Face	Power LED	Output LED	Dimension Drawings	Wiring Diagrams	Spec List
BI8U-MT18-AP6X-H1141/S1610 16447302	Uprox+, PTFE	8	3-wire DC PNP	10-30 VDC	1500	≤200	-30 to +85	IP68	TC	WG	N/A	YE	B	1	A2
BI8U-MT18M-AP6X2-H1141/S1610 1644788	Uprox+, PTFE	8	3-wire DC PNP	10-30 VDC	1500	≤200	-30 to +85	IP68	TC	WG	GN	YE	A	1	A2
BI8-EM18E-AP6X-H1141/S1610 46150954		8	3-wire DC PNP	10-30 VDC	500	≤200	-25 to +70	IP67	SS	WG	N/A	YE	C	1	A2
BI5U-EM18-AP6X2-H1141/S395/S1610 1635198	Uprox	5	3-wire DC PNP	10-30 VDC	2500	≤200	-30 to +85	IP67	SS	WG	N/A	YE	B	1	A2
BI5U-MT18-AP6X2-H1141/S395/S1610 1635293	Uprox, PTFE	5	3-wire DC PNP	10-30 VDC	1500	≤200	-30 to +85	IP67	TC	WG	GN	YE	B	1	A2
BI15-EM30-AP6X-H1141/S1610 4618589		15	3-wire DC PNP	10-30 VDC	300	≤200	-25 to +70	IP67	SS	WG	N/A	YE	D	1	A2

"/S1610" = Sensor with 7 mm tool steel ring threaded onto the barrel, with Weldguard coating on sensing face.

We reserve the right to make technical alterations without prior notice.



Armorguard



Stainless Steel Front Face

Turck's heavy-duty stainless steel construction:

- Protects the barrels and internal electronics from damage due to impact
- Protects the sensing face from damage due to abrasion
- Is available with PTFE or Weldguard coating for protection against weld slag
- Prevents oils and lubricants from seeping into the sensor
- Utilizes one-piece stainless steel housing
- Is offered in standard and extended sensing ranges

■ Protects against:



We reserve the right to make technical alterations without prior notice.

Stainless Steel Front Face

	Rectangular	Stainless Steel Front Face Barrel			
Housing	8 mm	8 mm	12 mm	18 mm	30 mm
Sensing Range	7 mm	1.5 - 3 mm	2 - 6 mm	5 - 10 mm	10 - 20 mm
Pages	64	60, 64	60, 66	62, 68	62, 68

Stainless Steel Front Face | 8 mm, 12 mm

Embeddable Threaded Metal Barrels with 2-Wire DC Outputs

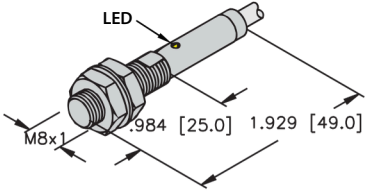
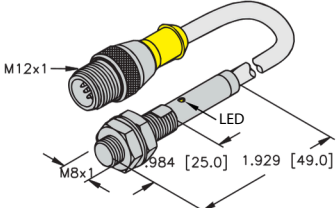
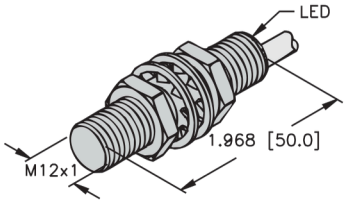
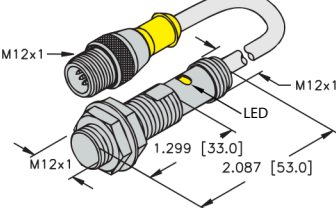
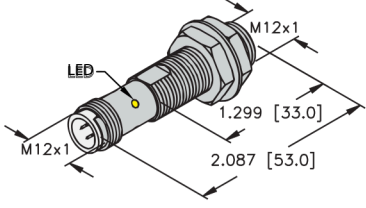
Housing Style	Dimension Drawings
	<p>A</p>  <p>8 mm - Embeddable, Stainless Steel Barrel, Potted-In Cable</p>
<p>B</p>  <p>8 mm - Embeddable, Stainless Steel Barrel, M12 Eurofast Quick Disconnect</p>	<p>C</p>  <p>12 mm - Embeddable, Stainless Steel Barrel, Potted-In Cable</p>
<p>D</p>  <p>12 mm - Embeddable, Stainless Steel Barrel, M12 Eurofast Quick Disconnect</p>	<p>E</p>  <p>12 mm - Embeddable, Stainless Steel Barrel, M12 Eurofast Connection</p>

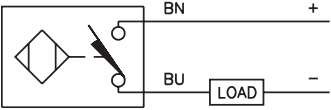
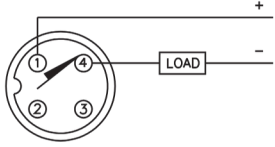
Wiring Diagrams/Mating Cordsets	
<p>1</p> 	<p>2</p>  <p>Mating Cordset: RKV 4.23T-*</p>

A5 2-wire DC Stainless Front Face (AG)	
<ul style="list-style-type: none"> Ripple: $\leq 10\%$ Differential Travel (Hysteresis): 1-15% (5% typical) Voltage Drop Across Conducting Sensor: ≤ 3.5 V Polarized Trigger Current for Short Circuit Protection: ≥ 120 mA on 100 mA Load Current Minimum Load Current: ≥ 3.0 mA 	<ul style="list-style-type: none"> Temperature Drift: $\leq \pm 20\%$ Off-State (Leakage) Current: ≤ 0.8 mA Shock: 30 g, 11 ms Vibration: 55 Hz, 1 mm Amplitude in all 3 Planes Repeatability: $\leq 2\%$ of Rated Operating Distance

We reserve the right to make technical alterations without prior notice.

Stainless Steel Front Face | 8 mm, 12 mm

Embeddable Threaded Metal Barrels with 2-Wire DC Outputs

Part Number/ ID Number	Features	Sensing Range (mm)	Output	Voltage	Switching Freq. (Hz)	Operating Current (mA)	Operating Temp. (°C)	Protection	Housing	Face	Power LED	Output LED	Cable Length/Jacket	Wiring Diagrams Dimension Drawings	Spec List	
Bi1.5-EG08F-AG6X 4614628	SSF	1.5	2-wire DC	10-30 VDC	200	≤100	-25 to +70	IP68/69K	SS	SS	GN	RD	2M/PVC	A	1	A5
Bi1.5-EGT08F-AG6X 4614677	SSF, PTFE	1.5	2-wire DC	10-30 VDC	200	≤100	-25 to +70	IP68/69K	TC	SS	GN	RD	2M/PVC	A	1	A5
Bi1.5-EG08F-AG6X-0.3-RS4.23T 4614684	SSF	1.5	2-wire DC	10-30 VDC	200	≤100	-25 to +70	IP68/69K	SS	SS	GN	RD	0.3M/PVC	B	2	A5
Bi1.5-EGT08F-AG6X-0.2-RS4.23T 4614686	SSF, PTFE	1.5	2-wire DC	10-30 VDC	200	≤100	-25 to +70	IP68/69K	TC	SS	GN	RD	0.2M/PVC	B	2	A5
Bi2-EG08F-AG6X 4614664	SSF	2	2-wire DC	10-30 VDC	200	≤100	-25 to +70	IP67	SS	SS	N/A	RD	2M/PVC	A	1	A5
Bi2-EG12F-AG6X 4614634	SSF	2	2-wire DC	10-30 VDC	100	≤100	-25 to +70	IP68/69K	SS	SS	GN	RD	2M/PVC	C	1	A5
Bi2-EGT12F-AG6X 46146651	SSF, PTFE	2	2-wire DC	10-30 VDC	100	≤100	-25 to +70	IP68/69K	TC	SS	GN	RD	2M/PVC	C	1	A5
Bi3-EG12F-AG6X 4614665	SSF	2	2-wire DC	10-30 VDC	100	≤100	-25 to +70	IP68/69K	SS	SS	GN	RD	0.3M/PVC	D	2	A5
Bi2-EG12F-AG6X-H1141 4614637	SSF	3	2-wire DC	10-30 VDC	80	≤100	-25 to +70	IP67	SS	SS	N/A	RD	2M/PVC	C	1	A5
	SSF	2	2-wire DC	10-30 VDC	100	≤100	-25 to +70	IP68/69K	SS	SS	GN	RD	--	E	2	A5
Bi2-EGT12F-AG6X-H1141 4614698	SSF, PTFE	2	2-wire DC	10-30 VDC	100	≤100	-25 to +70	IP68/69K	TC	SS	GN	RD	--	E	2	A5

We reserve the right to make technical alterations without prior notice.

Stainless Steel Front Face

Stainless Steel Front Face | 18 mm, 30 mm

Embeddable Threaded Metal Barrels with 2-Wire DC Outputs

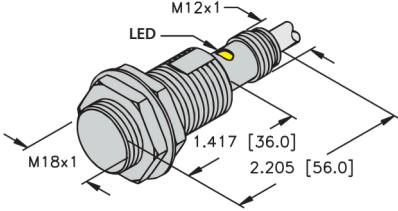
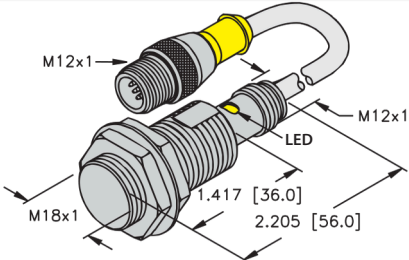
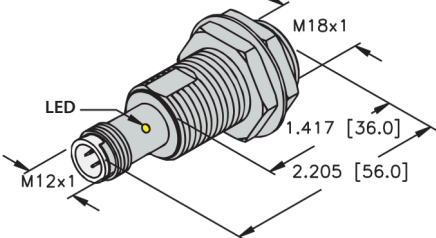
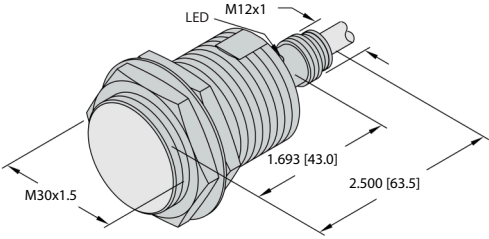
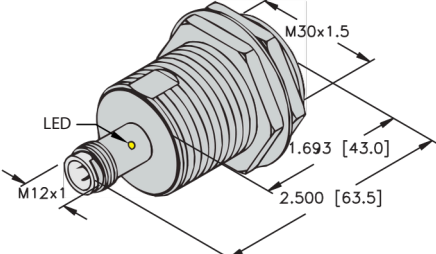
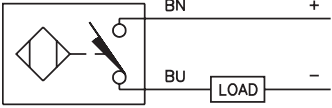
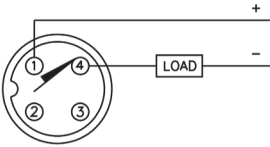
Housing Style	Dimension Drawings
	<p>A</p>  <p>18 mm - Embeddable, Stainless Steel Barrel, Potted-In Cable</p>
<p>B</p>  <p>18 mm - Embeddable, Stainless Steel Barrel, M12 Eurofast Quick Disconnect</p>	<p>C</p>  <p>18 mm - Embeddable, Stainless Steel Barrel, M12 Eurofast Connection</p>
<p>D</p>  <p>30 mm - Embeddable, Stainless Steel Barrel, Potted-In Cable</p>	<p>E</p>  <p>30 mm - Embeddable, M12 Eurofast Connection, Stainless Steel</p>
Wiring Diagrams/Mating Cordsets	
<p>1</p> 	<p>2</p>  <p>Mating Cordset: RKV 4T-*; RKV 4.23T-*</p>
A5 2-wire DC Stainless Front Face (AG)	
<p>Ripple: $\leq 10\%$</p> <p>Differential Travel (Hysteresis): 1-15% (5% typical)</p> <p>Voltage Drop Across Conducting Sensor: ≤ 3.5 V Polarized</p> <p>Trigger Current for Short Circuit Protection: ≥ 120 mA on 100 mA Load Current</p> <p>Minimum Load Current: ≥ 3.0 mA</p>	<p>Temperature Drift: $\leq \pm 20\%$</p> <p>Off-State (Leakage) Current: ≤ 0.8 mA</p> <p>Shock: 30 g, 11 ms</p> <p>Vibration: 55 Hz, 1 mm Amplitude in all 3 Planes</p> <p>Repeatability: $\leq 2\%$ of Rated Operating Distance</p>

We reserve the right to make technical alterations without prior notice.

Stainless Steel Front Face | 18 mm, 30 mm

Embeddable Threaded Metal Barrels with 2-Wire DC Outputs

Part Number/ ID Number	Features	Sensing Range (mm)	Output	Voltage	Switching Freq. (Hz)	Operating Current (mA)	Operating Temp. (°C)	Protection	Housing	Face	Power LED	Output LED	Cable Length/Jacket	Wiring Diagrams Dimension Drawings	Spec List	
Bi5-EG18F-AG6X 4614640	SSF	5	2-wire DC	10-30 VDC	100	≤100	-25 to +70	IP68/69K	SS	SS	GN	RD	2M/PVC	A	1	A5
Bi5-EGT18F-AG6X 46146400	SSF, PTFE	5	2-wire DC	10-30 VDC	100	≤100	-25 to +70	IP68/69K	TC	SS	GN	RD	2M/PVC	A	1	A5
Bi5-EG18F-AG6X-0.3-RS4.23T 4614694	SSF	5	2-wire DC	10-30 VDC	100	≤100	-25 to +70	IP68/69K	SS	SS	GN	RD	0.3M/PVC	B	2	A5
Bi7-EG18F-AG6X 4614666	SSF	7	2-wire DC	10-30 VDC	100	≤100	-25 to +70	IP67	SS	SS	N/A	RD	2M/PVC	A	1	A5
Bi5-EG18F-AG6X-H1141 4614643	SSF	5	2-wire DC	10-30 VDC	100	≤100	-25 to +70	IP68/69K	SS	SS	GN	RD	--	C	2	A5
Bi12-EG30F-AG6X 4614667	SSF	12	2-wire DC	10-30 VDC	50	≤100	-25 to +70	IP67	SS	SS	N/A	RD	2M/PVC	D	1	A5
Bi10-EG30F-AG6X-H1141 4614649	SSF	10	2-wire DC	10-30 VDC	50	≤100	-25 to +70	IP68/69K	SS	SS	GN	RD	--	E	2	A5

We reserve the right to make technical alterations without prior notice.

Stainless Steel Front Face

Stainless Steel Front Face | 8 mm

Embeddable Rectangular and Threaded Metal Barrels with 3-Wire DC Outputs

Housing Style	Dimension Drawings	
	<p>A</p> <p>8 mm - Embeddable, Stainless Steel, Potted-In Cable</p>	<p>B</p> <p>8 mm - Embeddable, Stainless Steel, M12 Eurofast Quick Disconnect</p>

We reserve the right to make technical alterations without prior notice.

Wiring Diagrams/Mating Cordsets			
		Mating Cordset: RKV 4T-*	Mating Cordset: RKV 4T-*

A6	3-wire DC Stainless Front Face (AP, AN, RP, RN)	
<ul style="list-style-type: none"> Ripple: $\leq 10\%$ Differential Travel (Hysteresis): 3-15% (5% typical) Voltage Drop Across Conducting Sensor: $\leq 1.8\text{ V}$ Trigger Current for Short Circuit Protection: $\geq 220\text{ mA}$ on 200 mA Load Current No-Load Current: $\leq 15\text{ mA}$ Off-State (Leakage) Current: $\leq 0.1\text{ mA}$ 	<ul style="list-style-type: none"> Temperature Drift: $\leq \pm 10\%$ Incorporated Incorporated 30 g, 11 ms 55 Hz, 1 mm Amplitude in all Reverse Polarity Protection: 3 Planes $\leq 2\%$ of Rated Operating Distance Wire-Break Protection: Shock: Distance Vibration: Repeatability: 	
A7	3-wire DC Stainless Front Face Ext Range (AP, AN, RP, RN)	
<ul style="list-style-type: none"> Ripple: $\leq 10\%$ Differential Travel (Hysteresis): 20% Voltage Drop Across Conducting Sensor: $\leq 2\text{ V}$ Trigger Current for Short Circuit Protection: $\geq 220\text{ mA}$ on 200 mA Load Current No-Load Current: $\leq 10\text{ mA}$ Off-State (Leakage) Current: $\leq 0.1\text{ mA}$ 	<ul style="list-style-type: none"> Temperature Drift: $\leq \pm 10\%$ Incorporated Incorporated 30 g, 11 ms 55 Hz, 1 mm Amplitude, in all Reverse Polarity Protection: 3 Planes $\leq 5\%$ of Rated Operating Distance Wire-Break Protection: Shock: Distance Vibration: Repeatability: 	

Stainless Steel Front Face | 8 mm

Embeddable Rectangular and Threaded Metal Barrels with 3-Wire DC Outputs

Part Number/ ID Number	Features	Sensing Range (mm)	Output	Voltage	Switching Freq. (Hz)	Operating Current (mA)	Operating Temp. (°C)	Protection	Housing	Face	Power LED	Output LED	Cable Length/Jacket	Wiring Diagrams Dimension Drawings	Spec List	
Bi7-Q08F-AN6X 1608914	SSF	7	3-wire DC NPN	10-30 VDC	200	≤200	-25 to +70	IP68/69K	SS	SS	N/A	YE	2M/TPU	A	2	A7
Bi7-Q08F-AP6X 1608916	SSF	7	3-wire DC PNP	10-30 VDC	200	≤200	-25 to +70	IP68/69K	SS	SS	N/A	YE	2M/TPU	A	1	A7
Bi7-Q08F-AP6X-0.2-RS4T 16089160	SSF	7	3-wire DC PNP	10-30 VDC	200	≤200	-25 to +70	IP68/69K	SS	SS	N/A	YE	0.2M/TPU	B	3	A7
Bi1.5-EG08F-AN6X 4614627	SSF	1.5	3-wire DC NPN	10-30 VDC	200	≤200	-25 to +70	IP68/69K	SS	SS	N/A	YE	2M/PVC	C	2	A6
Bi3-EG08FE-AN6X 4614712	SSF	3	3-wire DC NPN	10-30 VDC	1000	≤200	-25 to +70	IP67	SS	SS	N/A	YE	2M/TPU	D	2	A7
Bi1.5-EG08F-AP6X 4614626	SSF	1.5	3-wire DC PNP	10-30 VDC	200	≤200	-25 to +70	IP68/69K	SS	SS	N/A	YE	2M/PVC	C	1	A6
Bi3-EG08FE-AP6X 4614704	SSF, PTFE	1.5	3-wire DC PNP	10-30 VDC	200	≤200	-25 to +70	IP68/69K	TC	SS	N/A	YE	2M/PVC	C	1	A6
Bi3-EGT08FE-AP6X 46147043	SSF	3	3-wire DC PNP	10-30 VDC	1000	≤200	-25 to +70	IP67	SS	SS	N/A	YE	2M/TPU	D	1	A7
Bi1.5-EG08F-AN6X-H1341 4614630	SSF, PTFE	3	3-wire DC PNP	10-30 VDC	1000	≤200	-25 to +70	IP67	TC	SS	N/A	YE	2M/TPU	D	1	A7
	SSF	1.5	3-wire DC NPN	10-30 VDC	200	≤200	-25 to +70	IP68/69K	SS	SS	N/A	YE	--	E	4	A6
Bi3-EG08FE-AN6X-H1341 4614711	SSF	3	3-wire DC NPN	10-30 VDC	1000	≤200	-25 to +70	IP67	SS	SS	N/A	YE	--	F	4	A7
Bi1.5-EG08F-AP6X-H1341 4614629	SSF	1.5	3-wire DC PNP	10-30 VDC	200	≤200	-25 to +70	IP68/69K	SS	SS	N/A	YE	--	E	3	A6
Bi3-EG08FE-AP6X-H1341 4614703	SSF	3	3-wire DC PNP	10-30 VDC	1000	≤200	-25 to +70	IP67	SS	SS	N/A	YE	--	F	3	A7
Bi3-EGT08FE-AP6X-H1341 46147030	SSF,PTFE	3	3-wire DC PNP	10-30 VDC	1000	≤200	-25 to +70	IP67	TC	SS	N/A	YE	--	F	3	A7

We reserve the right to make technical alterations without prior notice.

Stainless Steel Front Face

Stainless Steel Front Face | 12 mm

Embeddable Threaded Metal Barrels with 3-Wire DC Outputs

Housing Style	Dimension Drawings
	<p>A</p> <p>12 mm - Embeddable, Stainless Steel Barrel, Potted-In Cable</p>
<p>B</p> <p>12 mm - Embeddable, Stainless Steel Barrel, Potted-In Cable</p>	<p>C</p> <p>12 mm - Embeddable, Stainless Steel Barrel, M12 Eurofast Connection</p>
<p>D</p> <p>12 mm - Embeddable, Stainless Steel Barrel, M12 Eurofast Connection</p>	

Wiring Diagrams/Mating Cordsets			
<p>1</p>	<p>2</p>	<p>3</p> <p>Mating Cordset: RKV 4T-*</p>	<p>4</p> <p>Mating Cordset: RKV 4T-*</p>

A6 3-wire DC Stainless Front Face (AP, AN, RP, RN)	
<ul style="list-style-type: none"> Ripple: $\leq 10\%$ Differential Travel (Hysteresis): 3-15% (5% typical) Voltage Drop Across Conducting Sensor: $\leq 1.8\text{ V}$ Trigger Current for Short Circuit Protection: $\geq 220\text{ mA}$ on 200 mA Load Current No-Load Current: $\leq 15\text{ mA}$ Off-State (Leakage) Current: $\leq 0.1\text{ mA}$ 	<ul style="list-style-type: none"> Temperature Drift: $\leq \pm 10\%$ Incorporated Incorporated 30 Reverse Polarity Protection: g, 11 ms 55 Hz, 1 mm Amplitude in all Wire-Break Protection: 3 Planes $\leq 2\%$ of Rated Operating Shock: Distance Vibration: Repeatability:
A7 3-wire DC Stainless Front Face Ext Range (AP, AN, RP, RN)	
<ul style="list-style-type: none"> Ripple: $\leq 10\%$ Differential Travel (Hysteresis): 20% Voltage Drop Across Conducting Sensor: $\leq 2\text{ V}$ Trigger Current for Short Circuit Protection: $\geq 220\text{ mA}$ on 200 mA Load Current No-Load Current: $\leq 10\text{ mA}$ Off-State (Leakage) Current: $\leq 0.1\text{ mA}$ 	<ul style="list-style-type: none"> Temperature Drift: $\leq \pm 10\%$ Incorporated Incorporated 30 Reverse Polarity Protection: g, 11 ms 55 Hz, 1 mm Amplitude, in all Wire-Break Protection: 3 Planes $\leq 5\%$ of Rated Operating Shock: Distance Vibration: Repeatability:

We reserve the right to make technical alterations without prior notice.

Stainless Steel Front Face | 12 mm

Embeddable Threaded Metal Barrels with 3-Wire DC Outputs

Part Number/ ID Number	Features	Sensing Range (mm)	Output	Voltage	Switching Freq. (Hz)	Operating Current (mA)	Operating Temp. (°C)	Protection	Housing	Face	Power LED	Output LED	Cable Length/Jacket	Wiring Diagrams Dimension Drawings	Spec List	
Bi2-EG12F-AN6X 4614633	SSF	2	3-wire DC NPN	10-30 VDC	100	≤200	-25 to +70	IP68/69K	SS	SS	N/A	YE	2M/TPU	A	2	A6
Bi6-EG12FE-AN6X 4614721	SSF	6	3-wire DC NPN	10-30 VDC	600	≤200	-25 to +70	IP68/69K	SS	SS	N/A	YE	2M/TPU	B	2	A7
Bi2-EG12F-AP6X 4614632	SSF	2	3-wire DC PNP	10-30 VDC	100	≤200	-25 to +70	IP68/69K	SS	SS	N/A	YE	0.2M/TPU	A	1	A6
Bi6-EG12FE-AP6X 4614720	SSF	6	3-wire DC PNP	10-30 VDC	600	≤200	-25 to +70	IP68/69K	SS	SS	N/A	YE	2M/PVC	B	1	A7
Bi2-EG12F-AN6X-H1141 4614636	SSF	2	3-wire DC NPN	10-30 VDC	100	≤200	-25 to +70	IP68/69K	SS	SS	N/A	YE	2M/TPU	C	4	A6
Bi6-EG12FE-AN6X-H1141 4614714	SSF	6	3-wire DC NPN	10-30 VDC	600	≤200	-25 to +70	IP68/69K	SS	SS	N/A	YE	2M/PVC	D	4	A7
Bi6-EGT12FE-AN6X-H1141 46147140	SSF	6	3-wire DC NPN	10-30 VDC	600	≤200	-25 to +70	IP68/69K	SS	SS	N/A	YE	2M/PVC	D	4	A7
Bi2-EG12F-AP6X-H1141 4614635	SSF, PTFE	6	3-wire DC NPN	10-30 VDC	600	≤200	-25 to +70	IP68/69K	TC	SS	N/A	YE	2M/PVC	D	4	A7
Bi2-EGT12F-AP6X-H1141 46146971	SSF	2	3-wire DC PNP	10-30 VDC	100	≤200	-25 to +70	IP68/69K	SS	SS	N/A	YE	2M/TPU	C	3	A6
Bi6-EG12FE-AP6X-H1141 4614706	SSF, PTFE	2	3-wire DC PNP	10-30 VDC	100	≤200	-25 to +70	IP68/69K	TC	SS	N/A	YE	2M/TPU	C	3	A6
	SSF	6	3-wire DC PNP	10-30 VDC	600	≤200	-25 to +70	IP68/69K	SS	SS	N/A	YE	--	D	3	A7
Bi6-EGT12FE-AP6X-H1141 46147060	SSF, PTFE	6	3-wire DC PNP	10-30 VDC	600	≤200	-25 to +70	IP68/69K	TC	SS	N/A	YE	--	D	3	A7

We reserve the right to make technical alterations without prior notice.

Stainless Steel Front Face

Stainless Steel Front Face | 18 mm, 30 mm

Embeddable Threaded Metal Barrels with 3-Wire DC Outputs

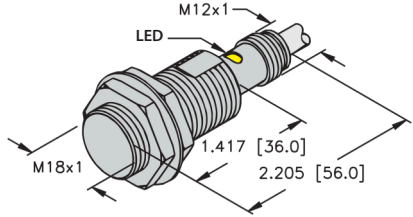
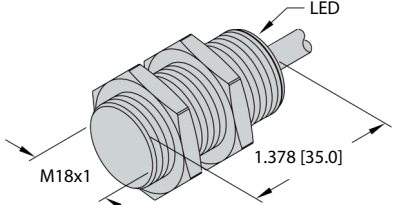
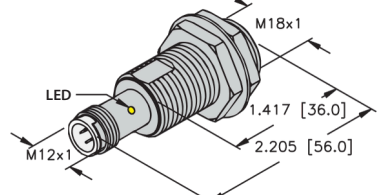
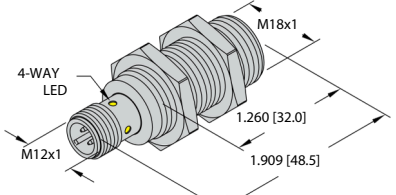
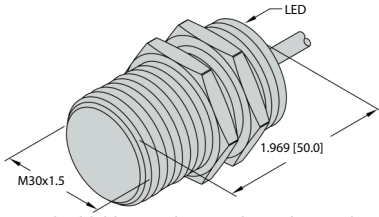
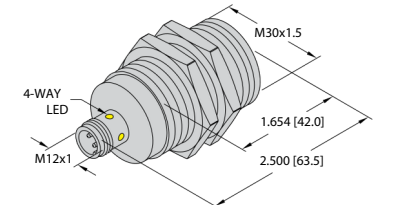
Housing Style	Dimension Drawings
	<p>A</p>  <p>18 mm - Embeddable, Stainless Steel Barrel, Potted-In Cable</p>
<p>B</p>  <p>18 mm - Embeddable, Stainless Steel Barrel, Potted-In Cable</p>	<p>C</p>  <p>18 mm - Embeddable, Stainless Steel Barrel, M12 Eurofast Connection</p>
<p>D</p>  <p>18 mm - Embeddable, Stainless Steel Barrel, M12 Eurofast Connection</p>	<p>E</p>  <p>30 mm - Embeddable, Stainless Steel Barrel, Potted-In Cable</p>
<p>F</p>  <p>30 mm - Embeddable, M12 Eurofast Connection, Stainless Steel</p>	

We reserve the right to make technical alterations without prior notice.

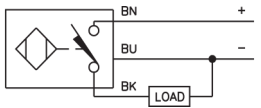
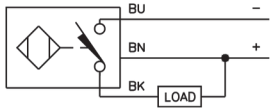
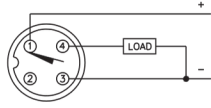
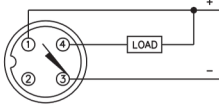
Wiring Diagrams/Mating Cordsets			
<p>1</p> 	<p>2</p> 	<p>3</p>  <p>Mating Cordset: RKV 4T-*</p>	<p>4</p>  <p>Mating Cordset: RKV 4T-*</p>

A6 3-wire DC Stainless Front Face (AP, AN, RP, RN)	
<ul style="list-style-type: none"> Ripple: $\leq 10\%$ Differential Travel (Hysteresis): 3-15% (5% typical) Voltage Drop Across Conducting Sensor: $\leq 1.8\text{ V}$ Trigger Current for Short Circuit Protection: $\geq 220\text{ mA}$ on 200 mA Load Current No-Load Current: $\leq 15\text{ mA}$ Off-State (Leakage) Current: $\leq 0.1\text{ mA}$ 	<ul style="list-style-type: none"> Temperature Drift: $\leq \pm 10\%$ Incorporated Incorporated 30 Reverse Polarity Protection: g, 11 ms 55 Hz, 1 mm Amplitude in all Wire-Break Protection: 3 Planes $\leq 2\%$ of Rated Operating Distance Shock: Distance Vibration: Repeatability:
A7 3-wire DC Stainless Front Face Ext Range (AP, AN, RP, RN)	
<ul style="list-style-type: none"> Ripple: $\leq 10\%$ Differential Travel (Hysteresis): 20% Voltage Drop Across Conducting Sensor: $\leq 2\text{ V}$ Trigger Current for Short Circuit Protection: $\geq 220\text{ mA}$ on 200 mA Load Current No-Load Current: $\leq 10\text{ mA}$ Off-State (Leakage) Current: $\leq 0.1\text{ mA}$ 	<ul style="list-style-type: none"> Temperature Drift: $\leq \pm 10\%$ Incorporated Incorporated 30 Reverse Polarity Protection: g, 11 ms 55 Hz, 1 mm Amplitude, in all Wire-Break Protection: 3 Planes $\leq 5\%$ of Rated Operating Distance Shock: Distance Vibration: Repeatability:

Stainless Steel Front Face | 18 mm, 30 mm

Embeddable Threaded Metal Barrels with 3-Wire DC Outputs

Part Number/ ID Number	Features	Sensing Range (mm)	Output	Voltage	Switching Freq. (Hz)	Operating Current (mA)	Operating Temp. (°C)	Protection	Housing	Face	Power LED	Output LED	Cable Length/Jacket	Wiring Diagrams Dimension Drawings	Spec List
Bi5-EG18F-AN6X 4614639	SSF	5	3-wire DC NPN	10-30 VDC	100	≤200	-25 to +70	IP68/69K	SS	SS	N/A	YE	2M/PVC	A 2	A6
Bi10-EG18F-AN6X 4614723	SSF	10	3-wire DC NPN	10-30 VDC	200	≤200	-25 to +70	IP68/69K	SS	SS	N/A	YE	2M/PVC	B 2	A7
Bi10-EG18F-AP6X 4614722	SSF	10	3-wire DC PNP	10-30 VDC	200	≤200	-25 to +70	IP68/69K	SS	SS	N/A	YE	2M/PVC	B 1	A7
Bi5-EG18F-AN6X-H1141 4614642	SSF	5	3-wire DC NPN	10-30 VDC	100	≤200	-25 to +70	IP68/69K	SS	SS	N/A	YE	--	C 4	A6
Bi5-EGT18F-AN6X-H1141 4614672	SSF, PTFE	5	3-wire DC NPN	10-30 VDC	100	≤200	-25 to +70	IP68/69K	TC	SS	N/A	YE	--	C 4	A6
Bi10-EG18F-AN6X-H1141 4614716	SSF	10	3-wire DC NPN	10-30 VDC	200	≤200	-25 to +70	IP68/69K	SS	SS	N/A	YE	--	D 4	A7
Bi5-EG18F-AP6X-H1141 4614641	SSF	5	3-wire DC PNP	10-30 VDC	100	≤200	-25 to +70	IP68/69K	SS	SS	N/A	YE	--	C 3	A6
Bi10-EG18F-AP6X-H1141 4614708	SSF, PTFE	5	3-wire DC PNP	10-30 VDC	100	≤200	-25 to +70	IP68/69K	TC	SS	N/A	YE	--	C 3	A6
Bi10-EGT18F-AP6X-H1141 4614708	SSF	10	3-wire DC PNP	10-30 VDC	200	≤200	-25 to +70	IP68/69K	SS	SS	N/A	YE	--	D 3	A7
	SSF, PTFE	10	3-wire DC PNP	10-30 VDC	200	≤200	-25 to +70	IP68/69K	TC	SS	N/A	YE	--	D 3	A7
Bi20-EG30F-AP6X 4614724	SSF	20	3-wire DC PNP	10-30 VDC	100	≤200	-25 to +70	IP68/69K	SS	SS	N/A	YE	2M/PVC	E 1	A7
Bi20-EG30F-AP6X-H1141 4614710	SSF	20	3-wire DC PNP	10-30 VDC	100	≤200	-25 to +70	IP68/69K	SS	SS	N/A	YE	--	F 3	A7
Bi20-EGT30F-AP6X-H1141 46147100	SSF, PTFE	20	3-wire DC PNP	10-30 VDC	100	≤200	-25 to +70	IP68/69K	TC	SS	N/A	YE	--	F 3	A7

We reserve the right to make technical alterations without prior notice.

Stainless Steel Front Face



stone face®

Turck's Stoneface sensors use a glass filled thermoset plastic material on the sensing face that:

- Protects the sensing face from abrasion
- Is resistant to weld slag buildup that is often a result of MIG/TIG welding
- Is available with PTFE coated barrels to shed weld slag

■ Protects against:



Impact



MIG/TIG Weld





Abrasion

We reserve the right to make technical alterations without prior notice.

Stoneface

Embeddable Metal Barrel

			
Housing	12 mm	18 mm	30 mm
Sensing Range	2 - 4 mm	5 - 8 mm	10 - 15 mm
Pages	72, 78	74, 78	76 - 78

Stoneface | 12 mm

Embeddable Threaded Metal Barrels with Cable and DC Outputs

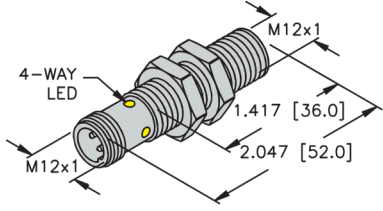
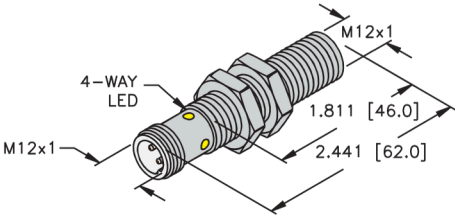
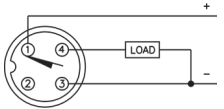
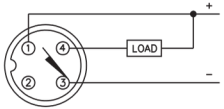
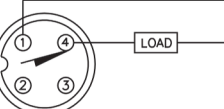
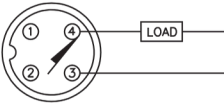
Housing Style	Dimension Drawings
	<p>A</p>  <p>12 mm - Embeddable, M12 Eurofast Connection</p>
<p>B</p>  <p>12 mm - Embeddable, M12 Eurofast Connection, Extended Barrel Length</p>	
Wiring Diagrams/Mating Cordsets	
<p>1</p>  <p>Mating Cordset: RK 4T-*; RKV 4T-*</p>	<p>2</p>  <p>Mating Cordset: RK 4T-*; RKV 4T-*</p>
<p>3</p>  <p>Mating Cordset: RK 4.23T-*</p>	<p>4</p>  <p>Mating Cordset: RK 4.2T-*</p>
A2 3 and 4-wire DC - (AN, RN, AP, RP, VN, VP)	
<p>Ripple: $\leq 10\%$</p> <p>Differential Travel (Hysteresis): 3-15% (5% typical)</p> <p>Voltage Drop Across Conducting Sensor: $\leq 1.8\text{ V}$</p> <p>Trigger Current for Short Circuit Protection:</p> <ul style="list-style-type: none"> $\geq 220\text{ mA}$ on 200 mA Load Current $\geq 170\text{ mA}$ on 150 mA Load Current $\geq 120\text{ mA}$ on 100 mA Load Current <p>Off-State (Leakage) Current: $\leq 0.1\text{ mA}$</p> <p>No-Load Current:</p> <ul style="list-style-type: none"> $\leq 15\text{ mA}$ (Ferrite, Uprox, Rectangular) $\leq 20\text{ mA}$ (Uprox+, Uprox 3) <p>Time Delay Before Availability: $\leq 8\text{ ms}$</p>	<p>Power-On Effect: Per IEC 947-5-2 Incorporated</p> <p>Reverse Polarity Protection: Incorporated Per EN 60947-5-2</p> <p>Wire-Break Protection: $\leq \pm 10\%$ 30 g, 11 ms 55 Hz, 1 mm</p> <p>Transient Protection: Amplitude in all 3 Planes $\leq 2\%$ of Rated Operating Distance</p> <p>Temperature Drift:</p> <p>Shock:</p> <p>Vibration:</p> <p>Repeatability:</p>
A3 2-wire DC - (AD, RD, AG)	
<p>Ripple: $\leq 10\%$</p> <p>Differential Travel (Hysteresis): 3-15% (5% typical)</p> <p>Voltage Drop Across Conducting Sensor:</p> <ul style="list-style-type: none"> Non-polarized (AD) $< 5.0\text{ V}$ Polarized (AG) $\leq 4.2\text{ V}$ <p>Trigger Current for Short Circuit Protection: $\geq 120\text{ mA}$</p> <p>Minimum Load Current: $\geq 3.0\text{ mA}$</p>	<p>Off-State (Leakage) Current: $\leq 0.8\text{ mA}$</p> <p>Power-On Effect: Per IEC 947-5-2</p> <p>Transient Protection: Per EN 60947-5-2</p> <p>Shock: 30 g, 11 ms</p> <p>Vibration: 55 Hz, 1 mm Amplitude in all 3 Planes</p> <p>Repeatability: $\leq 2\%$ of Rated Operating Distance</p>

We reserve the right to make technical alterations without prior notice.

Stoneface | 12 mm

Embeddable Threaded Metal Barrels with Cable and DC Outputs

Part Number/ ID Number	Features	Sensing Range (mm)	Output	Voltage	Switching Freq. (Hz)	Operating Current (mA)	Operating Temp. (°C)	Protection	Housing	Front Cap/Face	Power LED	Output LED	Dimension Drawings	Wiring Diagrams	Spec List
BI4-MT12H-AN6X-H1141 4607194	PTFE	4	3-wire DC NPN	10-30 VDC	2000	≤200	-25 to +70	IP67	TC	SF	N/A	YE	A	2	A2
BI4-MT12H-AP6X-H1141 4607093	PTFE	4	3-wire DC PNP	10-30 VDC	2000	≤200	-25 to +70	IP67	TC	SF	N/A	YE	A	1	A2
BI4-MT12HE-AN6X-H1141 4607197	PTFE	4	3-wire DC NPN	10-30 VDC	2000	≤200	-25 to +70	IP67	TC	SF	N/A	YE	B	2	A2
BI4-MT12HE-AP6X-H1141 4608093	PTFE	4	3-wire DC PNP	10-30 VDC	2000	≤200	-25 to +70	IP67	TC	SF	N/A	YE	B	1	A2
BI3U-EM12H-AP6X-H1141 1634312	Uprox	3	3-wire DC PNP	10-30 VDC	2000	≤200	-30 to +85	IP67	SS	SF	N/A	YE	A	1	A2
BI3U-EM12HE-AN6X2-H1141 1634311	Uprox	3	3-wire DC NPN	10-30 VDC	2000	≤200	-30 to +85	IP67	SS	SF	GN	YE	B	2	A2
BI3U-EM12HE-AP6X2-H1141 1634310	Uprox	3	3-wire DC PNP	10-30 VDC	2000	≤200	-30 to +85	IP67	SS	SF	GN	YE	B	1	A2
BI3U-MT12H-AP6X-H1141 1634212	Uprox, PTFE	3	3-wire DC PNP	10-30 VDC	2000	≤200	-30 to +85	IP67	TC	SF	N/A	YE	A	1	A2
BI3U-MT12HE-AN6X2-H1141 1634230	Uprox, PTFE	3	3-wire DC NPN	10-30 VDC	2000	≤200	-30 to +85	IP67	TC	SF	GN	YE	B	2	A2
BI3U-MT12HE-AP6X2-H1141 1634220	Uprox, PTFE	3	3-wire DC PNP	10-30 VDC	2000	≤200	-30 to +85	IP67	TC	SF	GN	YE	B	1	A2
BI3-MT12H-AD4X-H1144 44050983	PTFE	3	2-wire DC	10-65 VDC	1000	≤100	-25 to +70	IP67	TC	SF	N/A	YE	A	3	A3
BI3-MT12HE-AD4X-H1141 4405088	PTFE	3	2-wire DC	10-65 VDC	1000	≤100	-25 to +70	IP67	TC	SF	N/A	YE	B	4	A3

We reserve the right to make technical alterations without prior notice.

Stoneface

Stoneface | 18 mm

Embeddable Threaded Metal Barrels with Cable and DC Outputs

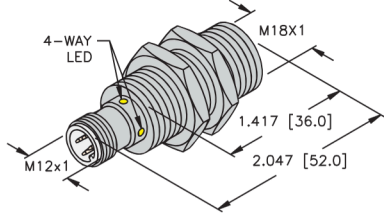
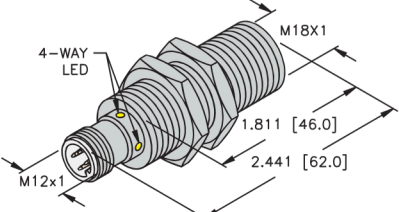
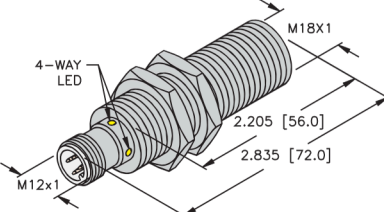
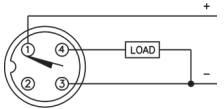
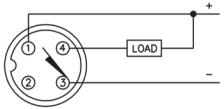
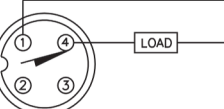
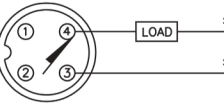
Housing Style	Dimension Drawings		
	<p>A</p>  <p>18 mm - Embeddable, M12 Eurofast Connection</p>		
<p>B</p>  <p>18 mm - Embeddable, M12 Eurofast Connection</p>	<p>C</p>  <p>18 mm - Embeddable, Ext. Barrel Length, M12 Eurofast Connection</p>		
Wiring Diagrams/Mating Cordsets			
<p>1</p>  <p>Mating Cordset: RK 4T-*; RKV 4T-*</p>	<p>2</p>  <p>Mating Cordset: RKV 4T-*</p>	<p>3</p>  <p>Mating Cordset: RK 4.23T-*</p>	<p>4</p>  <p>Mating Cordset: RK 4.2T-*</p>
A2 3 and 4-wire DC - (AN, RN, AP, RP, VN, VP)			
<p>Ripple: $\leq 10\%$</p> <p>Differential Travel (Hysteresis): 3-15% (5% typical)</p> <p>Voltage Drop Across Conducting Sensor: $\leq 1.8\text{ V}$</p> <p>Trigger Current for Short Circuit Protection:</p> <ul style="list-style-type: none"> $\geq 220\text{ mA}$ on 200 mA Load Current $\geq 170\text{ mA}$ on 150 mA Load Current $\geq 120\text{ mA}$ on 100 mA Load Current <p>Off-State (Leakage) Current: $\leq 0.1\text{ mA}$</p> <p>No-Load Current:</p> <ul style="list-style-type: none"> $\leq 15\text{ mA}$ (Ferrite, Uprox, Rectangular) $\leq 20\text{ mA}$ (Uprox+, Uprox 3) <p>Time Delay Before Availability: $\leq 8\text{ ms}$</p>	<p>Power-On Effect: Per IEC 947-5-2 Incorporated</p> <p>Reverse Polarity Protection: Incorporated Per EN 60947-5-2</p> <p>Wire-Break Protection: $\leq \pm 10\%$ 30 g, 11 ms 55 Hz, 1 mm</p> <p>Transient Protection: Amplitude in all 3 Planes $\leq 2\%$ of Rated Operating Distance</p> <p>Temperature Drift:</p> <p>Shock:</p> <p>Vibration:</p> <p>Repeatability:</p>		
A3 2-wire DC - (AD, RD, AG)			
<p>Ripple: $\leq 10\%$</p> <p>Differential Travel (Hysteresis): 3-15% (5% typical)</p> <p>Voltage Drop Across Conducting Sensor:</p> <ul style="list-style-type: none"> Non-polarized (AD) $< 5.0\text{ V}$ Polarized (AG) $\leq 4.2\text{ V}$ <p>Trigger Current for Short Circuit Protection: $\geq 120\text{ mA}$</p> <p>Minimum Load Current: $\geq 3.0\text{ mA}$</p>	<p>Off-State (Leakage) Current: $\leq 0.8\text{ mA}$</p> <p>Power-On Effect: Per IEC 947-5-2</p> <p>Transient Protection: Per EN 60947-5-2</p> <p>Shock: 30 g, 11 ms</p> <p>Vibration: 55 Hz, 1 mm Amplitude in all 3 Planes</p> <p>Repeatability: $\leq 2\%$ of Rated Operating Distance</p>		

We reserve the right to make technical alterations without prior notice.

Stoneface | 18 mm

Embeddable Threaded Metal Barrels with Cable and DC Outputs

Part Number/ ID Number	Features	Sensing Range (mm)	Output	Voltage	Switching Freq. (Hz)	Operating Current (mA)	Operating Temp. (°C)	Protection	Housing	Front Cap/Face	Power LED	Output LED	Dimension Drawings	Wiring Diagrams	Spec List
BI8-EM18H-AP6X-H1141 4615094		8	3-wire DC PNP	10-30 VDC	500	≤200	-25 to +70	IP67	SS	SF	N/A	YE	A	1	A2
BI8-EMT18H-AP6X-H1141 46150941	PTFE	8	3-wire DC PNP	10-30 VDC	500	≤200	-25 to +70	IP67	TC	SF	N/A	YE	A	1	A2
BI8-EM18HE-AN6X-H1141 4615194		8	3-wire DC NPN	10-30 VDC	500	≤200	-25 to +70	IP67	SS	SF	N/A	YE	C	2	A2
BI8-EM18HE-AP6X-H1141 4614100		8	3-wire DC PNP	10-30 VDC	500	≤200	-25 to +70	IP67	SS	SF	N/A	YE	C	1	A2
BI8-EMT18HE-AP6X-H1141 46150943	PTFE	8	3-wire DC PNP	10-30 VDC	500	≤200	-25 to +70	IP67	TC	SF	N/A	YE	C	1	A2
BI7-MT18H-AD4X-H1141 44145808	PTFE	7	2-wire DC	10-65 VDC	1000	≤100	-25 to +70	IP67	TC	SF	N/A	YE	B	4	A3
BI7-EM18HE-AD4X-H1141 44145802		7	2-wire DC	10-65 VDC	1000	≤100	-25 to +70	IP67	SS	SF	N/A	YE	C	4	A3
BI7-MT18HE-AD4X-H1141 4414597	PTFE	7	2-wire DC	10-65 VDC	1000	≤100	-25 to +70	IP67	TC	SF	N/A	YE	C	4	A3
BI5U-EM18H-AP6X-H1141 1635112	PTFE	7	2-wire DC	10-65 VDC	1000	≤100	-25 to +70	IP67	TC	SF	N/A	YE	C	3	A3
	Uprox	5	3-wire DC PNP	10-30 VDC	2500	≤200	-30 to +85	IP68	SS	SF	N/A	YE	A	2	A2
BI5U-EM18H-AN6X2-H1141/S395 1635146	Uprox	5	3-wire DC NPN	10-30 VDC	2500	≤200	-30 to +85	IP68	SS	SF	GN	YE	B	2	A2
BI5U-EM18H-AP6X2-H1141/S395 1635158	Uprox	5	3-wire DC PNP	10-30 VDC	2500	≤200	-30 to +85	IP68	SS	SF	GN	YE	B	1	A2
BI5U-MT18H-AP6X2-H1141/S395 1635220	Uprox, PTFE	5	3-wire DC PNP	10-30 VDC	2500	≤200	-30 to +85	IP68	TC	SF	GN	YE	B	1	A2
BI5-EM18H-AP6X-H1141 4614687		5	3-wire DC PNP	10-30 VDC	500	≤200	-25 to +70	IP67	SS	SF	N/A	YE	A	1	A2

We reserve the right to make technical alterations without prior notice.

Stoneface

Stoneface | 30 mm

Embeddable Threaded Metal Barrels with Cable and DC Outputs

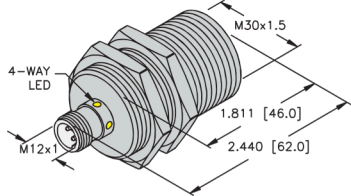
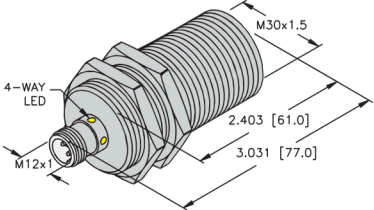
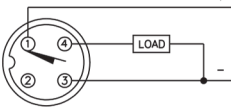
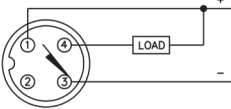
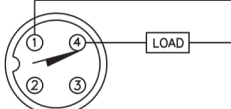
Housing Style	Dimension Drawings	
	<p>A</p>  <p>30 mm - Embeddable, M12 Eurofast Connection</p>	
<p>B</p>  <p>30 mm - Embeddable, M12 Eurofast Connection, Extended Barrel Length</p>		
Wiring Diagrams/Mating Cordsets		
<p>1</p>  <p>Mating Cordset: RK 4T-*, RKV 4T-*</p>	<p>2</p>  <p>Mating Cordset: RKV 4T-*</p>	<p>3</p>  <p>Mating Cordset: RK 4.23T-*</p>
A2 3 and 4-wire DC - (AN, RN, AP, RP, VN, VP)		
<p>Ripple: $\leq 10\%$</p> <p>Differential Travel (Hysteresis): 3-15% (5% typical)</p> <p>Voltage Drop Across Conducting Sensor: $\leq 1.8\text{ V}$</p> <p>Trigger Current for Short Circuit Protection: $\geq 220\text{ mA}$ on 200 mA Load Current $\geq 170\text{ mA}$ on 150 mA Load Current $\geq 120\text{ mA}$ on 100 mA Load Current</p> <p>Off-State (Leakage) Current: $\leq 0.1\text{ mA}$</p> <p>No-Load Current: $\leq 15\text{ mA}$ (Ferrite, Uprox, Rectangular) $\leq 20\text{ mA}$ (Uprox+, Uprox 3)</p> <p>Time Delay Before Availability: $\leq 8\text{ ms}$</p>	<p>Power-On Effect: Per IEC 947-5-2 Incorporated</p> <p>Reverse Polarity Protection: Incorporated Per EN 60947-5-2</p> <p>Wire-Break Protection: $\leq \pm 10\%$ 30 g, 11 ms 55 Hz, 1 mm</p> <p>Transient Protection: Amplitude in all 3 Planes $\leq 2\%$ of Rated Operating Distance</p> <p>Temperature Drift:</p> <p>Shock:</p> <p>Vibration:</p> <p>Repeatability:</p>	
A3 2-wire DC - (AD, RD, AG)		
<p>Ripple: $\leq 10\%$</p> <p>Differential Travel (Hysteresis): 3-15% (5% typical)</p> <p>Voltage Drop Across Conducting Sensor: Non-polarized (AD) $< 5.0\text{ V}$ Polarized (AG) $\leq 4.2\text{ V}$</p> <p>Trigger Current for Short Circuit Protection: $\geq 120\text{ mA}$</p> <p>Minimum Load Current: $\geq 3.0\text{ mA}$</p>	<p>Off-State (Leakage) Current: $\leq 0.8\text{ mA}$</p> <p>Power-On Effect: Per IEC 947-5-2</p> <p>Transient Protection: Per EN 60947-5-2</p> <p>Shock: 30 g, 11 ms</p> <p>Vibration: 55 Hz, 1 mm Amplitude in all 3 Planes</p> <p>Repeatability: $\leq 2\%$ of Rated Operating Distance</p>	

We reserve the right to make technical alterations without prior notice.

Stoneface | 30 mm

Embeddable Threaded Metal Barrels with Cable and DC Outputs

Part Number/ ID Number	Features	Sensing Range (mm)	Output	Voltage	Switching Freq. (Hz)	Operating Current (mA)	Operating Temp. (°C)	Protection	Housing	Front Cap/Face	Power LED	Output LED	Dimension Drawings	Wiring Diagrams	Spec List
BI15-EMT30H-AP6X-H1141 4618570	PTFE	15	3-wire DC PNP	10-30 VDC	300	≤200	-25 to +70	IP67	TC	SF	N/A	YE	A	1	A2
BI15-EM30H-AN6X-H1141 4618692		15	3-wire DC NPN	10-30 VDC	300	≤200	-25 to +70	IP67	SS	SF	N/A	YE	A	2	A2
BI15-EM30H-AP6X-H1141 4618592		15	3-wire DC PNP	10-30 VDC	300	≤200	-25 to +70	IP67	SS	SF	N/A	YE	A	1	A2
BI12-MT30H-AD4X-H1144 4417095	PTFE	12	2-wire DC	10-65 VDC	500	≤100	-25 to +70	IP67	TC	SF	N/A	YE	A	3	A3
BI10U-MT30H-AP6X2-H1141 1636220	Uprox, PTFE	10	3-wire DC PNP	10-30 VDC	1000	≤200	-30 to +85	IP67	TC	SF	GN	YE	A	1	A2
BI10U-EM30HE-AP6X2-H1141 1636415	Uprox	10	3-wire DC PNP	10-30 VDC	2000	≤200	-30 to +85	IP67	SS	SF	GN	YE	B	1	A2

We reserve the right to make technical alterations without prior notice.

Stoneface

Stoneface | 12, 18, and 30 mm

Embeddable Threaded Metal Barrels with Connector and AC/DC Outputs

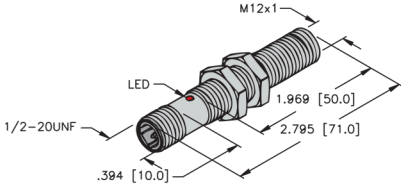
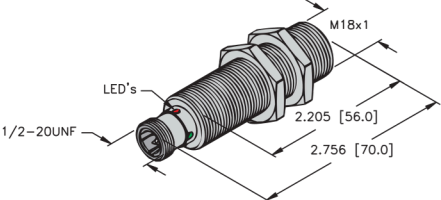
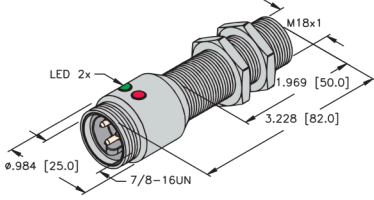
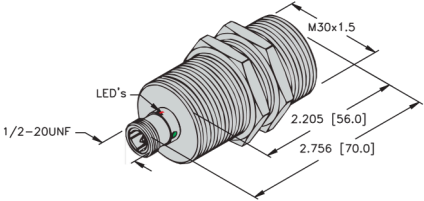
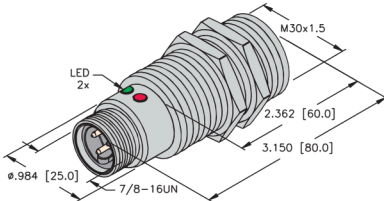
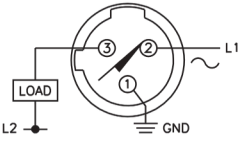
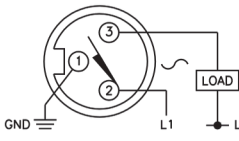
Housing Style	Dimension Drawings
	<p>A</p>  <p>12 mm - Embeddable, 1/2" Microfast Connection</p>
<p>B</p>  <p>18 mm - Embeddable, 1/2" Microfast Connection</p>	<p>C</p>  <p>18 mm - Embeddable, 7/8" Minifast Connection</p>
<p>D</p>  <p>30 mm - Embeddable, 1/2" Microfast Connection</p>	<p>E</p>  <p>30 mm - Embeddable, 7/8" Minifast Connection</p>
Wiring Diagrams/Mating Cordsets	
<p>1</p>  <p>Mating Cordset: KB 3T-*</p>	<p>2</p>  <p>Mating Cordset: RKM 30-*M</p>
A4 2-wire AC/DC w/ Short-Circuit Protection - (ADZ, RDZ, FDZ, VDZ)	
<p>Line Frequency: $\geq 50 \dots \leq 60$ Hz</p> <p>Differential Travel (Hysteresis): 3-15% (5% typical)</p> <p>Voltage Drop Across Conducting Sensor: ≤ 6.0 V</p> <p>Trigger Current for Short Circuit Protection: AC: ≥ 440 mA; DC: ≥ 330 mA AC: ≥ 120 mA; DC: ≥ 120 mA</p> <p>Continuous Load Current: AC: ≤ 400 mA; DC: ≤ 300 mA AC: ≤ 100 mA; DC: ≤ 100 mA</p> <p>Off-State (Leakage) Current: ≤ 1.7 mA (AC) ≤ 1.5 mA (DC)</p>	<p>Minimum Load Current: ≥ 3.0 mA</p> <p>Inrush Current: ≤ 3 A (≤ 20 ms, max 5 Hz)</p> <p>Power-On Effect: Per IEC 947-5-2</p> <p>Transient Protection: Per EN 60947-5-2</p> <p>Shock: 30 g, 11 ms</p> <p>Vibration: 55 Hz, 1 mm Amplitude, in all 3 Planes</p> <p>Repeatability: $\leq 2\%$ of Rated Operating Distance</p>

We reserve the right to make technical alterations without prior notice.

Stoneface | 12, 18, and 30 mm

Embeddable Threaded Metal Barrels with Connector and AC/DC Outputs

Part Number/ ID Number	Features	Sensing Range (mm)	Output	Voltage	Switching Freq. (Hz)	Operating Current (mA)	Operating Temp. (°C)	Protection	Housing	Front Cap/Face	Power LED	Output LED	Dimension Drawings	Wiring Diagrams	Spec List
BI4- GT12H-ADZ32X-B3131 4205097	PTFE	4	2-wire AC/DC Short-Circuit Protected	20-250 VAC/10-300 VDC	20	≤100	-25 to +70	IP67	TC	SF	N/A	RD	A	1	A4
BI2- GT12H-ADZ32X-B3131/S34 4205093	PTFE, WFI	2	2-wire AC/DC Short-Circuit Protected	20-250 VAC/10-300 VDC	20	≤100	-25 to +70	IP67	TC	SF	N/A	RD	A	1	A4
BI5- GT18H-ADZ30X2-B3331/S34 4255289	PTFE, WFI	5	2-wire AC/DC Short-Circuit Protected	20-250 VAC/10-300 VDC	20	≤400/300	-25 to +70	IP67	TC	SF	GN	RD	B	1	A4
BI5- GT18H-ADZ30X2-B1331/S34 4255299	PTFE, WFI	5	2-wire AC/DC Short-Circuit Protected	20-250 VAC/10-300 VDC	20	≤400/300	-25 to +70	IP67	TC	SF	GN	RD	C	2	A4
BI10- GT30H-ADZ30X2-B3131/S34 4256094	PTFE, WFI	10	2-wire AC/DC Short-Circuit Protected	20-250 VAC/10-300 VDC	20	≤400/300	-25 to +70	IP67	TC	SF	GN	RD	D	1	A4
BI15-EG30H-ADZ30X2-B3131 4207284		15	2-wire AC/DC Short-Circuit Protected	20-250 VAC/10-300 VDC	10	≤400/300	-25 to +70	IP67	SS	SF	GN	RD	D	1	A4
BI15-EG30H-ADZ30X2-B1131 4207292		15	2-wire AC/DC Short-Circuit Protected	20-250 VAC/10-300 VDC	10	≤400/300	-25 to +70	IP67	SS	SF	GN	RD	E	2	A4

We reserve the right to make technical alterations without prior notice.



Stoneface



Nut Detection Sensor



Turck's weld nut sensors provide efficient and economical detection of weld nuts in automotive applications:

- Rejection-free process for detecting weld nuts
- An economical alternative to more expensive optical or vision-based systems that often malfunction due to:
 - Dirt and weldsplatter residue
 - Frequently changing lighting conditions in welding zones
- Rugged construction delivers dependable performance
- PTFE coated versions available
- Titanium Nitride coated probe versions available
- Simple programming
- Bright LEDs indicate the output status

We reserve the right to make technical alterations without prior notice.

Nut Detection Sensor

Nut Detection Sensor Selection Guide

			
Housing	12 mm		
Sensing Range	5 - 10 mm	6 - 12 mm	10 - 20 mm
Pages	82	82	82

Weld Nut Detection Sensor

Threaded Metal Barrel with Smooth Sensing Probe and 3-Wire DC Output

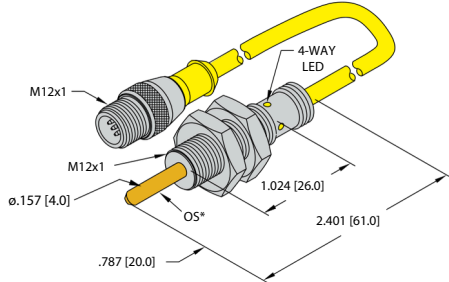
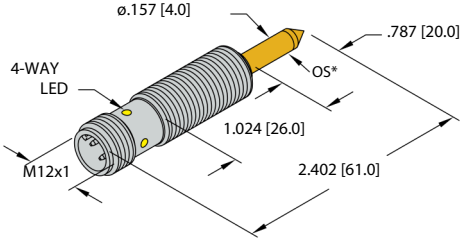
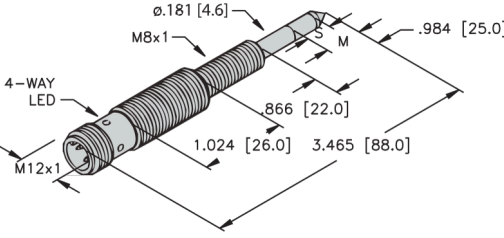
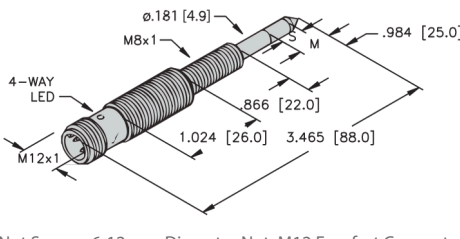
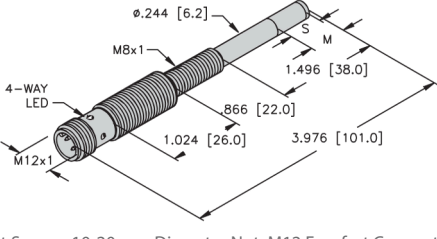
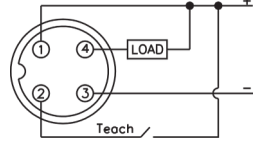
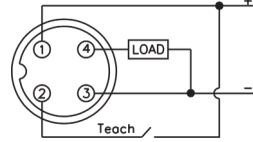
Housing Style	Dimension Drawings
	<p>A</p>  <p>Nut Sensor, 5-12 mm Diameter Nut, Potted-In Cable</p>
<p>B</p>  <p>Nut Sensor, 5-12 mm Diameter Nut, M12 Eurofast Connector</p>	<p>C</p>  <p>Nut Sensor, 6-12 mm Diameter Nut, M12 Eurofast Connector</p>
<p>D</p>  <p>Nut Sensor, 6-12 mm Diameter Nut, M12 Eurofast Connector</p>	<p>E</p>  <p>Nut Sensor, 10-20 mm Diameter Nut, M12 Eurofast Connector</p>
Wiring Diagrams/Mating Cordsets	
<p>1</p>  <p>Mating Cordset: RK 4.4T-*</p>	<p>2</p>  <p>Mating Cordset: RK 4.4T-*</p>
A8 3-wire DC Nut Detection Sensor (AP, AN)	
<p>Ripple: $\leq 10\%$ Voltage Drop Across Conducting Sensor: $\leq 1\text{ V}$ Trigger Current for Short Circuit Protection: $\geq 220\text{ mA}$ on 200 mA Load Current No-Load Current: $\leq 15\text{ mA}$ Off-State (Leakage) Current: $\leq 0.1\text{ mA}$</p>	<p>Reverse Polarity Protection: Incorporated Wire-Break Protection: Incorporated Shock: 30 g, 11 ms Vibration: 55 Hz, 1 mm Amplitude, in all 3 Planes</p>

Note:

OS* The optimal sensitive area for the 4.0 mm diameter probes has a width of 0.5 mm and is laser-engraved on the tip of the probe, 11.9 mm above the M12 thread.

S** Sensitive area: Within this area the sensor signal changes when assembly parts are changed.

M*** Maximum area: The maximum signal intensity is reached if the sensitive area is completely covered.

Optional teach adapter available, part number VB2-SP1.

We reserve the right to make technical alterations without prior notice.

Weld Nut Detection Sensor

Threaded Metal Barrel with Smooth Sensing Probe and 3-Wire DC Output

Part Number/ ID Number	Features	Output	Voltage	Operating Current (mA)	Operating Temp. (°C)	Protection	Housing	Power LED	Output LED	Cable Length/Jacket	Wiring Diagrams Dimension Drawings	Spec List
NIMFE-EM12/4.0L61-UP6X-0.3XYE-RS4/S1182 1600623	Titanium Nitride	3-wire DC PNP	10-30 VDC	≤200	-25 to +70	IP67	SS	GN	YE	0.3M/TPE	A 2	A8
NIMFE-EM12/4.0L61-UN6X-0.3XYE-RS4/S1182 1600624	Titanium Nitride	3-wire DC NPN	10-30 VDC	≤200	-25 to +70	IP67	SS	GN	YE	0.3M/TPE	A 1	A8
NIMFE-EM12/4.0L61-UP6X-H1141/S1182 1600621	Titanium Nitride	3-wire DC PNP	10-30 VDC	≤200	-25 to +70	IP67	SS	GN	YE	--	B 2	A8
NIMFE-EM12/4.0L61-UN6X-H1141/S1182 1600622	Titanium Nitride	3-wire DC NPN	10-30 VDC	≤200	-25 to +70	IP67	SS	GN	YE	--	B 1	A8
NIMFE-M12/4.6L88-UN6X-H1141 1600610		3-wire DC NPN	10-30 VDC	≤200	-25 to +70	IP67	CPB	GN	YE	--	C 1	A8
NIMFE-EMT12/4.6L88-UN6X-H1141 1600618	PTFE Coated	3-wire DC NPN	10-30 VDC	≤200	-25 to +70	IP67	SS	GN	YE	--	C 1	A8
NIMFE-EM12/4.6L88-UN6X-H1141/S1182 1600617	Titanium Nitride	3-wire DC NPN	10-30 VDC	≤200	-25 to +70	IP67	SS	GN	YE	--	C 1	A8
NIMFE-M12/4.6L88-UP6X-H1141 1600608		3-wire DC PNP	10-30 VDC	≤200	-25 to +70	IP67	CPB	GN	YE	--	C 2	A8
NIMFE-EMT12/4.6L88-UP6X-H1141/S1182 1600619	PTFE Coated	3-wire DC PNP	10-30 VDC	≤200	-25 to +70	IP67	SS	GN	YE	--	C 2	A8
	Titanium Nitride	3-wire DC PNP	10-30 VDC	≤200	-25 to +70	IP67	SS	GN	YE	--	C 2	A8
NIMFE-EM12/4.9L88-UP6X-H1141/S1182 1600616	Titanium Nitride	3-wire DC PNP	10-30 VDC	≤200	-25 to +70	IP67	SS	GN	YE	--	D 2	A8
NIMFE-M12/6.2L101-UN6X-H1141 1600611		3-wire DC NPN	10-30 VDC	≤200	-25 to +70	IP67	CPB	GN	YE	--	E 1	A8
NIMFE-EMT12/6.2L101-UN6X-H1141 1600615	PTFE Coated	3-wire DC NPN	10-30 VDC	≤200	-25 to +70	IP67	SS	GN	YE	--	E 1	A8
NIMFE-M12/6.2L101-UP6X-H1141 1600609		3-wire DC PNP	10-30 VDC	≤200	-25 to +70	IP67	CPB	GN	YE	--	E 2	A8
NIMFE-EMT12/6.2L101-UP6X-H1141 1600613	PTFE Coated	3-wire DC PNP	10-30 VDC	≤200	-25 to +70	IP67	SS	GN	YE	--	E 2	A8
NIMFE-EM12/6.2L101-UP6X-H1141/S1182 1600612	Titanium Nitride	3-wire DC PNP	10-30 VDC	≤200	-25 to +70	IP67	SS	GN	YE	--	E 2	A8

We reserve the right to make technical alterations without prior notice.

Nut Detection Sensor

"/S1182" = Titanium Nitride coated probe.



Instrumentation

Flow Monitors for Weld Tip Protection

- Flow monitors are used in the welding industry to monitor flow of liquids and gases
- Based on the Calorimetric flow principle
- No moving parts



Pressure Sensors for Weld Cell Automation

- Hydraulic or pneumatic monitoring
- Fully programmable output, functionality, scaling, and display
- Stainless steel housing
- Pressure ranges up to 600 Bar

We reserve the right to make technical alterations without prior notice.

Instrumentation

Instrumentation Selection Guide

			
Housing	Self-Contained Monitor	Air Flow Monitor	Pressure Sensor
Pages	86	86	88-90

Instrumentation

Flow Sensors

Dimension Drawings

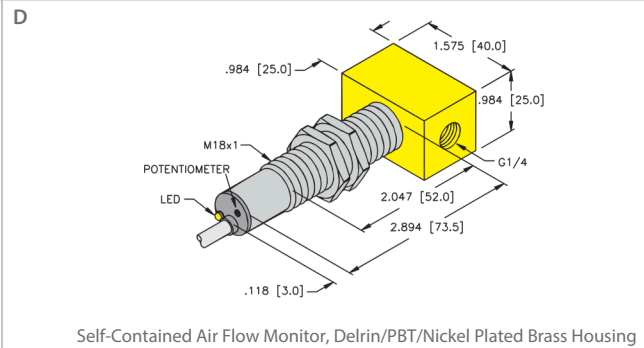
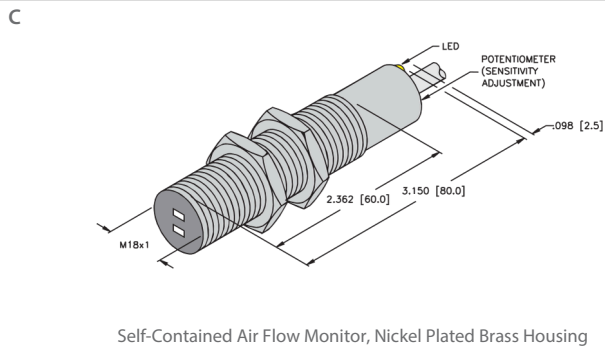
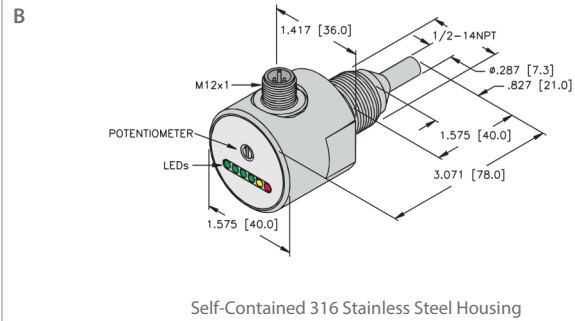
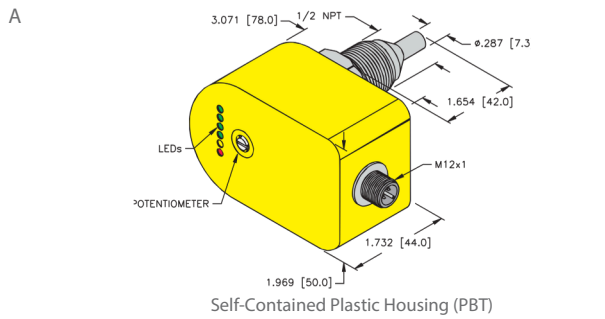

Wiring Diagrams/Mating Cordsets

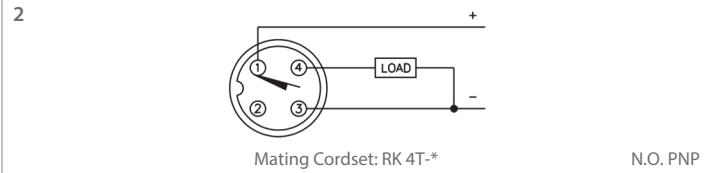
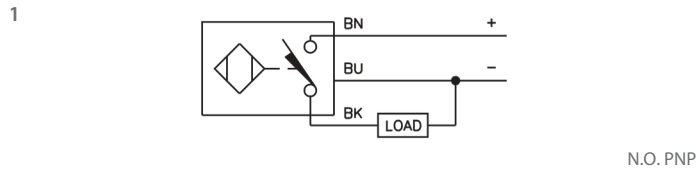

We reserve the right to make technical alterations without prior notice.

Instrumentation

Flow Sensors

Part Number/ ID Number	(water) Flow Deflection Range	(air) Flow Deflection Range	Flow Detection Range	Voltage (mA)	Current Consumption	Switching Current (mA)	Pressure Rating (psi)	Process Connection (ambient)	Operating Temp. (°C)	Operating Temp. (°C)	Protection	Cable Length (mw)	Housing Material	Sensor Material	Dimension Drawings	Wiring Diagrams
FCS-N1/2A4P-AP8X-H1141 M6871032	1-150 cm/sec.	3-300 cm/sec.	--	19.2-28.8 VDC	≤60	≤400	1450	1/2 NPT	-25 to +70	-20 to +80	IP67	--	Plastic, PBT	Stainless Steel, V4A (1.4571)	A	2
FCS-N1/2A4-AP8X-H1141 M6871004	1-150 cm/sec.	3-300 cm/sec.	--	19.2-28.8 VDC	≤70	≤400	1450	1/2 NPT	-25 to +80	-20 to +80	IP67	--	Stainless Steel, V4A (1.4571)	Stainless Steel, V4A (1.4571)	B	2
FCS-M18-AP8X M6870704	--	--	0.5 - 15 m/sec.	19.2-28.8 VDC	≤70	≤200	145	M18x1	-25 to +70	-25 to +70	IP67	2	Metal, CuZn	Brass, nickel-plated	C	1
FCS-M18-AP8X/D041 M6870705	--	--	0.1 - 15 m/sec.	19.2-28.8 VDC	≤70	≤200	145	M18x1	-25 to +70	-25 to +70	IP67	2	Metal, CuZn	Brass, nickel-plated	D	1

We reserve the right to make technical alterations without prior notice.

Instrumentation

PS500 Programmable Pressure Sensors, Rotatable Housing

Housing Style	Dimension Drawings
	

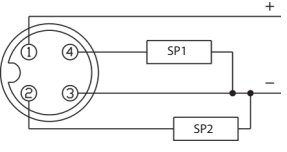
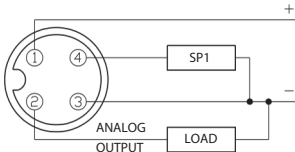
Wiring Diagrams/Mating Cordsets	
<p>1</p>  <p>Mating Cordset: RK 4.4T-*</p>	<p>2</p>  <p>Mating Cordset: RK 4.4T-*</p>

Performance Data
<p>Analog Accuracy LHR: $\pm 0.5\%$ of Full Scale ($\pm 1\%$ of Full Scale for PS0.25V) $\pm 0.5\%$ of Full Scale ($\pm 1\%$ of Full Scale for PS0.25V)</p> <p>Set point Accuracy: 0.5% of Span $\leq 0.15\%$ of Measuring Range per 10 °C 0-90% of Measuring Range</p> <p>Set Point Hysteresis: Range 10-100% of Measuring Range 1-100% of Pressure Range 0.5-99.5% of Pressure</p> <p>Temperature Coefficient: Range 0-20 mA, 4-20 mA, 20-0 mA, 20-4 mA, 0-5 VDC, 1-6 VKC, 5-0 VDC, 10 VDC, 6-1 VDC and 1X PNP/NPN N.O./N.C or 2X PNP/NPN N.O./N.C 2X PNP/NPN N.O./N.C</p> <p>Programmable Analog Start Point:</p> <p>Programmable Analog End Point:</p> <p>Switch Point Range:</p> <p>Reset Point Range:</p> <p>Programmable Output for LI2UPN8X:</p>
<p>Programmable Output for 2UPNX:</p>

Electrical Data
<p>Operating Voltage: 18-30 VDC</p> <p>Current Consumption: ≤ 50 mA</p> <p>Voltage Drop: ≤ 2 V</p> <p>Analog Load: $\leq 500 \Omega$</p> <p>Switching Frequency: ≤ 180 Hz</p> <p>Response Time: < 3 ms</p> <p>Short Circuit/Reverse Polarity Protection: Yes/Yes</p>

Environmental Data
<p>Ambient Temperature: -40 to +80 °C -40 to +80 °C -40 to +85 °C</p> <p>Storage Temperature: Stainless-steel/Plastic, 303 Stainless Steel</p> <p>Medium Temperature: 303 Stainless Steel, FPM, AL2O3 Ceramic</p> <p>Housing Materials: IP67/IP69K/III 50 g (11 ms), per IEC 61508</p> <p>Wetted Materials: 20 g (9-2000Hz) per IEC 68-2-6 4 digit 7</p> <p>Protection Type: Segment Display</p> <p>Shock Resistance:</p> <p>Vibration Resistance:</p> <p>LED Measuring Value:</p>

We reserve the right to make technical alterations without prior notice.

Instrumentation

PS500 Programmable Pressure Sensors, Rotatable Housing

Part Number	Operating Pressure	Over Pressure	Burst Pressure	Wiring Diagram
PS0.25V-503-LI2UPN8X-H1141 6833211	-0.25-0.25 Bar (-1-0 PSIG)	≤3 Bar (≤43.5 PSIG)	≥3 Bar (≤43.5 PSIG)	2
PS01VR-503-LI2UPN8X-H1141 6833280	-1-0 Bar (-14.5-14.5 PSIG)	≤5.5 Bar (≤80 PSIG)	≥5.5 Bar (≤80 PSIG)	2
PS001R-503-LI2UPN8X-H1141 6832281	0-1 Bar (0-14.5 PSIG)	≤5.5 Bar (≤80 PSIG)	≥5.5 Bar (≤80 PSIG)	2
PS001V-503-LI2UPN8X-H1141 6832827	-1-1 Bar (-14.5-14.5 PSIG)	≤5.5 Bar (≤80 PSIG)	≥5.5 Bar (≤80 PSIG)	2
PS003V-503-LI2UPN8X-H1141 6832828	-1-3 Bar (-14.5-43.5 PSIG)	≤12 Bar (≤174 PSIG)	≥12 Bar (≤174 PSIG)	2
PS010V-503-LI2UPN8X-H1141 6832829	-1-10 Bar (-14.5-145 PSIG)	≤50 Bar (≤725 PSIG)	≥50 Bar (≤725 PSIG)	2
PS016V-503-LI2UPN8X-H1141 6832830	-1-16 Bar (-14.5-232 PSIG)	≤40 Bar (≤580 PSIG)	≥40 Bar (≤580 PSIG)	2
PS025V-503-LI2UPN8X-H1141 6832831	-1-25 Bar (-14.5-362.5 PSIG)	≤110 Bar (≤1595 PSIG)	≥110 Bar (≤1595 PSIG)	2
PS040V-503-LI2UPN8X-H1141 6832832	-1-40 Bar (-14.5-580 PSIG)	≤180 Bar (≤2110 PSIG)	≥180 Bar (≤2110 PSIG)	2
PS100R-503-LI2UPN8X-H1141 6832287	0-100 Bar (0-1450 PSIG)	≤420 Bar (≤6092 PSIG)	≥420 Bar (≤6092 PSIG)	2
PS250R-503-LI2UPN8X-H1141 6832288	0-250 Bar (0-3625 PSIG)	≤500 Bar (≤7252 PSIG)	≥500 Bar (≤7252 PSIG)	2
PS400R-503-LI2UPN8X-H1141 6832289	0-400 Bar (0-5800 PSIG)	≤700 Bar (≤10153 PSIG)	≥700 Bar (≤10153 PSIG)	2
PS600R-503-LI2UPN8X-H1141 6832833	0-600 Bar (0-8700 PSIG)	≤900 Bar (≤13053 PSIG)	≥900 Bar (≤13053 PSIG)	2
PS0.25V-503-2UPNX-H1141 6833212	-0.25-0.25 Bar (-1-0 PSIG)	≤3 Bar (≤43.5 PSIG)	≥3 Bar (≤43.5 PSIG)	1
PS01VR-503-2UPNX-H1141 6832658	-1-0 Bar (-14.5-14.5 PSIG)	≤5.5 Bar (≤80 PSIG)	≥5.5 Bar (≤80 PSIG)	1
PS001R-503-2UPNX-H1141 6832659	0-1 Bar (0-14.5 PSIG)	≤5.5 Bar (≤80 PSIG)	≥5.5 Bar (≤80 PSIG)	1
PS001V-503-2UPNX-H1141 6832660	-1-1 Bar (-14.5-14.5 PSIG)	≤5.5 Bar (≤80 PSIG)	≥5.5 Bar (≤80 PSIG)	1
PS003V-503-2UPNX-H1141 6832661	-1-3 Bar (-14.5-43.5 PSIG)	≤12 Bar (≤174 PSIG)	≥12 Bar (≤174 PSIG)	1
PS010V-503-2UPNX-H1141 6832662	-1-10 Bar (-14.5-145 PSIG)	≤50 Bar (≤725 PSIG)	≥50 Bar (≤725 PSIG)	1
PS016V-503-2UPNX-H1141 6832663	-1-16 Bar (-14.5-232 PSIG)	≤40 Bar (≤580 PSIG)	≥40 Bar (≤580 PSIG)	1
PS025V-503-2UPNX-H1141 6832664	-1-25 Bar (-14.5-362.5 PSIG)	≤110 Bar (≤1595 PSIG)	≥110 Bar (≤1595 PSIG)	1
PS040V-503-2UPNX-H1141 6832665	-1-40 Bar (-14.5-580 PSIG)	≤180 Bar (≤2110 PSIG)	≥180 Bar (≤2110 PSIG)	1
PS100R-503-2UPNX-H1141 6832666	0-100 Bar (0-1450 PSIG)	≤420 Bar (≤6092 PSIG)	≥420 Bar (≤6092 PSIG)	1
PS250R-503-2UPNX-H1141 6832667	0-250 Bar (0-3625 PSIG)	≤500 Bar (≤7252 PSIG)	≥500 Bar (≤7252 PSIG)	1
PS400R-503-2UPNX-H1141 6832668	0-400 Bar (0-5800 PSIG)	≤700 Bar (≤10153 PSIG)	≥700 Bar (≤10153 PSIG)	1
PS600R-503-2UPNX-H1141 6832669	0-600 Bar (0-8700 PSIG)	≤900 Bar (≤13053 PSIG)	≥900 Bar (≤13053 PSIG)	1

We reserve the right to make technical alterations without prior notice.

Instrumentation

Instrumentation

PS300 Programmable Pressure Sensors, Non-Rotatable Housing

Housing Style	Dimension Drawings
	

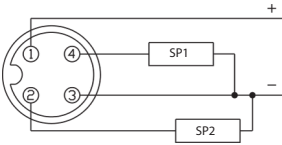
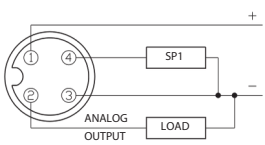
Wiring Diagrams/Mating Cordsets	
<p>1</p>  <p>Mating Cordset: RK 4.4T-*</p>	<p>2</p>  <p>Mating Cordset: RK 4.4T-*</p>

Performance Data

Analog Accuracy LHR: $\pm 0.5\%$ of Full Scale ($\pm 1\%$ of Full Scale for PS0.25V) $\pm 0.5\%$ of Full Scale ($\pm 1\%$ of Full Scale for PS0.25V)
 Set point Accuracy: 0.5% of Span $\leq 0.15\%$ of Measuring Range per 10 °C 0-90% of Measuring Range
 Set Point Hysteresis: Range 10-100% of Measuring Range 1-100% of Pressure Range 0.5-99.5% of Pressure
 Temperature Coefficient: Range 0-20 mA, 4-20 mA, 20-0 mA, 20-4 mA, 0-5 VDC, 1-6 VKC, 5-0 VDC, 10 VDC, 6-1 VDC and 1X PNP/NPN N.O./N.C or 2X PNP/NPN N.O./N./C 2X PNP/NPN N.O./N.C
 Programmable Analog Start Point:
 Programmable Analog End Point:
 Switch Point Range:
 Reset Point Range:
 Programmable Output for LI2UPN8X:
 Programmable Output for 2UPNX:

Electrical Data

Operating Voltage: 18-30 VDC
 Current Consumption: ≤ 50 mA
 Voltage Drop: ≤ 2 V
 Analog Load: $\leq 500 \Omega$
 Switching Frequency: ≤ 180 Hz
 Response Time: < 3 ms
 Short Circuit/Reverse Polarity Protection: Yes/Yes

Environmental Data

Ambient Temperature: -40 to +80 °C -40 to +80 °C -40 to +80 °C
 Storage Temperature: +85 °C Stainless-steel/Plastic, V2A
 Medium Temperature: (1.4305) 303 Stainless Steel, Plastic
 Housing Materials: IP67/IP69K/III 50 g (11 ms), per IEC
 Wetted Materials: 61508 20 g (9-2000Hz) per IEC 68-
 Protection Type: 2-6 4 digit 7 Segment Display
 Shock Resistance:
 Vibration Resistance:
 LED Measuring Value:

We reserve the right to make technical alterations without prior notice.

Instrumentation

PS300 Programmable Pressure Sensors, Non-Rotatable Housing

Part Number	Operating Pressure	Over Pressure	Burst Pressure	Wiring Diagram
PS01VR-303-LI2UPN8X-H1141 6833402	-1-0 Bar (-14.5-14.5 PSIG)	≤5.5 Bar (≤80 PSIG)	≥5.5 Bar (≤80 PSIG)	2
PS001V-303-LI2UPN8X-H1141 6833404	-1-1 Bar (-14.5-14.5 PSIG)	≤5.5 Bar (≤80 PSIG)	≥5.5 Bar (≤80 PSIG)	2
PS003V-303-LI2UPN8X-H1141 6833405	-1-3 Bar (-14.5-43.5 PSIG)	≤12 Bar (≤174 PSIG)	≥12 Bar (≤174 PSIG)	2
PS010V-303-LI2UPN8X-H1141 6833406	-1-10 Bar (-14.5-145 PSIG)	≤50 Bar (≤725 PSIG)	≥50 Bar (≤725 PSIG)	2
PS016V-303-LI2UPN8X-H1141 6833407	-1-16 Bar (-14.5-232 PSIG)	≤40 Bar (≤580 PSIG)	≥40 Bar (≤580 PSIG)	2
PS025V-303-LI2UPN8X-H1141 6833408	-1-25 Bar (-14.5-362.5 PSIG)	≤110 Bar (≤1595 PSIG)	≥110 Bar (≤1595 PSIG)	2
PS040V-303-LI2UPN8X-H1141 6833409	-1-40 Bar (-14.5-580 PSIG)	≤180 Bar (≤2110 PSIG)	≥180 Bar (≤2110 PSIG)	2
PS100R-303-LI2UPN8X-H1141 6833410	-1-40 Bar (-14.5-580 PSIG)	≤180 Bar (≤2110 PSIG)	≥180 Bar (≤2110 PSIG)	2
PS250R-303-LI2UPN8X-H1141 6833411	0-100 Bar (0-1450 PSIG)	≤420 Bar (≤6092 PSIG)	≥420 Bar (≤6092 PSIG)	2
PS400R-303-LI2UPN8X-H1141 6833412	0-250 Bar (0-3625 PSIG)	≤500 Bar (≤7252 PSIG)	≥500 Bar (≤7252 PSIG)	2
	0-400 Bar (0-5800 PSIG)	≤700 Bar (≤10153 PSIG)	≥700 Bar (≤10153 PSIG)	2
PS600R-303-LI2UPN8X-H1141 6833413	0-600 Bar (0-8700 PSIG)	≤900 Bar (≤13053 PSIG)	≥900 Bar (≤13053 PSIG)	2
PS001R-303-LI2UPN8X-H1141 6833403	0-1 Bar (0-14.5 PSIG)	≤5.5 Bar (≤80 PSIG)	≥5.5 Bar (≤80 PSIG)	2
PS01VR-303-2UPNX-H1141 6833414	-1-0 Bar (-14.5-14.5 PSIG)	≤5.5 Bar (≤80 PSIG)	≥5.5 Bar (≤80 PSIG)	1
PS001R-303-2UPNX-H1141 6833415	0-1 Bar (0-14.5 PSIG)	≤5.5 Bar (≤80 PSIG)	≥5.5 Bar (≤80 PSIG)	1
PS001V-303-2UPNX-H1141 6833416	-1-1 Bar (-14.5-14.5 PSIG)	≤5.5 Bar (≤80 PSIG)	≥5.5 Bar (≤80 PSIG)	1
PS003V-303-2UPNX-H1141 6833417	-1-3 Bar (-14.5-43.5 PSIG)	≤12 Bar (≤174 PSIG)	≥12 Bar (≤174 PSIG)	1
PS010V-303-2UPNX-H1141 6833418	-1-10 Bar (-14.5-145 PSIG)	≤50 Bar (≤725 PSIG)	≥50 Bar (≤725 PSIG)	1
PS016V-303-2UPNX-H1141 6833419	-1-16 Bar (-14.5-232 PSIG)	≤40 Bar (≤580 PSIG)	≥40 Bar (≤580 PSIG)	1
PS025V-303-2UPNX-H1141 6833420	-1-25 Bar (-14.5-362.5 PSIG)	≤110 Bar (≤1595 PSIG)	≥110 Bar (≤1595 PSIG)	1
PS040V-303-2UPNX-H1141 6833421	-1-40 Bar (-14.5-580 PSIG)	≤180 Bar (≤2110 PSIG)	≥180 Bar (≤2110 PSIG)	1
PS100R-303-2UPNX-H1141 6833422	-1-40 Bar (-14.5-580 PSIG)	≤180 Bar (≤2110 PSIG)	≥180 Bar (≤2110 PSIG)	1
PS250R-303-2UPNX-H1141 6833423	0-100 Bar (0-1450 PSIG)	≤420 Bar (≤6092 PSIG)	≥420 Bar (≤6092 PSIG)	1
PS400R-303-2UPNX-H1141 6833424	0-250 Bar (0-3625 PSIG)	≤500 Bar (≤7252 PSIG)	≥500 Bar (≤7252 PSIG)	1
PS600R-303-2UPNX-H1141 6833425	0-400 Bar (0-5800 PSIG)	≤700 Bar (≤10153 PSIG)	≥700 Bar (≤10153 PSIG)	1
	0-600 Bar (0-8700 PSIG)	≤900 Bar (≤13053 PSIG)	≥900 Bar (≤13053 PSIG)	1

We reserve the right to make technical alterations without prior notice.

Instrumentation

Notes

A large, empty grid area intended for taking notes. The grid consists of small, uniform squares, typical of graph paper or a digital note-taking application. The grid covers the majority of the page below the 'Notes' header.



Connectivity

Weld Slag Protection

Turck Connectivity offers many different levels of weld slag protection, including:

- PE, TPE, Aramid overbraided, or Armor cables
- TFE coated coupling nuts
- Protective sleeving, tubing and tape

We reserve the right to make technical alterations without prior notice.

Connectivity

Cordset Selection Guide					
Style	Picofast	Eurofast	Eurofast Aramid	Microfast	Minifast
Pages	97	98-102	99-100	103	104

Cordset Accessories Selection Guide					
Style	Fiberglass Sleeve	Silicone Sleeve	Silicone Tube	Weld Shield Sleeve	Weld Seal Tape
Pages	105	106	106	107	107

Mating Cordset Selection Guide

Attributes	Instrumentation Tray Cable		General Purpose Cable		Instrumentation Tray/Exposed Run/Direct Burial Cable	
Material:	PVC -40 to	TPE -40 to	PVC -40 to	TPU -40 to	PVC	TPE
Temp Range:	105 °C -40 °C	105 °C -40 °C	105 °C -40 °C	90 °C -40 °C	-40 to 105 °C	-40 to 105 °C
Cold Bend:	--- --- Fair	--- ---	--- --- Fair	--- ---	-40 °C	-40 °C
Cold Impact:	Excellent	Fair/Good	Excellent	Excellent	---	---
Crush and Impact:		Excellent	UL 1061/CSA	Poor/Fair	Excellent	Excellent
Cut and Abrasion:			FT1	UL 1061/	Good	Fair/Good
UV/Sunlight Resistant:			Poor	CSA FT1	Excellent	Excellent
			Very Good	Poor		
Flame Retardant:	UL 1685/CSA FT4	UL 1685/CSA FT4	Very Good	Very Good	UL 1685/CSA FT4	UL 1685/CSA FT4
			Good	Good		
Weld Slag/Spatter:	Poor	Very Good	Very Good	Good	Poor	Very Good
Water:	Very Good	Very Good	Very Good	Good	Very Good	Very Good
			Very Good	Good		
Flexibility:	Very Good	Very Good	Fair	Good	Fair	Good
Flexlife:	Good	Good	Good	Fair	Fair	Fair/Good
Oils:	Excellent	Excellent	Good	Poor/Fair	Very Good	Excellent
Greases:	Excellent	Excellent		Fair	Very Good	Excellent
Gasoline:	Fair	Good			Poor	Good
Alcohols:	Good	Very Good			Very Good	Very Good
Acids <20%:	Good	Poor			Good	Poor
General Approvals:	UL ITC, PLTC, AWM CSA AWM CMX OUTDOOR-CMG, MSHA 300 V, 600 V	UL ITC, PLTC, AWM CSA AWM CMX OUT- DOOR-CMG, MSHA 300 V, 600 V	UL/CSA, AWM, MSHA 300 V or 600 V	UL/CSA, AWM, MSHA 300 V or 600 V	UL ITC, PLTC, ERDB, AWM, CSA CIC or CMX OUT- DOOR-CM AWM, Marine Shipboard UL 1309, IEEE 1580-2010, CSA 245, ABS, 300 V, 600 V	UL ITC, PLTC, ERDB, AWM CSA CMX OUTDOOR-CMG 150 V, 300 V, 600 V

We reserve the right to make technical alterations without prior notice.

- Attributes are general statements for materials at room temperature. Each application should be evaluated individually.
- Temperature, the percentage of chemical present, type of chemical exposure, and installation practices will all affect performance. For specific recommendations, please contact Turck.

Mating Cordset Selection Guide

Attributes	Extremelife Cable EX60 -60 to	Flexlife Cable		Weldlife Cable
Material:	105 °C -60 °C -40 °C Excellent	TPE -40 to 105 °C	TPU -40 to 90 °C	TPE -40 to 105 °C
Temp Range:	Very Good Excellent UL	-40 °C --- ---	-40 °C --- ---	-40 °C --- ---
Cold Bend:	1685/CSA FT4 IEC 60332-3-22	Fair/Good	Excellent	Fair/Good
Cold Impact:	Good Very Good Good Very	Excellent UL	Poor/Fair UL	Excellent UL
Crush and Impact:	Good Excellent Excellent Good	1061/CSA FT1	1061/CSA FT1	1061/CSA FT1
Cut and Abrasion:	Excellent Good	Very Good Very	Poor Very Good	Very Good Very
UV/Sunlight Resistant:		Good Excellent	Good Good	Good Very Good
Flame Retardant:		Excellent	Good Good Fair	Good Excellent
Weld Slag/Spatter:		Excellent	Poor/Fair Fair	Excellent Good
Water:		Excellent Good		Very Good Poor
Flexibility:		Very Good Poor		
Flexlife:				
Oils:				
Greases:				
Gasoline:				
Alcohols:				
Acids <20%:				
General Approvals:	UL TC-ERDB, ITC, PLTC, ERDB, CSA CIC/TC Marine Shipboard UL 1309, IEEE 1580-2010, ABS, 300 V, 600 V	UL/CSA, AWM 300 V or 600 V	UL/CSA, AWM 300 V or 600 V	UL/CSA, AWM 300 V or 600 V

We reserve the right to make technical alterations without prior notice.

- Attributes are general statements for materials at room temperature. Each application should be evaluated individually.
- Temperature, the percentage of chemical present, type of chemical exposure, and installation practices will all affect performance. For specific recommendations, please contact Turck.

Connectivity

Mating Cordset Selection Guide

Attributes	Aramid Overbraided Cable	Armorfast Instrumentation Cable	Flexible Service Cable	Halogen Free Cable/Low Smoke Cable
Material:	TPE with Aramid overbraid	PVC -40 to 105 °C -40 °C ---	PVC -40 to 105 °C -40	TPU -40 to 80 °C -40 °C --- --- Excellent
Temp Range:	-40 to 105 °C (200 °C spikes)	Excellent Good Excellent	°C --- --- Good	Poor/Fair
Cold Bend:	-40 °C --- --- Good/Very	UL 1685/CSA FT4	Excellent	UL 1061/CSA FT1
Cold Impact:	Good Excellent	Poor	UL Horizontal	Poor Very Good Good Good Good Good
Crush and Impact:	UL 1061/CSA FT1	Very Good	Flame/CSA FT2	Fair Poor/Fair Fair
Cut and Abrasion:	Excellent Very Good Very	Fair	Poor	
UV/Sunlight Resistant:	Good Good Excellent	Poor	Very Good	
Flame Retardant:	Excellent Good Very Good	Very Good	Good	
Weld Slag/Spatter:	Poor	Very Good	Very Good	
Water:		Poor	Very Good	
Flexibility:		Very Good	Poor	
Flexlife:		Good	Very Good	
Oils:			Good	
Greases:				
Gasoline:				
Alcohols:				
Acids <20%:				
General Approvals:	UL/CSA, AWM 300 V or 600 V	UL MC, ITC, PLTC, ERDB, CSA ACIC, 300 V, 600 V, HL ABCD	UL/CSA, STOOW MSHA, 600 V	UL/CSA, AWM 300 V

- Attributes are general statements for materials at room temperature. Each application should be evaluated individually.
- Temperature, the percentage of chemical present, type of chemical exposure, and installation practices will all affect performance. For specific recommendations, please contact Turck.

We reserve the right to make technical alterations without prior notice.

M8 Picofast Connectivity

3-Wire Cordsets, Threaded Coupling Nut

- NEMA 1, 3, 4, 6P
- IEC IP67 Protection
- 125 V, 4 A



Connector Style	Female Part Number	Male Part Number	Features	Pinout
<p>PKG ..Z**</p>	<p>PKG 3M-* PKW 3M-*</p>	<p>PSG 3M-* PSW 3M-*</p>	<p>AWM, PVC Yellow, 3x24 AWG, 105 °C, 4.4 mm OD, Flexlife®</p>	<p>Female</p> <p>1. BN 3. BU 4. BK</p>
	<p>PKG 3M-*/S90 PKW 3M-*/S90</p>	<p>PSG 3M-*/S90 PSW 3M-*/S90</p>	<p>AWM, TPU Black, 3x24 AWG, 90 °C, 4.2 mm OD, Cut/Abrasion Immune</p>	
<p>PKW ..M**</p>	<p>PKG 3M-*/S90/S101 PKW 3M-*/S90/S101</p>	<p>PSG 3M-*/S90/S101 PSW 3M-*/S90/S101</p>	<p>AWM, TPU Black, 3x24 AWG, 90 °C, 4.4 mm OD, Cut/Abrasion Immune, Flexlife-20, High Flex - Over 20 Million Cycles</p>	
	<p>PKG 3M-*/S90/S618 PKW 3M-*/S90/S618</p>	<p>PSG 3M-*/S90/S618 PSW 3M-*/S90/S618</p>	<p>AWM, TPU Black, 3x24 AWG, 90 °C, 4.2 mm OD, Cut/Abrasion Immune, EMI/RFI Protection</p>	
<p>PSG ..M**</p>	<p>PKG 3M-*/S1587 PKW 3M-*/S1587</p>	<p>PSG 3M-*/S1587 PSW 3M-*/S1587</p>	<p>AWM, TPE Yellow, 3x24 AWG, 105 °C, 4.4 mm OD, Weldlife®, Weld Flash Immune</p>	
	<p>PKG 3M-*/S760 PKW 3M-*/S760</p>	<p>PSG 3M-*/S760 PSW 3M-*/S760</p>	<p>AWM, PVC Black, 3x24 AWG, 4.2 mm OD, Flexlife</p>	
<p>PSW ..M**</p>	<p>PKG 3M-*/S90/S1084 PKW 3M-*/S90/S1084</p>	<p>PSG 3M-*/S90/S1084 PSW 3M-*/S90/S1084</p>	<p>AWM, TPU Black, 2x24 AWG, 90 °C, 4.2 mm OD, Cut/Abrasion Immune, Shielded</p>	<p>Male</p> <p>1. BN 3. BU 4. Drain</p>
	<p>PKG 3M-*/S90/S1084 PKW 3M-*/S90/S1084</p>	<p>PSG 3M-*/S90/S1084 PSW 3M-*/S90/S1084</p>	<p>AWM, TPU Black, 2x24 AWG, 90 °C, 4.2 mm OD, Cut/Abrasion Immune, Shielded</p>	

We reserve the right to make technical alterations without prior notice.

Connectivity

* Length in meters. Standard cable lengths are 2, 4, 5, 6, 8 and 10 meters.
 **Standard coupling material is nickel plated brass.. "PKG..M"; "PKG..M" indicates stainless steel.

M12 Eurofast Connectivity

2-Wire Cordsets, Standard Plug Body

- NEMA 1, 3, 4, 6P
- IEC IP68 Protection
- 250 V, 4 A



Connector Style	Female Part Number	Male Part Number	Features	Pinout
<p>RK ..**</p>	RK 4.2T-* WK 4.2T-*	RS 4.2T-* WS 4.2T-*	ITC/PLTC PVC Grey, 2x20 AWG, 105 °C, 5.1 mm OD, Flexlife®	1. N/C 2. N/C 3. BN 4. BU
<p>WK ..**</p>	RK 4.2T-*/S90 WK 4.2T-*/S90	RS 4.2T-*/S90 WS 4.2T-*/S90	AWM TPU Grey, 2x20 AWG, 90 °C, 4.8 mm OD, Cut/Abrasion Immune	<p>Female</p>
<p>RS ..**</p>	RK 4.2T-*/S748 WK 4.2T-*/S748	RS 4.2T-*/S748 WS 4.2T-*/S748	ITC/PLTC PVC Yellow, 2x22 AWG, 105 °C, 5.1 mm OD, Flexlife	
<p>WS ..**</p>	RK 4.22T-* WK 4.22T-*	RS 4.22T-* WS 4.22T-*	ITC/PLTC PVC Grey, 2x20 AWG, 105 °C, 5.1 mm OD, Flexlife	1. BN 2. N/C 3. BU 4. N/C
	RK 4.23T-* WK 4.23T-*	RS 4.23T-* WS 4.23T-*		1. BN 2. N/C 3. N/C 4. BU

We reserve the right to make technical alterations without prior notice.

* Length in meters. Standard cable lengths are 2, 4, 5, 6, 8 and 10 meters. Consult factory for other lengths.

**Standard coupling nut material is nickel plated brass "RK .."; "RKK .." indicates nylon and "RKV .." indicates stainless steel.

Add "/S1077" to end of part number for silicone tubing assembled to pigtail or extension cordsets up to 4 meters (0.5 meter min. on extensions).

M12 Eurofast Connectivity

3-Wire Cordsets, Standard Plug Body

- NEMA 1, 3, 4, 6P
- IEC IP68 Protection
- 250 V, 4 A



Connector Style	Female Part Number	Male Part Number	Features	Pinout
<p>RK ..**</p>	RK 4T-*/S3415 WK 4T-*/S3415	RS 4T-*/S3415 WS 4T-*/S3415	Yellow Aramid overbraid, AWM TPE black, 3x22 AWG, 105 °C, 5.1 mm OD, Weld Flash Immune Flame Resistance	<p>Female</p>
	RK 4T-*/† WK 4T-*/†	RS 4T-*/† WS 4T-*/†	ITC/PLTC PVC Grey, 3x20 AWG, 105 °C, 5.1 mm OD, Flexlife®	
<p>WK ..**</p>	RK 4T-*/S90 WK 4T-*/S90	RS 4T-*/S90 WS 4T-*/S90	AWM TPU Grey, 3x22 AWG, 90 °C, 4.8 mm OD, Cut/Abrasion Immune	
	RK 4T-*/S101 WK 4T-*/S101	RS 4T-*/S101 WS 4T-*/S101	AWM TPE Grey, 3x22 AWG, 105 °C, 4.8 mm OD, Flexlife-20, High Flex Over 20 Million Cycles	
<p>RS ..**</p>	RK 4T-*/S529 WK 4T-*/S529	RS 4T-*/S529 WS 4T-*/S529	TPU/Heavy Braid Double Jacket Yellow, 3x22 AWG, 90 °C, 4.8 mm OD, Cut/Abrasion Immune Braided Mechanical Shield	
	RK 4T-*/S715 WK 4T-*/S715	RS 4T-*/S715 WS 4T-*/S715	ITC/PLTC PVC Yellow, 3x22 AWG, 105 °C, 5.1 mm OD, Flexlife	
<p>WS ..**</p>	RK 4T-*/S760 WK 4T-*/S760	RS 4T-*/S760 WS 4T-*/S760	ITC/PLTC PVC Black, 3x22 AWG, 105 °C, 5.1 mm OD, Flexlife	<p>Male</p>
	RK 4T-*/S618 WK 4T-*/S618	RS 4T-*/S618 WS 4T-*/S618	ITC/PLTC PVC Grey, 3x22 AWG, Foil/Drain, 105 °C, 5.1 mm OD, RFI/EMI Shielding, Tray Rated	

We reserve the right to make technical alterations without prior notice.



Connectivity

* Length in meters. Standard cable lengths are 2, 4, 5, 6, 8 and 10 meters. Consult factory for other lengths.
 **Standard coupling nut material is nickel plated brass "RK .."; "RKK .." indicates nylon and "RKV .." indicates stainless steel.
 Add "/S1077" to end of part number for silicone tubing assembled to pigtail or extension cordsets up to 4 meters (0.5 meter min. on extensions).
 † Available with TPU cable with PTFE protective tubing by adding /S1291. Max length for this option is 5 meters.

M12 Eurofast Connectivity

4-Wire Cordsets, Standard Plug Body

- NEMA 1, 3, 4, 6P
- IEC IP68 Protection
- 250 V, 4 A



Connector Style	Female Part Number	Male Part Number	Features	Pinout
<p>RK ..**</p> <p>1.673 [42.5] ϕ.571 [14.5]</p> <p>M12x1</p>	RK 4.4T-*/S3415 WK 4.4T-*/S3415	RS 4.4T-*/S3415 WS 4.4T-*/S3415	Yellow Aramid overbraid, AWM TPE black, 4x22 AWG, 105 C, 5.1 mm OD, Weld Flash Immune Flame Resistance	<p>Female</p> <p>1. BN 2. WH 3. BU 4. BK</p>
<p>WK ..**</p> <p>1.280 [32.5] .984 [25.0]</p> <p>.591 [15.0]</p> <p>M12x1</p>	RK 4.4T-*/S1587 WK 4.4T-*/S1587	RS 4.4T-*/S1587 WS 4.4T-*/S1587	ITC/PLTC TPE Yellow, 4x22 AWG, 105 °C, 5.3 mm OD, Weld Flash Immune, Flame Resistance	
<p>RS ..**</p> <p>1.546 [39.3] ϕ.571 [14.5]</p> <p>M12x1</p>	RK 4.4T-† WK 4.4T-†	RS 4.4T-† WS 4.4T-†	ITC/PLTC PVC Grey, 4x20 AWG, 105 °C, 5.1 mm OD, Flexlife®	<p>Male</p>
<p>WS ..**</p> <p>1.264 [32.1] 1.220 [31.0]</p> <p>ϕ.531 [13.5]</p> <p>M12x1</p>	RK 4.4T-*/S90 WK 4.4T-*/S90	RS 4.4T-*/S90 WS 4.4T-*/S90	AWM TPU Grey, 4x22 AWG, 90 °C, 4.8 mm OD, Cut/Abrasion Immune	
<p>WS ..**</p> <p>1.264 [32.1] 1.220 [31.0]</p> <p>ϕ.531 [13.5]</p> <p>M12x1</p>	RK 4.4T-*/S101 WK 4.4T-*/S101	RS 4.4T-*/S101 WS 4.4T-*/S101	AWM TPE Grey, 4x22 AWG, 105 °C, 4.8 mm OD, Flexlife-20, High Flex Over 20 Million Cycles	

We reserve the right to make technical alterations without prior notice.

Dimension Drawings	Part Number	Features	Wiring Diagrams	Pinouts
<p>.600 [15.3] M12x1</p> <p>M12x1 2x 1.281 [32.6]</p>	VBRS 4.4-2RK 4T-*/S3415	Yellow aramid overbraid, AWM TPE black, 3x22 AWG, 105 °C, 5.1 mm OD. Combine two sensors into one cable. Connects directly to Eurofast junction box.		<p>Female 4-pin</p> <p>Male 4-pin</p>

* Length in meters. Standard cable lengths are 2, 4, 5, 6, 8 and 10 meters. Consult factory for other lengths.

**Standard coupling nut material is nickel plated brass "RK .."; "RKK .." indicates nylon and "RKV .." indicates stainless steel.

Add "/S1077" to end of part number for silicone tubing assembled to pigtail or extension cordsets up to 4 meters (0.5 meter min. on extensions).

† Available with TPU cable with PTFE protective tubing by adding /S1291. Max length for this option is 5 meters.

M12 Eurofast Connectivity

2, 3, 4-Wire Cordsets, "C" Style, Medium Plug Body, "G" Style, Large Plug Body

- NEMA 1, 3, 4, 6P
- IEC IP68 Protection
- 250 V, 4 A



Connector Style	Female Part Number	Male Part Number	Features	Pinout	
<p>RKC ..**</p>	RKC 4.2T-* WKC 4.2T-*	RSC 4.2T-* WSC 4.2T-*	ITC/PLTC PVC Yellow, 2x18 AWG, 105 °C, 6.2 mm OD, Flexlife	1. N/C 2. N/C 3. BN 4. BU	<p>Female</p>
<p>WKC ..**</p>	RKC 4T-* WKC 4T-*	RSC 4T-* WSC 4T-*	ITC/PLTC PVC Yellow, 3x18 AWG, 105 °C, 6.2 mm OD, Flexlife	1. BN 2. N/C 3. BU 4. BK	
<p>WKC ..**</p>	RKC 4.4T-*/S1587 WKC 4.4T-*/S1587	RSC 4.4T-*/S1587 WKC 4.4T-*/S1587	ITC/PLTC TPU Yellow, 4x18 AWG, 105 °C, 6.9 mm OD, Weld Flash Immune, Flexlife	1. BN 2. WH 3. BU 4. BK	<p>Male</p>
<p>RSC ..**</p>	RKG 4T-*	RSG 4T-*	ITC/PLTC PVC Yellow, 3x18 AWG, 105 °C, 6.2 mm OD, Flexlife, tray rated	1. BN 2. N/C 3. BU 4. BK	
<p>RKG ..**</p>	RKG 4-*/S600	RSG 4T-*/S600	SJOOW, CPE Yellow, 3.18 AWG, 105 °C, 8.0 mm OD, Weld Flash Immune, Flame Resistance		

We reserve the right to make technical alterations without prior notice.

Connectivity

* Length in meters. Standard cable lengths are 2, 4, 5, 6, 8 and 10 meters. Consult factory for other lengths.
 **Standard coupling nut material is nickel plated brass "RK .."; "RKC .." indicates nylon and "RKV .." indicates stainless steel.
 Add "/S1077" to end of part number for silicone tubing assembled to pigtail or extension cordsets up to 4 meters (0.5 meter min. on extensions).
 Add "/S1092" to end of part number for PTFE coated coupling nuts.

M12 Eurofast Connectivity

4-Wire Cordsets with PNP to NPN Converter

- NEMA 1, 3, 4, 6P
- IEC IP68 Protection
- 24 VDC, 0.1 A
- PNP to NPN Signal Conversion



Connector Style	Female Part Number	Features	Pinout
<p>RKE ..**</p>	RKE 4.4T-*/S849/PNP-NPN WKE 4.4T-*/S849/PNP-NPN	ITC/PLTC PVC Grey, 4.22 AWG, 105 °C, 5.3 mm OD, Flexlife	<p>Female</p>
	RKE 4.4T-*/S90/S849/PNP-NPN WKC 4.4T-*/S90/S849/PNP-NPN	AWM TPU Grey 4x22 AWG, 90 °C, 5.1 mm OD, Cut/Abrasion Immune	
<p>WKC ..**</p>	RKE 4.4T-*/S849/S1587/PNP-NPN WKC 4.4T-*/S849/S1587/PNP-NPN	ITC/PLTC TPE Yellow, 4x22 AWG, 105 °C, 5.3 mm OD, Weld Flash Immune, Flame Resistance	

* Length in meters. Standard cable lengths are 2, 4, 5, 6, 8 and 10 meters. Consult factory for other lengths.

**Standard coupling nut material is nickel plated brass "RK .."; "RKK .." indicates nylon and "RKV .." indicates stainless steel.

Add "/S1077" to end of part number for silicone tubing assembled to pigtail or extension cordsets up to 4 meters (0.5 meter min. on extensions).

Add "/S1092" to end of part number for PTFE coated coupling nuts.

We reserve the right to make technical alterations without prior notice.

1/2" Microfast Connectivity

3-Wire Cordsets, Standard Duty and Large Plug Body

- NEMA 1, 3, 4, 6P
- IEC IP67 Protection
- 250 V, 4 A



Connector Style	Female Part Number	Male Part Number	Features	Pinout
<p>KB ..*</p>	KB 3T-* WKB 3T-*	SB 3T-* WSB 3T-*	ITC/PLTC PVC Yellow, 3x22 AWG, 105 °C, 5.1 mm OD	<p>Female</p>
<p>WKB ..**</p>	KB 3T-*/S90 WKB 3T-*/S90	SB 3T-*/S90 WSB 3T-*/S90	AWM TPU Yellow, 3x18 AWG, 90 °C, 5.3 mm OD, Cut/Abrasion Immune	
<p>KBE ..**</p>	KBE 3T-*/S600 WKBE 3T-*/S600	SBE 3T-*/S600 WSBE 3T-*/S600	SJOOW CPE Yellow, 3x18 AWG, 105 °C, 8.0 mm OD, Weld Flash Immune, Flame Immune	<p>1. GN 2. RD/BK 3. RD/WH</p>
<p>KBE ..**</p>	KBE 3T-*/S1587 WKBE 3T-*/S1587	SBE 3T-*/S1587 WSBE 3T-*/S1587	ITC/PLTC PVC Yellow, 3x18 AWG, 105 °C, 6.2 mm OD, Weldlife, Weld Flash Immune	<p>Male</p>
<p>WKBE ..**</p>	KB 3T-*/S1507 WKB 3T-*/S1507	SB 3T-*/S1507 WSB 3T-*/S1507	AWM TPE Grey, 3x22 AWG 105 °C, 4.8 mm OD, Flexlife-20, High Flex - Over 20 million cycles	

We reserve the right to make technical alterations without prior notice.

Connectivity

* Length in meters. Standard cable lengths are 2, 4, 6, 8 and 10 meters. Consult factory for other lengths.

**Standard coupling nut material is nickel plated brass "KB .."; "KBK .." indicates nylon and "KBV .." indicates stainless steel.

7/8" Minifast Connectivity Products

2 and 3-Wire Cordsets, Standard & Heavy Duty

- NEMA 1, 3, 4, 6P
- IEC IP67 Protection
- 9 A



Connector Style	Female Part Number	Male Part Number	Features	Pinout
<p>RKM ..**</p>	RKM 31-*M WKM 31-*M	RSM 31-*M WSM 31-*M	ITC/PLTC PVC Yellow, 3x18 AWG, 105 °C, 6.2 mm OD, Flexlife, 600 V	<p>1. BK 2. BN 3. BU</p>
<p>WKM ..**</p>	RKM 31-*M/S600 WKM 31-*M/S600	RSM 31-*M/S600 WSM 31-*M/S600	SJOOW CPE Yellow, 3x18 AWG, 105 °C, 8.0 mm OD, Weld Flash Immune, Flame Immune, 300 V	
<p>RKM 30-*M WKM 30-*M</p>	RKM 30-*M/S90 WKM 30-*M/S90	RSM 30-*M/S90 WSM 30-*M/S90	ITC/PLTC PVC Yellow, 3x18 AWG, 105 °C, 6.2 mm OD, Flexlife, 600 V	<p>1. GN/YE 2. BN 3. BU</p>
<p>RSM ..**</p>	RKM 30-*M/S101 WKM 30-*M/S101	RSM 30-*M/S101 WSM 30-*M/S101	AWM TPU Yellow, 3x18 AWG, 90 °C, 6.0 mm OD, Cut Abrasion Immune, 600 V	
<p>RKM 30-*M/S90 WKM 30-*M/S90</p>	RKM 30-*M/S101 WKM 30-*M/S101	RSM 30-*M/S101 WSM 30-*M/S101	AWM TPE Yellow, 3x18 AWG, 105 °C, 5.7 mm OD, Flexlife-20, high flex over 20 million cycles, 600 V C-track	<p>1. GN 2. RD/BK 3. RD/WH</p>
<p>RSM ..**</p>	RKM 311-*M WKM 311-*M	RSM 311-*M WSM 311-*M	ITC/PLTC PVC Yellow, 3x18 AWG, 105 °C, 6.2 mm OD, Flexlife, 600 V	
<p>WSM ..**</p>	RKM 311-*M/S600 WKM 311-*M/S600	RSM 311-*M/S600 WSM 311-*M/S600	SJOOW CPE, Yellow, 3x18 AWG, 105 °C, 8.0 mm OD, Weld Flash Immune, Flame Immune, 300 V	

* Length in meters. Standard cable lengths are 2, 4, 5, 6, 8 and 10 meters. Consult factory for other lengths.

**Standard coupling nut material is nickel plated brass "RKM .."; "RK .." indicates nylon, "RKV .." indicates stainless steel, and "RKVH .." indicates stainless steel hex.

We reserve the right to make technical alterations without prior notice.

Connectivity Accessories

Braided Fiberglass Sleeving



We reserve the right to make technical alterations without prior notice.

Part Number	Specifications	Application	Features
FFV 1/4INCH BLACK 50 FOOT ROLL [†] FFV 1/4INCH BLACK (10/BAG-6IN) [†]	Viton (fluoroelastomer) coated, braided fiberglass, black, 1/4" diameter, -70 to +220 °C, NEMA TF-1	Protective sleeving for insulation of cable.	Excellent chemical and solvent resistance. Coating offers improved flexibility and protection throughout a wide operating temperature range.
FFV 3/8INCH BLACK 50 FOOT ROLL [†] FFV 3/8INCH BLACK (10/BAG-6IN) [†]	Viton (fluoroelastomer) coated, braided fiberglass, black, 3/8" diameter, -70 to +220 °C, NEMA TF-1		
FFV 1/2INCH BLACK 50 FOOT ROLL [†] FFV 1/2INCH BLACK (10/BAG-6IN) [†]	Viton (fluoroelastomer) coated, braided fiberglass, black, 1/2" diameter, -70 to +220 °C, NEMA TF-1		
FFV 5/8INCH BLACK 50 FOOT ROLL [†] FFV 5/8INCH BLACK (10/BAG-6IN) [†]	Viton (fluoroelastomer) coated, braided fiberglass, black, 5/8" diameter, -70 to +220 °C, NEMA TF-1		
FFV 1INCH BLACK 50 FOOT ROLL [†] FFV 1INCH BLACK (10/BAG-6IN) [†]	Viton (fluoroelastomer) coated, braided fiberglass, black, 1" diameter, -70 to +220 °C, NEMA TF-1		
FFV 1 1/2INCH BLACK 50 FOOT ROLL [†] FFV 1 1/2INCH BLACK (10/BAG-6IN) [†]	Viton (fluoroelastomer) coated, braided fiberglass, black, 1 1/2" diameter, -70 to +220 °C, NEMA TF-1		

Connectivity

Braided Fiberglass Sleeving Acryl-Coated (Bulk)

Part Number	Specifications	Application	Features
FF 3/4INCH BLACK (10/BAG) [†] FF 3/4INCH BLACK 50 FOOT ROLL [†]	Acryl-coated, braided fiberglass, 3/4" diameter, -70 to +240 °C, NEMA TF-1	Protective sleeving for insulation of cable.	Excellent chemical and solvent resistance.
FF 1/2INCH BLACK (10/BAG) [†] FF 1/2INCH BLACK 50 FOOT ROLL [†]	Acryl-coated, braided fiberglass, 1/2" diameter, -70 to +240 °C, NEMA TF-1		

[†] Sleeving part numbers only; cordset not included.

Connectivity Accessories

Expandable Silicone Rubber Coated, Fiberglass Sleeving (Bulk)



Part Number	Specifications	Application	Features
FFFS WHT ID 3/8-INCH-30M† FFFS WHT ID 3/8-INCH (10/BAG-6IN)†	Fiberglass braid, silicone rubber coating, white, 3/8" diameter, -55 to +200 °C, NEMA TF-1	Expandable silicone coated fiberglass sleeving for protection of cable and coupling nut.	"Heat shrink" -like fit with abrasion, moisture, cut-through, chemical and weld slag resistance.
FFFS WHT ID 5/8-INCH-30M† FFFS WHT ID 5/8-INCH (10/BAG-6IN)†	Fiberglass braid, silicone rubber coating, white, 5/8" diameter, -55 to +200 °C, NEMA TF-1		
FFFS BLK ID 3/4-INCH-30M† FFFS BLK ID 3/4-INCH (10/BAG-6IN)†	Fiberglass braid, silicone rubber coating, black, 3/4" diameter, -55 to +200 °C, NEMA TF-1		
FFFS BLK ID 1-INCH-30M† FFFS BLK ID 1-INCH (10/BAG-6IN)†	Fiberglass braid, silicone rubber coating, black, 1" diameter, -55 to +200 °C, NEMA TF-1		

† Sleeving part numbers only; cordset not included.

Silicone Tubing (*Bulk)



Part Number	Specifications	Application	Features
ST ID 1/4-INCH-30M† ST ID 1/4-INCH (10/BAG-6IN)†	Silicone rubber tubing, translucent, 1/4" diameter, UL	Protective tubing for insulation of cable.	Excellent weld slag resistance.
ST ID 3/8-INCH-30M† ST ID 3/8-INCH (10/BAG-6IN)†	Silicone rubber tubing, translucent, 3/8" diameter, UL		
ST ID 3/8-INCH-30M† ST ID 3/8-INCH (10/BAG-6IN)†	Silicone rubber tubing, translucent, 1/2" diameter, UL		
ST ID 3/4-INCH-30M† ST ID 3/4-INCH (10/BAG-6IN)†	Silicone rubber tubing, translucent, 3/4" diameter, UL		

Add "/S1077" to end of part number to get silicone tubing assembled to pigtail or extension cordsets, up to 4 meters (Picofast, Eurofast, Microfast and Minifast; 0.5 meter min. on extensions).

† Sleeving part numbers only; cordset not included.

Connectivity Accessories

Weld Shield Sleeve - Hook and Loop Closure



We reserve the right to make technical alterations without prior notice.

Part Number	Specifications	Application	Features
FFW 1INC 2FOOT	Plain weave fiberglass, neoprene coated, black, 1" Bundle OD, 3.25" circumference, 4" Sleeve Width Flat, Tested to ISO 6945, -40 to +204 °C Temperature Resistance	Applicable sleeve for protection of cable.	Sleeve offers excellent resistance to abrasion, water, most chemicals, heat, sparks, and flame in a wide operating temperature range, while being lightweight, tough, and highly flexible.
FFW 2INC 2FOOT	Plain weave fiberglass, neoprene coated, black, 2" Bundle OD, 6" circumference, 7.75" Sleeve Width Flat, Tested to ISO 6945, -40 to +204 °C Temperature Resistance		
FFW 3INC 2FOOT*	Plain weave fiberglass, neoprene coated, black, 3" Bundle OD, 9.4" circumference, 11" Sleeve Width Flat, Tested to ISO 6945, -40 to +204 °C Temperature Resistance		
FFW 4INC 2FOOT*	Plain weave fiberglass, neoprene coated, black, 4" Bundle OD, 12.5" circumference, 14" Sleeve Width Flat, Tested to ISO 6945, -40 to +204 °C Temperature Resistance		
FFW 5INC 2FOOT	Plain weave fiberglass, neoprene coated, black, 5" Bundle OD, 15.75" circumference, 17.25" Sleeve Width Flat, Tested to ISO 6945, -40 to +204 °C Temperature Resistance		
FFW 6INC 2FOOT	Plain weave fiberglass, neoprene coated, black, 6" Bundle OD, 18.8" circumference, 20.375" Sleeve Width Flat, Tested to ISO 6945, -40 to +204 °C Temperature Resistance		
FFW 7INC 2FOOT	Plain weave fiberglass, neoprene coated, black, 7" Bundle OD, 22" circumference, 23.5" Sleeve Width Flat, Tested to ISO 6945, -40 to +204 °C Temperature Resistance		
FFW 8INC 2FOOT	Plain weave fiberglass, neoprene coated, black, 8" Bundle OD, 25.125" circumference, 26.625" Sleeve Width Flat, Tested to ISO 6945, -40 to +204 °C Temperature Resistance		

* 25 foot spool also available.

Weld Seal Tape



Part Number	Specifications	Application	Features
FST 1IN 12YARDS	Silicone rubber, Clear, 1" width, 12 yard length, -40 to +204 °C	Applicable clear tape protecting open areas between silicone tubing and mold.	Tape offers excellent resistance to water, most chemicals, heat, sparks, and flame in a wide operating temperature range, while being lightweight and highly flexible.

Connectivity

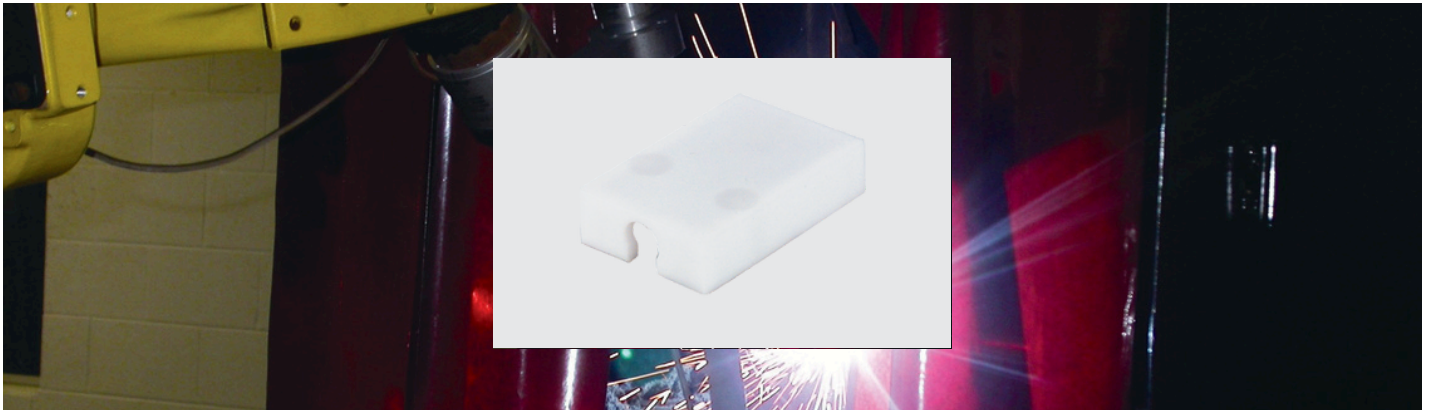

Accessories

A variety of accessories are available to help protect sensors from weld spatter and physical damage.

- Cushion mount accessory protects sensor when used as an end stop
- PTFE and ceramic caps protect the sensor face from weld spatter
- Armorguard sleeves
- Protective cable sleeving
- PTFE coated quick mount allow for quick change mounting

■ Protects against:



Impact



MIG/TIG Weld



Resistance Welding

We reserve the right to make technical alterations without prior notice.

Accessories

	Die Protector	Whisker Probe	Quick Mount	Cushion Mount	Mounting Brackets
Pages	110	110	111	111	112

	Mounting Clamps	PTFE/Ceramic Caps	Protective Covers	Lockwashers and Locknuts	Armorguard Sleeves
Pages	114	115	116	117	118

Accessories

Die Protector

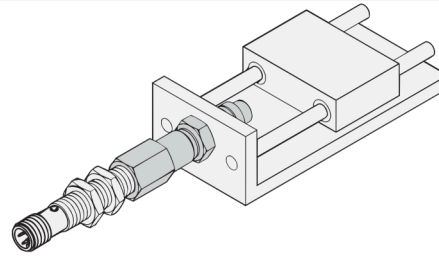
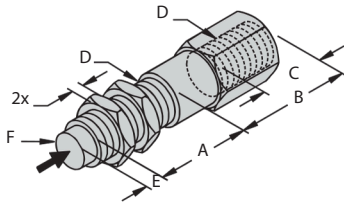

Part Number	ID Number	A	B	C	D	E	F
DP-08-25-08	A2521	0.98 [25.0]	1.25 [31.8]	0.66 [16.7]	M8x1	0.17 [4.3]	0.44 [11.1]
DP-08-50-08	A9473	1.97 [50.0]	1.25 [31.8]	0.66 [16.7]	M8x1	0.17 [4.3]	0.44 [11.1]
DP-12-25-12	A2519	0.98 [25.0]	1.25 [31.8]	0.66 [16.7]	M12x1	0.17 [4.3]	0.62 [15.7]
DP-12-50-12	A9169	1.97 [50.0]	1.25 [31.8]	0.66 [16.7]	M12x1	0.17 [4.3]	0.62 [15.7]
DP-18-25-18	A2520	0.98 [25.0]	1.25 [31.8]	0.66 [16.7]	M18x1	0.17 [4.3]	0.87 [22.1]
DP-18-75-18	A9527	2.95 [75.0]	1.25 [31.8]	0.66 [16.7]	M18x1	0.17 [4.3]	0.87 [22.1]

Inches [mm]

Spring rate for plunger actuation: 9 oz

Recommended Sensors for Die Protector

Die Protector	DP-08-25-08	DP-12-25-12	DP-18-25-18
Sensors	Bi5-U-G08-AP6X Bi2-G08-AP6X	Bi2-G12-AP6X-H1141	Bi5-G18-AP6X (When not fully engaged)

Note: Works with all shielded NPN, PNP, quick disconnect or potted-in-cable versions of the listed part numbers.

Whisker Probe

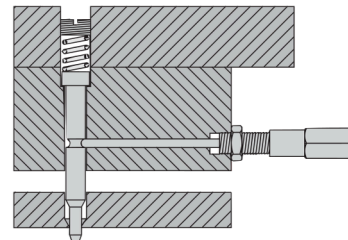
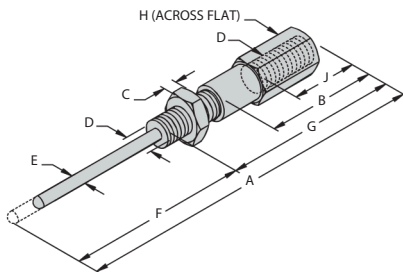

Part Number	ID Number	A	B	C	D	E	F	G	H	J
WP-08-50-03	A2527	3.92 [99.6]	1.25 [31.8]	0.15 [3.8]	M8x1	0.13 [3.2]	2.00 [50.8]	1.95 [49.5]	0.44 [11.1]	0.86 [21.8]
WP-12-50-03	A2528	3.92 [99.6]	1.25 [31.8]	0.15 [3.8]	M12x1	0.13 [3.2]	2.00 [50.8]	1.95 [49.5]	0.44 [11.1]	0.86 [21.8]
WP-12-50-06	A2529	3.92 [99.6]	1.25 [31.8]	0.15 [3.8]	M12x1	0.25 [6.4]	2.00 [50.8]	1.95 [49.5]	0.62 [15.8]	0.71 [18.0]
WP-12-100-06	A9195	5.91 [150]	1.25 [31.8]	0.15 [3.8]	M12x1	0.25 [6.4]	4.00 [102]	1.95 [49.5]	0.62 [15.8]	0.71 [18.0]

Inches [mm]

Recommended Sensors for Whisker Probe

Whisker Probe	WP-08-50-03	WP-12-50-03	WP-12-50-06
Sensors	Bi1-G08-AN6 Bi1.5-G08-AP6X	Bi1.5U-EG08-AP6X Bi2-EG08-AP6X	Bi2-G12-AP6X-H1141 Bi3U-M12-AP6X-H1141

Note: Works with all shielded NPN, PNP, quick disconnect or potted-in-cable versions of the listed part numbers. Not for use with Uprox3.

We reserve the right to make technical alterations without prior notice.

We reserve the right to make technical alterations without prior notice.

Accessories

Quick Mount

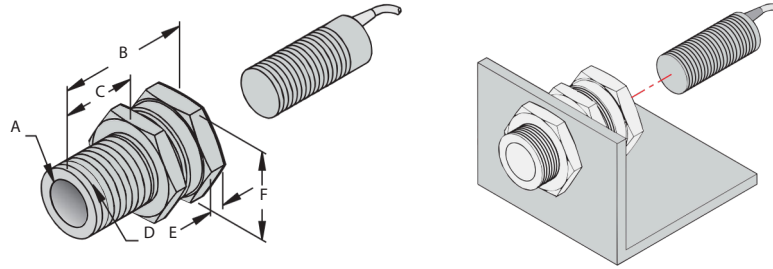

Part Number	ID Number	Features	A	B	C	D	E	F
QM-08	A2511	—	0.32 [8.18]	1.28 [32.4]	0.69 [17.5]	M12x1	0.15 [3.85]	0.67 [16.9]
QM-08L	A2512	Ext. Length	0.32 [8.18]	1.90 [48.0]	1.34 [34.0]	M12x1	0.15 [3.85]	0.67 [16.9]
QM-12	A2513	—	0.48 [12.1]	1.34 [33.7]	0.77 [19.5]	M16x1	0.16 [4.01]	0.86 [21.8]
QM-12L	A2514	Ext. Length	0.48 [12.1]	1.76 [44.8]	1.18 [30.0]	M16x1	0.16 [4.01]	0.86 [21.8]
QM-12L-T	A2542	Ext. Length, PTFE	0.48 [12.1]	1.76 [44.8]	1.18 [30.0]	M16x1	0.16 [4.01]	0.86 [21.8]
QM-18	A2515	—	0.71 [18.1]	1.52 [38.5]	0.79 [20.0]	M24x1.5	0.19 [4.95]	1.18 [30.0]
QM-18L	A2516	Ext. Length	0.71 [18.1]	2.28 [58.0]	1.57 [40.0]	M24x1.5	0.19 [4.95]	1.18 [30.0]
QM-18L-T	A2543	Ext. Length, PTFE	1.19 [30.1]	2.28 [58.0]	1.57 [40.0]	M24x1.5	0.24 [6.13]	1.61 [41.0]
QM-30	A2517	—	1.19 [30.1]	1.50 [35.0]	0.79 [20.0]	M36x1.5	0.24 [6.13]	1.61 [41.0]
QM-30L	A2518	Ext. Length	1.19 [30.1]	2.28 [58.0]	1.57 [40.0]	M36x1.5	0.24 [6.13]	1.61 [41.0]

Inches [mm]
Material: Nickel plated brass

Cushion Mount

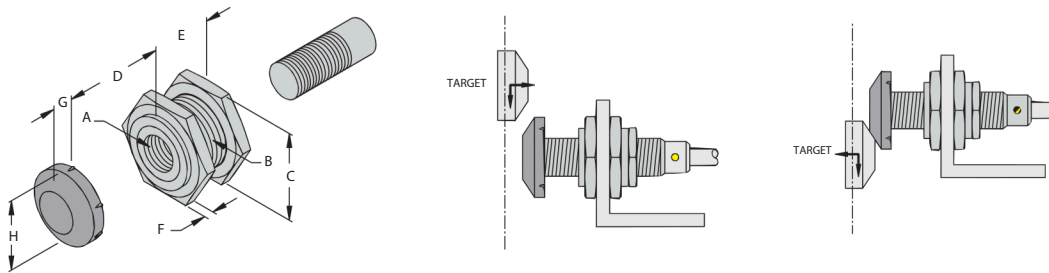

Part Number	ID Number	A	B	C	D	E	F	G	H	Cap Part Number	Cap ID Number
		Inside Thread	Outside Thread	Across Flats	Max Allowable O ver travel						
CM-08	A2503	M8x1	M16x1.5	0.88 [22.2]	0.35 [8.89]	0.87 [22.1]	0.16 [3.94]	0.21 [5.33]	0.60 [15.2]	CAP-EN08	A6100
CM-08N	A2504									CAP-EN08N	A6200
CM-12	A2505	M12x1	M22x1.5	1.12 [28.6]	0.40 [10.0]	0.87 [22.1]	0.16 [4.06]	0.245 [6.22]	0.90 [22.9]	CAP-EN12	A6300
CM-12N	A2506									CAP-EN12N	A6300-1
CM-18	A2507	M18x1	M30x1.5	1.41 [35.8]	0.49 [12.4]	1.17 [29.7]	0.20 [5.10]	0.33 [8.38]	1.18 [30.0]	CAP-EN18	A6400
CM-18N	A2508									CAP-EN18N	A6400-1
CM-30	A2509	M30x1.5	M47x1.5	2.01 [51.0]	0.57 [14.5]	1.47 [37.3]	0.20 [5.10]	0.30 [7.62]	1.72 [43.7]	CAP-EN30	A 9567
CM-30N	A2510									—	—

Inches [mm]
Material: Anodized aluminum
Cap: Plastic
Stainless versions available (CM-**N*SS)

We reserve the right to make technical alterations without prior notice.

Accessories

Accessories

Mounting Brackets

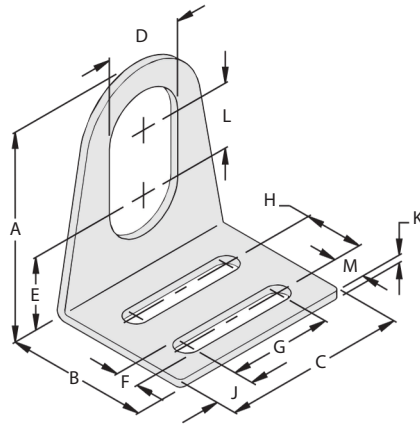

Part Number	ID Number	Barrel Diameter	A	B	C	D	E	F	G	H	J	K	L	M
MBSS-08	A2522	8 mm	1.00 [25.4]	1.13 [28.7]	1.25 [31.8]	0.34 [8.74]	0.31 [7.92]	0.22 [5.54]	0.63 [15.9]	0.47 [11.9]	0.31 [7.92]	0.070 [1.78]	0.37 [9.53]	0.28 [7.14]
MBSS-12	A2523	12 mm	1.50 [38.1]	1.37 [34.8]	1.50 [38.1]	0.50 [12.7]	0.55 [13.9]	0.22 [5.54]	0.75 [19.1]	0.56 [14.3]	0.37 [9.53]	0.070 [1.78]	0.50 [12.7]	0.31 [7.92]
MBSS-18	A2524	18 mm	2.00 [50.8]	1.37 [34.8]	1.75 [44.5]	0.75 [19.1]	0.22 [5.54]	0.22 [5.54]	1.00 [25.4]	0.56 [14.3]	0.37 [9.53]	0.070 [1.78]	0.62 [15.9]	0.31 [7.92]
MBSS-30	A2525	30 mm	2.50 [63.5]	1.75 [44.5]	2.25 [57.2]	1.18 [30.5]	0.91 [23.0]	0.22 [5.54]	1.37 [34.8]	0.81 [20.6]	0.44 [11.2]	0.085 [2.16]	0.75 [19.1]	0.41 [10.3]

Inches [mm]
Material: 304 stainless steel

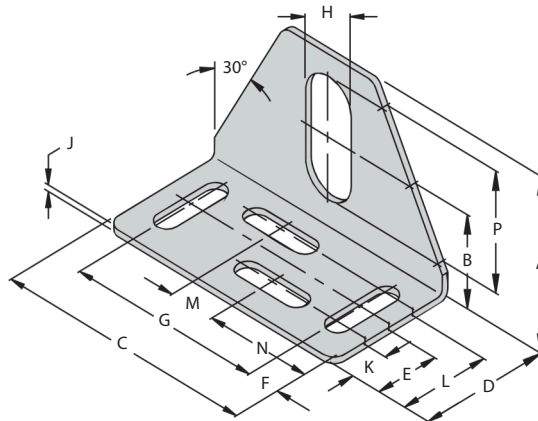

Part Number	ID Number	Barrel Diameter	A	B	C	D	E	F	G	H	J	K	L	M	N	P
MB-8	A3130-1	8 mm	1.26 [32.0]	0.66 [16.7]	2.00 [50.8]	1.00 [25.4]	0.45 [11.5]	0.30 [7.5]	1.41 [35.8]	0.33 [8.4]	0.06 [1.5]	0.24 [6.0]	0.67 [17.0]	0.35 [8.8]	0.83 [21.0]	.84 [21.4]
MB-12	A3130	12 mm	1.63 [41.5]	0.87 [22.15]	2.50 [63.5]	1.25 [31.8]	0.61 [15.5]	0.31 [7.9]	1.88 [47.8]	0.50 [12.7]	0.06 [1.5]	0.35 [9.0]	0.87 [22.0]	0.45 [11.5]	1.02 [26.0]	1.13 [28.7]
MB-18	A3135	18 mm	1.63 [41.5]	0.79 [20.0]	2.50 [63.5]	1.25 [31.8]	0.61 [15.5]	0.31 [7.9]	1.88 [47.8]	0.75 [19.1]	0.06 [1.5]	0.35 [9.0]	0.87 [22.0]	0.45 [11.5]	1.04 [26.3]	1.15 [29.1]
MB-30	A3140	30 mm	2.62 [66.5]	1.32 [33.5]	4.25 [108.0]	1.75 [44.5]	0.88 [22.4]	0.37 [9.5]	3.50 [88.9]	1.19 [30.2]	0.07 [1.8]	0.63 [16.0]	1.14 [29.0]	1.18 [30.0]	1.54 [39.0]	2.06 [52.2]

Inches [mm]
Material: Cold roll steel
Finish: Galvanized

We reserve the right to make technical alterations without prior notice.

Accessories

Mounting Brackets

MW-Q4.7/5.5

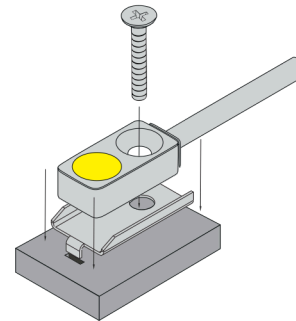
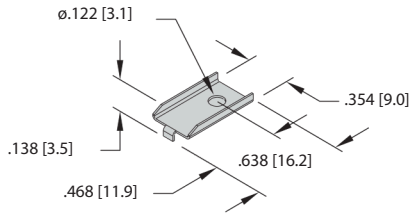

Part Number	ID Number
MW-Q4.7/5.5	6945013

Inches [mm]
 Material: Stainless steel
 *For surface mounting of Q4.7 or Q5.5 sensors

MB - Q50/CK40

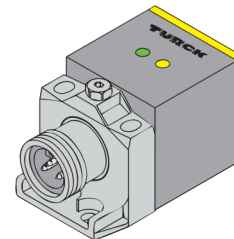
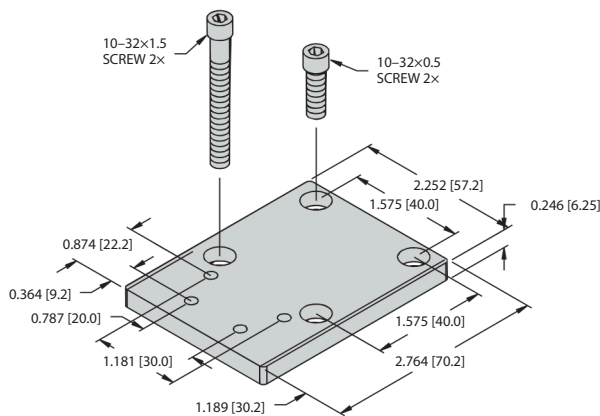

Part Number	ID Number
MB-Q50/CK40	A3148

Inches [mm]
 Material: Stainless steel
 *For use with Q50 or CK40 sensors

SG-UNT

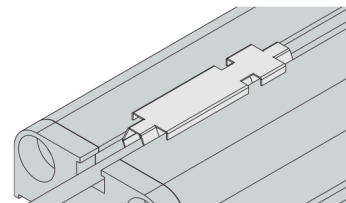
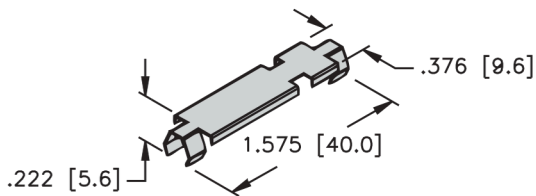

Part Number	ID Number
SG-UNT	A9800

Inches [mm]
 Material: Nickel-plated steel
 *For use with BIM-UNT cylinder sensors

We reserve the right to make technical alterations without prior notice.

Accessories

Accessories

Mounting Clamps

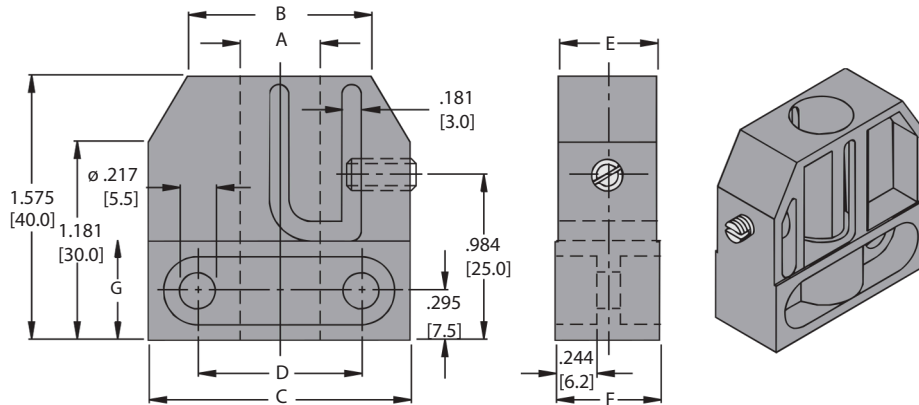

Part Number	ID Number	Barrel Diameter	A	B	C	D	E	F	G
BS-12	M6947000	12 mm	0.48 [12.2]	1.10 [28.0]	1.57 [40.0]	0.98 [25.0]	0.59 [15.0]	0.63 [16.0]	0.59 [15.0]
BS-18	M6947100	18 mm	0.72 [18.2]	1.30 [33.0]	1.77 [45.0]	1.18 [30.0]	0.83 [21.0]	0.87 [22.0]	0.59 [15.0]

Inches [mm]

Material: PA 66-GF

*For use with 12 and 18 mm threaded barrel sensors

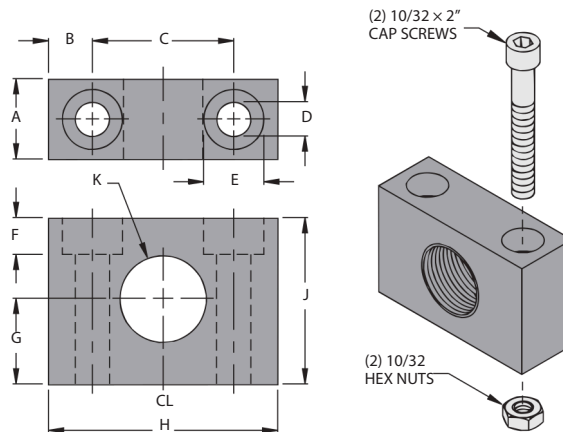

Part Number	ID Number	Barrel Diameter	A	B	C	D	E	F	G	H	J	K
MB-S12	A3150	12 mm	0.44 [11.2]	0.24 [6.2]	0.77 [19.6]	0.20 [5.0]	0.34 [8.7]	0.20 [5.0]	0.45 [11.4]	1.26 [32.0]	0.91 [23.0]	M12x1
MB-S18	A3155	18 mm	0.63 [16.0]	0.30 [7.6]	1.20 [30.5]	0.22 [5.5]	0.38 [9.6]	0.25 [6.4]	0.57 [14.5]	1.80 [45.8]	1.15 [29.3]	M18x1

Inches [mm]

Material: Delrin

*For use with 12 and 18 mm threaded barrel sensors. Mounting hardware included.

We reserve the right to make technical alterations without prior notice.

Accessories

PTFE / Ceramic Caps

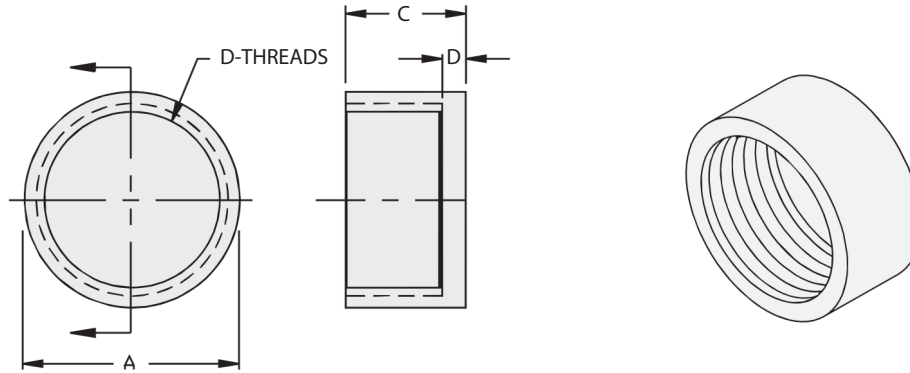

We reserve the right to make technical alterations without prior notice.

Part Number	ID Number	Barrel Diameter	Material	A	B	C	D
CAP 08-PTFE	A3055-1	8 mm Embeddable	PTFE	0.375 [9.5]	0.03 [0.7]	0.437 [11.1]	M8x1
CAP 08-DER	A9326	8 mm Embeddable	Delrin	0.375 [9.53]	0.03 [0.76]	0.437 [11.1]	M8x1
CAP 12-PTFE	M6966200	12 mm Embeddable	PTFE	0.63 [16.0]	0.03 [0.7]	0.63 [16.0]	M12x1
CAP 12-CER	A2530	12 mm Embeddable	Ceramic	0.58 [14.7]	0.035 [.89]	0.35 [8.90]	M12x1
CAP 12-DER	A9321	12 mm Embeddable	Delrin	0.58 [14.7]	0.035 [.89]	0.35 [8.90]	M12x1
CAP 12N-CER	A9129	12 mm Non-embeddable	Ceramic	0.58 [14.7]	0.035 [.89]	0.60 [15.2]	M12x1
CAP 12N-DER	A9322	12 mm Non-embeddable	Delrin	0.58 [14.7]	0.035 [.89]	0.60 [15.2]	M12x1
CAP 18-PTFE	A3055	18 mm Embeddable	PTFE	0.87 [22.0]	0.04 [1.0]	0.35 [9.0]	M18x1
CAP 18N-PTFE	A3056	18 mm Non-embeddable	PTFE	0.87 [22.0]	0.04 [1.0]	0.35 [9.0]	M18x1
CAP 18-CER	A2531	18 mm Embeddable	Ceramic	0.95 [24.1]	0.045 [1.14]	0.35 [8.90]	M18x1
CAP 18-DER	A9323	18 mm Embeddable	Delrin	0.95 [24.1]	0.045 [1.14]	0.35 [8.90]	M18x1
CAP 18N-CER	A3056-4	18 mm Non-embeddable	Ceramic	0.95 [24.1]	0.045 [1.14]	0.70 [17.8]	M18x1
CAP 18N-DER	A9324	18 mm Non-embeddable	Delrin	0.95 [24.1]	0.045 [1.14]	0.70 [17.8]	M18x1
CAP 30-PTFE	A3057	30 mm Embeddable	PTFE	1.34 [34.0]	0.05 [1.2]	0.35 [9.0]	M30x1.5
CAP 30N-PTFE	A3058	30 mm Non-embeddable	PTFE	1.34 [34.0]	0.05 [1.2]	1.14 [29.0]	M30x1.5
CAP 30-CER	A2532	30 mm Embeddable	Ceramic	1.50 [38.1]	0.08 [2.03]	0.39 [9.90]	M30x1.5
CAP 30-DER	A9325	30 mm Embeddable	Delrin	1.50 [38.1]	0.08 [2.03]	0.39 [9.90]	M30x1.5
CAP 30N-DER	A9320	30 mm Non-embeddable	Delrin	1.50 [38.1]	0.08 [2.03]	1.00 [25.4]	M30x1.5
CAP 47-PTFE	A3060	47 mm Embeddable	Delrin	2.20 [55.8]	0.06 [1.6]	0.38 [9.7]	M30x1.5
CAP 47-PTFE	A3060		PTFE				PG 36

Inches [mm]

Accessories

Accessories

Protective Covers

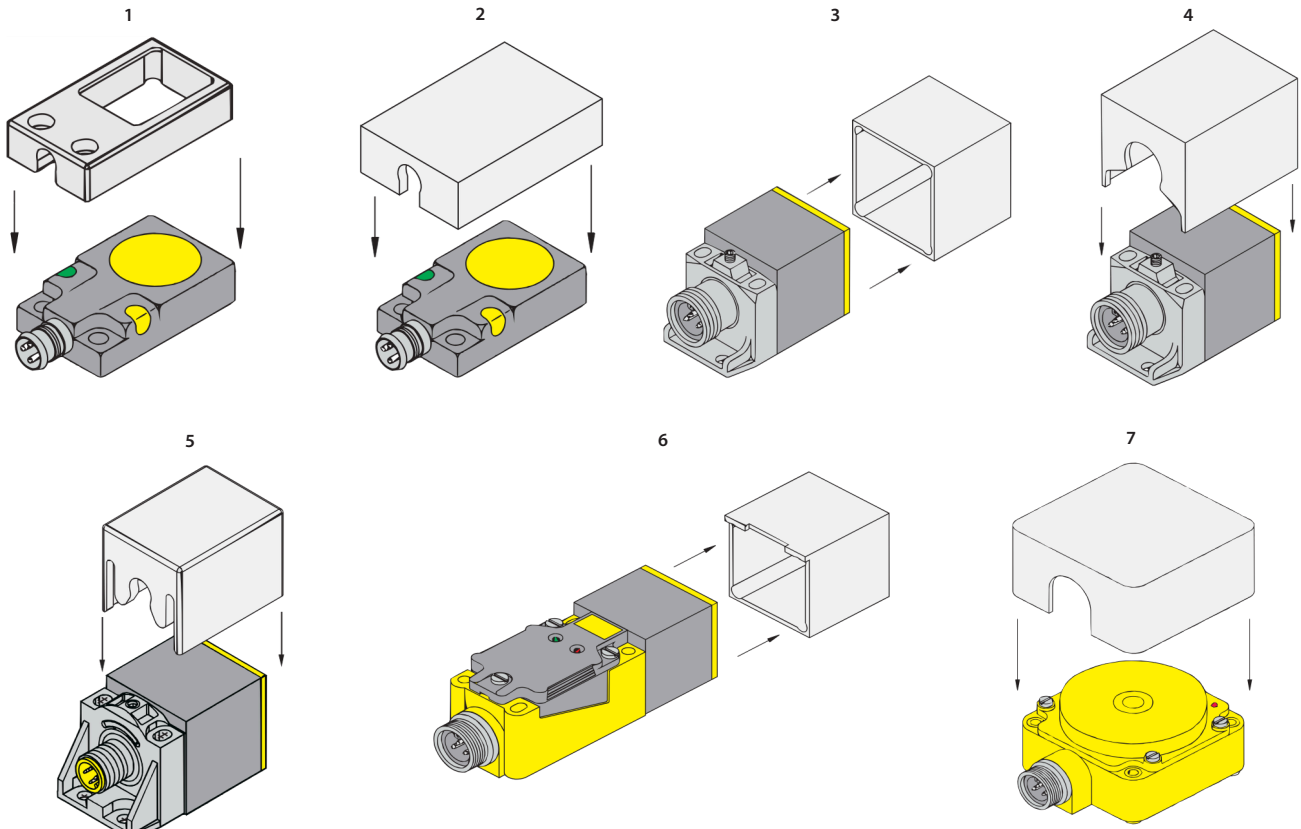

Part Number	ID Number	Material	For Use With Sensor Housing	Drawing Image
MBS - Q08TS	A9492	Nickel Plated Steel	Q08	1
T-Q08-T-MCC	A5155	PTFE	Q08	2
T-Q14-T-MCC	A5154	PTFE	Q14	2
T-Q20-T-MCC	A5156	PTFE	Q20	2
T-CK40-T-FC	A5202	PTFE	CK40	3
T-CK40-D-FC	A5160	Delrin	CK40	3
T-CK40-T-MCC	A5201	PTFE	CK40	4
T-CK40-T-MCB	A9126	PTFE	CK40	5
T-CP40-T-C	A5204	PTFE	CP40	6
T-CP80-T	A5207	PTFE	CP80	7

We reserve the right to make technical alterations without prior notice.

Accessories

Locknuts and Washers

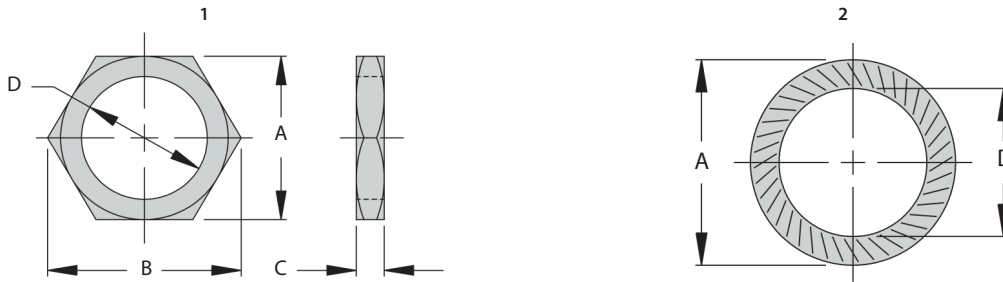

Part Number	ID Number	Barrel Diameter	Materials	A	B	C	D	Dimension Drawing
Locknut-SS08	A3123-08	8 mm	SS	0.51 [13.0]	0.58 [14.7]	0.16 [4.0]	M8x1	1
Locknut-M8X1PTFE	A9696	8 mm	PTFE	0.51 [13.0]	0.58 [14.7]	0.16 [4.0]	M8x1	1
Locknut-M12	A3122	12 mm	CPB	0.67 [17.0]	0.76 [19.4]	0.16 [4.0]	M12x1	1
Locknut-MT12	A3109	12 mm	PTFE	0.67 [17.0]	0.76 [19.4]	0.16 [4.0]	M12x1	1
Locknut-SS12	A3123	12 mm	SS	0.67 [17.0]	0.76 [19.4]	0.16 [4.0]	M12x1	1
Locknut-M18	A3125	18 mm	CPB	0.94 [24.0]	1.08 [27.4]	0.16 [4.0]	M18x1	1
Locknut-MT18	A3108	18 mm	PTFE	0.94 [24.0]	1.08 [27.4]	0.16 [4.0]	M18x1	1
Locknut-SS18	A3123-0	18 mm	SS	0.94 [24.0]	1.08 [27.4]	0.16 [4.0]	M18x1	1
Locknut-M30	A3126	30 mm	CPB	1.42 [36.0]	1.63 [41.4]	0.20 [5.0]	M30x1.5	1
Locknut-MT30	A3107	30 mm	PTFE	1.42 [36.0]	1.63 [41.4]	0.20 [5.0]	M30x1.5	1
Locknut-SS30	A3123-1	30 mm	SS	1.42 [36.0]	1.63 [41.4]	0.20 [5.0]	M30x1.5	1
LW-08	A3124	8 mm	SS	0.55 [14] 0.70 [17.8]	N/A	N/A	0.32 [8.2]	2
LW-12	A3127	12 mm	SS	1.06 [26.8]	N/A	N/A	0.52 [13.2]	2
LW-18	A3128	18 mm	SS	1.76 [44.8]	N/A	N/A	0.76 [19.3]	2
LW-30	A3129	30 mm	SS		N/A	N/A	1.26 [32.0]	2

Inches [mm]

*For use with threaded barrel sensors

We reserve the right to make technical alterations without prior notice.

Accessories

Accessories

Mounting Clamps

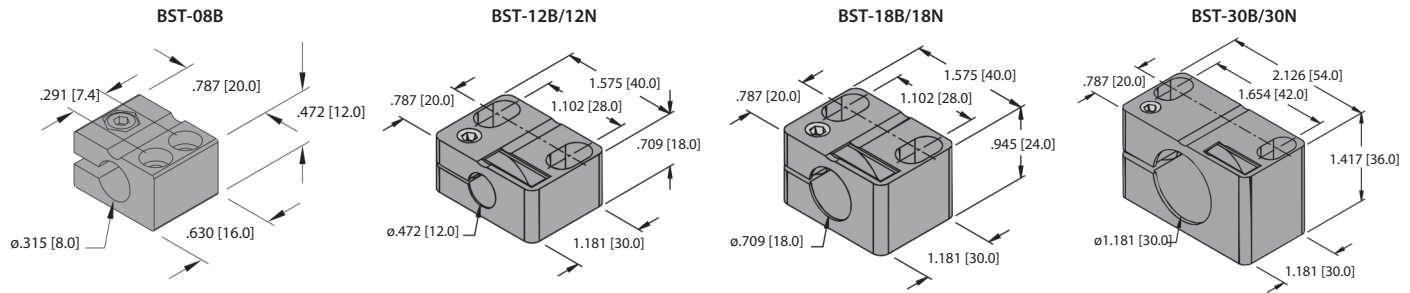

Part Number	ID Number	Barrel Diameter
BST-08B	6947210	8 mm
BST-12B	6947212	12 mm
BST-12N	6945200	12 mm
BS-18B	6947214	18 mm
BST-18N	6947215	18 mm
BST-30B	6947216	30 mm
BST-30N	6947217	30 mm

Inches [mm]

B Version comes with dead stop for flush mounted sensors

Material: PA 66-6F

*For use with threaded barrel sensors

Armorguard Sleeves

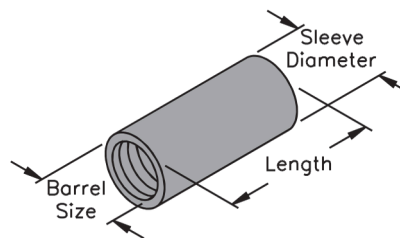

Part Number	ID Number	Barrel Size	Sleeve Diameter	Length
MBS-08TS 7MM	A0835	M8x1	Ø0.48 [12.1]	0.28 [7.0]
MBS-08TS 15MM	A0835-01			0.59 [15.0]
MBS-12TS 15MM	A3152-04	M12x1	Ø0.61 [15.6]	0.59 [15.0]
MBS-12TS 35MM	A3152-01			1.38 [35.0]
MBS-12TS 45MM	A3152-02			1.77 [45.0]
MBS-12TS 50MM	A3152-03			1.97 [50.0]
MBS-18TS 7MM	A0837	M18x1	Ø0.85 [21.5]	0.28 [7.0]
MBS-18TS 15MM	A3143-03			0.59 [15.0]
MBS-18TS 35MM	A3143-01			1.38 [35.0]
MBS-18TS 45MM	A3143-02			1.77 [45.0]
MBS-18TS 50MM	A3143			1.97 [50.0]
MBS-30TS 7MM	A9123	M30x1	Ø1.32 [33.6]	0.28 [7.0]
MBS-30TS 15MM	A9124			0.59 [15.0]

Inches [mm]

*For use with threaded barrel sensors

Pressure Sensor Accessories

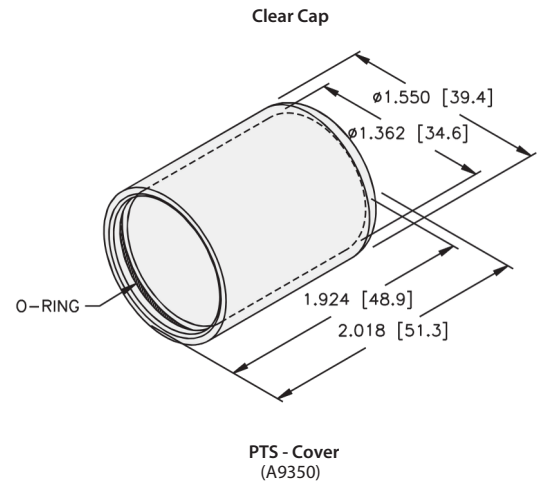

We reserve the right to make technical alterations without prior notice.



Accessories

Notes

A large, empty grid area for taking notes, consisting of a 30x30 grid of small squares.

Index

B

Bi1.5-EG08-AD6X-H1341/S1589	27	Bi1.5-EG08F-AG6X	61	Bi1.5-EG08F-AG6X-0.3-RS4.23T	61	Bi1.5-EG08F-AN6X	65	Bi1.5-EG08F-AN6X-H1341	65	Bi1.5-EG08F-AP6X	65	Bi1.5-EG08F-AP6X-H1341	65	Bi1.5-EGT08F-AG6X	61	Bi1.5-EGT08F-AG6X-0.2-RS4.23T	61	Bi1.5U-EG08-AP6X-H1341/S1589	21	Bi2-EG08-AG41X-0.2-RS4.23T/S1589	27	Bi2-EG08-AG41X-H1341/S1589	27	Bi2-EG08-AG41X/S1589	27	Bi2-EG08-AN6X-H1341/S1589	21	Bi2-EG08-AN6X-V1131/S1589	23	Bi2-EG08-AP6X-0.2-RS4T/S1589	25	Bi2-EG08-AP6X-H1341/S1589	21	Bi2-EG08-AP6X/S1589	25	Bi2-EG08-AP6X/S1610	55	Bi2-EG08-AP6X-V1131/S1589	23	Bi2-EG08F-AG6X	61	Bi2-EG08K-AG41X-0.3-RS4.23T/S1589	27	Bi2-EG08K-AG41X-H1341/S1589	27	Bi2-EG08K-AN6X-H1341/S1589	21	Bi2-EG08K-AP6X-0.2-RS4T/S1589	25	Bi2-EG08K-AP6X-H1341/S1589	21	Bi2-EG08K-AP6X-V1131/S1589	23	Bi2-EG12F-AG6X	61	Bi2-EG12F-AG6X-0.3-RS4.23T	61	Bi2-EG12F-AN6X	67	Bi2-EG12F-AN6X-H1141	67	Bi2-EG12F-AP6X	67	Bi2-EG12F-AP6X-H1141	67	Bi2-EG12K-AP6X-0.2-RS4T/S1589	31	Bi2-EGT08-AG41X-0.2-RS4.23T/S1589	27	Bi2-EGT08-AP6X-H1341/S100/S1589	21	Bi2-EGT08K-AG41X-H1341/S1589	27	Bi2-EGT08K-AP6X-0.5-RS4T/S100/S1765	25	Bi2-EGT12F-AG6X	61	Bi2-EGT12F-AG6X-H1141	61	Bi2-EGT12F-AP6X-H1141	67	Bi2-GT12-ADZ32X-B3131/S34/S1589	37	Bi2-GT12-ADZ32X-B3131/S34	79	Bi2-Q4.7-AP6X-0.2-PSG3M/S1154	15	Bi2-Q4.7-AP6X-0.3-PSG3M/S1589	15	Bi2-Q4.7-AP6X-0.3-RS4T/S1154	15	Bi2-Q4.7-AP6X-0.3-RS4T/S1589	15	Bi2-Q4.7-AP6X-0.5-PSG3M/S1154	15	Bi2-Q4.7-AP6X-0.5-RS4T/S1154	15	Bi2-Q5.5-AN6X-0.5-PSG3M/S1764	15	Bi2-Q5.5-AP6X-0.2-PSG3M/S1154	15	Bi2-Q5.5-AP6X-0.2-RS4T/S34/S1764	15	Bi2-Q5.5-AP6X-0.4-RS4T/S34/S1764	15	Bi2-Q5.5-AP6X-0.5-RS4T/S1764	15	Bi2U-EG08-EG08-AP6X-0.2-RS4T/S1589	25	Bi2U-EG08-AP6X-H1341/S1589	21	Bi2U-EGT08-AP6X-H1341/S1589	21	Bi2U-EGT08-AP6X-V1131/S1589	23	Bi3-EG08FE-AN6X	65	Bi3-EG08FE-AN6X-H1341	65	Bi3-EG08FE-AP6X	65	Bi3-EG08FE-AP6X-H1341	65	Bi3-EG08FE-AP6X-H1341/S1589	21	Bi3-EG12F-AG6X	61	Bi3-EGT08FE-AP6X	61	Bi3-EGT08FE-AP6X-0.2-RS4T/S1154	25	Bi3-EGT08FE-AP6X-H1341	65	Bi3-EGT08FE-AP6X-H1341/S1589	21	Bi3-GT12K-AD4X/S1610	55	Bi3-MT12-AD4X-0.3-RS4.23T/S1589	33	Bi3-MT12-AD4X-H1141/S1589	33	Bi3-MT12-AD4X-H1144/S1589	33	Bi3-MT12E-AD4X-H1141/S1589	33	Bi3-MT12E-AD4X-H1144/S1589	33	Bi3-MT12H-AD4X-H1144	73	Bi3-MT12HE-AD4X-H1141	73	Bi3U-EM12E-AN6X2-H1141/S1589	31	Bi3U-EM12H-AP6X-H1141	73	Bi3U-EM12HE-AN6X2-H1141	73	Bi3U-EM12HE-AP6X2-H1141	73	Bi3U-EM12HE-AP6X2-H1141/S1589	31	Bi3U-EMT08-AP6X-H1341/S1589	21	Bi3U-EMT08-AP6X-V1131/S1589	23	Bi3U-MT12-AP6X2-H1141/S1589	31	Bi3U-MT12-AP6X-H1141/S1589	31	Bi3U-MT12E-AN6X2-H1141/S1589	31	Bi3U-MT12E-AP6X2-H1141/S1589	31	Bi3U-MT12E-AP6X2-H1141/S1610	55	Bi3U-MT12H-AP6X-H1141	73	Bi3U-MT12HE-AN6X2-H1141	73	Bi3U-MT12HE-AP6X2-H1141	73	Bi4-EM12E-AN6X-H1141/S1589	31	Bi4-EM12E-AP6X-H1141/S1589	31	Bi4-GT12-ADZ32X-B3131/S1589	37	Bi4-GT12H-ADZ32X-B3131	79	Bi4-MT12-AN6X-H1141/S1589	31	Bi4-MT12-AP6X-H1141/S1589	31	Bi4-MT12E-AN6X-H1141/S1589	31	Bi4-MT12E-AP6X-H1141/S1589	31	Bi4-MT12H-AN6X-H1141	73	Bi4-MT12H-AP6X-H1141	73	Bi4-MT12HE-AN6X-H1141	73	Bi4U-EM12-AP6X-H1141/S1589	31	Bi4U-MT12-AP6X-H1141/S1589	31	Bi4U-MT12-AP6X-H1141/S1610	55	Bi4U-MT12E-AP6X2-H1141/S1589	31	Bi5-EG18F-AG6X	63	Bi5-EG18F-AG6X-0.3-RS4.23T	63	Bi5-EG18F-AG6X-H1141	63	Bi5-EG18F-AN6X	69	Bi5-EG18F-AN6X-H1141	69	Bi5-EG18F-AP6X-H1141	69	Bi5-EGT18F-AG6X	63	Bi5-EGT18F-AN6X-H1141	69	Bi5-EM18H-AP6X-H1141	75	Bi5-GT18-ADZ30X2-B1331/S34/S1589	45	Bi5-GT18-ADZ30X2-B1431/S34/S1589	45	Bi5-GT18-ADZ30X2-B3331/S34/S1589	45	Bi5-GT18H-ADZ30X2-B1331/S34	79	Bi5-GT18H-ADZ30X2-B3331/S34	79	Bi5U-EM18H-AP6X2-H1141/S395/S1589	39	Bi5U-EM18H-AP6X2-H1141/S395/S1610	57	Bi5U-EM18H-AN6X2-H1141/S395	75	Bi5U-EM18H-AP6X2-H1141/S395	75	Bi5U-EM18H-AP6X2-H1141/S395/S1589	39	Bi5U-EM18H-AP6X2-H1141/S395/S1610	57	Bi5U-MT18-AP6X2-H1141/S1589	39	Bi5U-MT18-AP6X2-H1141/S1589	39	Bi5U-MT18H-AP6X2-H1141/S395	75	Bi5U-Q08-AP6X2-0.2-RS4T/S1589	17	Bi5U-Q08-AP6X2-0.3-RS4T/S1154	17	Bi6-EG12FE-AN6X	67	Bi6-EG12FE-AN6X-H1141	67	Bi6-EG12FE-AP6X	67	Bi6-EG12FE-AP6X-H1141	67	Bi6-EGT12FE-AN6X-H1141	67	Bi6-EGT12FE-AP6X-0.3-RS4T/S1589	31	Bi6-EGT12FE-AP6X-H1141	67	Bi6-EGT12FE-AP6X-H1141/S1589	31	Bi7-EG18F-AG6X	63	Bi7-EM18HE-AD4X-H1141	75	Bi7-GT18K-AD4X-0.2-RS4.23T/S1589	41	Bi7-MT18-AD4X-H1144/S1589	41	Bi7-MT18E-AD4X-0.3-RS4.23T/S1589	41	Bi7-MT18E-AD4X-H1141/S1589	41	Bi7-MT18E-AD4X-H1144/S1589	41	Bi7-MT18H-AD4X-H1141	75	Bi7-MT18HE-AD4X-H1141	75	Bi7-Q08-AP6X2-0.2-PSG3M/S1154	17	Bi7-Q08-AP6X2-0.3-RS4T/S1589	17	Bi7-Q08-AP6X2-0.3-RSE 4T-P7X2/S1589	17	Bi7-Q08-AP6X2-0.5-PSG3M/S1765	17	Bi7-Q08-AP6X2-0.5-RS4T/S1154	17	Bi7-Q08-AP6X2-0.5-RS4T/S1764	17	Bi7-Q08-AP6X2-0.5-RS4T/S1765	17	Bi7-Q08F-AN6X	65
---------------------------------------	----	----------------------------	----	--	----	----------------------------	----	----------------------------------	----	----------------------------	----	----------------------------------	----	-----------------------------	----	---	----	--	----	--	----	--------------------------------------	----	--------------------------------	----	-------------------------------------	----	-------------------------------------	----	--	----	-------------------------------------	----	-------------------------------	----	-------------------------------	----	-------------------------------------	----	--------------------------	----	---	----	---------------------------------------	----	--------------------------------------	----	---	----	--------------------------------------	----	--------------------------------------	----	--------------------------	----	--------------------------------------	----	--------------------------	----	--------------------------------	----	--------------------------	----	--------------------------------	----	---	----	---	----	---	----	--	----	---	----	---------------------------	----	---------------------------------	----	---------------------------------	----	---	----	-------------------------------------	----	---	----	---	----	--	----	--	----	---	----	--	----	---	----	---	----	--	----	--	----	--	----	--	----	--------------------------------------	----	---------------------------------------	----	---------------------------------------	----	---------------------------	----	---------------------------------	----	---------------------------	----	---------------------------------	----	---------------------------------------	----	--------------------------	----	----------------------------	----	---	----	----------------------------------	----	--	----	--------------------------------	----	---	----	-------------------------------------	----	-------------------------------------	----	--------------------------------------	----	--------------------------------------	----	--------------------------------	----	---------------------------------	----	--	----	---------------------------------	----	-----------------------------------	----	-----------------------------------	----	---	----	---------------------------------------	----	---------------------------------------	----	---------------------------------------	----	--------------------------------------	----	--	----	--	----	--	----	---------------------------------	----	-----------------------------------	----	-----------------------------------	----	--------------------------------------	----	--------------------------------------	----	---------------------------------------	----	----------------------------------	----	-------------------------------------	----	-------------------------------------	----	--------------------------------------	----	--------------------------------------	----	--------------------------------	----	--------------------------------	----	---------------------------------	----	--------------------------------------	----	--------------------------------------	----	--------------------------------------	----	--	----	--------------------------	----	--------------------------------------	----	--------------------------------	----	--------------------------	----	--------------------------------	----	--------------------------------	----	---------------------------	----	---------------------------------	----	--------------------------------	----	--	----	--	----	--	----	---------------------------------------	----	---------------------------------------	----	---	----	---	----	---------------------------------------	----	---------------------------------------	----	---	----	---	----	---------------------------------------	----	---------------------------------------	----	---------------------------------------	----	---	----	---	----	---------------------------	----	---------------------------------	----	---------------------------	----	---------------------------------	----	----------------------------------	----	---	----	----------------------------------	----	--	----	--------------------------	----	---------------------------------	----	--	----	-------------------------------------	----	--	----	--------------------------------------	----	--------------------------------------	----	--------------------------------	----	---------------------------------	----	---	----	--	----	---	----	---	----	--	----	--	----	--	----	-------------------------	----

We reserve the right to make technical alterations without prior notice.

Index

Locknut-M30 117
 Locknut-MT12..... 117
 Locknut-MT18..... 117
 Locknut-MT30..... 117
 Locknut-SS08 117
 Locknut-SS12 117
 Locknut-SS18..... 117
 Locknut-SS30..... 117
 LW-08..... 117
 LW-12..... 117
 LW-18..... 117
 LW-30..... 117

M

MB-8..... 112
 MB-12..... 112
 MB-18..... 112
 MB-30..... 112
 MB-Q4.7/5.5..... 113
 MB-Q50/CK40..... 113
 MBS-08TS 7MM..... 118
 MBS-08TS 15MM..... 118
 MB-S12 114
 MBS-12TS 15MM..... 118
 MBS-12TS 35MM..... 118
 MBS-12TS 45MM..... 118
 MBS-12TS 50MM..... 118
 MB-S18 114
 MBS-18TS 7MM..... 118
 MBS-18TS 15MM..... 118
 MBS-18TS 35MM..... 118
 MBS-18TS 45MM..... 118
 MBS-18TS 50MM..... 118
 MBS-30TS 7MM..... 118
 MBS-30TS 15MM..... 118
 MBS-Q08TS..... 116
 MBSS-08..... 112
 MBSS-12..... 112
 MBSS-18..... 112
 MBSS-30..... 112

N

NI3-EG08-AP6X-H1141/S1589..... 29
 NI4-EG08-AG41X-H1141/S1589..... 29
 NI4-GT12-ADZ32X-B3131/S34/S1589..... 37
 NI4U-EG08-AP6X-H1141/S1589..... 29
 NI6U-EG08-AN6X-H1141/S1589..... 29
 NI6U-EGT08-AP6X-H1141/S1589..... 29
 NI8-EM12E-AP6X-H1141/S1589..... 35
 NI8-GT12-ADZ32X-B3131/S1589..... 37
 NI8-GT18-ADZ30X2-B1331/S34/S1589..... 45
 NI8-GT18-ADZ30X2-B3331/S34/S1589..... 45
 NI8-MT12-AD4X-H1141/S1589..... 35
 NI8-MT12E-AN6X-H1141/S1589..... 35
 NI8-MT12E-AP6X-H1141/S1589..... 35
 NI8U-EM12E-AN6X2-H1141/S1589..... 35
 NI8U-EM12E-AP6X2-H1141/S1589..... 35

NI8U-MT12-AP6X2-H1141/S1589..... 35
 NI8U-MT12E-AN6X2-H1141/S1589..... 35
 NI8U-MT12E-AP6X2-H1141/S1589..... 35
 NI10U-MT12-AP6X-H1141/S1589..... 35
 NI10U-MT12E-AP6X2-H1141/S1589..... 35
 NI12U-EM18-AN6X2-H1141/S395/S1589..... 43
 NI12U-EM18-AP6X2-H1141/S395/S1589..... 43
 NI12U-MT18-AP6X2-H1141/S395/S1589..... 43
 NI12U-MT18-AP6X2-H1141/S1589..... 43
 NI14-EM18E-AP6X-H1141/S1589..... 43
 NI14-GT18-ADZ30X2-B1331/S1589..... 45
 NI14-GT18-ADZ30X2-B3331/S1589..... 45
 NI14-MT18E-AP6X-H1141/S1589..... 43
 NI15U-MT18-AN6X-H1141/S1589..... 43
 NI15U-MT18-AP6X-H1141/S1589..... 43
 NI15U-MT18M-AP6X2-H1141/S1589..... 43
 NI20-MT30-AN6X-H1141/S1589..... 47
 NI20U-EM30-AN6X2-H1141/S1589..... 47
 NI20U-EM30-AP6X2-H1141/S1589..... 47
 NI20U-MT30-AP6X2-H1141/S1589..... 47
 NI25U-CK40-AP6X2-H1141/S1590 W/BS 2.1..... 19
 NI30U-MT30-AP6X2-H1141/S1589..... 47
 NI35U-CK40-AP6X2-H1141/S1590 W/BS 4..... 19
 NI50U-CK40-AP6X2-H1141/S1590 W/BS 4..... 19
 NIMFE-EM12/4.0L61-UN6X-0.3XYE-RS4/S1182..... 83
 NIMFE-EM12/4.0L61-UN6X-H1141/S1182..... 83
 NIMFE-EM12/4.0L61-UP6X-0.3XYE-RS4/S1182..... 83
 NIMFE-EM12/4.0L61-UP6X-H1141/S1182..... 83
 NIMFE-EM12/4.6L88-UN6X-H1141/S1182..... 83
 NIMFE-EM12/4.6L88-UP6X-H1141/S1182..... 83
 NIMFE-EM12/4.9L88-UP6X-H1141/S1182..... 83
 NIMFE-EM12/6.2L101-UP6X-H1141/S1182..... 83
 NIMFE-EMT12/4.6L88-UN6X-H1141..... 83
 NIMFE-EMT12/4.6L88-UP6X-H1141..... 83
 NIMFE-EMT12/6.2L101-UN6X-H1141..... 83
 NIMFE-EMT12/6.2L101-UP6X-H1141..... 83
 NIMFE-M12/4.6L88-UN6X-H1141..... 83
 NIMFE-M12/4.6L88-UP6X-H1141..... 83
 NIMFE-M12/6.2L101-UN6X-H1141..... 83
 NIMFE-M12/6.2L101-UP6X-H1141..... 83

P

PKG 3M-*.97
 PKG 3M-*/S90/S101..... 97
 PKG 3M-*/S90/S618..... 97
 PKG 3M-*/S90/S1084..... 97
 PKG 3M-*/S760..... 97
 PKW 3M-*.97
 PKW 3M-*/S90/S101..... 97
 PKW 3M-*/S90/S618..... 97
 PKW 3M-*/S90/S1084..... 97
 PKW 3M-*/S760..... 97

PS0.25V-503-2UPNX-H1141..... 89
 PS0.25V-503-LI2UPN8X-H1141..... 89
 PS001R-303-2UPNX-H1141..... 91
 PS001R-303-LI2UPN8X-H1141..... 91
 PS001R-503-2UPNX-H1141..... 89
 PS001R-503-LI2UPN8X-H1141..... 89
 PS001V-303-2UPNX-H1141..... 91
 PS001V-303-LI2UPN8X-H1141..... 91
 PS001V-503-2UPNX-H1141..... 89
 PS001V-503-LI2UPN8X-H1141..... 89
 PS01VR-303-2UPNX-H1141..... 91
 PS01VR-303-LI2UPN8X-H1141..... 91
 PS01VR-503-2UPNX-H1141..... 89
 PS01VR-503-LI2UPN8X-H1141..... 89
 PS003V-303-2UPNX-H1141..... 91
 PS003V-303-LI2UPN8X-H1141..... 91
 PS003V-503-2UPNX-H1141..... 89
 PS003V-503-LI2UPN8X-H1141..... 89
 PS010V-303-2UPNX-H1141..... 91
 PS010V-303-LI2UPN8X-H1141..... 91
 PS010V-503-2UPNX-H1141..... 89
 PS010V-503-LI2UPN8X-H1141..... 89
 PS016V-303-2UPNX-H1141..... 91
 PS016V-303-LI2UPN8X-H1141..... 91
 PS016V-503-2UPNX-H1141..... 89
 PS016V-503-LI2UPN8X-H1141..... 89
 PS025R-303-LI2UPN8X-H1141..... 91
 PS025V-303-2UPNX-H1141..... 91
 PS025V-503-2UPNX-H1141..... 89
 PS025V-503-LI2UPN8X-H1141..... 89
 PS040R-303-LI2UPN8X-H1141..... 91
 PS040V-303-2UPNX-H1141..... 91
 PS040V-503-2UPNX-H1141..... 89
 PS040V-503-LI2UPN8X-H1141..... 89
 PS100R-303-2UPNX-H1141..... 91
 PS100R-303-LI2UPN8X-H1141..... 91
 PS100R-503-2UPNX-H1141..... 89
 PS100R-503-LI2UPN8X-H1141..... 89
 PS250R-303-2UPNX-H1141..... 91
 PS250R-303-LI2UPN8X-H1141..... 91
 PS250R-503-2UPNX-H1141..... 89
 PS250R-503-LI2UPN8X-H1141..... 89
 PS400R-303-2UPNX-H1141..... 91
 PS400R-303-LI2UPN8X-H1141..... 91
 PS400R-503-2UPNX-H1141..... 89
 PS400R-503-LI2UPN8X-H1141..... 89
 PS600R-303-2UPNX-H1141..... 91
 PS600R-303-LI2UPN8X-H1141..... 91
 PS600R-503-2UPNX-H1141..... 89
 PS600R-503-LI2UPN8X-H1141..... 89
 PSG 3M-*.97
 PSG 3M-*/S90..... 97
 PSG 3M-*/S90/S101..... 97
 PSG 3M-*/S90/S618..... 97

We reserve the right to make technical alterations without prior notice.

Index

PSG 3M-*/S90/S1084 97
 PSG 3M-*/S760 97
 PSG 3M-*/S1587 97
 PSW 3M-*/S90 97
 PSW 3M-*/S90/S101 97
 PSW 3M-*/S90/S618 97
 PSW 3M-*/S90/S1084 97
 PSW 3M-*/S760 97
 PSW 3M-*/S1587 97

Q

QM-08 111
 QM-08L 111
 QM-12 111
 QM-12L 111
 QM-12L-T 111
 QM-18 111
 QM-18L 111
 QM-18L-T 111
 QM-30 111
 QM-30L 111

R

RK 4.2T-* 98
 RK 4.2T-*/S90 98
 RK 4.2T-*/S748 98
 RK 4.4T-*/S3415 100
 RK 4.2T-* 98
 RK 4.23T-* 101, 102
 RK 4.41T-* 101, 102
 RK 4T-* 99, 100
 RK 4T-*/S90 99, 100
 RK 4T-*/S529 99
 RK 4T-*/S618 99
 RK 4T-*/S715 99
 RK 4T-*/S760 99
 RK 4T-*/S3415 99
 RKC 4.4T-*/S1587 101
 RKE 4.4T-*/S849/S1587/PNP-NPN 102
 RKG 4-*/S600 101
 RKM 4T-* 104
 RKM 30-*M 104
 RKM 30-*M/S90 104
 RKM 30-*M/S101 104
 RKM 31-*M 104
 RKM 31-*M/S600 104
 RKM 311-*M 104
 RKM 311-*M/S600 104
 RS 4.2T-* 98
 RS 4.2T-*/S90 98
 RS 4.2T-*/S748 98
 RS 4.4T-*/S3415 100
 RS 4.22T-* 98
 RS 4.23T-* 98

RS 4.41T-* 101
 RS 4.41T-*/S529 101
 RS 4T-* 99, 100
 RS 4T-*/S90 99, 100
 RS 4T-*/S101 99, 100
 RS 4T-*/S529 99
 RS 4T-*/S618 99
 RS 4T-*/S715 99
 RS 4T-*/S760 99
 RS 4T-*/S3415 99
 RSC 4.4T-*/S1587 101
 RSG 4T-* 101
 RSG 4T-*/S600 101
 RSM 30-*M 104
 RSM 30-*M/S90 104
 RSM 30-*M/S101 104
 RSM 31-*M 104
 RSM 31-*M/S600 104
 RSM 311-*M 104
 RSM 311-*M/S600 104

S

SB 3T-* 103
 SB 3T-*/S90 103
 SB 3T-*/S105 103
 SB 3T-*/S749 103
 SB 3T-*/S1507 103
 SG-UNT 113
 ST ID 1/4-INCH (10/BAG-6IN) 106
 ST ID 1/4-INCH-30M 106
 ST ID 3/4-INCH (10/BAG-6IN) 106
 ST ID 3/4-INCH-30M 106
 ST ID 3/8-INCH (10/BAG-6IN) 106
 ST ID 3/8-INCH-30M 106

T

T-CK40-D-FC 116
 T-CK40-T-FC 116
 T-CK40-T-MCB 116
 T-CK40-T-MCC 116
 T-CP40-T-C 116
 T-CP80-T 116
 T-Q08-T-MCC 116
 T-Q14-T-MCC 116
 T-Q20-T-MCC 116

V

VBRS 4.4-2RK 4T-*/S3415 100

W

WK 4.2T-* 98
 WK 4.2T-*/S90 98
 WK 4.2T-*/S748 98
 WK 4.4T-*/S3415 100
 WK 4.22T-* 98
 WK 4.23T-* 98
 WK 4.41T-* 101, 102
 WK 4.41T-*/S529 101, 102

WK 4T-* 99, 100
 WK 4T-*/S90 99, 100
 WK 4T-*/S101 99, 100
 WK 4T-*/S529 99
 WK 4T-*/S618 99
 WK 4T-*/S715 99
 WK 4T-*/S760 99
 WK 4T-*/S3415 103
 WKB 3T-* 103
 WKB 3T-*/S90 103
 WKB 3T-*/S749 103
 WKB 3T-*/S1507 103
 WKC 4.4T-*/S849/S1587/PNP-NPN 102
 WKC 4.4T-*/S1587 101
 WKM 30-*M 104
 WKM 30-*M/S90 104
 WKM 30-*M/S101 104
 WKM 31-*M 104
 WKM 31-*M/S600 104
 WKM 311-*M 104
 WKM 311-*M/S600 104
 WP-08-50-03 110
 WP-12-50-03 110
 WP-12-50-06 110
 WS 4.2T-* 98
 WS 4.2T-*/S90 98
 WS 4.4T-*/S3415 100
 WS 4.22T-* 98
 WS 4.23T-* 101
 WS 4.41T-*/S529 101
 WS 4T-* 99, 100
 WS 4T-*/S90 99, 100
 WS 4T-*/S101 99, 100
 WS 4T-*/S529 99
 WS 4T-*/S618 99
 WS 4T-*/S715 99
 WS 4T-*/S760 99
 WS 4T-*/S3415 99
 WSB 3T-* 103
 WSB 3T-*/S90 103
 WSB 3T-*/S105 103
 WSB 3T-*/S749 103
 WSB 3T-*/S1507 103
 WSM 30-*M 104
 WSM 30-*M/S90 104
 WSM 30-*M/S101 104
 WSM 31-*M 104
 WSM 31-*M/S600 104
 WSM 311-*M 104
 WSM 311-*M/S600 104

We reserve the right to make technical alterations without prior notice.

Turck Inc. sells its products through authorized distributors. These distributors provide our customers with technical support, service and local stock. Turck distributors are located nationwide – including all major metropolitan marketing areas.

For application assistance or for the location of your nearest Turck distributor, call:

1-800-544-7769

Specifications in this manual are subject to change with out notice. Turck also reserves the right to make modifications and makes no guarantee of the accuracy of the information contained herein.

Literature and media questions or concerns?
Contact Turck USA Marketing – info@turck.com



TURCK

Apodaca N.L.

Av Kalos 119, Kalos, 66603 Cd Apodaca, N.L.
Contacto (81) 8386-1707 / (81) 8386-9195 /
(81) 8386-9197 / (81) 8386-5563

Piedras Negras, Coahuila

Lib. Manuel Pérez Treviño 2413, Río Escondido,
26080 Piedras Negras, Coah.
Contacto
(87) 8795-2108

Acuña, Coahuila

Heroes de Nacozari No. 604, Local 4 Col. Benito
Juarez, Cd. Acuña Coahuila
Contacto (877) 772-1396



28 subsidiaries and over
60 representations worldwide!

Printed in USA