

2.9L 6-CYL

1994 Volvo 960

ENGINES
2.9L 6-Cylinder

960

NOTE: For repair procedures not covered in this article, see the ENGINE OVERHAUL PROCEDURES - GENERAL INFORMATION article in the GENERAL INFORMATION section.

ENGINE IDENTIFICATION

Engine may be identified by using Vehicle Identification Number (VIN) stamped on a metal pad, located near lower left corner of windshield. The sixth and seventh character identifies engine model.

Engine identification number, located on left side of cylinder block below cylinder head, may be required when ordering replacement parts.

ENGINE IDENTIFICATION CODES

Engine	Type	Code
2.9L (960)	B6304S	98

ADJUSTMENTS

VALVE CLEARANCE ADJUSTMENT

Engine is equipped with hydraulic lifters. No valve adjustment is necessary.

REMOVAL & INSTALLATION

NOTE: For reassembly reference, label all electrical connectors, vacuum hoses and fuel lines before removal. Also place mating marks on other major assemblies before removal. Hood removal is not necessary, as hood opens to horizontal position. Removal and installation information for turbocharger is not available from manufacturer.

FUEL PRESSURE RELEASE

Fuel Pump Pressure Release

Before disconnecting any lines, cover fuel line connector with shop towel to absorb any fuel left in line. With ignition key removed from ignition switch, reconnect relay.

ENGINE

Removal

1) Place hood in vertical position. Disconnect battery. Remove ground lead connection to body at top side member. Remove clip on side member. Remove battery. Remove auxiliary drive belt. Remove cooling fan and drain coolant.

2) Disconnect upper and lower coolant hoses from engine. Disconnect expansion tank hose from radiator and return pipe.

Disconnect cooling lines from radiator.

3) Remove top nut from both left and right engine mounts. Remove air mass meter and intake hose. Disconnect and remove large and small crankcase ventilation hoses, idling hose and idling valve lead.

4) Remove 2 EVAP valve hoses at intake manifold. Remove air mass meter connector, air preheater hose and throttle pulley cover. Remove 3 bolts at front of servo pump and 2 at rear of servo pump. Remove servo pump.

5) Disconnect fuel return line at regulator. Remove fuel line at bulkhead. Remove throttle cable. Remove cruise control vacuum hose. Remove fuel line snap catches. Remove engine wiring harness cover and disconnect connector. Remove harness duct mounting nuts.

6) Disconnect 2 cooling hoses from firewall. Remove 2 ECC hoses at intake manifold. Remove camshaft sensor, timing pick-up and brake servo vacuum line. To support engine, use 2 Support Rails (5033), Lifting Beam (5006), Lifting Hook (5115) and Lifting Yoke (5428). Attach Lifting Lug (5429) to rear of engine. Support engine.

7) Remove splash guard and air baffle under engine. Loosen 2 radiator mounting bolts. Drain engine oil. Disconnect oil thermostat hoses at thermostat in cylinder block. Remove 2 air conditioner compressor mounting bolts and disconnect electrical connector. Support compressor and lay aside.

8) Loosen exhaust pipe flanges at manifold. Remove lower section of air preheater pipe. Remove exhaust pipe shield. Remove oil cooler lines at transmission. Disconnect gear selector lever from transmission.

9) Disconnect oxygen sensor wiring. Mark propeller shaft for reassembly reference. Disconnect propeller shaft and remove transmission support member. Place jack under transmission and remove all lifting tools. Remove radiator attaching bolts. Lift out radiator and transmission fluid cooling lines.

10) Using Lifting Tool (2810), lift engine from vehicle. Remove jack from under transmission.

Installation

1) Attach Lifting Lug (5429) to rear of engine. Using Lifting Yoke (5428) and Lifting Tool (2810), lower engine and transmission into position. Guide engine mountings into position and tighten top nuts to 37 ft. lbs. (50 N.m).

2) Support transmission with jack and remove lifting yoke from engine. Using 2 Support Rails (5033), Lifting Beam (5006) and Lifting Hook (5115), support rear of engine. Remove jack under transmission. Using Transmission Lifting Fixture (5972), raise transmission. Install transmission support member. Tighten bolted joints between support member and side members. Tighten transmission bump stop nut to 37 ft. lbs. (50 N.m).

3) Install control rod and reaction arm to lever mounting. Install locking clip. Install oxygen sensor and reconnect electrical connector. Using Socket (5244), tighten front and rear couplings. Ensure "O" ring is okay and install air preheater pipe to exhaust pipe.

4) Install air conditioning compressor to mounting. Reconnect oil cooler lines. Tighten fittings to 26 ft. lbs. (35 N.m). Remove lifting tools.

5) Reinstall coolant hoses to firewall. Install timing pick-up and camshaft sensor connectors. Reconnect engine connector to wiring harness connector on left wheel housing. Reconnect relay and install wiring duct mounting nuts. Install harness connector cover.

6) Install fuel hoses, cruise control vacuum hose, ECC vacuum hoses, brake servo vacuum hose, throttle cable and throttle pulley cover. Install air mass meter and intake hose. Reconnect idling valve hose and connector. Reconnect oil trap hoses. Reconnect 2 EVAP vacuum hoses.

7) Install servo pump and drive belt. Install radiator and radiator hoses, expansion tank hoses, and transmission oil cooler lines. Tighten cooling line fittings to 26 ft. lbs. (35 N.m). Install cooling fan. Install battery and reconnect positive cable.

8) Jack up vehicle and reconnect cooling lines to transmission. Tighten fittings to 26 ft. lbs. (35 N.m). Install exhaust pipe and heat shield. Install radiator mounting bolts, air baffle under radiator, and splash guard under engine. Fill engine with oil and cooling system. Connect negative battery cable. Start engine and check for leaks.

INTAKE MANIFOLD

Removal & Installation

For intake manifold removal and installation procedures, see CYLINDER HEAD under REMOVAL & INSTALLATION.

EXHAUST MANIFOLD

Removal (960)

Remove nuts and front exhaust pipe. Remove 12 heat shield retaining bolts. Remove heat shield. Remove exhaust manifolds and gaskets.

Installation

1) Using NEW gaskets, install exhaust manifolds. Using Joint Sealing Compound (1 161 035-9), install and tighten manifold-to-cylinder head nuts to 18 ft. lbs. (25 N.m). Install heat shield and tighten bolts to 11 ft. lbs. (15 N.m).

2) Install front exhaust pipe. Using Joint Sealing Compound (1 161 035-9), install and tighten front exhaust pipe bolts. See TORQUE SPECIFICATIONS. To prevent stress on exhaust system, unbolt joint after catalytic converter and retighten to 18 ft. lbs. (25 N.m).

CYLINDER HEAD

Removal

1) Disconnect negative battery cable and drain coolant. Remove front exhaust pipe, heat shield, exhaust manifolds and gaskets.

2) Remove air mass meter and intake hose. Remove throttle pulley cover. Disconnect throttle switch connector, throttle cable, cruise control vacuum servo, cable bracket at throttle pulley and 2 vacuum hoses at throttle housing. Remove fuel distribution manifold and injectors. Cut and discard clamps securing rubber sleeves between intake manifold sections. Lift out intake manifold.

3) Remove coolant temperature sensor. Disconnect coolant hose from thermostat housing. Mark ignition coils and camshaft pulleys for reassembly reference. Remove ignition coils and pulleys.

4) From rear of engine, remove camshaft position sensor, switch mounting bracket, ground terminals No. 1 and 2, temperature sensor connector and rear coolant hoses. See Fig. 2.

5) Remove top cylinder head bolts. Carefully tap top of cylinder head upward with a copper mallet. Tap joint lugs and camshaft front ends. Remove camshafts. Loosen and remove cylinder heads, starting at outside edge and working inward. Remove cylinder head and head gasket. See Fig. 1.

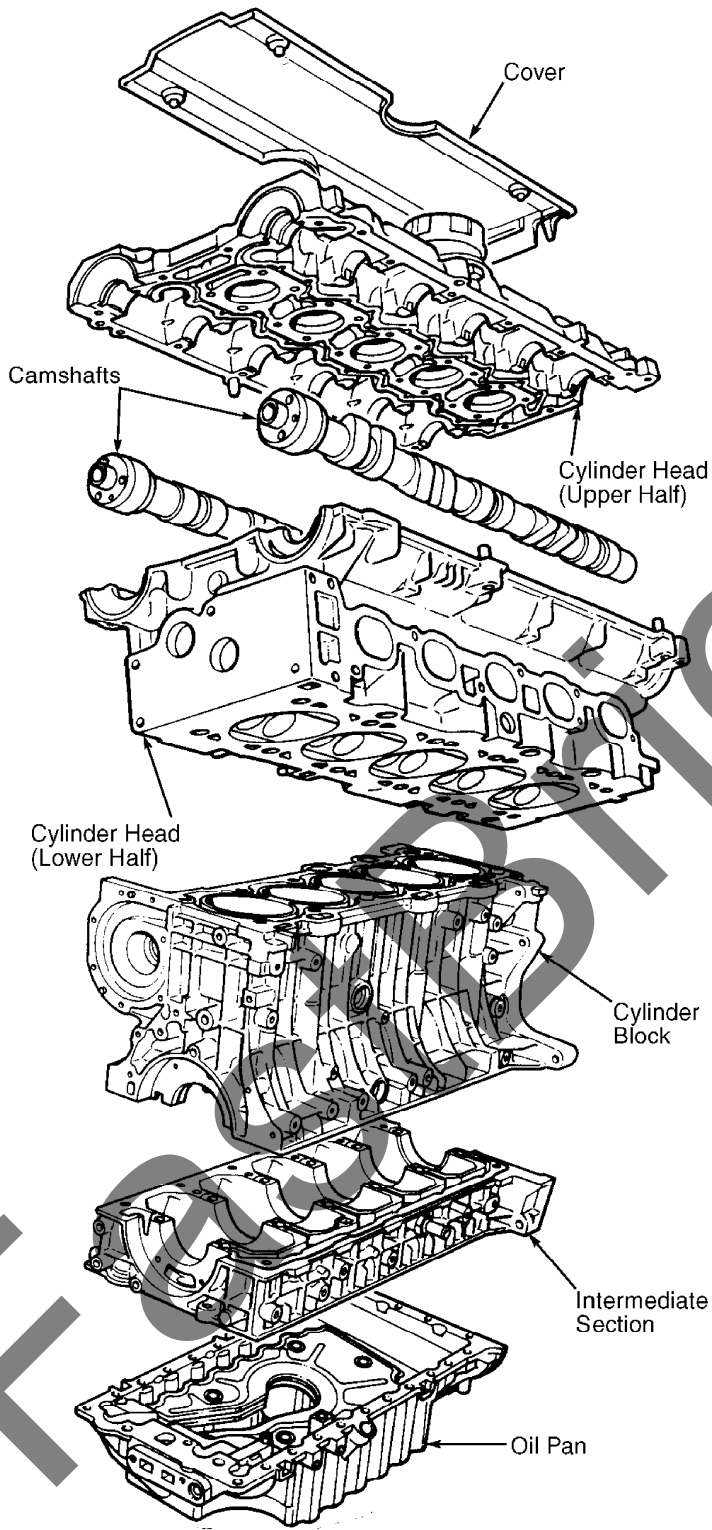

93B83411
Fig. 1: Exploded View Of Engine Assembly
(5-Cylinder Shown; 6-Cylinder is Similar)
Courtesy of Volvo Cars of North America.

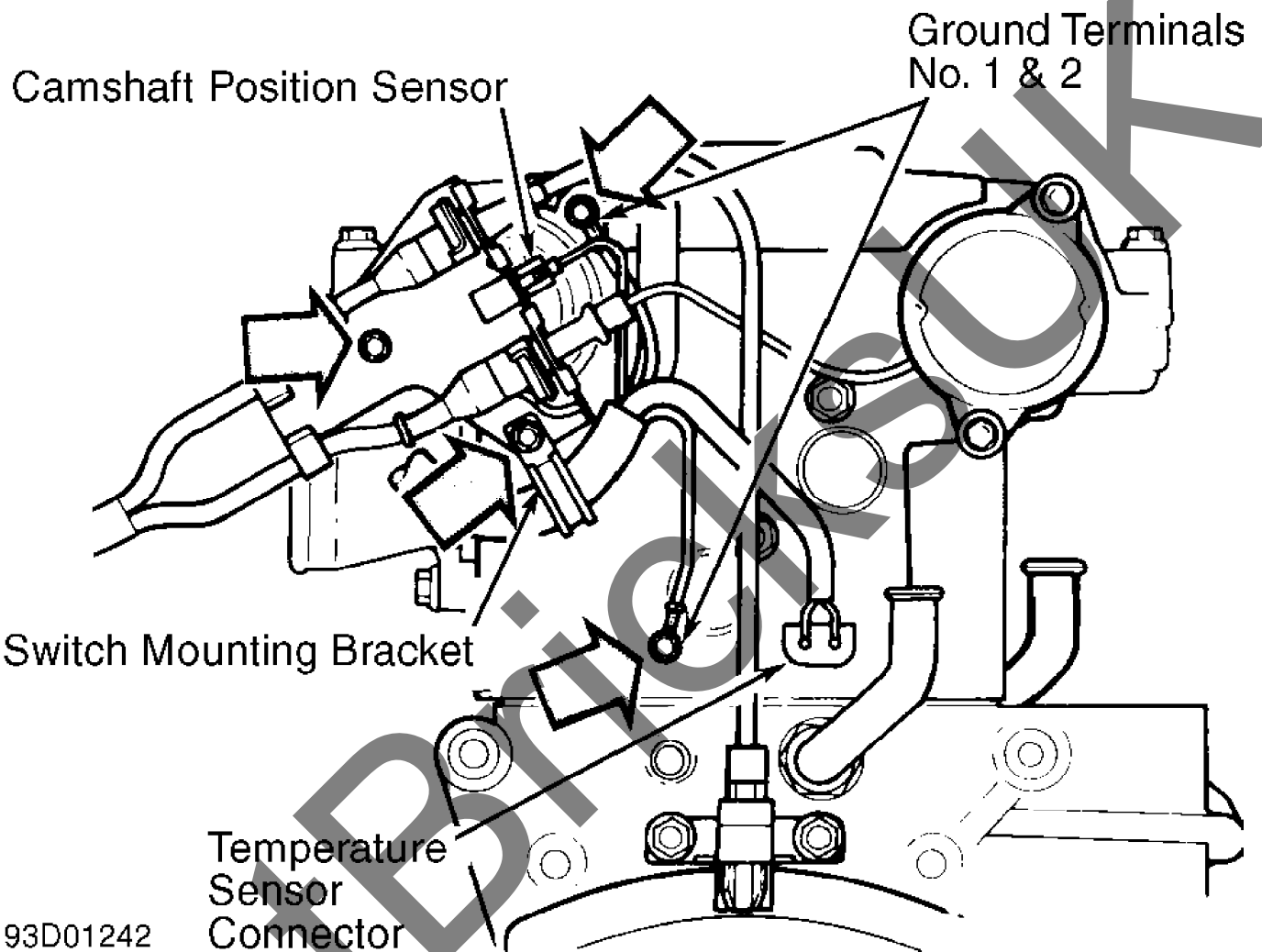

Fig. 2: Removing Components From Rear Of Engine

Installation

1) Remove starter and protective plug. Install Crankshaft Locking Tool (5451). See Fig. 3. Turn crankshaft counterclockwise until stopped by tool. Using NEW gasket, install bottom half of cylinder head. Oil bolts and tighten, in sequence, in 3 steps. See Fig. 4. See TORQUE SPECIFICATIONS.

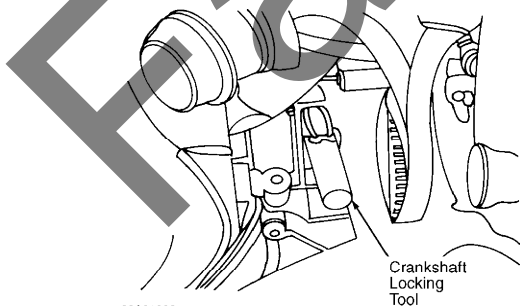
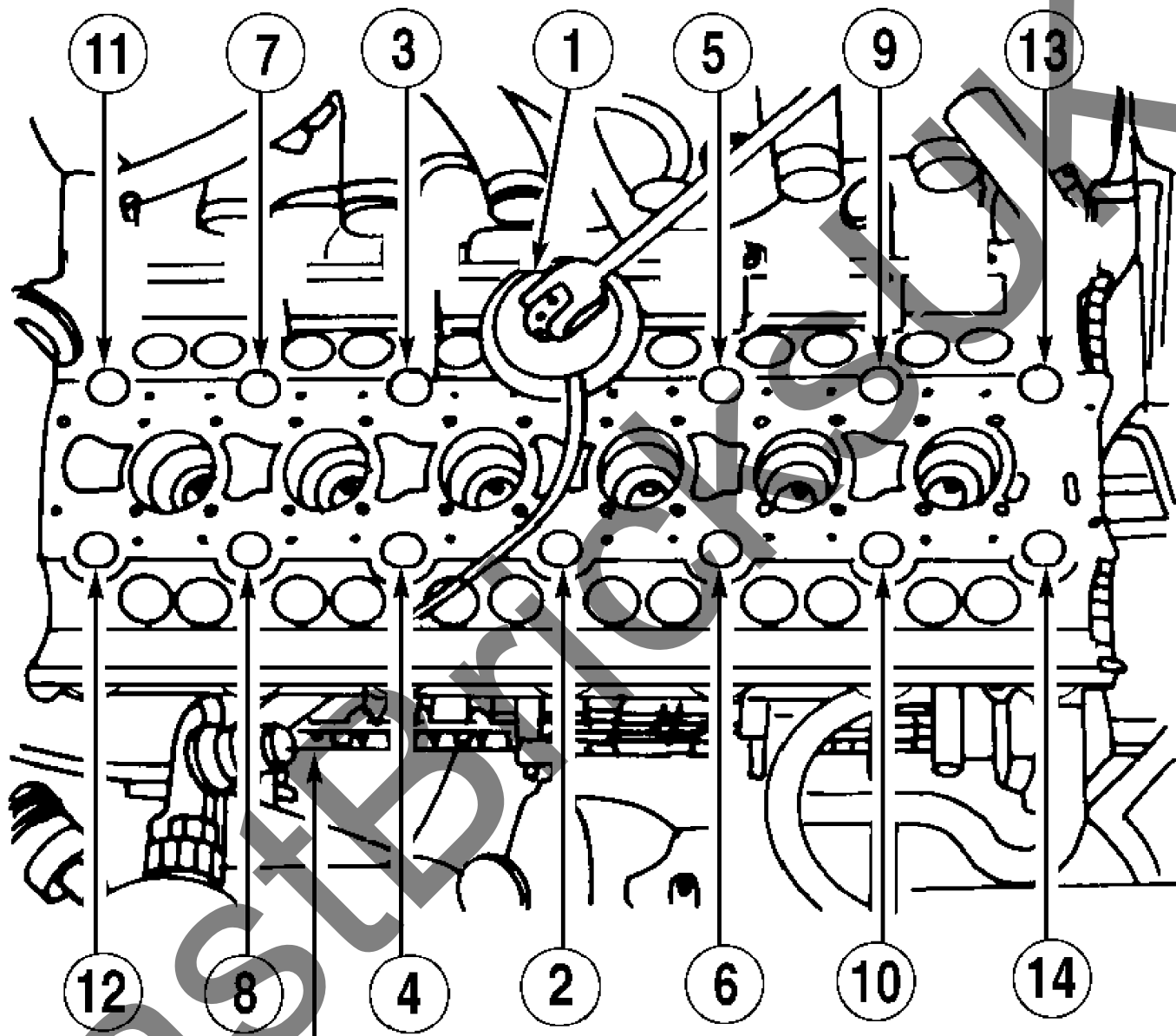

Fig. 3: Attaching Crankshaft Locking Tool (5451)
Courtesy of Volvo Cars of North America.



93001227

Bottom Half Of Cylinder Head

Fig. 4: Cylinder Head Bolt Tightening Sequence (960)
 Courtesy of Volvo Cars of North America.

2) On all engines, install NEW cylinder head gasket and "O" rings in spark plug wells. Oil the lower camshaft bearing seats. Using a roller, apply Sealing Compound (1 161 059-9) to upper section of cylinder head. Ensure sealer does not penetrate oil passages. Oil upper camshaft bearing seats. Install camshafts in upper cylinder head section, using Holder (5453) at front and Locking Tool (5452) at rear to secure camshafts. See Fig. 5.

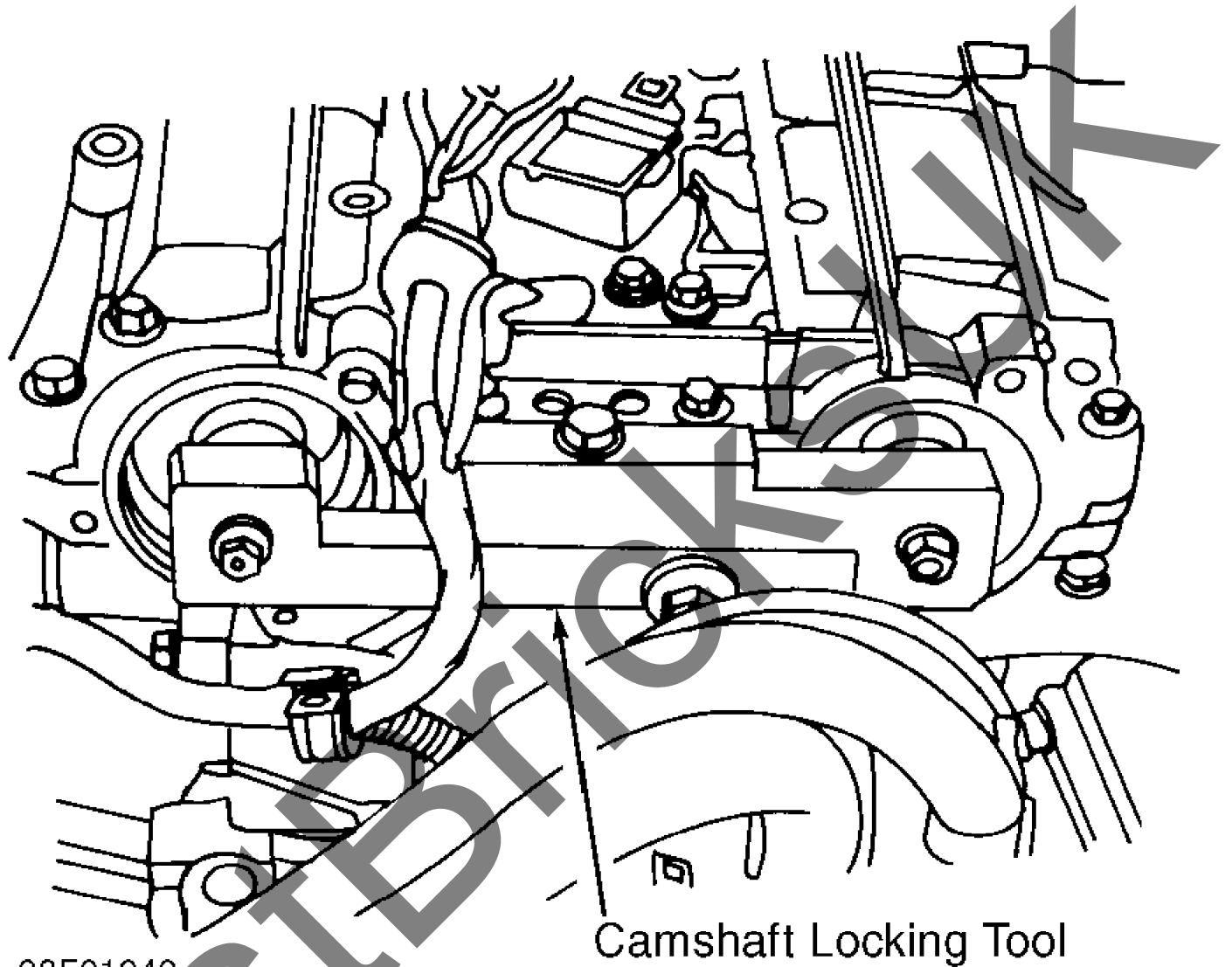

93F01243

Fig. 5: Using Locking Tool (5452) To Secure Camshafts
Courtesy of Volvo Cars of North America.

3) Install upper cylinder head. Tighten against lower section using 2 Press Tools (5454). Tighten retaining bolts to 13 ft. lbs. (17 N.m), starting from inside and working outward. Remove 2 press tools.

4) Using Drift (5449), install camshaft front seals. On 960, place upper transmission cover in position. On both engines, install camshaft pulleys and align timing marks. See Fig. 6. Tighten each pulley with 2 bolts, just until bolts are in contact with pulleys. On 960, remove upper transmission cover. Insert transmission mounting plate bolt.

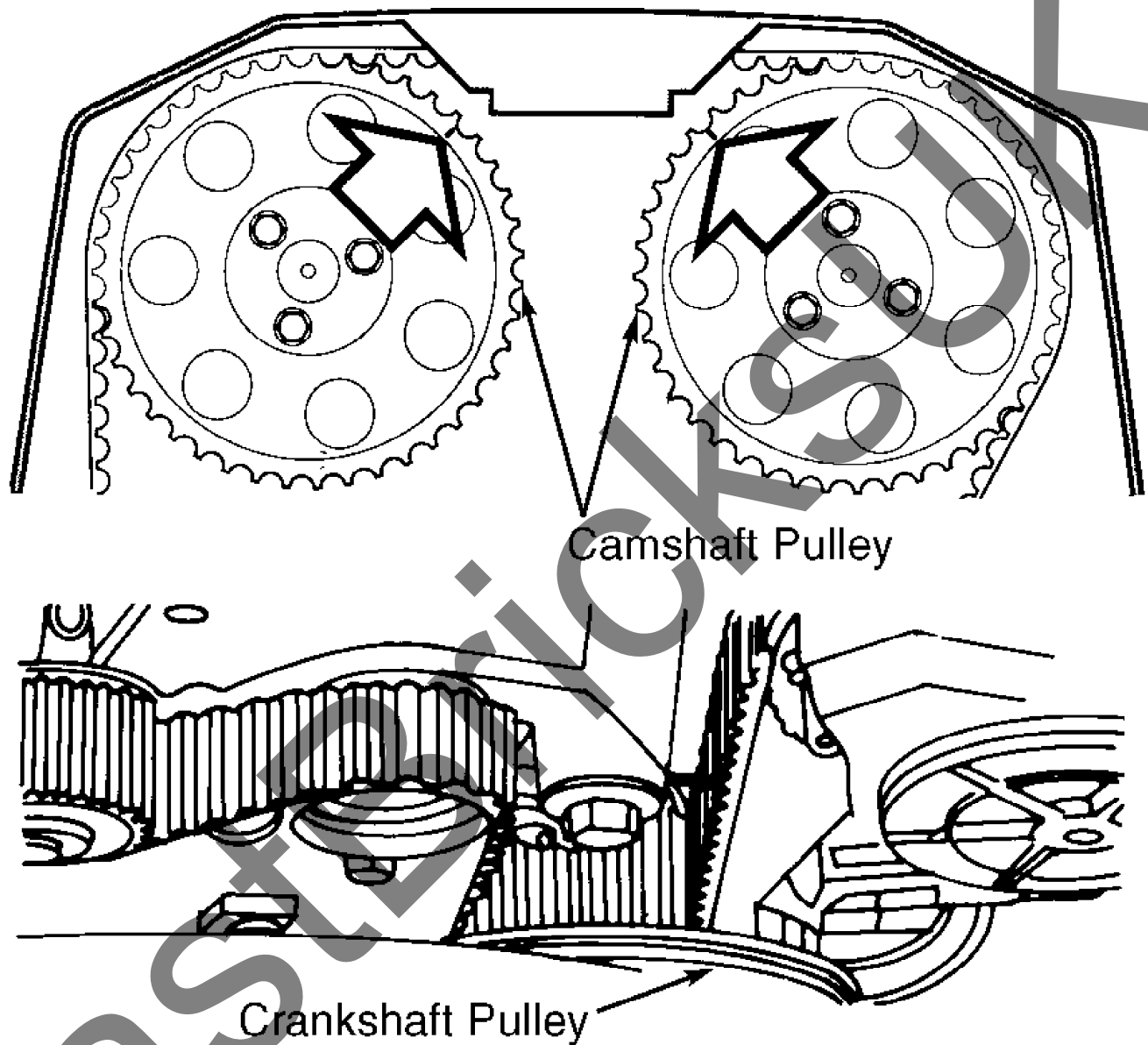

93E01228

Fig. 6: Aligning Camshaft & Crankshaft Timing Marks
 Courtesy of Volvo Cars of North America.

5) Place timing belt around crankshaft and right idler. Place belt over camshaft pulleys, around coolant pump and press over tensioner pulley. Install belt tensioner and tighten bolts to 18 ft. lbs. (25 N.m). On both engines, loosen camshaft pulley bolts and remove tensioner locking pin.

6) Install third camshaft pulley bolt. Hold camshaft pulleys still and tighten bolts alternately to 15 ft. lbs. (20 N.m). Remove crankshaft locking tool and install protective plug. Install starter. Remove camshaft locking tool. Install upper transmission cover.

7) Turn crankshaft through 2 revolutions. Ensure timing marks on crankshaft and camshaft pulleys are correctly aligned. See Fig. 6. Use Drift (5450), and install right rear camshaft seal. See Fig. 7.

8) In left rear camshaft area, reconnect temperature sensor connector, ground terminals No. 1 and 2, cover, switch mounting

bracket, shutter (noting position), camshaft position sensor and coolant hoses. Install ignition coils, spark plug cover, front transmission cover, accessory drive belt, vibration damper guard and splash guard under engine.

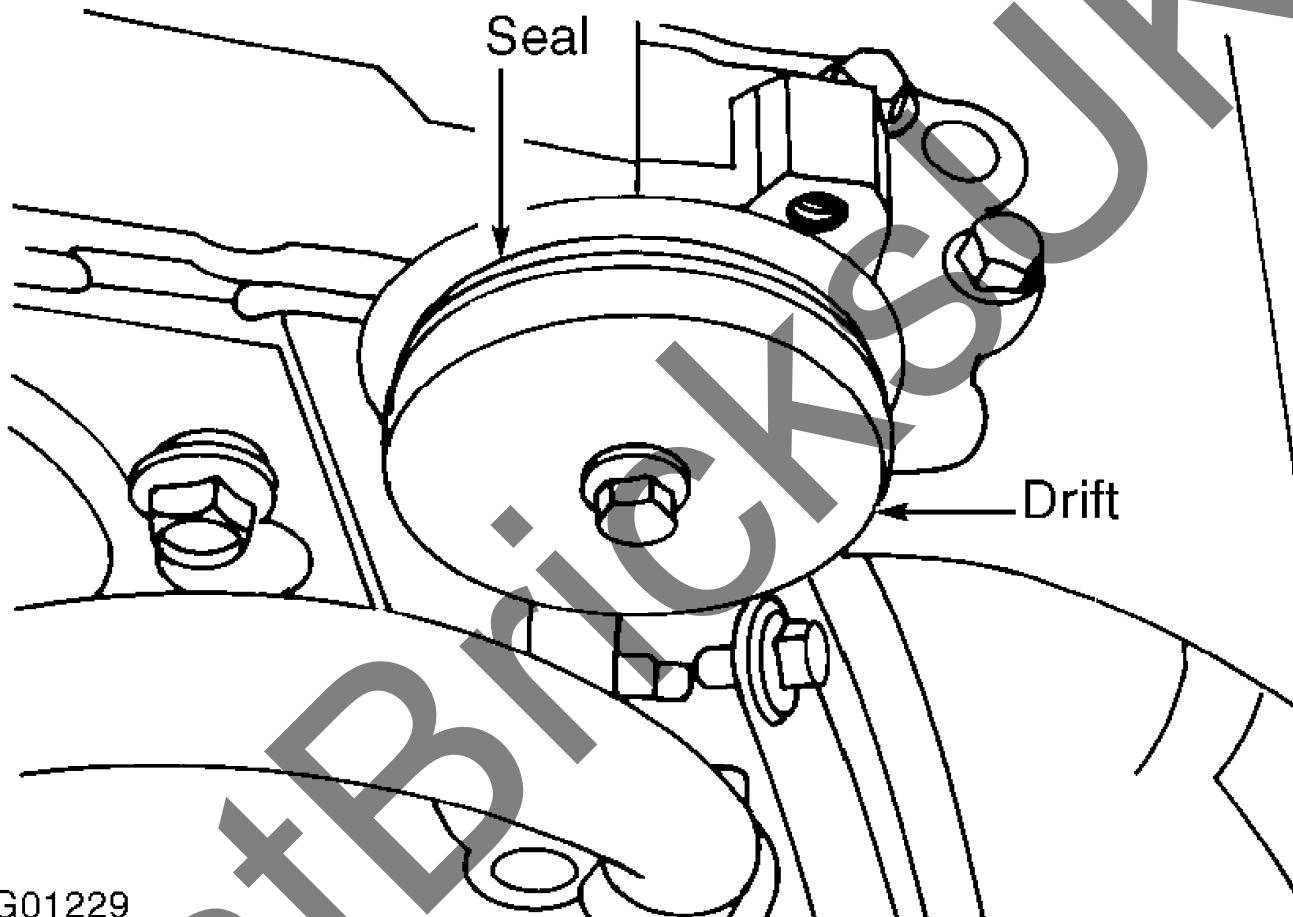

93G01229

Fig. 7: Installing Seal Using Drift (5450)
Courtesy of Volvo Cars of North America.

9) Pass wiring between second and third branches of intake manifold. See Fig. 8. Place manifold in position against lower mounting. Place 2 crankcase ventilation hoses in position. Insert manifold branches in rubber sleeves and secure with NEW clamps. Reconnect vacuum hoses and brake servo hose. Tighten lower manifold mounting. Reconnect power stage connectors and air preheater hose.

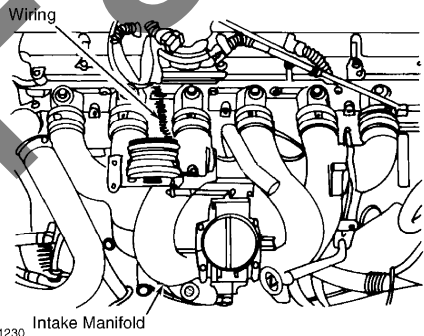

93101230
Fig. 8: Second & Third Branches Of Intake Manifold Wiring (960)
Courtesy of Volvo Cars of North America.

10) Using water-free petroleum jelly, install injector "O" rings. Reconnect fuel pressure regulator vacuum hose. Press fuel distribution manifold into position and tighten manifold. Reconnect injector connectors and ECC vacuum hoses. Reinstall injector cover.

11) Reconnect crankcase ventilation hoses. Reconnect idling valve lead and air hose. Reconnect air mass meter and throttle housing connector. Install cable bracket at throttle pulley. Install coolant hose to thermostat housing. Reconnect coolant temperature sensor.

12) On right side of cylinder head install coolant pipe and gasket, exhaust manifold and gasket, heat shield, and front exhaust pipe. To prevent stress on exhaust system, loosen bolted joint after catalytic converter and retighten to 18 ft. lbs. (25 N.m). Reconnect battery. Fill engine with oil and coolant. Start and run engine until it reaches normal operating temperature. Check for leaks.

CRANKSHAFT FRONT SEAL

Removal (960)

1) Remove auxiliary drive belt, front transmission cover, cooling fan and splash guard under engine. Drain coolant and remove radiator. Turn crankshaft clockwise until timing marks on camshaft pulleys/transmission mounting plate and crankshaft pulley/oil pump housing are aligned. See Fig. 6. Remove upper transmission cover.

2) Attach Counterhold (5433) to damper to prevent it from turning. Remove 4 vibration damper mounting bolts. Remove center nut and counterhold. Remove vibration damper. Remove timing belt. See TIMING BELT. Use puller to remove crankshaft pulley. Remove oil seal with a screwdriver.

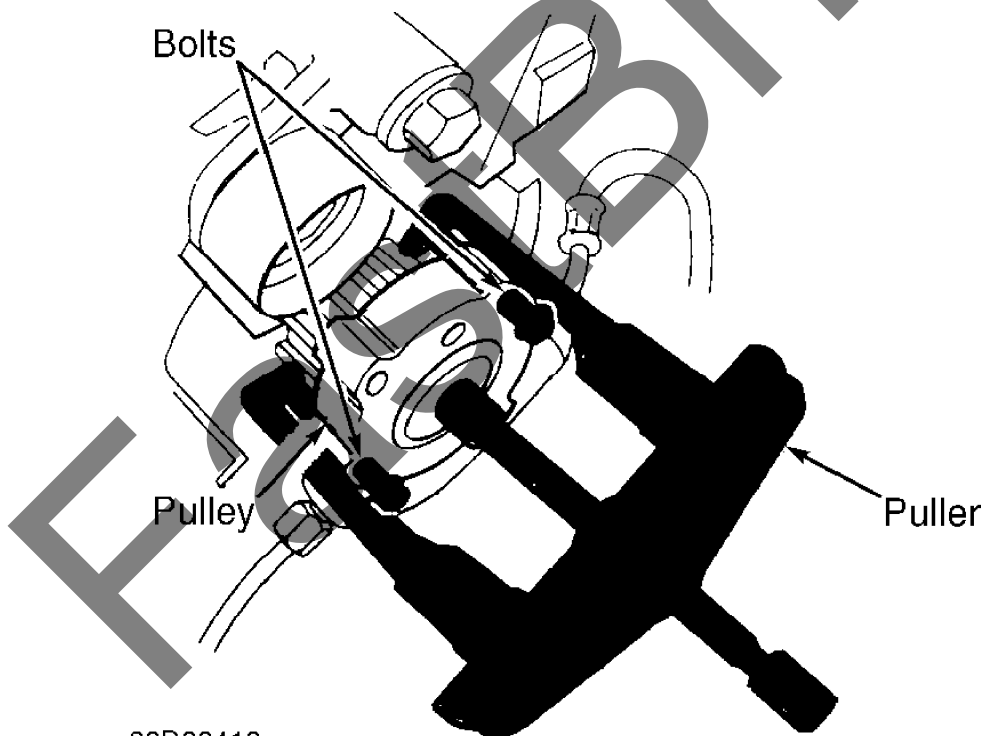

93D83413

Fig. 9: Removing Crankshaft Belt Pulley
Courtesy of Volvo Cars of North America.

Installation

1) Clean seat and install new greased seal. Press in seal

using crankshaft center nut. Install timing belt. See TIMING BELT.

2) Install vibration damper and tighten center nut to 221 ft. lbs. (300 N.m). Using Counterhold (5433) to hold crankshaft still, tighten 4 damper bolts to 26 ft. lbs. (35 N.m), then an additional 60 degrees.

3) Install upper transmission cover. Turn crankshaft through 2 revolutions and ensure timing marks on crankshaft and camshaft pulleys are aligned. See Fig. 6. Install ignition coil cover.

4) Install radiator, front transmission cover, drive belt, splash guard under engine and cooling fan. Fill cooling system with coolant. Check oil level. Start engine and check for leaks.

TIMING BELT

Removal

1) Remove auxiliary drive belt, front transmission cover, splash guard under engine, vibration damper guard and ignition coil cover. Turn crankshaft clockwise until timing marks on camshaft pulleys/transmission plate and crankshaft pulley/oil pump housing are aligned. See Fig. 6. Remove upper transmission cover.

4) On both engines, remove tensioner upper mounting bolt and loosen lower mounting bolt. Twist tensioner to free plunger/pulley. Remove lower bolt, tensioner and belt.

CAUTION: DO NOT turn crankshaft or camshafts while belt is removed.

Inspection

1) Spin tensioner and idler pulleys and listen for bearing noise. See Fig. 10.

2) Ensure pulley surfaces in contact with belt are clean and smooth. Check tensioner pulley arm and idler pulley mountings, and tighten bolts as necessary. See TORQUE SPECIFICATIONS. Check tensioner for signs of leakage, no resistance when depressed, or a plunger that cannot be depressed.

Tensioner & Idler Pulleys

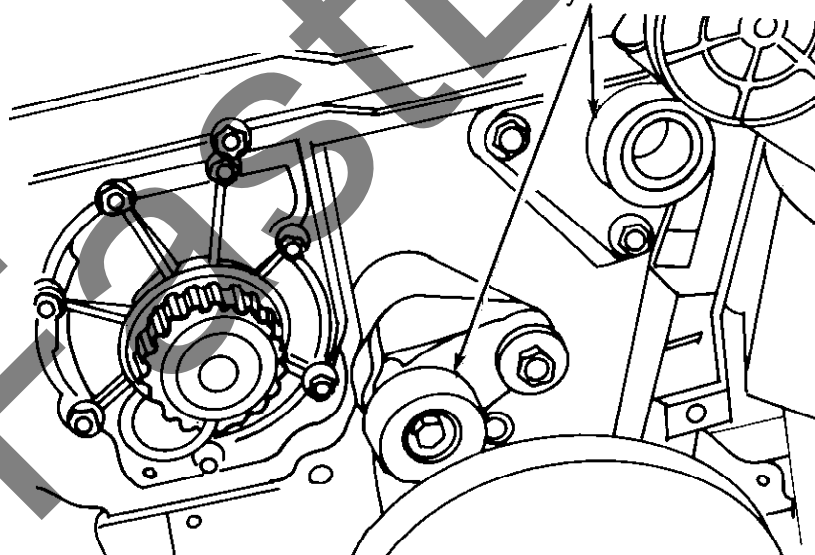

93H01244

Fig. 10: Checking Tensioner & Idler Pulleys
Courtesy of Volvo Cars of North America.

Installation

1) Compress tensioner and tighten center nut. Wait until

compression has taken place and insert a 2 mm locking pin in plunger. Install tensioner and tighten mounting bolts to 18 ft. lbs. (25 N.m). Place timing belt around crankshaft pulley and right idler. Place belt over camshaft pulleys. Position belt around water pump and press over tensioner pulley.

2) Remove tensioner locking pin. To complete installation, reverse removal procedure. Turn crankshaft 2 revolutions to ensure timing marks on 5crankshaft and camshaft pulleys are aligned. See Fig. 6.

CAMSHAFTS

Removal

For camshaft removal and installation, see CYLINDER HEAD under REMOVAL & INSTALLATION.

FRONT & REAR CAMSHAFT OIL SEALS

Removal (Front)

1) Disconnect negative battery cable.
2) Remove timing belt. See TIMING BELT. Use Counterhold (5199) to hold camshaft stationary. See Fig. 11. Remove camshaft pulleys. Using a screwdriver, carefully pry out front seals. Clean seats and check shafts for wear.

Installation

Using Drift (5449), install new front seal.

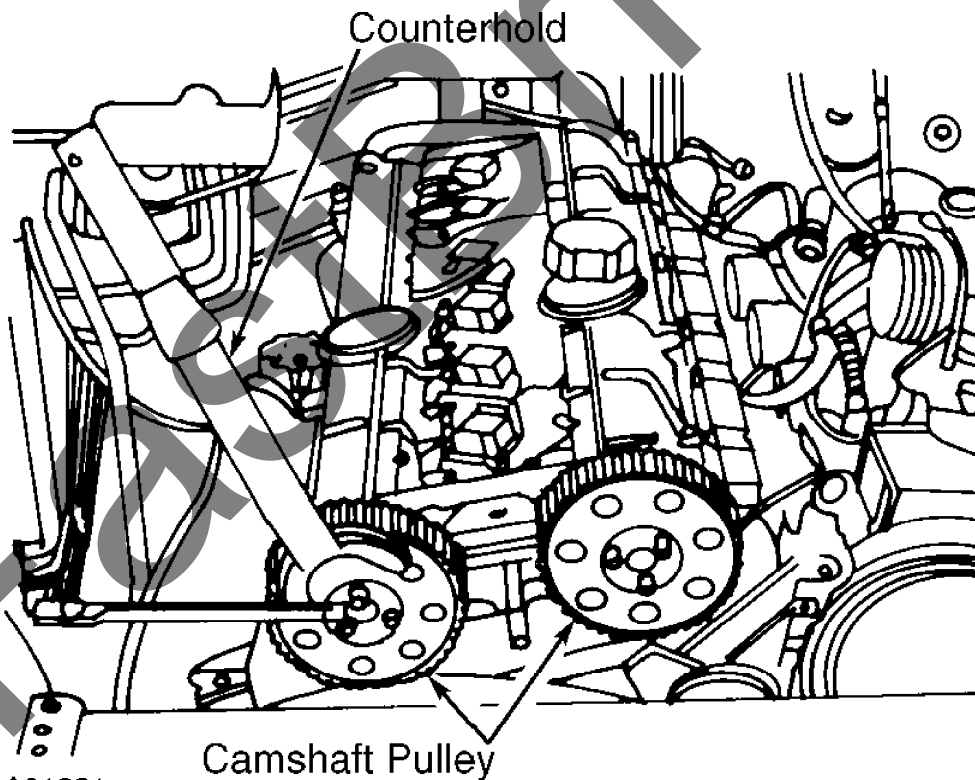

Fig. 11: Using Counterhold (5199) To Hold Camshaft Stationary
Courtesy of Volvo Cars of North America.

Removal (Rear)

On left camshaft, remove camshaft position sensor and

shutter. On right camshaft, remove camshaft seal cover. On both engines, carefully pry out seal with screwdriver. Clean seal seat and check shaft end for signs of wear.

Installation

Using Drift (5450), install a new greased rear camshaft oil seal. See Fig. 7. Seal is located on same plane as edge of inside shoulder. To complete installation, reverse removal procedure.

REAR CRANKSHAFT OIL SEAL

Removal

1) Support rear of engine. Move gear selector lever to Neutral. Disconnect negative battery cable. Using Support Rails (5033), Lifting Beam (5006), Lifting Hook (5115), Lifting Lug (5429) and Lifting Yoke (5186), support engine. Remove air preheater pipe under engine.

2) Remove nuts and disconnect front section of exhaust pipe. Disconnect transmission fluid cooling lines and plug openings. Disconnect 3 transmission electrical connectors. Disconnect oxygen sensor lead from transmission unit and support member.

3) Mark propeller shaft for reassembly reference and separate front coupling halves. Disconnect gear selector lever. Remove transmission support member. Using Lifting Beam (5006), lower engine and transmission, ensuring hoses and wiring do not catch on components.

4) Remove 6 bolts securing torque converter to flywheel. Position Fixture (5972) under transmission. Remove transmission housing bolts. Tilt transmission slightly backwards while lowering to prevent torque converter from sliding off shaft. Working through inspection hole, carefully pry torque converter loose from flywheel. Remove flywheel.

5) Using a screwdriver, carefully pry out crankshaft seal. Clean seat and inspect shaft for signs of wear.

Installation

1) Oil mating surfaces between seal and seat. Place seal on Seal Installer (5430). Tap in seal until drift bottoms against crankshaft. Install flywheel using NEW bolts and Loctite. Tighten bolts to 33 ft. lbs. (45 N.m). Tighten bolts an additional 50 degrees.

2) Using Fixture (5972), install transmission. Align transmission with flywheel and tighten transmission in position. Finger tighten torque converter-to-flywheel bolts, then alternately tighten bolts to 22 ft. lbs. (30 N.m).

3) Lift transmission and install support member. Tighten bolts to 37 ft. lbs. (50 N.m). Tighten nut securing bump stop to support member to 37 ft. lbs. (50 N.m).

4) Install gear select lever. Reconnect oil cooling lines and connectors. Reconnect transmission connectors and oxygen sensor lead. Reinstall propeller shaft. Lubricate "O" ring with petroleum jelly and install preheater pipe. Install front section of exhaust pipe. Remove all lifting tools. Reconnect negative battery cable. Check transmission fluid level. Check transmission operation.

WATER PUMP

Removal

Remove expansion tank cap and drain coolant. Remove timing belt. See TIMING BELT. Remove bolts holding water pump to engine block. See Fig. 12. Remove water pump.

Installation

Remove old gasket from cylinder block. Install water pump.

Tighten mounting bolts alternately to 15 ft. lbs. (20 N.m). Install timing belt. See TIMING BELT. Fill engine with coolant. Start engine and check for leaks.

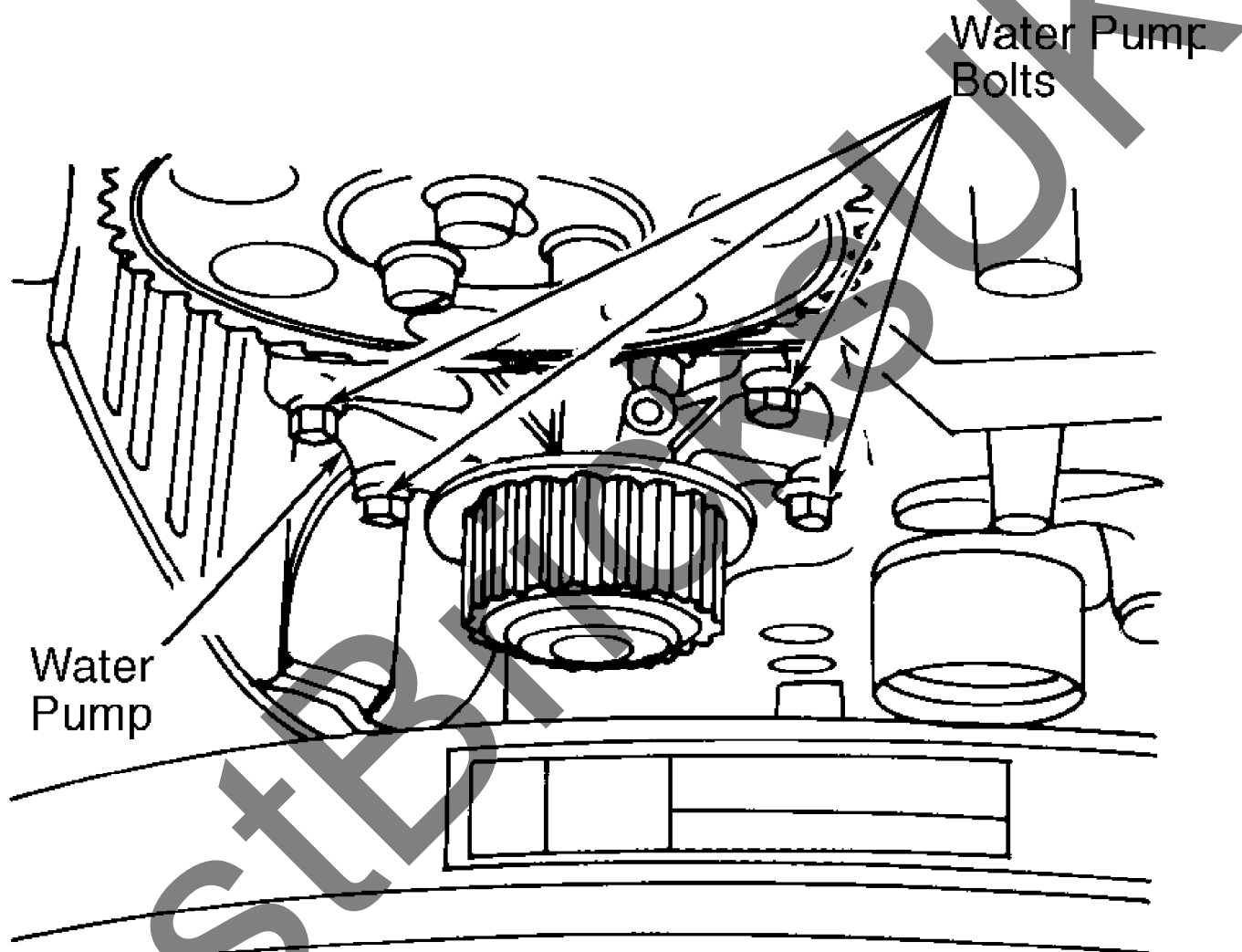

93C01232

Fig. 12: Removing Water Pump
Courtesy of Volvo Cars of North America.

NOTE: For cooling system servicing procedures not covered in this article, see the GENERAL COOLING SYSTEM SERVICING article in GENERAL INFORMATION. Also, see ENGINE COOLING FAN article for electric cooling fan tests, COOLING SYSTEM SPECIFICATIONS for capacities, or DRIVE BELT ROUTING for drive belt routing views in the ENGINE COOLING section.

OIL PUMP

Removal (960)

1) Remove auxiliary drive belt, front transmission cover, cooling fan and splash guard under engine. Drain coolant and remove radiator.

2) Turn crankshaft clockwise until timing marks on camshaft pulleys/transmission mounting plate and crankshaft pulley/oil pump

housing are aligned. Remove upper transmission cover.

3) Remove 4 mounting bolts from vibration damper. Attach Counterhold (5433) to keep damper from turning. Remove center nut from damper. Remove counterhold and vibration damper. Remove tensioner upper mounting bolt. Loosen lower mounting bolt. Twist tensioner until plunger is released. Remove lower mounting bolt. Remove timing belt.

4) Using puller, remove crankshaft pulley. Remove oil pump retaining bolts. See Fig. 13. Clean joint faces and mating surfaces.

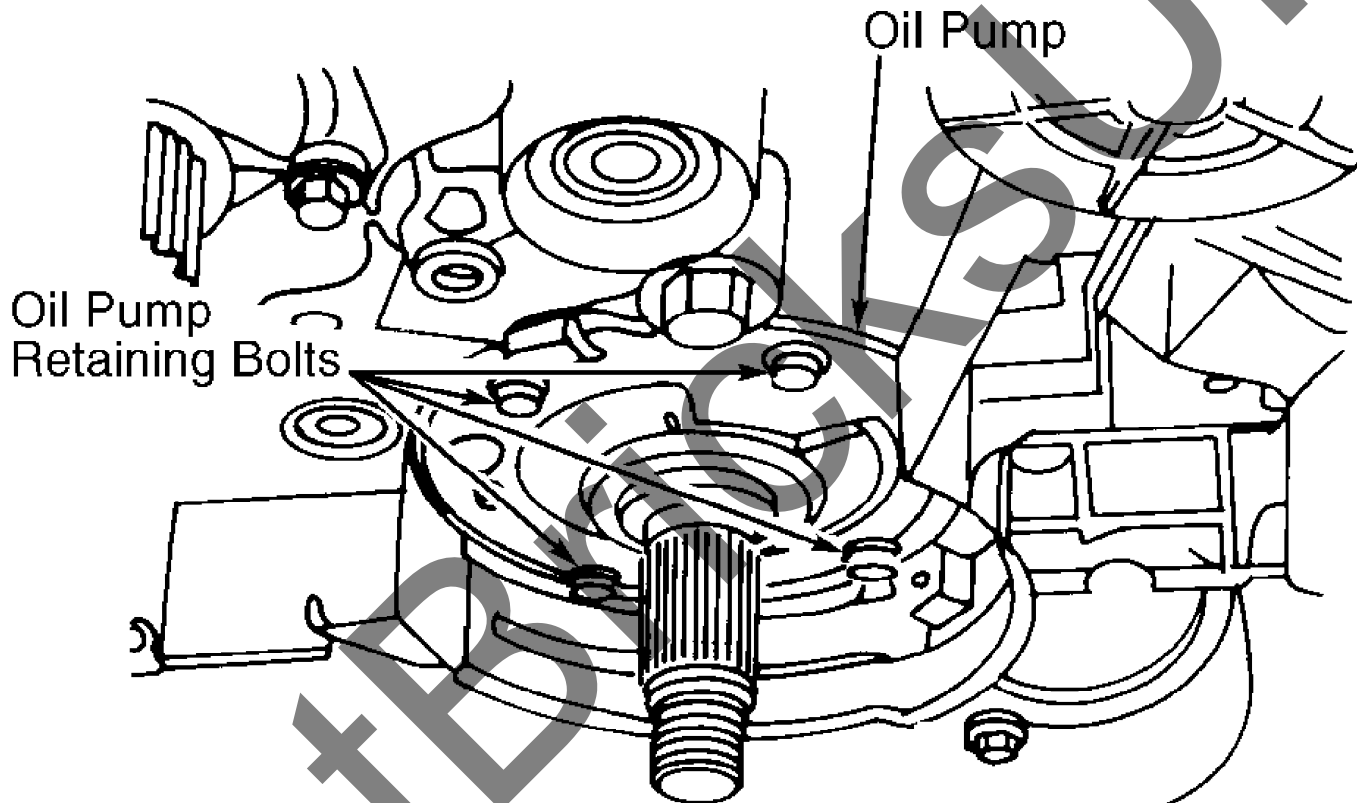

93E01233

Fig. 13: Removing Oil Pump Retaining Bolts
Courtesy of Volvo Cars of North America.

Inspection

Check all oil pump components for damage and wear. Closely inspect crescent between suction and delivery sides. If any defective components are found, replace entire pump assembly.

Installation

1) Using Drift (5455), install oil pump. Use bolts as guides. Pull in pump using crankshaft center nut. Apply Loctite and tighten bolts alternately to 84 INCH lbs. (10 N.m). Install crankshaft pulley using center bolt and spacer.

2) Place timing belt around crankshaft pulley and right idler. Place belt over camshaft pulleys. Position belt around water pump and press over tensioner pulley. Install tensioner and tighten bolts to 18 ft. lbs. (25 N.m). Remove locking pin.

3) Install Counterhold (5433) to prevent crankshaft from turning. Install vibration damper and tighten center nut to 221 ft. lbs. (300 N.m). Tighten 4 retaining bolts to 26 ft. lbs. (35 N.m), plus an additional 60 degrees.

4) Install upper transmission cover. Turn crankshaft 2 revolutions and ensure timing marks on crankshaft and camshaft pulleys

are aligned. Install ignition coil cover. See Fig. 6.

5) Install radiator, front transmission cover, auxiliary drive belt, splash guard under engine and cooling fan. Fill cooling system. Check oil level and test run engine.

OVERHAUL

CYLINDER HEAD

Cylinder Head

Ensure all mating surfaces are clean. Measure cylinder head warpage. If longitudinal warpage is less than .020" (.50 mm), or lateral warpage is less than .008" (.20 mm), resurfacing is not required. If warpage is greater than specifications, resurface cylinder head. Maximum resurface limit is .011" (.30 mm).

Valve Springs

Measure valve spring free length. Replace any spring shorter than minimum free length specification. See VALVE SPRING FREE LENGTH in VALVES & VALVE SPRINGS table under ENGINE SPECIFICATIONS.

Valve Stem Oil Seals

Place new seal on valve stem. Remove protective sleeve. Using Drift (5379), push seal onto stem by hand only as far as possible. DO NOT use a hammer to install valve stem seals.

Valve Guides

Three replacement valve guides are available. Standard valve guide has no grooves at top and is .472" (12 mm) in diameter. First oversize valve guide has one groove at top and is .476" (12.1 mm) in diameter. Second oversize valve guide has 2 grooves at top and is .480" (12.2 mm) in diameter.

Valve Seat

Replacement procedure is not available from manufacturer.

Valves

Check valve for wear or burning. Measure valve dimensions after refacing. Replace any valve that does not meet specification. See VALVES & VALVE SPRINGS table under ENGINE SPECIFICATIONS. Measure valve stem installed height after refinishing valve or seat. See CYLINDER HEAD table under ENGINE SPECIFICATIONS.

Valve Seat Correction Angles

Ensure valve seat angles are within specification. For face angle, see VALVES & VALVE SPRING table under ENGINE SPECIFICATIONS. Upper relief angle is 15 degrees. Lower relief angle is 70 degrees.

CYLINDER BLOCK ASSEMBLY

Piston & Rod Assembly

1) Carefully press out pistons and connecting rods by hand. Mark pistons and connecting rods for reassembly reference. Carefully pry out piston pin locking circlip with a screwdriver. Clean and inspect all components for damage. Check connecting rod cap bolt length. Maximum length is 2.16" (55 mm).

2) Check piston pin fit in connecting rod. No play should be present as pin should slide through hole with gentle thumb pressure. Replace piston as necessary. Check piston pin fit in connecting rod in same manner. If pin fails to slide through hole without play when pressed with thumb, install NEW connecting rod bushing. Ensure numerical designation on connecting rod faces toward starter motor

side of block.

Fitting Pistons

Install pistons using Piston Ring Compressor (115 8281). Ensure arrow on top of piston faces toward timing belt end of engine.

Piston Rings

1) Using Piston Ring Pliers (998 5424), remove piston rings. Remove carbon deposits. Scrape ring grooves clean. Check pistons for damage and repair as necessary. Check piston ring side play and piston diameter. See PISTONS, PINS & RINGS under ENGINE SPECIFICATIONS.

2) Using Piston Ring Pliers (998 5424), install piston rings so gaps are 120 degrees apart. Install upper compression and oil scraper rings with text facing upward. Install lower compression ring with groove facing downward.

Crankshaft & Main Bearings

1) Remove engine from vehicle. See ENGINE under REMOVAL & INSTALLATION. Remove cylinder head. See CYLINDER HEAD under REMOVAL & INSTALLATION. Place engine upside down. Remove oil filter. Disconnect flame trap return line. Remove oil pan. Remove all oil passage "O" rings. Remove oil pump suction pipe and "O" ring.

2) Rotate crankshaft so all piston connecting rod bolts are accessible for removal without rotating crankshaft again. Starting at sides and working toward center, remove intermediate section bolts. Loosen intermediate section by carefully tapping with a plastic mallet. Remove crankshaft rear seal.

CAUTION: DO NOT allow crankshaft to rotate.

3) Check identification markings on connecting rods and connecting rod caps. Mark components for reassembly reference as necessary. Remove connecting rod caps. Lift crankshaft out of block and support on "V" blocks on 2 outermost main journals. Remove main bearings from block. Mark position of thrust bearing for reassembly reference.

4) Use micrometer and measure crankshaft out-of-round and taper. Ensure to measure at several points around circumference and along length. Use Dial Gauge (9684) and Magnetic Stand (9696) to check straightness of crankshaft. See ENGINE SPECIFICATIONS.

5) Check classification markings on cylinder block and crankshaft before installing crankshaft main bearings. Main bearings are color-coded Yellow, Blue and Red. Torque intermediate section bolts in 5 stages. Each stage should be completely torqued before beginning another stage. See Fig. 14. See TORQUE SPECIFICATIONS. After main bearings are installed and intermediate section is tightened, check crankshaft end play.

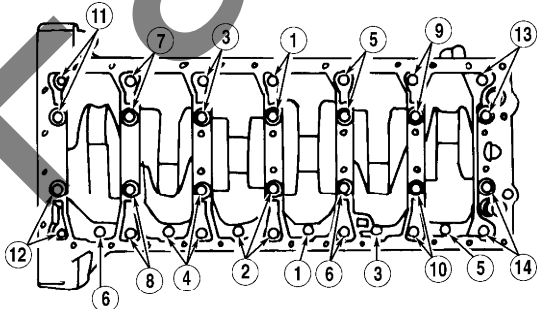

93E83414

Fig. 14: Tightening Sequence
Courtesy of Volvo Cars of North America.

Thrust Bearing

Ensure thrust bearing is marked for reassembly reference.

Cylinder Block

1) Wipe bores clean and visually check. Measure bores using Dial Gauge (9639), Micrometer (9704), and micrometer stand. Use dial gauge and check for maximum wear at right angles to center line of engine immediately below top dead center. Check for minimum wear in direction of center line at bottom dead center.

2) Each cylinder is identified by a classification mark (C, D, E, or G) punched in rear of block. Oversize bores can be indicated by OS1 or OS2. See CYLINDER BLOCK under ENGINE SPECIFICATIONS.

ENGINE OILING

ENGINE LUBRICATION SYSTEM

Crankcase Capacity

Oil capacity is 5.9 qts. (5.7L) with filter. See Fig. 15.

Oil Pressure

Oil pressure is 14 psi (.10 bar) at idle and 43 psi (.30 bar) at 3000 RPM. See Fig. 15.

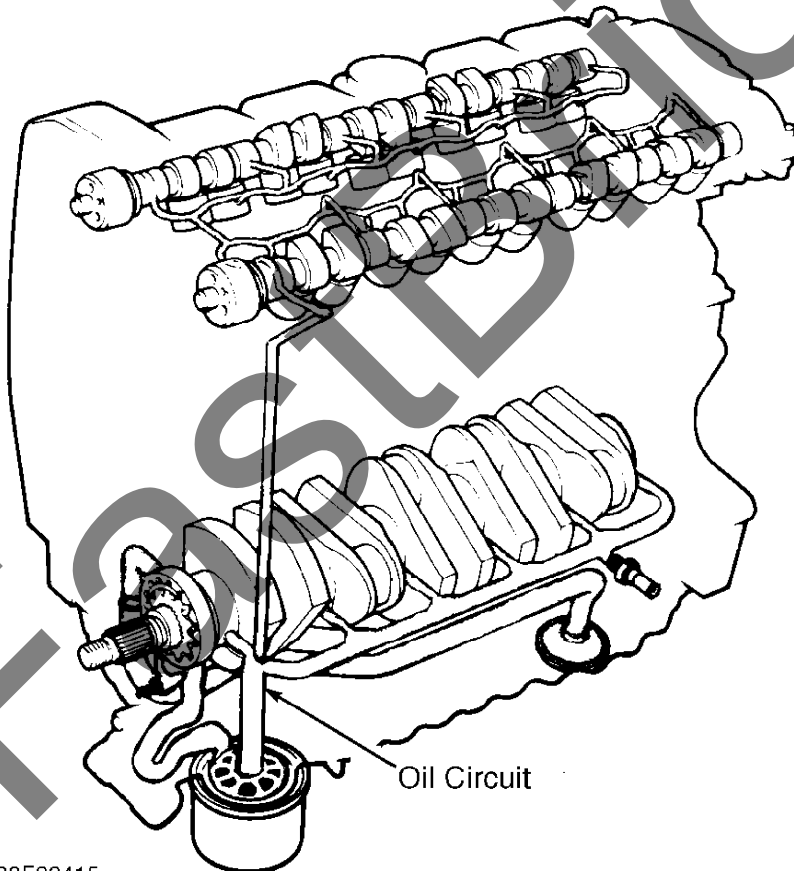

93F83415

Fig. 15: Oil Schematic ((5-Cylinder Shown; 6-Cylinder Similar)
Courtesy of Volvo Cars of North America.

TORQUE SPECIFICATIONS

TORQUE SPECIFICATIONS

Application	Ft. Lbs. (N.m)
Bump Stop-To-Support Member Bolt	37 (50)
Camshaft Cover Bolt	13 (17)
Camshaft Pulley Bolt	15 (20)
Connecting Rod Bearing Cap Bolt	(1) 15 (20)
Cylinder Block (Intermediate Section)	
Stage No. 1 (M10 Bolt)	15 (20)
Stage No. 2 (M10 Bolt)	33 (45)
Stage No. 3 (M8 Bolt)	18 (25)
Stage No. 4 (M7 Bolt)	13 (17)
Stage No. 5 (M10 Bolt)	(1)
Cylinder Head Bolt	
Stage No. 1	15 (20)
Stage No. 2	44 (60)
Stage No. 3	(2)
Engine Mount Top Nut	37 (50)
Exhaust Manifold-To-Cylinder Head Nut	18 (25)
Exhaust System Bolt Behind	
Catalytic Converter	18 (25)
Flywheel-To-Crankshaft Bolt	(3) 33 (45)
Gearbox-To-Engine Bolt	37 (50)
Heat Shield Bolt	11 (15)
Intake Manifold Bolt	15 (20)
Knock Sensor Bolt	15 (20)
Spark Plug	18 (25)
Timing Belt Pulley Bolt	30 (40)
Timing Belt Tensioner Bolt	18 (25)
Torque Converter-To-Flywheel Bolt	22 (30)
Transmission Bump Stop Nut	37 (50)
Transmission Oil Cooler Fittings	22 (30)
Transmission Support Member Bolt	37 (50)
Upper Cylinder Head Retaining Bolt	13 (17)
Vibration Damper Bolt	(4) 26 (35)
Vibration Damper Center Nut	221 (300)
Water Pump Bolt	15 (20)

INCH Lbs. (N.m)

Oil Pump Bolt	84 (10)
---------------	---------

- (1) - Tighten an additional 90 degrees.
- (2) - Tighten an additional 130 degrees.
- (3) - Tighten an additional 50 degrees.
- (4) - Tighten an additional 60 degrees.

ENGINE SPECIFICATIONS

GENERAL ENGINE SPECIFICATIONS

GENERAL ENGINE SPECIFICATIONS

Application	Specification
Displacement	2.9L
Bore	3.26" (83 mm)
Stroke	3.54" (90 mm)
Compression Ratio	10.7:1
Fuel System	MFI

Horsepower @ RPM 204 @ 6000
 Torque Ft. Lbs. @ RPM 197 @ 4300

CRANKSHAFT, MAIN & CONNECTING ROD BEARINGS

CRANKSHAFT, MAIN & CONNECTING ROD BEARINGS

Application	In. (mm)
Crankshaft	
End Play003-.007 (.08-.19)
Runout0013 (.032)
Main Bearings	
Journal Diameter	2.5 (65)
Journal Out-Of-Round0002 (.004)
Journal Taper0002 (.004)
Oil Clearance001-.002 (.02-.04)
Connecting Rod Bearings	
Journal Diameter	1.96 (50)
Journal Out-Of-Round0002 (.004)
Journal Taper0002 (.004)

CONNECTING RODS

CONNECTING RODS

Application	In. (mm)
Crankpin Bore Diameter	2.08 (53)
Out-Of-Round Maximum0002 (.004)
Side Play006-.018 (.15-.45)

PISTONS, PINS & RINGS

PISTONS, PINS & RINGS

Application	In. (mm)
Pistons	
Clearance0003-.0011 (.010-.030)
Diameter	
Size C	3.2669-3.2673 (82.980-82.990)
Size D	3.2673-3.2677 (82.990-83.000)
Size E	3.2677-3.2681 (83.000-83.010)
Size G	3.2683-3.2689 (83.017-83.032)
Oversize 1	3.2746-3.2752 (83.177-83.192)
Oversize 2	3.2825-3.2831 (83.377-83.392)
Pins	
Diameter9 (23)
Rings	
No. 1	
End Gap008-.016 (.20-.40)
Side Clearance0019-.0030 (.050-.085)
No. 2	
End Gap008-.016 (.20-.40)
Side Clearance0012-.0026 (.030-.065)

No. 3 (Oil)	
End Gap009-.020 (.25-.50)
Side Clearance0008-.0022 (.020-.055)

CYLINDER BLOCK

CYLINDER BLOCK

Application	In. (mm)
Cylinder Bore	
Size C	3.2677-3.2681 (83.000-83.010)
Size D	3.2681-3.2685 (83.010-83.020)
Size E	3.2645-3.2688 (83.020-83.030)
Size G	3.2692-3.2696 (83.040-83.050)
Oversize 1	3.2755-3.2759 (83.200-83.210)
Oversize 2	3.2834-3.2838 (83.400-83.410)
Maximum Taper004 (.10)
Maximum Out-Of-Round004 (.10)
Deck Height	5.20 (132.1)
Maximum Machining012 (.30)
Maximum Deck Warpage	
Length020 (.50)
Width008 (.20)

VALVES & VALVE SPRINGS

VALVES & VALVE SPRINGS

Application	Specification
Intake Valves	
Face Angle	44.5°
Head Diameter	1.568-1.580" (39.85-40.15 mm)
Minimum Margin047" (1.2 mm)
Length	3.85-3.87" (97.8-98.4 mm)
Stem Diameter273-.274" (6.95-6.97 mm)
Valve Tip Maximum Refinish015" (.40 mm)
Exhaust Valves	
Face Angle	44.5°
Head Diameter	1.568-1.580" (39.85-40.15 mm)
Minimum Margin047" (1.2 mm)
Length	3.811-3.834" (96.8-97.4 mm)
Stem Diameter274-.275" (6.97-6.99 mm)
Valve Tip Maximum Refinish015" (.40 mm)
Valve Springs	
Free Length	1.70" (43.2 mm)
	Lbs. @ In. (N @ mm)
Pressure	
Valve Closed	61 @ 1.3 (270 @ 34)
Valve Open	151 @ .9 (670 @ 24.5)

CYLINDER HEAD

CYLINDER HEAD

Application	Specification
-------------	---------------

Cylinder Head Height 5.076-5.080" (128.95-129.05 mm)

Maximum Warpage

Length020" (.50 mm)
Width008" (.20 mm)

Valve Seats

Intake Valve

Seat Angle 45°
Seat Width055-.070" (1.4-1.8 mm)
Maximum Seat Runout003-.004" (.07-.11mm)
Seat Bore Diameter 1.28" (32.6 mm)

Exhaust Valve

Seat Angle 45°
Seat Width070-.086" (1.8-2.2 mm)
Maximum Seat Runout003-.004" (.07-.11 mm)
Seat Bore Diameter 1.13" (28.6 mm)

Valve Guides

Valve Guide Diameter

Standard472" (12.0 mm)
Oversize 1476" (12.1 mm)
Oversize 2480" (12.2 mm)

Valve Stem-To-Guide Oil Clearance

Minimum001-.002" (.03-.06 mm)
Maximum006" (.15 mm)

CAMSHAFT

CAMSHAFT

Application In. (mm)

End Play002-.008 (.05-.20)
Lobe Lift350 (9.0)
Oil Clearance
Minimum0012 (.030)
Maximum0027 (.071)

VALVE LIFTERS

VALVE LIFTERS

Application In. (mm)

Lifter Diameter 1.375-1.378 (34.95-35.02)
