



## **PT. HYDRA ASIA ENERGY**

*Industrial Engineering Solutions*

- *Mechanical Installation*
- *PreCommissioning*
- *Pipeline Pigging & N2 Purging*
- *Nitrogen & Helium Leak Test*
- *Chemical Cleaning & Soda Boiling*
- *Aqua Milling Pipe Cleaning*
- *Hydrostatic Testing Services*
- *Flange Management*
- *Bolt Tensioning*
- *Subsea Bolt Tensioning*
- *Hydraulic Torque Wrench*
- *Hot Bolting*
- *Pipe Cold Cutting & Beveling Machine*
- *Subsea Diamond Wire Cutter*
- *Hydraulic Flange Spreader & Nut Splitter*
- *In Line Isolation and Weld Test Plug*



## ***INTRODUCTION***

We are pleased to introduce our company to your organization. We are service company specialist for on-site problems. Our quality is the provision of products and services which meet customer needs and expectations in a higher degree of confidence in the product at accost that represents value.

- ***Mechanical Installation***
- ***PreCommissioning***
- ***Pipeline Pigging & N2 Purging***
- ***Nitrogen & Helium Leak Test***
- ***Chemical Cleaning & Soda Boiling***
- ***Aqua Milling Pipe Cleaning***
- ***Hydrostatic Testing Services***
- ***Flange Management***
- ***Bolt Tensioning***
- ***Subsea Bolt Tensioning***
- ***Hydraulic Torque Wrench***
- ***Hot Bolting***
- ***Pipe Cold Cutting & Beveling Machine***
- ***Subsea Diamond Wire Cutter***
- ***Hydraulic Flange Spreader & Nut Splitter***
- ***In Line Isolation and Weld Test Plug***
- ***Isotank Rent***
- ***Evaporator Rent***
- ***N2 Pump Vaporizers / Cryogenic Pump Rent***

When your company needs the best, count on over 16 years hands-on experience solving the toughest applications. The fast, reliable, quality services of PT.Hydra Asia Energy. Prompt Services and Support Guaranteed!



## ***ON SITE SERVICE***

### ***Mechanical Installation***



Mechanical Erection is the process of preparing / making / building the place ( where the new machine or plant would be installed ) according to the product that would be mechanical Installation is setting it up in any location / side where it is to be used. Mechanical installation like a pipe rack, Piping spool, Vessel, Reactor, HE, Tank, Coloum, Tower, Mechanical joint and connection of pipe, etc.



**PT. HYDRA ASIA ENERGY**

## ***ON SITE SERVICE***

***PreCommissioning , Pipeline Pigging and Hydrostatic Testing Services  
Chemical Cleaning, Soda Boiling and Aqua Milling Pipe Cleaning***



PreCommissioning Work Including Cleaning, Gauging and Filling, Hydrotesting, Dewatering, Swabbing, Drying Purgung, Nitrogen and Helium Leak Test (Onshore & Offshore), Chemical Cleaning, Soda Boiling, and Aqua Milling Pipe Cleaning

## **ON SITE SERVICE**

### **Bolt Tensioning**

#### **Top Side Bolt Tensioning**



Hydraulic bolt tensioning is the most consistent of applying accurate pre-load to bolts. Bolt tensioning is an accurate and time saving method for tightening bolts and studs in all industries. Controlled bolt tensioning to calculated values to eliminate flange leakage. Versatile compact design ensure maximum economy over any given size range.

#### **Subsea Bolt Tensioning**

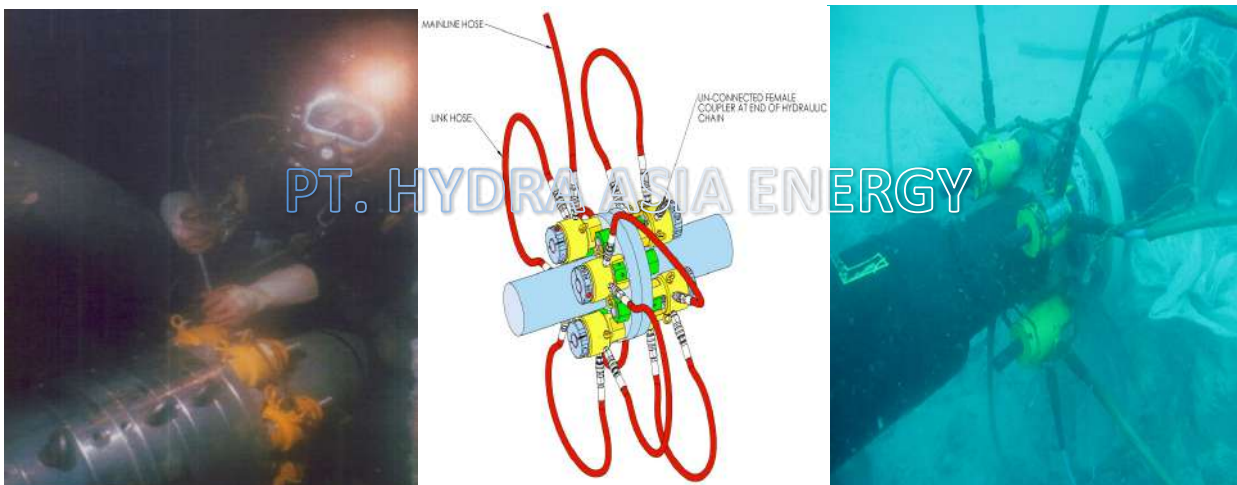

The bolt tensioners are designed for quick and accurate tensioning of pipe flanges etc. in a subsea environment. The tensioner has a minimum of parts to enable fast and simple attachment to studs where visibility is poor. Quick fastening reaction nut: allows rapid tool application and removal regardless of bolt length, corrosion or thread damage. Unique floating piston design: tilts in any direction without loss of load, eliminating piston seizure and aiding tool retraction. The Subsea tools are safe and easy to use.

## ON SITE SERVICE

### Hydraulic Torque Wrench



Comprehensive range of hydraulic torque wrench equipment for tightening and loosening bolts.

PT.Hydra Asia Energy services have been experience and solution to any industrial bolting problem, Hydraulic torque wrench ideal for break-out and make-up of bolted joints, with output torque capacity up to 45,000 lbf.ft.



### Hot Bolting

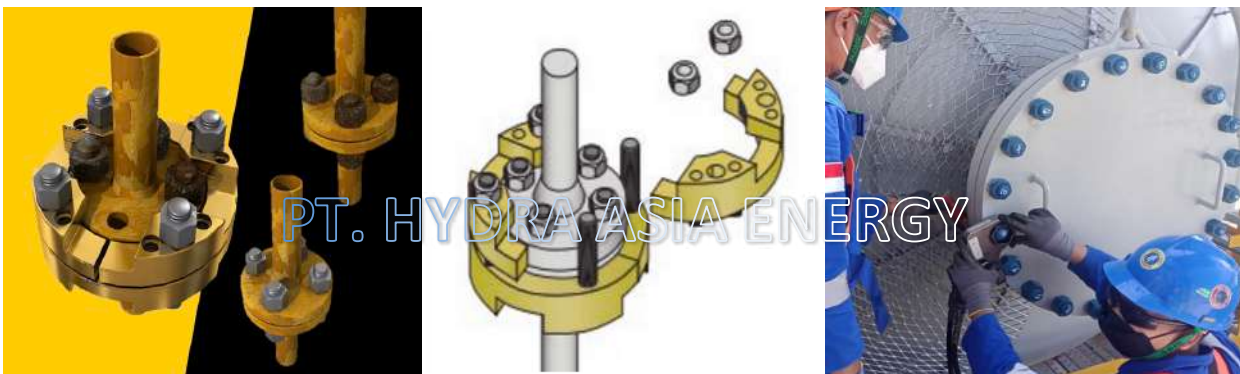

Hot bolting is a term used to describe the technique of re-tightening or replacing flange connection bolts when a pipe is live – (full of liquid or gas). Benefits of Hot Bolting (Single Stud Replacement) : Allows damaged or corroded bolts to be replaced, prevents unplanned shutdown, increases safety, helps towards improved joint integrity, reduces duration of shutdown, limits the number of 'containment breaks, increases efficiency, replaces 'old for new' bolts before shutdown, and reduces costs.

## ***ON SITE SERVICE***

### ***Pipe Cutting ( Cold Cutting and Beveling )***



Portable pipe cutting machines designed for on-site precision severing, severing/beveling and severing/ double beveling. PT.Hydra Asia Energy pipe cutting machine operated by our high experience technician.

### ***Subsea ( Pipe Cutting and Beveling ) Subsea Diamond Wire Cutter***



The pipe cutting machines was two type motor driven, By pneumatic and hydraulic pump. For pneumatic pump usually used on top side and hydraulic pump used in under water (Subsea).

Subsea Diamond Wire Cutter is operated with a hydraulic motor and hydraulic control panel

## ***ON SITE SERVICE***

### ***Hydraulic Flange spreader***



Flange Spreaders separate flanges safely and easily without hammering. The Spreader, which attaches to the flange holes, spreads the flange faces without damaging flange sealing surfaces. In industrial mechanical and hydraulic spreaders feature an integrated wedge concept: Friction-free, smooth and parallel wedge movement eliminates flange damage and spreading arm failure. For maintenance, commissioning, shutdowns, testing and valve change outs Unique interlocking wedge design - no first step bending and risk of slipping out of joint.

### ***Hydraulic Nut splitter***



Nut Splitters are sized according to the nut Sizes they are designed to split. This size can be given as either the measurement across the nuts flats, in either metric or imperial measurements, or the bolt size.

#### **Standard Features :**

No spark or flame, No risk to volatile surrounding, Triangular Chisel providing three cutting edges, Light and compact design for ease of operation and handling, Dedicated cylinder with minimal stroke for faster operation, Calibrated system. No damage to stud / bolt threads and 700 bar working pressure.



## **ON SITE SERVICE**

### ***In Line Isolation and Weld Test Plug***

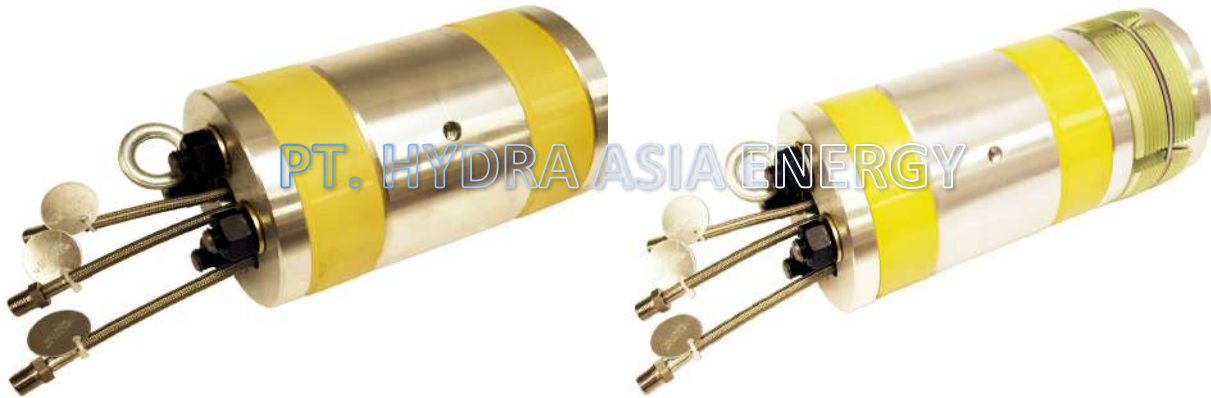

Aluminum/Steel Construction - reduces weight

1.5:1 Safety Factor

Reduces NDE

Uses less than a gallon of water, reducing waste and treatment expense

Working Pressures to 2,250 PSI (155.2 Bar)

Monitor isolation zone and upstream pressure

Sizes 0.75" to 24" NPS, larger sizes available on request

In Line Isolation and Weld Test Plug revolutionizes isolation and testing of pipe connections. The Plug allows an operator to positively isolate and monitor potentially explosive vapors during "Hot Work", then effectively hydrotest the new weld connection with easy to use tool. The aluminum / steel construction makes the tool highly portable and easy to position. The volume of water required for a test is so small that testing can be accomplished using a hand pump. This Greatly facilitates testing in remote areas of the facility.



1.7" TO 84" INFLANTABLE PLUG MEDIUM DUTY PIPE PLUGS WITH AND WITHOUT BY-PASS:

This Inflatable Plug is ideal for insertion through a small opening branch pipe and lower pressure rating and shorter length. This is often the lowest cost solution to plugging large low pressure pipelines. These Plugs may be customized for most pressure, chemical and temperature requirements. Made with ballistic nylon reinforced Nitrile. Standard Pressure range: 3-30 psig



## **PT. HYDRA ASIA ENERGY**

*We offer a comprehensive range  
of quality service, supported by strong,  
experienced engineering teams*



Should have any questions or need assistance, please do not hesitate to contact us for further details Email:

[HAE@cbn.net.id](mailto:HAE@cbn.net.id)

[operation@hydraasia.com](mailto:operation@hydraasia.com)

[saiful@hydraasia.com](mailto:saiful@hydraasia.com)

[laras@hydraasia.com](mailto:laras@hydraasia.com)

website : [www.hydraasia.com](http://www.hydraasia.com)

## Flange Management Equipment



Bolt Tensioning



Subsea Bolt Tensioning



Hydraulic Torque Wrench



Hydraulic Flange Spreader



Hydraulic Nut Splitter



Flange Alignment



## **PT. HYDRA ASIA ENERGY**

[www.hydraasia.com](http://www.hydraasia.com)

**Head Office** : Commercial area, Fatmawati Festival  
Blok B5, Jalan RS.Fatmawati - Cilandak  
Jakarta 12430 Indonesia

Phone : +6221-7501166 , 7514280

Email : HAE@cbn.net.id  
operation@hydraasia.com  
saiful@hydraasia.com  
laras@hydraasia.com

**Warehouse** : Pergudangan Bizhub Serpong,  
Integrated Commercial Estate, Blok GI No. 07  
Jl. Raya Puspitek, Gunung Sindur  
Bogor 16340 - Indonesia

**Brunei Darussalam Office** : Block 3, B10, Complex Pekan Belait,  
Kuala Belait,  
Brunei Darussalam