

air365 Max

VARIABLE REFRIGERANT FLOW SYSTEM
HEAT PUMP & COOLING MODEL

Cooling & Heating



NEW
2024

Johnson Controls-Hitachi Air Conditioning India Limited

HEAD OFFICE & WORKS

Hitachi Complex, Karan Nagar, Kadi,
Distt.- Mehsana - 384440, Gujarat, India.

Email: sales@jci-hitachi.com
Website: www.hitachiaircon.com/in



Call: 079-7141-4848 (Landline)
Mobile/WhatsApp: 756788-4848
E-mail: customercare@jci-hitachi.com

REGISTERED OFFICE

9th Floor, Abhijeet - I, Mithakhali Six Roads,
Ahmedabad - 380 006, Gujarat, India.



This is an e-waste product and should not be mixed with general household waste at the end of its life. For more details, kindly visit our website or contact Hitachi Dial-a-Care.

T - +91-79-26402024
CIN No. L29300GJ1984PLC007470

Join us at: <https://www.facebook.com/HitachiHomes/> <https://twitter.com/HitachiHomes> <https://www.youtube.com/c/HitachiCoolingHeatingIndia> <https://www.linkedin.com/company/johnson-controls-hitachi-air-conditioning>



Live Chat at www.hitachiaircon.com/in



Hitachi India Customer Care



Available on the App Store



Customer Care 756788-4848

The product specifications may change without prior notice to allow Johnson Controls-Hitachi Air Conditioning India Limited to incorporate the latest innovations for its customers. The information/recommendations contained in this catalogue are merely suggestive. Johnson Controls-Hitachi Air Conditioning India Limited declines any responsibility in the broadest sense, for any loss/damage, direct or indirect, arising from the use and/or interpretation of the recommendations in this catalogue. Reference to cooling capacity in TR or Tr. is in general parlance for Tonnage Class only. For exact cooling capacity in Watts, kindly refer specifications sheet.

For further details on T&C and disclaimer in the entire brochure please refer to our company website.

Discover Hitachi Cooling & Heating products accompanied by best service at your nearest dealer/retail outlet.

December 2024



Index

03

Message

11

Outdoor units

15 | End-to-end solution

39 | Outdoor unit line up overview

53

Indoor units

59 | Ceiling Cassettes

67 | In-ceiling cassettes & Concealed

70 | Exposed

79

Ventilation

83 | Ventilation Solutions

85 | Dx-kit

87

Controllers

89 | Centralized controllers

95 | Individual controllers

102 | Accessories

103 | H-link



The beauty of balance

No matter what the weather is like outside, when you're indoors, you want to have complete control over your environment. At work or play, awake or asleep, you're free to create your own atmosphere; balancing energy with calm, sound with silence and light with shade. It's the same for cooling and heating.

When the air around you is in balance, you can enjoy life indoors that much more.

Air. It's a wonderful thing.

Invisible, silent and life-giving, air makes our entire world possible. It surrounds us, continuously energizing, cooling and warming. It can be unpredictable and sometimes challenging, but when air is in harmony with us, everything seems that much easier.

This is our vision.
To create the air that makes life better.



Living Harmony

At Hitachi Cooling & Heating we like to think of this as creating harmony with your interior environment. When we achieve that wonderful balance, productivity, learning, happiness and health can thrive.

We call this 'Living Harmony' and it's at the center of everything we do.



The future together

Living Harmony puts people first. By balancing the human needs of our customers with an uncompromising approach to innovation and quality, we can continue to create the technologies for a more comfortable and balanced world.

Your world. We live in it together.



Adapted to your spaces



Office



FLEXIBILITY

- A COMPLETE solution for whole office spaces; Large ESP Ducted IDU or AHU integrated to VRF for large entrance & conference room, Ventilation units and VRF indoor units for any working space
- Any shape of buildings including high-rise one can be suitable for VRF unit, with max 110m height difference & total 1,000m piping length availability

SUSTAINABLE GROWTH

- Highest EER max up to 5.50 & specially optimized operation for part-load operation thanks to SmoothDrive 2.0 technology
- Smart monitoring and control: to cut the wasteful energy consumption by each checking status of units from airCloud Pro anywhere anytime

WELL-BEING

- Right temperature & right feeling of airflow with multiple comfort features based on reliable occupant sensing and other integrated intelligent features.



Hotel



FLEXIBILITY

- Compact yet powerful cabinet of modular combination capability is SPACE-SAVING solutions, enabling placement on anywhere and transportation can be easier
- Higher flexibility of piping length can help ODUs installed all in one place so that whole installation cost can be decreased & for maintenance ease & less indoor noise bothering

SUSTAINABLE GROWTH

- Less is More!: thanks to max 200% IDU combination capacity, purchase fewer ODUs is okay!
- Efficiency designed-in; Highest EER max up to 5.50 + with other intelligent operations (Auto-Save or Setback function) + SmoothDrive 2.0 technology optimizing part-load smooth operation leading to better and lower running cost!
- Thanks to airCloud Tap (installation & service support app), you can minimize the time and cost for VRF configuration and regular maintenance

WELL-BEING

- Right temperature & right feeling of airflow with multiple comfort features based on reliable occupant sensing and other integrated intelligent features.



School



FLEXIBILITY

- Quicker installation can be achieved by 1. large-capacity yet smaller-footprint and lighter weigh outdoor units 2. both H-LINK & airCloud Tap features can help installers work quickly and efficiently within the limited time (like off-school time on weekends)
- Several types of IDUs to meet any type of application or room shapes for easier installation and better cost-performance balance.

SUSTAINABLE GROWTH

- Help decrease the running cost thank to 1. Highest EER max up to 5.50 & 2. specially optimized operation for part-load operation by SmoothDrive 2.0 technology
- "Individual controller LOCK mode" for safer operation which prevents inappropriate operation by young students.
- Smart monitoring and control: to cut the wasteful energy consumption by each checking status of units from airCloud Pro anywhere anytime

WELL-BEING

- Right purity: Integrate ventilation solutions and enhanced filters to improve indoor air quality.
- Easy removal of air filters in each indoor unit for the quicker and regular cleaning to keep your air conditioner clean



Hospital



FLEXIBILITY

- Quicker installation can be achieved by 1. large-capacity yet smaller-footprint and lighter weigh outdoor units 2. both H-LINK & airCloud Tap features can help installers work quickly and efficiently, so that installation work won't cause troubles to the patients
- Flexible combination available with AHU or Ventilation units integrated to VRF system to minimize your initial cost

SUSTAINABLE GROWTH

- Highest EER max up to 5.50 & specially optimized operation for part-load operation thanks to SmoothDrive 2.0 technology
- Smart monitoring and control: to cut the wasteful energy consumption by each checking status of units from airCloud Pro anywhere anytime

WELL-BEING

- Right temperature & right feeling of airflow with multiple comfort features based on reliable occupant sensing and other integrated intelligent features.

Adapted to everyone's needs

Features, advantages and benefits at a glance

This table sets out the features and benefits of the air365 MAX range with your needs in mind.



For Architects

Those who design the building

EASY TO WORK WITH

Optimize your building by freeing more space from ODU occupied area for the greenery or solar-panel

DESIGN

- Large capacity yet smaller-footprint units (1.2m² for 28HP)
- Require fewer ODUs by IDU connection ratio up to 200%
- Move ODUs to indoor spaces for better building aesthetics
- One solution that works in all ambient conditions

INCREDIBLE ENERGY EFFICIENCY

Achieve the green building certification by our air365 Max latest cabinets

- Lowering direct environmental impact with air365 Max solution
- One of the world's most efficient VRF solutions: high EER/COP up to EER5.50
- SmoothDrive 2.0 confirmed for 39% less energy-consumption at 33% part load operation
- Uses 10% less refrigerant in average
- Demand control operation available to achieve forcible entire power saving



For System Designer (Contractor or Consultant)

Those who design the HVAC solution

EASY TO WORK WITH

Make your offering more attractive than ever from both initial cost and running cost perspective, by our Easy-to-Work solutions

DESIGN

- Design faster with airCloud Select
- Large capacity yet smaller-footprint units (1.2m² for 28HP)
- Require fewer ODUs by IDU connection ratio up to 200%
- Move ODUs to indoor spaces with EPS up to 80Pa
- One solution that works in all ambient conditions
- Max 200m piping length & max 110m height difference flexibility
- Widest choice of IDUs for any shape of rooms

INSTALL

- Less communication wiring with H-Link
- Less configuration time by airCloud Tap
- Easier & lower delivery cost by large capacity yet smaller-footprint cabinet

OPERATE

- Easy for building managers to operate, schedule and automate whole VRF system with airCloud Pro anytime & anywhere
- Easy operation for any end-users by multiple design award-winning remote controllers with user-friendly UX/UI

MAINTAIN

- Anti-corrosion & gecko-proof cabinet available as options
- Automatic reduction of the risk of failure by compressor rotation control
- Even in case of failure, emergency operation mode backs up
- Patented oil-return control technology leading to more reliable yet comfortable operation
- Quicker and easier maintenance work thanks to airCloud Tap

INCREDIBLE ENERGY EFFICIENCY

Meeting the top-priority requirement "energy efficiency" of your end user in both rated & part-load operation

- One of the world's most efficient VRF solutions: high EER up to EER5.50
- SmoothDrive 2.0 confirmed for 39% less energy-consumption at 33% part load operation
- Uses 10% less refrigerant in average

*For above 130% IDU connection ratio, kindly contact the technical team.



For Installer

Those who install & service the solution

EASY TO WORK WITH

Significantly upgraded ease of installation & maintenance by our proprietary technology and solutions

DELIVER

- Easier delivery and unloading with reduced ODU footprint and forklift support point

INSTALL

- Less communication wiring with H-Link
- Easier & lower delivery cost by large capacity yet smaller-footprint cabinet
- Unit base holes for safer installation with equipments and piping works
- 4 directions with 9 options for piping connection
- Significantly easier and quicker configuration for both outdoor units & indoor units by airCloud tap of copy-paste setting features

COMMISSION

- Quicker and easier commissioning, by Service Checker, since it can download continuous operation data for the whole VRF system all at once and create a commissioning report easily

OPERATE

- Intuitive simplicity designed-in Centralized Controllers airCloud Pro for your easier and quicker operation in case of necessity.

MAINTAIN

- Significantly faster access to operational data by airCloud Tap without opening the front-cover cabinets



For End Customer (Investor/Owner)

Those who pay for the system

SEAMLESS COMFORT

From small spaces to the largest buildings, your preferred living harmony are created

- SmoothDrive 2.0 to keep the constant indoor temperature
- Low-Noise operation available for less trouble to the neighborhood
- Smart Changeover for the fair indoor environment cooling and heating by 3 different voting system
- Smart Defrosting & Networked Smart Defrosting for better and constant indoor heating situation

INCREDIBLE ENERGY EFFICIENCY

Reward you with superior performance as well as significant energy and cost savings

- Lowering direct environmental impact with air365 Max solution
- One of the world's most efficient VRF solutions: high EER up to EER5.50
- SmoothDrive 2.0 confirmed for 39% less energy-consumption at 33% part load operation
- Uses 10% less refrigerant in average
- Demand control operation available to achieve forcible entire power saving

EASY TO WORK WITH

Less stress and less expense by our user-friendly controllers and applications

OPERATE

- Easy for building managers to operate, schedule and automate whole VRF system with airCloud Pro anytime & anywhere
- Easy operation for any end-users by multiple design award-winning remote controllers with user-friendly UX/UI

MAINTAIN

- Significantly faster access to operational data by airCloud Tap without opening the front-cover cabinets

OUR MILESTONES

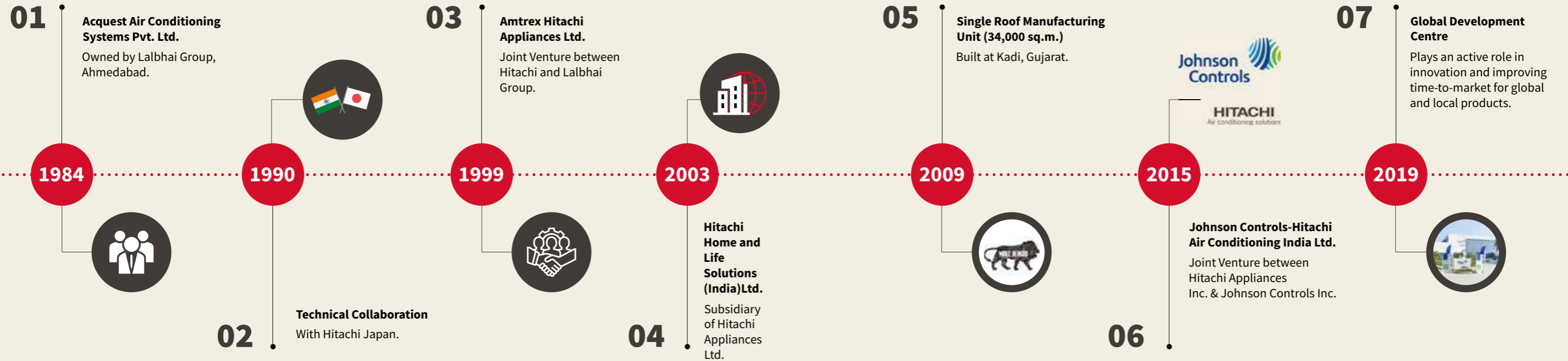

State-of-the art facility at Kadi, Gujarat

HIGHLIGHTS

- One of the Biggest Single Roof Facility of 34,000 sq.m.

OUTDOOR UNITS

15 End-to-end solution

- 16 Best-in-class efficiency
- 16 Easy to work with
- 16 Seamless comfort

17 Boost your energy efficiency

33 Enjoy the perfect air anywhere, anytime

39 Outdoor unit line up overview

41 Specifications

55 Option / Accessories

End-to-end solution

For HVAC professionals, architects & building owners looking for a modern HVAC solution that is cost efficient and adaptable, air365 Max is an end-to-end solution that's easy to work from design to installation, operation and maintenance, offering incredible energy efficiency and seamless comfort for users



Technology

SmoothDrive technology

Hitachi's direct capacity control technology utilizes precise temperature monitoring and control of scroll compressor frequency to reduce compressor on/off cycles and improve temperature stability under part-load conditions. Up to 39% more efficient under the part-load conditions that regulatory energy efficiency ratings do not account for.

airCloud Tap + NFC technology*

airCloud Tap app, designed for installers and service engineers enables 4X faster configuration of outdoor units and 6X faster data checking via a smartphone, and removes the need to open the outdoor unit cabinet. Simply 'tap' a smartphone on the outside of the unit, and configure everything inside the app.

Gas-injection Scroll Compressor

With 10 to 140rps (by 0.1Hz step) driven by DC inverter motor, our gas injection Scroll Compressor extends compressor operating range and increases heating/cooling capacity, leading to a wider outdoor unit operating temperature range & better efficiency. Other proprietary technologies in our latest Scroll Compressor include an internal oil circulation structure and intermediate gas pressure structure, contributing to the best balance of performance and reliability.

Oil-return technology

As well as reducing lubricating oil loss, this patented oil return control cycle consumes less energy and produces much less noise—resulting in higher efficiency and greater comfort for occupants

- Every hour, oil-return operation activates for just 60 seconds (cooling mode) / 120 seconds (heating mode)
- During oil return mode, indoor units can continue to operate normally

Smart Defrost

For Heat Recovery and Heat Pump types:
 Defrosting frequency shortened by 2X for single ODU configurations
 Operate in up to -25C ambient
 Defrosts the ODU in cold temperatures while minimizing the resulting downtime of the indoor units
 Patented intelligent sensing technology detects when defrosting is required and instantly adjusts the exterior case temperature to eliminate ice and frost, so that it can reduce frequent and unnecessary defrosting operation.
 Defrosting frequency reduced by more than 50%, requiring a defrosting cycle as little as every 250mins

Patented Sigma-shape with patented path structure

Σ shape!

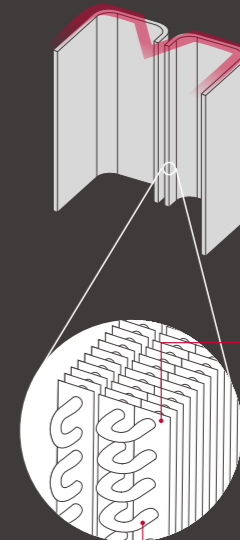

Our proprietary sigma-shaped (Σ) heat exchanger has around 6000 pieces aluminum fins as thin as of 0.1mm and characterized with its complicated surface to expand heat-transfer area. Around 350 copper tubes with special inner structure, and a new 3-way path structure which expands the heat-transfer area and efficiency enormously.

Plate Fin

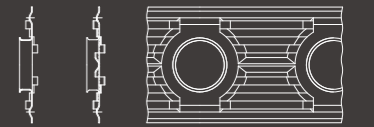

Tube



Spiral shape inside the tube

Strong structure Resistant up to 60m/s (134mph)

Increased rigidity in the front and back of the frame reduces the possibility of damage from external impacts & supports reliable operation even under super windy weather up to 60m/s (134mph) which is enough strong to collapse the wooden houses.

*It is an optional feature.

End-to-end solution



1 Best-in-class efficiency

Offers significant improvements in energy consumption thanks to the higher EER & SmoothDrive technology which helps to reduce running costs during part-load operation. This can lead to reduced CO₂ emissions for customers as well.

5 key claims

- ✓ All-new heat exchanger and gas injection scroll compressor enables best-in-class VRF energy efficiency up to EER 5.50
- ✓ **(Original)** SmoothDrive 2.0 confirmed for 39% less energy-consumption at 33% part load operation
- ✓ Uses 10% less refrigerant in average
- ✓ Demand Response Enabling Device (DRED) support through both remote controller & centralized controller
- ✓ Reduce energy consumption and carbon footprint by 47%

2 Easy to work with

A complete solution that saves time and money at every stage of your project, from Design to Maintenance. Our complete ecosystem of indoor & outdoor units, smart apps and hardware features work together as a complete solution.

6 key claims

- ✓ [Design] User fewer ODUs with single unit capacity up to 28HP and 200% IDU connection capacity
- ✓ [Deliver] Load up to 14% more AC capacity in a single vehicle
- ✓ [Install] **(Original)** Up to 4X faster configuration of units with airCloud Tap
- ✓ [Commission] Quicker & easier commissioning with Service Checker - get instant reports and visualize detailed operational data
- ✓ [Operate] Easy monitoring by airCloud Pro anytime anywhere
- ✓ [Maintain] **(Original)** Fast access to error data by using airCloud Tap

3 Seamless comfort

Seamless comfort for building occupants, anywhere, anytime. Solves common problems of HVAC solutions including unstable temperatures, cold or hot drafts, direct air, hot and cold rooms during season changes, and more.

4 key claims

- ✓ **(Original)** Constant indoor temperature even during part-load operation with SmoothDrive 2.0
- ✓ Neighborhood-friendly outdoor unit with 3dB(A) lower noise output in average by Night Shift Mode in average

* For above 130% IDU connection ratio, kindly contact the technical team.

Boost your energy efficiency

With air365 Max, discover how you can make significant improvements in your energy consumption fee.

High efficiency ratio

• Best-in-class efficiency up to **5.50** EER

All-new heat exchanger and gas injection scroll compressor enables best-in-class VRF energy efficiency
By installing air365 Max, and you can realize significant energy savings.

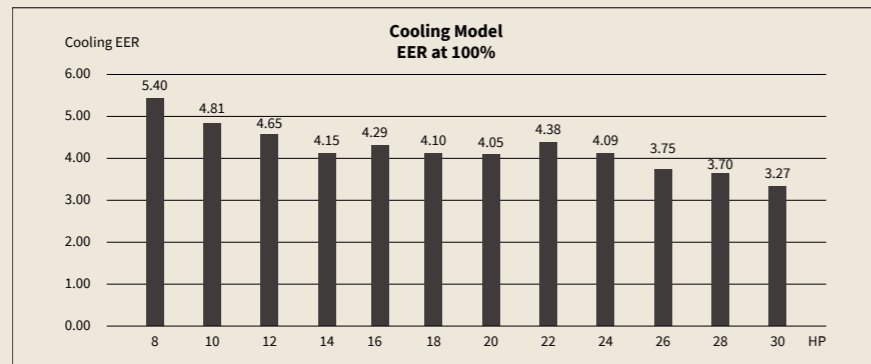
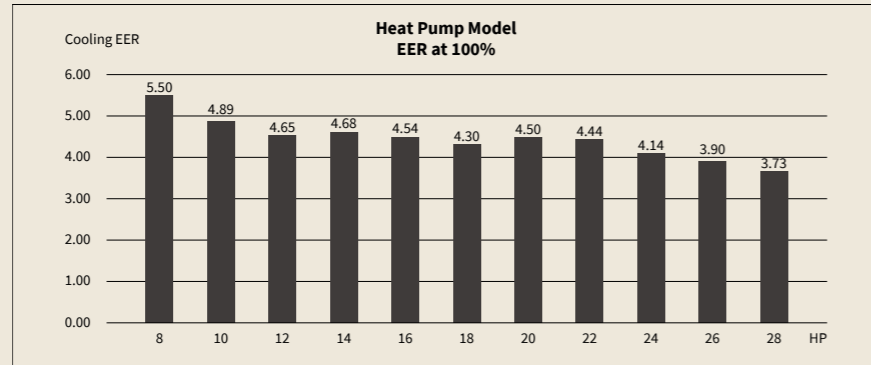

NOTES:
The graphs above show the EER of single units in combination with specified indoor units. T&C apply.



Ideal for Renovation Projects

• Reduce energy consumption and carbon footprint by 47%*

Our technology is improving every year.
Replace outdated HVAC solutions and achieve a 50% reduction in energy consumption and carbon footprint*

Electricity consumption reduction

Comparison of (for a system equivalent to 10HP class (28.0kW))
Between [RAS-FSN Hitachi inverter VRF of 15years ago]
VS [air365 Max RAS-HNCC**]

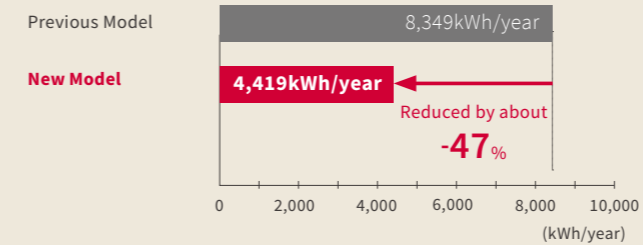

CO₂ emission reduction

CO₂ emissions
(for a 10HP class (28.0kW) equivalent system)

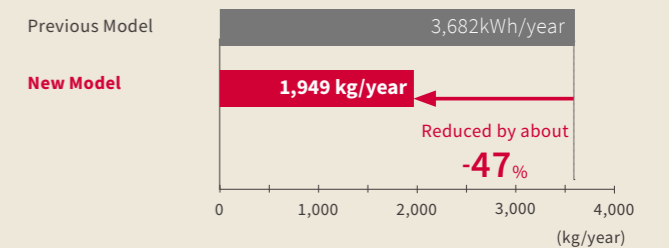

NOTE
Condition:
1. Both simulation of Seasonal power consumption & CO₂ emissions are a trial calculation value based on JIS B 8616: 2015 (Tokyo office).
(cooling: Apr-19 to Nov-11)(Heating Dec-3 to Mar-15)
(District: Tokyo) (Application: Office)
(AC usage: 6days per week, 8am to 8pm)

2. The CO₂ emissions coefficient is 0.441 kg-CO₂ /kWh. Based on Electric Power Industry Council for a Low Carbon Society in FY20
3. As reference in Japanese domestic model

Less refrigerant required

• Uses 10% less refrigerant in average*

Compared with our previous generation VRF product air365 Max uses 10% less refrigerant in average & 14.6% less in maximum, helping to reduce the environmental footprint and maintenance costs.

Comparison of (for a system equivalent to 16HP class (45.0kW))
Between [RAS-FSNS previous model VRF of 5years ago] VS [air365 Max RAS-HNCC**]

System	Previous top flow VRF	air365 MAX
Initial charge	9.9kg	9.5kg
Additional charge	14.5kg	13.0kg
Total	24.4kg	21.5kg

-12% refrigerant* used!

* Simulation condition; Comparison between Single 8-28HP class (tier 2) under 95% connection ratio

** Condition:16HP class ODU (45.0kW) *1
3HP class IDU (8.0kW) * 5
Total piping length; 120m
IDU connection ratio: 89%

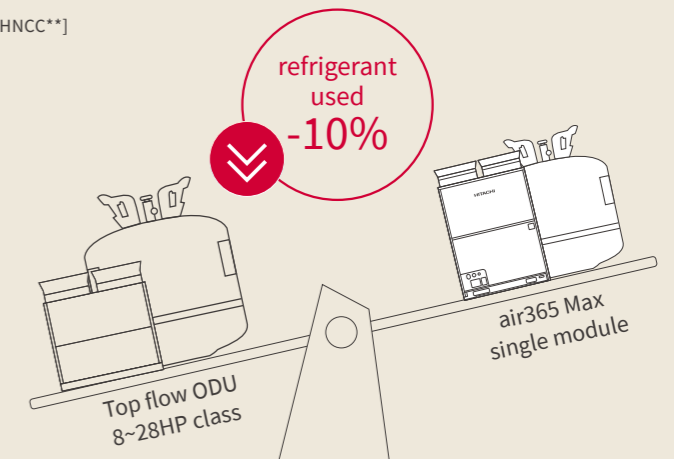

SmoothDrive™ 2.0 : Superior compressor control

· Verified 39% less energy-consumption at part-load operation

Most of the time HVAC systems are under part-load because of ambient conditions, set temperature, occupancy and over-specification of the system. As organizations look to improve energy efficiency and reduce carbon footprint by mandating set temperatures within a reasonable range, part-load becomes even more important. Hitachi air365 Max utilizes direct capacity control which combines accurate temperature sensing with precise compressor control to balance load and capacity with less fluctuation. And its effect on energy consumption is verified formally at 3rd party testing facility.

<Testing Condition>
 (at Cooling Operation, Load Factor: Approx. 33%)
 Without SmoothDrive; average power consumption 2.46kW
 With SmoothDrive; average power consumption 1.49kW

VRF ODU: (RAS-AP280DG3 = RAS-10FSNS)
 VRF IDU: 4-way cassette indoor units (RCI-AP140K5 = RCI-5.0FSRP)
 Indoor Unit Inlet Temperature: 27°C (Dry Bulb) / 19°C (Wet Bulb)
 Ambient Temperature at Air Volume "High": 23°C (Dry Bulb)
 Piping Length between Indoor Unit and Outdoor Unit: 15m
 Testing Location: Environment Testing Facility at Kansai Denryoku (power supply company)

VRF air conditioners in buildings experience all kinds of changes during the day...

People coming and going...

Changes in outdoor weather conditions...

Variations in temperature preferences...



This causes VRF systems to operate at partial load

More than 70% of the time during a year, a VRF System will be running under part-load conditions, with most systems operating at 50% or less of their capacity*1. These unpredictable part-load conditions cause real-world performance to deviate significantly from official published energy efficiency data.

It's a key reason why your customer may not fully experience all the energy savings they expected from new equipment.

AC operating hours per outside ambient temperature in Office (Japan, Tokyo) (concerning Large Split & VRF) *1

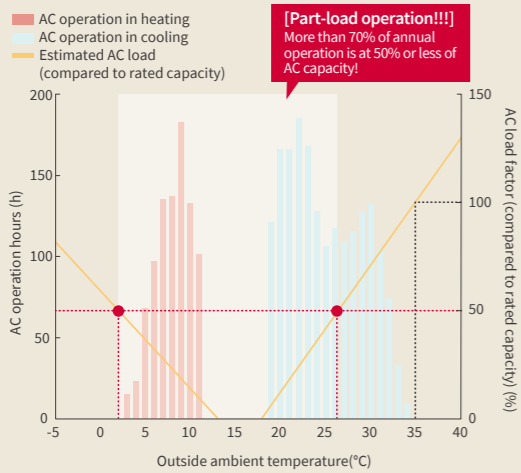

*1. JIS B 8616:2015 (Japanese packaged air conditioners standard) to arrange the performance test for the system.

The simplicity of SmoothDrive

We believe the key to energy efficiency at part load is how generating capacity is controlled. In a normal VRF system this capacity control can be complex, combining both control of refrigerant evaporation temperatures and compressor operation. But at Hitachi Cooling & Heating we've developed a more simple approach called SmoothDrive.

Why SmoothDrive ?

Part-load conditions cause real-world performance to deviate significantly from official published energy efficiency data. Which is why Hitachi's patented direct capacity control technology delivers...



Real-world energy efficiency

Improved energy efficiency under part-load operation, which regulatory energy efficiency ratings do not account for.



Temperature stability

With continuous monitoring and adjustment of the capacity based on compressor speed, indoor temperatures can be maintained more accurately.



Smoother compressor operation

Compressor rotation frequency is more precise and stable. On/Off cycles are reduced, while peaks and drops are diminished, reducing wear on the compressor.



Real-world energy efficiency**

Improved energy efficiency under part-load operation, which regulatory energy efficiency ratings do not account for

COP in Cooling mode

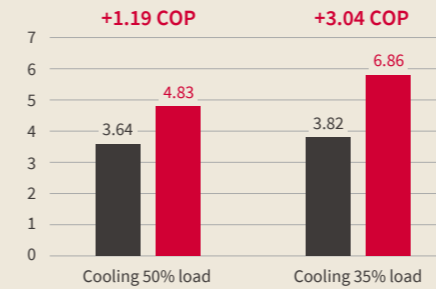

COP in Heating mode

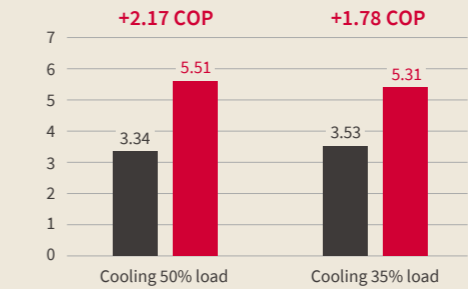

■ without SmoothDrive
 ■ with SmoothDrive

* Averaged power/load are calculated for 5 hours from start
 * COP = Averaged load / Averaged power



Temperature stability**

With continuous monitoring and adjustment of the capacity based on compressor speed, indoor temperatures can be maintained more accurately

Cooling 50% Load

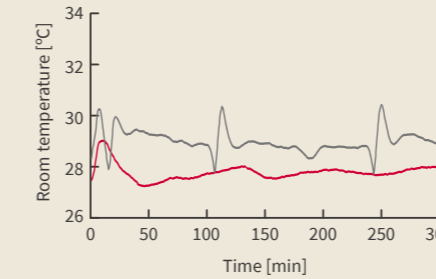

Cooling 35% Load

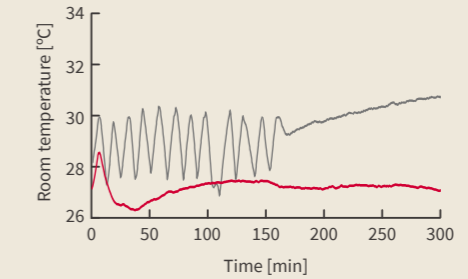

Set temp: 27°C
 Initial IDU temp: 27°C / 19°C
 — Air Inlet temperature of IDUs (without SmoothDrive)
 — Air Inlet temperature of IDUs (with SmoothDrive)



Smoother compressor operation**

Compressor rotation frequency is more precise and stable. On/Off cycles are reduced, while peaks and drops are diminished, reducing wear on the compressor.

Cooling 50% Load

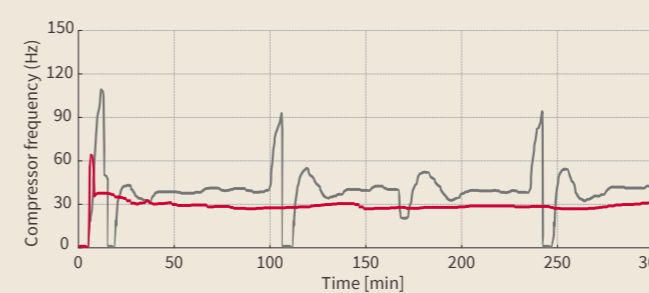

Cooling 35% Load

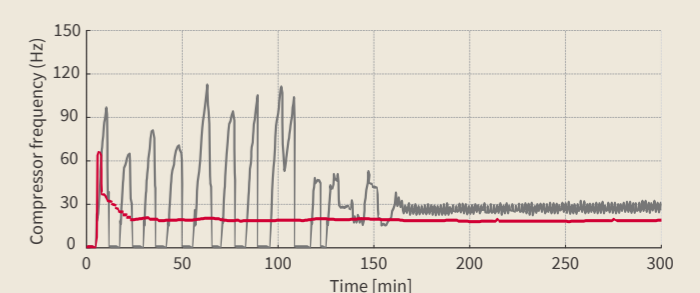

** Outdoor Unit; 10HP class. Indoor Unit: 5HP Class 4-way cassette unit * 2 pcs. In our internal company's fixed-load testing facility (Dimension of the room per one indoor unit: 5.6m x 2.5m x 3.1m). Outdoor temp (DB / WB): 29°C / 19°C. Load per room (Sensible / Latent): 4.9kW / 0.0kW. Set temperature: 27°C. Initial Indoor unit temperature (DB / WB): 27°C / 19°C. Indoor unit fan airflow rate: Hi-mode.

Demand control

- Manage your electricity during peak periods
- Peak-cut Control
- Moderate Control

A Demand Response Enabling Device (DRED) air conditioner allows your electricity provider to control the system at various pre-programmed levels, to manage your demand on the power grid during peak periods.

The aim is to reduce overall power consumption to the supply network at critical peak load times.

This feature can be enabled and disabled on an individual or centralized Hitachi controller. No additional equipment is required.

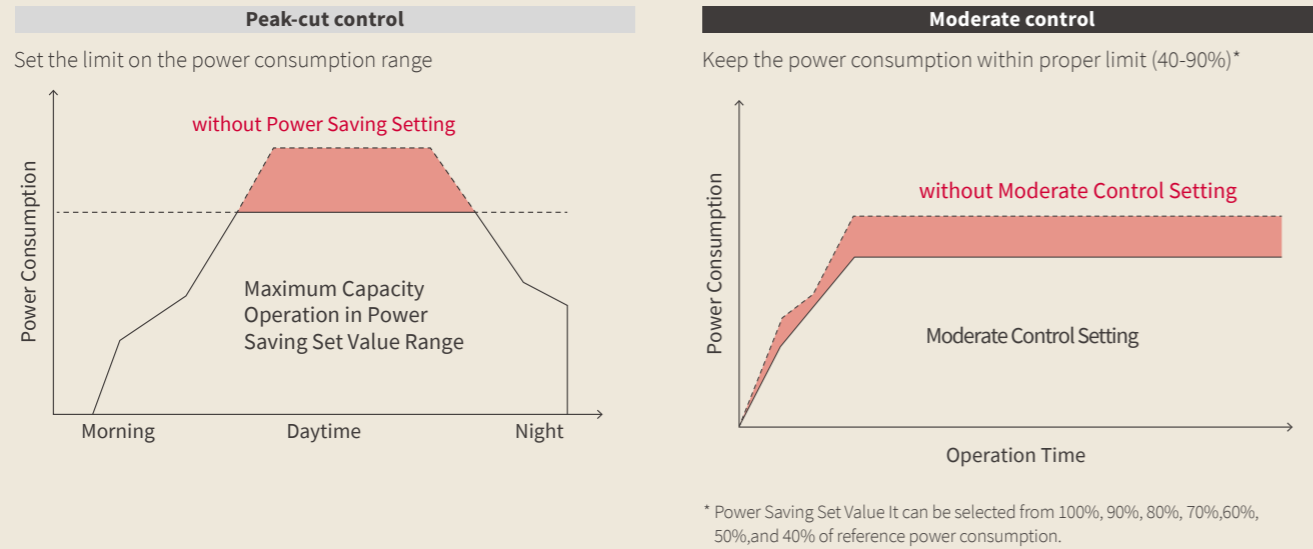

Better energy saving operation (Motion Sensor Control)

- Compatible internal units (IDUs) can automatically detect occupancy and automate operation accordingly

The presence sensor makes it possible to control operation based on the persons present in the climate controlled space. If the VRF unit is installed in a room in which the presence of persons is not constant, the sensor makes it possible to automatically control operation in such a way as to reduce consumption and achieve energy savings.

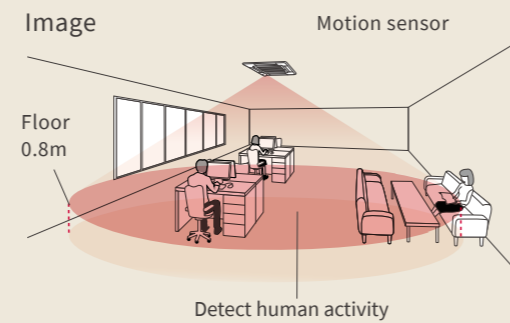

Automatically saves ability by detecting the amount of human activity

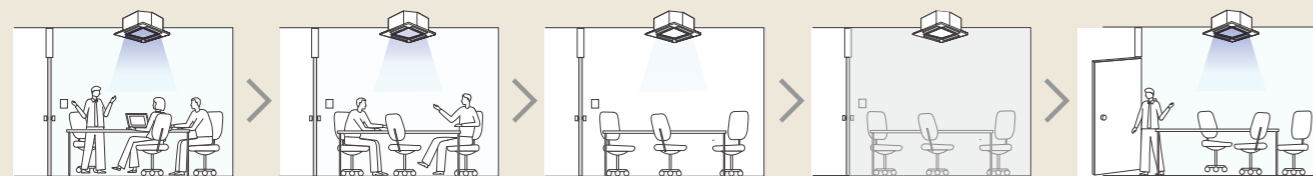

Standard operation

In a room with a lot of people moving, standard operation

Save Power

Moderate air conditioning when there is little movement of people

Save more

When there are no people for a certain period of time, the air conditioning is even more modest

Forgetting to turn off

If the absence continues for more than 30 minutes, the operation can be stopped by setting

Resume

Resume standard operation when people return

Thanks to 200% IDU connection ratio

In case that IDU total capacity are 52HP

Before

2 ODU Operate 12 IDU
(The least ODU you need to purchase was 40HP unit (HNCQ L-size*2))

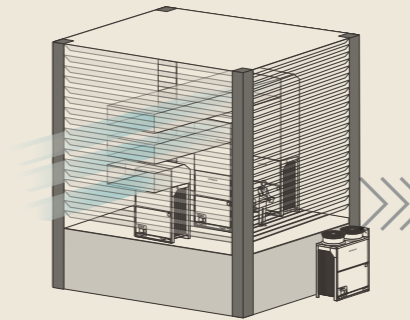

IDU 52HP = ODU 40HP*130%

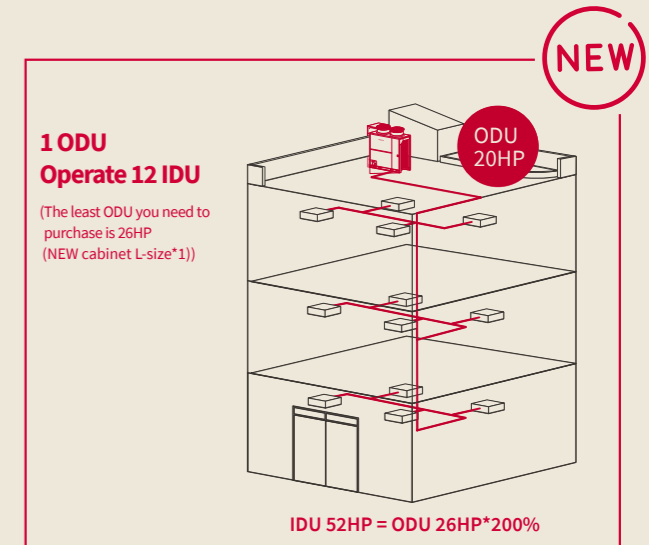

*Above 130% connection ration, kindly contact the technical team.

High external static pressure (ESP)

- Total 4 steps of ESP
- Maximum up to 80Pa

The High External Static Pressure (ESP) setting for air365 Max units enables them to be located inside ventilated machine rooms, rather than just outdoors. This may reduce installation costs as well as reducing impact on the external facade of the building.

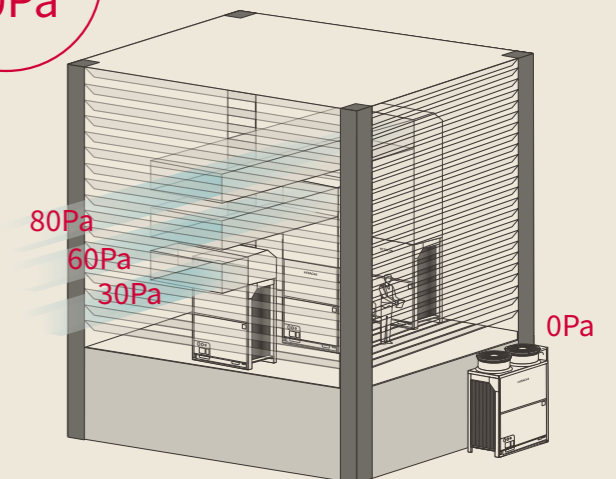

System Design

More flexible piping configuration

- Maximum piping length up to 200m
- Maximum height difference up to 110m

Longer pipe runs and greater height differences enable more flexibility for use in retrofit or renovation projects
 Supports installation in high-rise buildings
 Depending on building design, enables location of all units on the rooftop for faster installation and easier maintenance
 Enables more discrete placement further away from visual and noise sensitive spaces

< For 4 Units Combination >

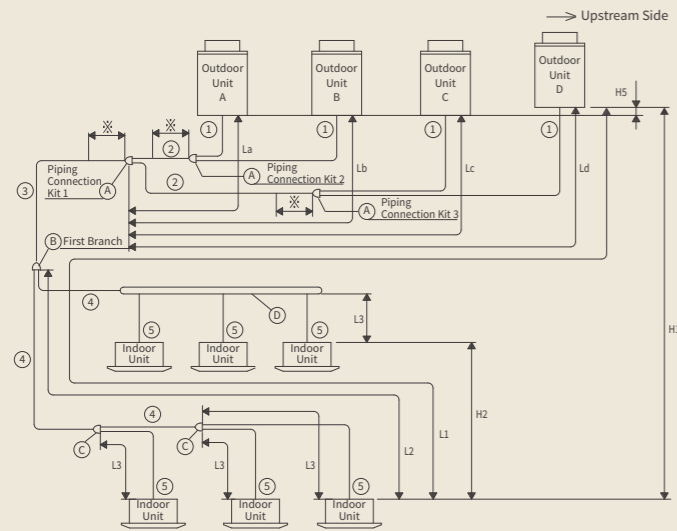

※ Keep the straight line distance of 500mm or more after the piping connection kit.

			Mark		
Total piping length	Between ODU and IDU	Actual	m	1,000	-
		Equivalent	m	225	L1
Maximum piping length	Between "Piping connection kit" and each ODU single module		m	25	La, Lb, Lc, Ld
	Between "1st branch Multi Kit" and farthest IDU		m	100	L2
	Between "Multi Kit" and each connected IDU		m	40	L3
Maximum height difference	Between each single module of 1 ODU		m	2	H5
	Between ODU and IDUs	ODU above IDU (*)	m	110 (50)	H1
		IDU above ODU (*)	m	110 (40)	H2
	Between IDUs		m	40	H2

Note: Some restrictions would be applied when the height difference between outdoor units and indoor units are [50m or more in case outdoor unit is higher] and [40m or more in case outdoor unit is lower]. Please refer to technical manual for details.

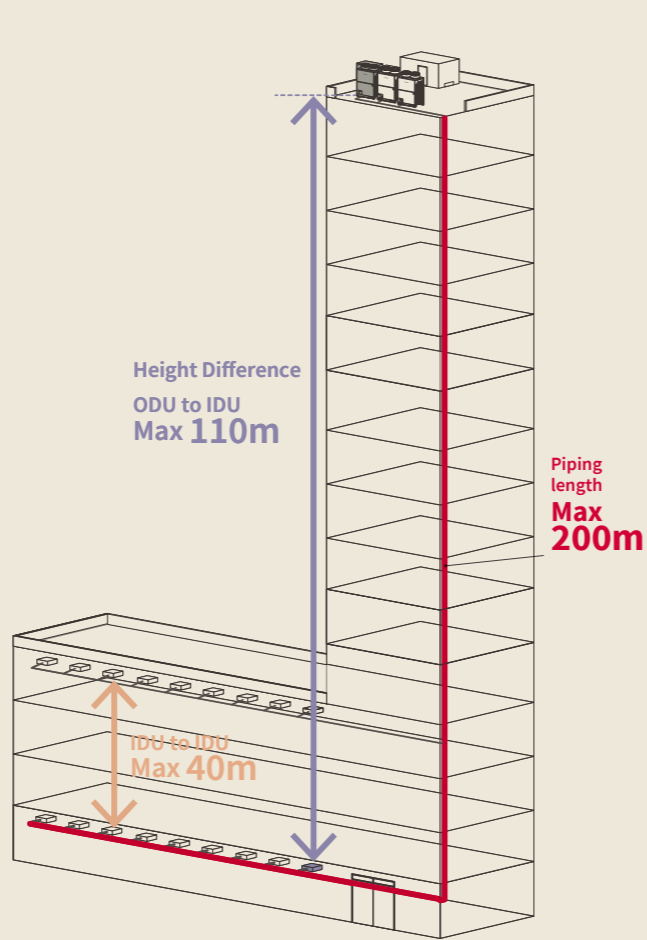

Widest choice of indoor units

- Total 13 types
- Design award winning design

With more than 100 different indoor units to choose, air365 Max supports a wide range of building layouts and interior design requirements
 Includes units that can be hidden to suit indoor aesthetics
 Exposed units that minimize installation costs
 Best balance of cost and aesthetics can be supported by the unique Silent-Iconic 4-way cassette panel



Anytime & Anywhere

- Cooling in 52 ~ -10°C
- Heating in 16 ~ -25°C
- Normal operation even under up to 60m/s
- JRA anti-corrosion treatment available

Because we live in a diverse and changeable world, our air365 Max units are designed to operate faultlessly in any climates and weather situation

Summer temperature

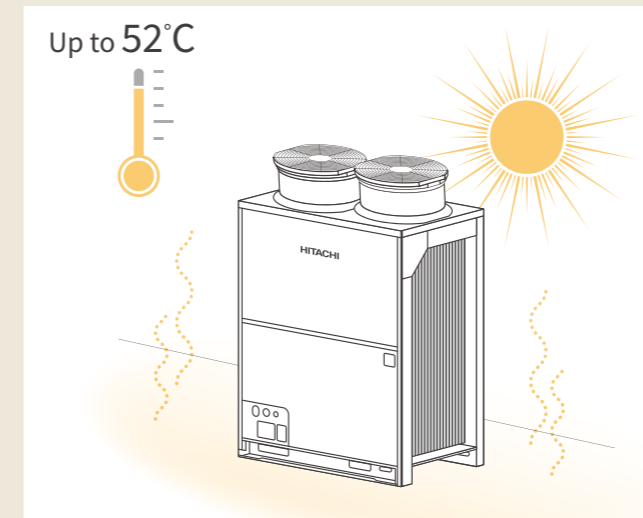

Cooling operation up to 52°C ambient temperature

Winter temperature



Heating operation up to -25°C ambient temperature

Anti-Corrosion Cabinet + Gecko-proof treatment

If your project is located in an extreme weather environment, consider applying an anti-corrosion treatment to your air365 Max outdoor units. Treatment can be arranged in factory based on the JRA9002 standard, with multiple layers on every component of the unit. With this treatment, the life expectancy in marine salty-air environments can be doubled. It is also effective against lizards/geckos.



*Considered JRA9002: Criteria and Testing of Corrosion-proof for Refrigeration and Air Conditioning Equipment against Salty Air
 *Please consult Hitachi distributors for more details
 *Both "Anti-corrosive treatment" and "Heavy anti-corrosive treatment" are by custom order

Corrosion Resistance

Life-expectancy comparison In salty-air-location

Standard	Standard bar	
Anti-corrosive Treatment Custom Order	Longer bar	2 times longer!
Heavy anti-corrosive Treatment Custom Order	Longest bar	2 times longer!

Corrosion-resistance improved Heat Exchanger

3 Coating Layers

- Hydrophilic Resin Film
- Corrosion-Resistance Resin Film
- Phosphoric Acid Chromate Treatment
- Aluminum Fin

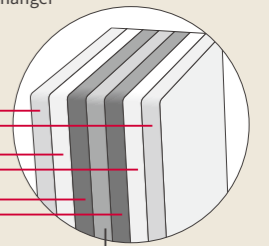

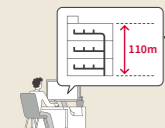

System Design



reddot winner 2022
interface design

airCloud Select

• “airCloud Select” is the new software created by Hitachi to help you quickly finish the unit selection for your VRF design project.

- Enjoy a super intuitive and modern interface
- Select the suitable VRF equipment for each project
- Generate automatic report for your customers

airCloud Select is available upon request. Availability varies per country. For more information, please contact your Hitachi Cooling & Heating representative or visit www.hitachiaircon.com



Choice of piping direction

- 4 directions, 9 options

To make the installation as easy as possible, air365 Max unit can be piped from the front and base of the units via 9 different piping options. Bottom piping connection is large enough for refrigerant piping with standard insulation.

Front

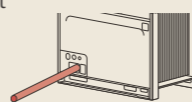

Back

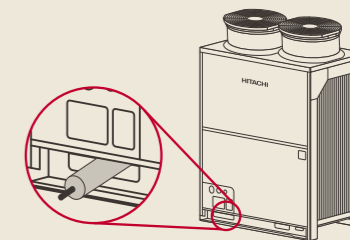
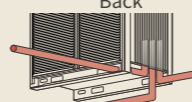

[Front]

- Through the piping port on the front panel cover
- Through the Unit base hole

[To the right]

- Through the piping port on the front cover
- From bottom of the cabinet
- Through the Unit base hole

[To the left]

- Through the piping port on the front cover
- From bottom of the cabinet
- Through the Unit base hole

[To the rear]

- Through the Unit base hole

H-LINK: flexible route of communication wiring

- Faster wiring with H-LINK

Hitachi H-LINK is a powerful, proprietary communication system that lets you control multiple outdoor and indoor units from one control point. For installers and service engineers, H-LINK simplifies the whole building wiring works by enabling units to 'daisy chain' together - making wiring connections from the closest available unit, regardless of the type. This can reduce installation time and costs.

H-LINK

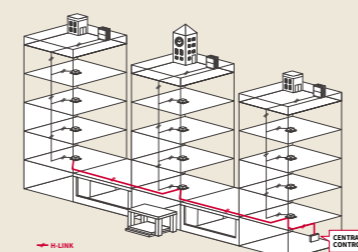

Company A

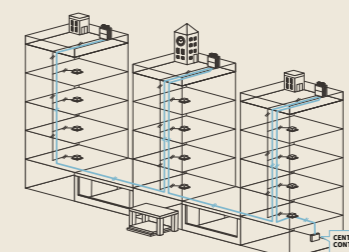

- ODU configuration: 4X faster
- IDU/controller configuration: 2X faster

Faster configuration using our patented airCloud Tap mobile app and NFC (Near-field communication) technology embedded in the outdoor unit and individual controllers. All settings are available with convenient descriptions inside the phone app. Operators can 'copy and paste' settings for one ODU (or IDU via individual controller) to multiple units using their phone. Ideal for hotels, classrooms, businesses with multiple meeting rooms or large buildings with multiple VRF outdoor units installed.

Download
airCloud Tap!



76% time reduction (ODU configuration)

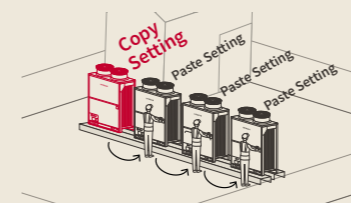

- 1) Conventional way to open and close the cover and manipulate dip/power switch: >>> takes 40min 40sec
- 2) By using airCloud Tap without opening the cabinets: takes 9min 40 sec [Simulation scenario]
 - total 4 ODUs initial setting
 - total 5 items setup; ODU number, Refrigerant cycle number, Higher ESP setting, Power Supply setting, and Compressor manual-off setting.

53% time reduction (IDU + CTRL configuration)

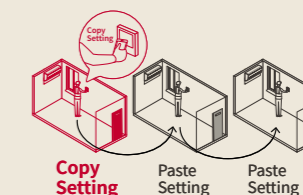

- 1) Conventional way: takes 103min 16sec
- 2) By using airCloud Tap: takes 47min 40 sec [Simulation scenario]
 - Total 20 controller setting
 - Total 7 items of setup: Room name, Time, Language, Temperature unit, Backlight of the screen, Operation schedule from Monday to Friday 08:30-18:30 28°C, Upper and lower limit of setting temperature for both cooling and heating



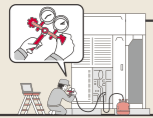

Commission

Service Checker

- Quicker & easier commissioning

Service Checker is a dedicated service device for HVAC technicians. It can connect to the ODU PCB to download continuous operation data for the whole VRF system and create a commissioning report easily.

Key features

- Display and storage of all operation data
- Graphical visualization of operation data
- Rapid report creation
- Access to all unit settings/configuration

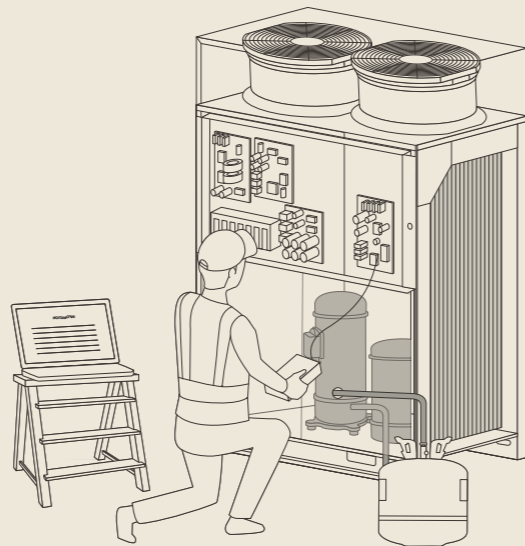



Operation

airCloud Pro

- Control is in your hands. 24/7 control at your fingertips on smartphone, tablet, or PC.



For stand-alone and multi-site applications.

- ✓ **Intuitive simplicity**
airCloud Pro is designed to make your job easier. An intuitive app that anyone can use, airCloud Pro makes managing your VRF systems easier than ever before.
- ✓ **Control from anywhere**
Enjoy the freedom of remote access from your smartphone, tablet or laptop. airCloud Pro allows you to remotely control your VRF system(s) from a single app, saving you travel time.

Individual controllers PC-ARFG1 / PC-ARC



- A new generation of room controllers with User friendly UX/UI

ADVANCED-COLOR CONTROLLER (PC-ARFG2-*)



Complete controls in a rich interface

- Colored screen displaying visual charts and descriptive texts
- Access to all existing Hitachi VRF indoor unit features including user features settings, installation & maintenance features settings.
- Energy consumption monitoring
- Ideal for indoor units with motion sensors, cassettes with elevating grilles
- Multiple languages available



reddot winner 2021



ECO-COMPACT CONTROLLER (PC-ARC-*)



Value without compromise

- Segment screen displaying pictograms
- Essential controls in a glimpse
- On/Off weekly schedule
- Some extra advanced features such as GentleCool, Power-Saving Peak-Cut mode and Sleep Mode Timer
- Embedded IR receiver, ideal for ducted units



Maintenance

Compressor rotation control

- Extend ODU lifecycle

manages equal loading on multi-compressor configurations, ensuring equal lifespan of each compressor in the system

Compressor rotation frequency control (example)

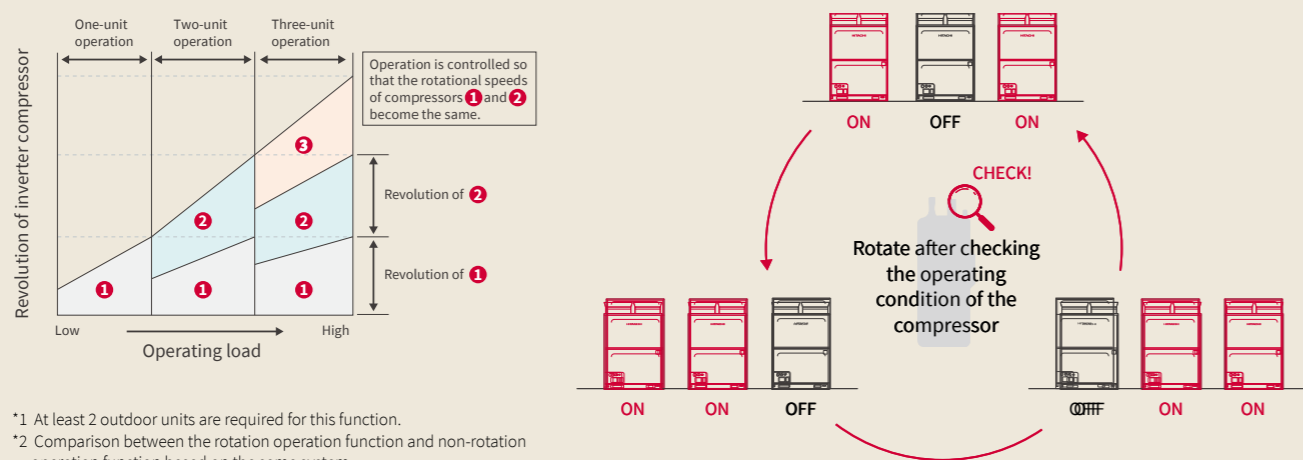

*1 At least 2 outdoor units are required for this function.
*2 Comparison between the rotation operation function and non-rotation operation function based on the same system.

Emergency operation mode

- Continue HVAC operation in the event of a unit failure

In multi-unit installations, the Backup Operation Function prevents the system from coming to a complete stop if an outdoor unit failure occurs. If one outdoor unit should fail, the system can continue to operate using the remaining outdoor units. Emergency operation can be performed up to 8 hours after unit stoppage.

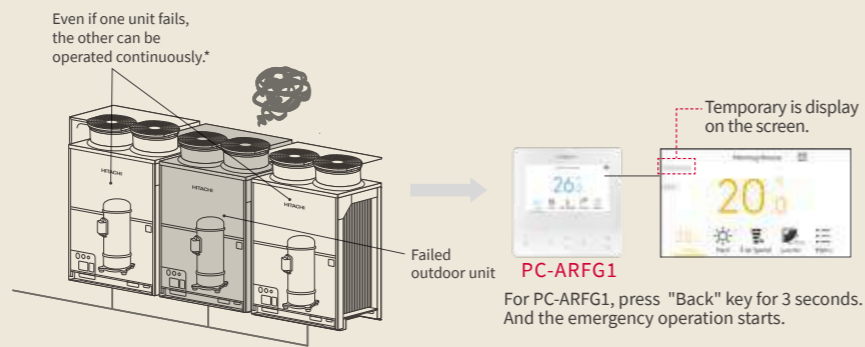

* Emergency operation cannot be performed within 8 hours after unit stoppage.

Oil-return control

- Patented oil control for lower noise and higher energy efficiency

As well as reducing lubricating oil loss, this patented oil return control cycle consumes less energy and produces much less noise—resulting in higher efficiency and greater comfort for occupants

- Every hour, oil-return operation activates for just 60 seconds (cooling mode) / 120 seconds (heating mode)
- During oil return mode, indoor units can continue to operate normally

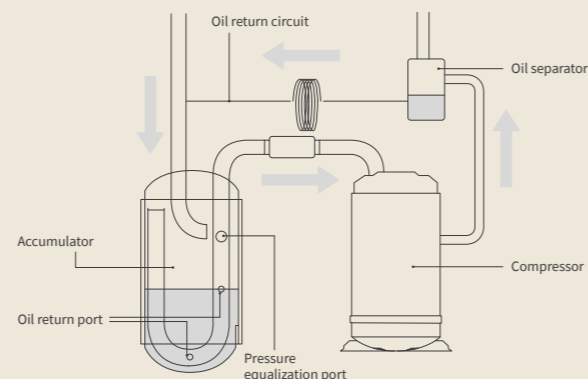

airCloud Tap for faster maintenance



- 6X faster access to unit operational data*
- 80% time reduction (ODU data check)

Previously, a maintenance engineer would need to open both the front panel of the cabinet and electricity box panel, then check error codes on the PCB.

Now with the airCloud Tap app, an engineer can simply 'tap' the outdoor units with their smartphone to access a full range of configuration settings and download operational data if required for basic troubleshooting.

No need to open the panel to check simple data anymore!!!

The technology is also embedded in individual controllers enabling access to indoor unit settings.

Before

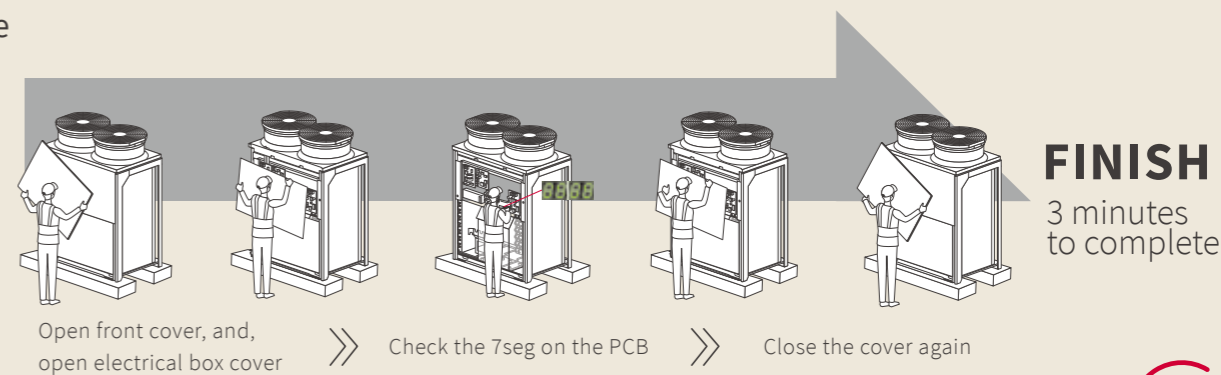

Using the airCloud Tap, operate the app, touch the ODU, and obtain the data >>> total 30sec

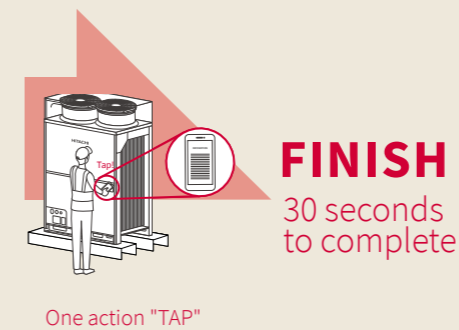

Note.
Test simulation scenario: Check the alarm cause [Previously] open up the cabinet panel, open the electricity box cabinet panel, check the 7segment of the PCB, then, close the two cabinet panels.
>>> minimum takes 3min
[Now] just activate the airCloud Tap application, and, operate the screen, and TAP the outdoor unit and obtain the data >>> takes 30sec!

Powerful support app for your quick configuration & maintenance



Available on the App Store

ANDROID APP ON Google Play



Low Noise Operation

- Neighborhood-friendly outdoor unit with 3dB(A) lower noise output* in average

Balance is the key to harmony, so air365 Max incorporates features to ensure a more peaceful environment, both indoors and out. Enjoy quiet comfort indoors with less disturbance to the outside environment. You can set this feature from your individual controller easily.

#Normal Sound Pressure (SPL) in Full Anechoic VS #Night-shift mode (SPL) in Full Anechoic Average -3.0dB(A)
Reference: Architectural Institute of Japan "Sound insulation performance standards and design guidelines for buildings"

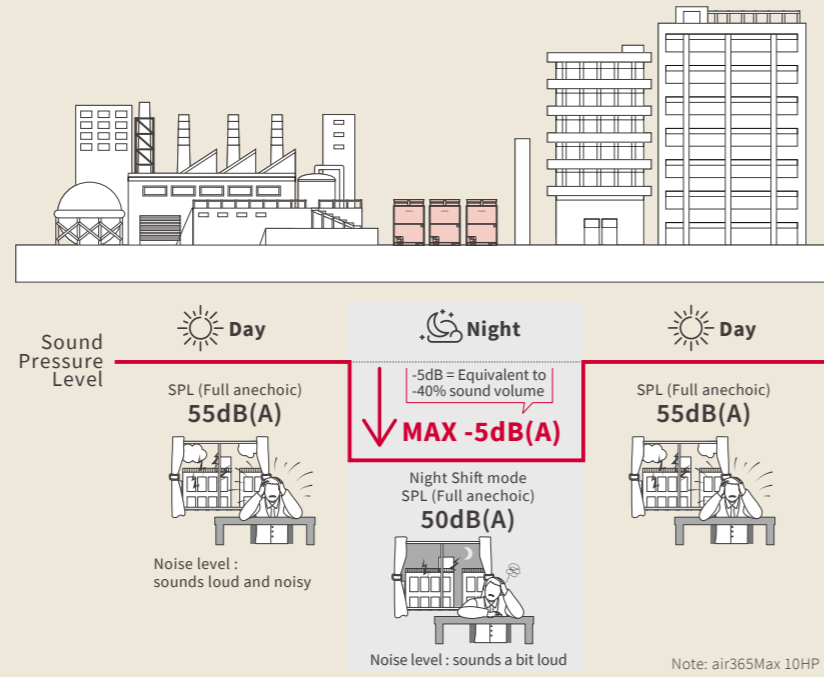

ORIGINAL DIRECT capacity control SmoothDrive™ 2.0

- Constant indoor temperature even during part-load operation

With continuous monitoring and adjustment of the capacity based on compressor speed, indoor temperatures can be maintained more accurately.

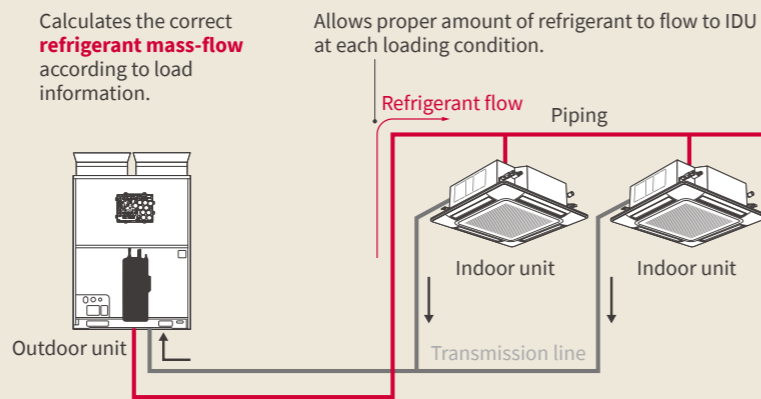

- SmoothDrive helps the scroll compressor to run continuously and smoothly even at part-load condition.
- Our original load-speculation technology helps reduce energy loss caused by scroll compressor switching on/off.
- Consequently, constant room temperature & energy savings can be achieved.

50% Load

Cooling Mode

Set temp: 27°C
Initial IDU temp: 27°C / 19°C

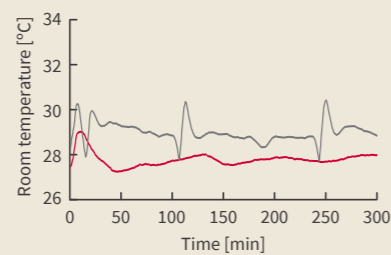

Heating Mode

Set temp: 20°C
Initial IDU temp: 20°C / 14°C

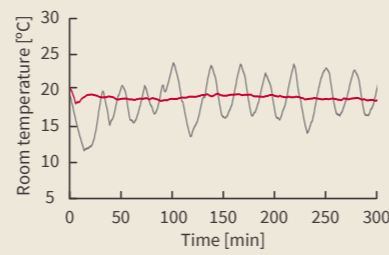

— Air Inlet temperature of IDUs (without SmoothDrive)
— Air Inlet temperature of IDUs (with SmoothDrive)



* Outdoor Unit; 10HP class. Indoor Unit: 5HP Class 4-way cassette unit * 2 pcs. In our own company's fixed-load testing facility (Dimension of the room per one indoor unit: 5.6m×2.5m×3.1m). Outdoor temp (DB / WB): 29°C / 19°C. Load per room (Sensible / Latent): 4.9kW / 0.0kW. Set temperature: 27°C. Initial Indoor unit temperature (DB / WB): 27°C / 19°C. Indoor unit fan airflow rate: Hi-mode.



IAQ matter (optional accessory)

ViroSense S filter*

Our standard VRF filter has been upgraded to ion technology

Contains a silver ion that is released in the presence of moisture, binding to cellular enzymes of microbes and inhibiting enzyme activity of the cell wall, membrane, and nucleic acids.

Anti-virus (>99% inhibition) / Anti-bacteria (>99% inhibition) / Anti-mold (100% growth stop)

Standard-equipped filter ViroSense S filter



BENEFITS

ANTI-VIRUS



over 99% Inhibition

ANTI-BACTERIA



over 99% Inhibition

ANTI-MOLD



100% growth stop

*applicable for HAPQ 4 Way cassette IDU if panel model P-AP160NAE2

AQtiv-Ion Kit*

AQtiv-Ion Kit for Ducted units

- Easily installed in a VRF ducted indoor unit
- A low-maintenance non-intrusive way of purifying air without installing separate purification units
- Generates negative ions and emits through AC airflow, binding to pollutants sending them to the floor
- Plug & play: convert your ducted IDU into an air-purifying IDU

- More than 99.9% effective on SARS-CoV-2 virus
- Up to 96.85% capturing of Influenza virus
- Up to 74.90% removal of odors (formaldehyde)
- Minimum impact on energy consumption & noise compared to external air purifier
- Electrical power consumption: max 3W

Optional accessory filter AQtiv-Ion Kit



BENEFITS

SARS-CoV-2



-99.9%
(Inhibition rate)

Escherichia coli



-96.64%
(Inhibition rate)

Influenza virus



-96.85%
(Removal rate)

Staphylococcus aureus

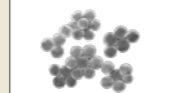

-93.88%
(Inhibition rate)

PM2.5



-94.46%
(Removal rate)

Formaldehyde

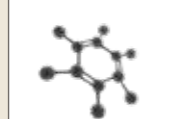

-74.90%
(Removal rate)

Ammonia



-73.20%
(Removal rate)

* Applicable for HAPQ Ducted IDU only

Smart cool/heat changeover

· Optimized comfort for all users during season changes

With Heat Pump type system, you can control how the system decides to switch between heating and cooling modes.

- Based on how many areas require cooling vs heating (majority voting)
- Based on total gap between set and ambient temperature across all rooms
- Based on prioritized rooms

Previously	Cooling / heating smart switching function		
First push priority	1 Majority mode	2 Larger gap mode	3 Priority unit mode
Adopt the mode of the first demand	Adopted operation mode with a large number of units for cooling and heating	Operation mode with a large sum of temperature differences is adopted	Adoption of priority indoor unit operation mode
<p>Cooling mode Heating mode</p> <p>↓</p> <p>Cooling mode is adopted. Ignored except first push.</p>	<p>Cooling mode Heating mode Heating mode</p> <p>↓</p> <p>Cooling mode 1 unit < Heating mode 2 units</p> <p>adopted</p>	<p>Cooling mode Heating mode Heating mode</p> <p>↓</p> <p>Cooling mode Δ4°C < Heating mode Δ1°C Heating mode Δ1°C</p> <p>adopted</p>	<p>Heating mode Cooling mode Heating mode</p> <p>↓</p> <p>priority indoor unit</p> <p>Priority indoor unit requests cooling mode</p> <p>adopted adopted adopted</p>

Example of 3 modes

1 Majority mode

Under the conditions

Request for cooling mode: 2 units
Request for heating mode: 6 units

Demand

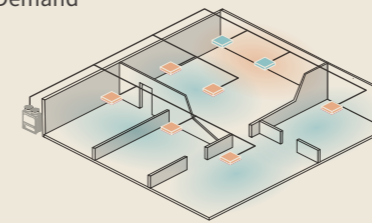

Result

Adopted Heating mode



2 Larger gap mode

Under the conditions

Cooling demand: temp. differences is total Δ8°C
Heating demand: temp. differences is total Δ5°C

Demand

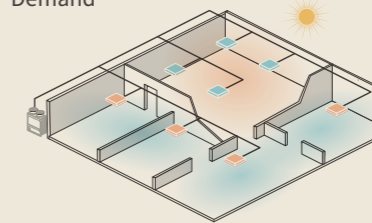

Result

Adopted Cooling mode



3 Priority unit mode

Under the conditions

Priority indoor unit requests cooling mode

Demand

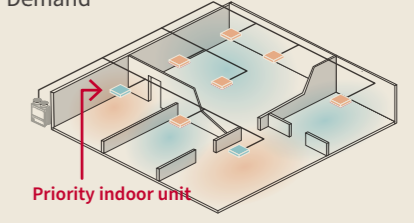

Result

Adopted Cooling mode

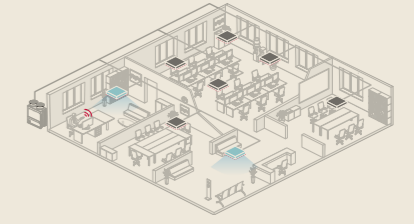

Outdoor unit lineup overview



Single module up to **28HP** class (Heat Pump Model) & **30HP** class (Cooling Model)

LINE UP (HP Class)

Heat Pump Model Range

8-12

14-18

20-28

Cooling Model Range

8-14

16-20

22-30

Specification Notes

- (Note 1) The cooling and heating performances are the values when combined with our specified indoor units.
[Cooling: 27°C DB/19°C WB indoor side, 35°C DB outdoor side] [Heating: 20°C DB indoor side, 7°C DB/6°C WB outdoor side]
Piping Length: 7.5 Meters Piping Lift: 0 Meter
- (Note 2) The electric characteristics show values of single outdoor unit.
- (Note 3) The operating sound is based on the following conditions. 1 Meter from the unit service cover surface, and 1.5 Meters from floor level.
The above data was measured in an anechoic chamber so that reflected sound should be taken into consideration in the field.
- (Note 4) The dimensions show values when a space between outdoor units is 20 mm.
- (Note 5) In case of setting low ambient temperature at cooling operation, the minimum capacity of connectable indoor unit should be 2.5HP.
- (Note 6) When 0.6HP indoor unit is combined, the total capacity of combined indoor units should be not over 150% against the outdoor unit capacity.
- (Note 7) Refrigerant piping has some installation limitation in specific condition. Please refer to technical manual for more details.
- (Note 8) When connection ratio of outdoor unit and indoor unit is over 130%, additional setting is required. Air volume of indoor unit is restricted under some of condition. Please refer to technical manual for more details.
- (Note 9) Outside temperature (-10°C) is for special application requiring optional accessory (snow protection hood). The number <-> shows Interval Operation Range. Please refer to technical manual for more details.
- (Note 10) It is recommended to follow "Recommended IDU number" to avoid the cold draft during the heating operation. Please refer to technical manual for more details.
- (Note 11) Some restrictions would be applied when the height difference between outdoor units and indoor units is more than 50m: in case of ODU above IDU or 40m: in case of IDU above ODU. Please refer to technical manual for more details.

Specifications Heat Pump

S



M



L



Capacity range	Unit	8HP class	10HP class	12HP class	14HP class	16HP class	18HP class	20HP class	22HP class	24HP class	26HP class	28HP class	
Outdoor unit model		RAS-080HNCCLI	RAS-100HNCCLI	RAS-120HNCCLI	RAS-140HNCCLI	RAS-160HNCCLI	RAS-180HNCCLI	RAS-200HNCCLI	RAS-220HNCCLI	RAS-240HNCCLI	RAS-260HNCCLI	RAS-280HNCCLI	
Combination of modules		-	-	-	-	-	-	-	-	-	-	-	
Power supply	-	3N~ 380-415V 50Hz	3N~ 380-415V 50Hz	3N~ 380-415V 50Hz	3N~ 380-415V 50Hz	3N~ 380-415V 50Hz	3N~ 380-415V 50Hz	3N~ 380-415V 50Hz	3N~ 380-415V 50Hz	3N~ 380-415V 50Hz	3N~ 380-415V 50Hz	3N~ 380-415V 50Hz	
Cooling capacity	kW	22.4	28.0	33.5	40.0	45.0	50.4	56.0	61.5	67.0	73.0	77.5	
Heating capacity	kW	25.0	31.5	37.5	45.0	50.0	56.0	63.0	69.0	77.5	81.5	86.0	
Outer dimensions (W x D x H)	mm	975×775×1805	975×775×1805	975×775×1805	1235×775×1805	1235×775×1805	1235×775×1805	1625×775×1805	1625×775×1805	1625×775×1805	1625×775×1805	1625×775×1805	
Weight	Net weight	kg	207	212	226	281	282	364	364	364	390	390	
	Gross weight	kg	226	231	245	302	303	388	388	388	414	414	
Noise	Cooling rating	SPL (Full-anechoic) dB(A)	52	55	57	59	61	63	63	61	62	62	
	Night shift mode (noise reduction setting)	SPL (Full-anechoic) dB(A)	49	50	52	57	58	56	57	57	60	60	
Compressor	Compressor type	-	Hermetic (Scroll)	Hermetic (Scroll)	Hermetic (Scroll)	Hermetic (Scroll)	Hermetic (Scroll)	Hermetic (Scroll)	Hermetic (Scroll)	Hermetic (Scroll)	Hermetic (Scroll)	Hermetic (Scroll)	
	Rated air volume	m³/min	175	175	198	239	256	263	329	329	348	375	
Outdoor unit Fan	Number of Fan Motors	-	1	1	1	2	2	2	2	2	2	2	
	Motor output	kW	0.26	0.26	0.43	0.3×2	0.35×2	0.38×2	0.4×2	0.4×2	0.47×2	0.58×2	
Main pipe size	Heat pump	Gas piping	mm	19.05	22.2	25.4	25.4	28.58	28.58	28.58	28.58	31.75	31.75
		Liquid piping	mm	9.52	9.52	12.7	12.7	12.7	15.88	15.88	15.88	19.05	19.05
	Tubing connection method	-	Brazing connection	Brazing connection	Brazing connection	Brazing connection	Brazing connection	Brazing connection	Brazing connection	Brazing connection	Brazing connection	Brazing connection	Brazing connection
Operating temperature range	Cooling	°C DB	-5°C ~52°C	-5°C ~52°C	-5°C ~52°C	-5°C ~52°C	-5°C ~52°C	-5°C ~52°C	-5°C ~52°C	-5°C ~52°C	-5°C ~52°C	-5°C ~52°C	
	Heating	°C WB	-15°C~16°C	-15°C~16°C	-15°C~16°C	-15°C~16°C	-15°C~16°C	-15°C~16°C	-15°C~16°C	-15°C~16°C	-15°C~16°C	-15°C~16°C	
Maximum External static pressure	Pa	80	80	80	80	80	80	80	80	80	80	80	
Maximum Total piping length	m	1,000	1,000	1,000	1,000	1,000	1,000	1,000	1,000	1,000	1,000	1,000	
Refrigerant	Type	-	R410A	R410A	R410A	R410A	R410A	R410A	R410A	R410A	R410A	R410A	
	Initial charge amount	kg	5.6	5.6	8.3	8.9	9.5	10.2	11.2	11.2	11.5	11.5	
	Maximum additional charge amount	kg	28.0	28.0	36.0	40.0	40.0	40.0	46.0	46.0	46.0	56.0	
	Refrigerant control mode	-	Microcomputer-controlled electronic expansion valve					Microcomputer-controlled electronic expansion valve					
Refrigerant oil	Type	-	FVC68D	FVC68D	FVC68D	FVC68D	FVC68D	FVC68D	FVC68D	FVC68D	FVC68D	FVC68D	
	Charge amount	L	6.0	6.0	6.0	6.9	6.9	6.9	8.4	8.4	8.4	8.4	
With Indoor Unit	Connected capacity ratio	%	50~200%	50~200%	50~200%	50~200%	50~200%	50~200%	50~200%	50~200%	50~200%	50~200%	
	Maximum Number of connectable units (recommended number of units)	-	20 (8)	25 (10)	30 (10)	36 (16)	40 (16)	45 (16)	50 (18)	55 (20)	60 (26)	64 (32)	
	Connectable minimum capacity	HP	0.6	0.6	0.6	0.6	0.6	0.6	0.6	0.6	0.6	0.6	

Specifications Heat Pump



Capacity range		Unit	30HP class	32HP class	34HP class	36HP class	38HP class	40HP class	42HP class	44HP class	46HP class	48HP class	50HP class
Outdoor unit model			RAS-300HNCCLI	RAS-320HNCCLI	RAS-340HNCCLI	RAS-360HNCCLI	RAS-380HNCCLI	RAS-400HNCCLI	RAS-420HNCCLI	RAS-440HNCCLI	RAS-460HNCCLI	RAS-480HNCCLI	RAS-500HNCCLI
Combination of modules			RAS-180HNCCLI RAS-120HNCCLI	RAS-180HNCCLI RAS-140HNCCLI	RAS-180HNCCLI RAS-160HNCCLI	RAS-180HNCCLI RAS-180HNCCLI	RAS-220HNCCLI RAS-160HNCCLI	RAS-220HNCCLI RAS-180HNCCLI	RAS-240HNCCLI RAS-180HNCCLI	RAS-220HNCCLI RAS-220HNCCLI	RAS-240HNCCLI RAS-220HNCCLI	RAS-240HNCCLI RAS-240HNCCLI	RAS-260HNCCLI RAS-240HNCCLI
Power supply		-	3N~ 380-415V 50Hz	3N~ 380-415V 50Hz	3N~ 380-415V 50Hz	3N~ 380-415V 50Hz	3N~ 380-415V 50Hz	3N~ 380-415V 50Hz	3N~ 380-415V 50Hz	3N~ 380-415V 50Hz	3N~ 380-415V 50Hz	3N~ 380-415V 50Hz	3N~ 380-415V 50Hz
Cooling capacity		kW	83.9	90.4	95.4	100.8	106.5	111.9	117.4	123.0	128.5	134.0	140.0
Heating capacity		kW	93.5	101.0	106.0	112.0	119.0	125.0	133.5	138.0	146.5	155.0	159.0
Outer dimensions (W x D x H)		mm	2230×775×1805	2490×775×1805	2490×775×1805	2490×775×1805	2880×775×1805	2880×775×1805	2880×775×1805	3270×775×1805	3270×775×1805	3270×775×1805	3270×775×1805
Weight	Net weight	kg	282+226	282+281	282+281	282+282	364+281	364+282	364+282	364+364	364+364	364+364	390+364
	Gross weight	kg	303+245	303+302	303+303	303+303	388+303	388+303	388+303	388+388	388+388	388+388	414+388
Noise	Cooling rating	SPL (Full-anechoic) dB(A)	62	63	64	64	65	65	64	66	65	64	65
	Night shift mode (noise reduction setting)	SPL (Full-anechoic) dB(A)	58	60	61	60	61	60	60	60	60	60	62
Compressor	Compressor type	-	Hermetic (Scroll)	Hermetic (Scroll)	Hermetic (Scroll)	Hermetic (Scroll)	Hermetic (Scroll)	Hermetic (Scroll)	Hermetic (Scroll)	Hermetic (Scroll)	Hermetic (Scroll)	Hermetic (Scroll)	Hermetic (Scroll)
	Rated air volume	m ³ /min	263+198	263+239	263+256	263×2	329+256	329+263	348+263	329×2	348+329	348×2	375+348
Outdoor unit Fan	Number of Fan Motors	-	2+1	2+2	2+2	2+2	2+2	2+2	2+2	2+2	2+2	2+2	2+2
	Motor output	kW	0.38×2+0.43	0.38×2+0.3×2	0.38×2+0.35×2	(0.38×2)×2	0.4×2+0.35×2	0.4×2+0.38×2	0.47×2+0.38×2	(0.4×2)×2	0.47×2+0.4×2	(0.47×2)×2	0.58×2+0.47×2
Main pipe size	Heat pump	Gas piping	mm	31.75	31.75	31.75	38.1	38.1	38.1	38.1	38.1	38.1	38.1
		Liquid piping	mm	19.05	19.05	19.05	19.05	19.05	19.05	19.05	19.05	19.05	19.05
	Tube connection method	-	Brazing connection	Brazing connection	Brazing connection	Brazing connection	Brazing connection	Brazing connection	Brazing connection	Brazing connection	Brazing connection	Brazing connection	Brazing connection
Operating temperature range	Cooling	°C DB	-5°C ~52°C	-5°C ~52°C	-5°C ~52°C	-5°C ~52°C	-5°C ~52°C	-5°C ~52°C	-5°C ~52°C	-5°C ~52°C	-5°C ~52°C	-5°C ~52°C	-5°C ~52°C
	Heating	°C WB	-15°C ~16°C	-15°C ~16°C	-15°C ~16°C	-15°C ~16°C	-15°C ~16°C	-15°C ~16°C	-15°C ~16°C	-15°C ~16°C	-15°C ~16°C	-15°C ~16°C	-15°C ~16°C
Maximum External static pressure		Pa	80	80	80	80	80	80	80	80	80	80	80
Maximum Total piping length		m	1,000	1,000	1,000	1,000	1,000	1,000	1,000	1,000	1,000	1,000	1,000
Refrigerant	Type	-	R410A	R410A	R410A	R410A	R410A	R410A	R410A	R410A	R410A	R410A	R410A
	Initial charge amount	kg	18.5	19.1	19.7	20.4	20.7	21.4	21.7	22.4	22.7	23.0	23.0
	Maximum additional charge amount	kg	56.5	56.5	56.5	56.5	56.5	56.5	56.5	63.0	63.0	63.0	63.0
	Refrigerant control mode	-	Microcomputer-controlled electronic expansion valve				Microcomputer-controlled electronic expansion valve						
Refrigerant oil	Type	-	FVC68D	FVC68D	FVC68D	FVC68D	FVC68D	FVC68D	FVC68D	FVC68D	FVC68D	FVC68D	FVC68D
	Charge amount	L	12.9	13.8	13.8	13.8	15.3	15.3	15.3	16.8	16.8	16.8	16.8
Connected capacity ratio		%	50~200%	50~200%	50~200%	50~200%	50~200%	50~200%	50~200%	50~200%	50~200%	50~200%	50~200%
With Indoor Unit	Maximum Number of connectable units (recommended number of units)	-	64 (32)	64 (32)	64 (32)	64 (32)	64 (38)	64 (38)	64 (38)	64 (38)	64 (38)	64 (38)	64 (38)
	Connectable minimum capacity	HP	0.6	0.6	0.6	0.6	0.6	0.6	0.6	0.6	0.6	0.6	0.6

Specifications Heat Pump

LL



LMM



LLM



LLL



Capacity range	Unit	52HP class	54HP class	56HP class	58HP class	60HP class	62HP class	64HP class	66HP class	68HP class	70HP class	72HP class
Outdoor unit model		RAS-520HNCCLI	RAS-540HNCCLI	RAS-560HNCCLI	RAS-580HNCCLI	RAS-600HNCCLI	RAS-620HNCCLI	RAS-640HNCCLI	RAS-660HNCCLI	RAS-680HNCCLI	RAS-700HNCCLI	RAS-720HNCCLI
Combination of modules		RAS-260HNCCLI RAS-260HNCCLI	RAS-280HNCCLI RAS-260HNCCLI	RAS-280HNCCLI RAS-280HNCCLI	RAS-220HNCCLI RAS-180HNCCLI RAS-180HNCCLI	RAS-240HNCCLI RAS-180HNCCLI RAS-180HNCCLI	RAS-220HNCCLI RAS-220HNCCLI RAS-180HNCCLI	RAS-240HNCCLI RAS-220HNCCLI RAS-180HNCCLI	RAS-240HNCCLI RAS-240HNCCLI RAS-180HNCCLI	RAS-240HNCCLI RAS-220HNCCLI RAS-220HNCCLI	RAS-240HNCCLI RAS-240HNCCLI RAS-220HNCCLI	RAS-240HNCCLI RAS-240HNCCLI RAS-240HNCCLI
Power supply	-	3N~ 380-415V 50Hz	3N~ 380-415V 50Hz	3N~ 380-415V 50Hz	3N~ 380-415V 50Hz	3N~ 380-415V 50Hz	3N~ 380-415V 50Hz	3N~ 380-415V 50Hz	3N~ 380-415V 50Hz	3N~ 380-415V 50Hz	3N~ 380-415V 50Hz	3N~ 380-415V 50Hz
Cooling capacity	kW	146.0	150.5	155.0	162.3	167.8	173.4	178.9	184.4	190.0	195.5	201.0
Heating capacity	kW	163.0	167.5	172.0	181.0	189.5	194.0	202.5	211.0	215.5	224.0	232.5
Outer dimensions (W x D x H)	mm	3270×775×1805	3270×775×1805	3270×775×1805	4135×775×1805	4135×775×1805	4525×775×1805	4525×775×1805	4525×775×1805	4915×775×1805	4915×775×1805	4915×775×1805
Weight	Net weight	kg	390+390	390+390	390+390	364+282+282	364+282+282	364+364+282	364+364+282	364+364+282	364+364+364	364+364+364
	Gross weight	kg	414+414	414+414	414+414	388+303+303	388+303+303	388+388+303	388+388+303	388+388+303	388+388+388	388+388+388
Noise	Cooling rating	SPL (Full-anechoic) dB(A)	65	65	65	67	66	67	67	66	67	66
	Night shift mode (noise reduction setting)	SPL (Full-anechoic) dB(A)	63	63	63	62	62	62	62	62	62	62
Compressor	Compressor type	-	Hermetic (Scroll)	Hermetic (Scroll)	Hermetic (Scroll)	Hermetic (Scroll)	Hermetic (Scroll)	Hermetic (Scroll)	Hermetic (Scroll)	Hermetic (Scroll)	Hermetic (Scroll)	Hermetic (Scroll)
Outdoor unit Fan	Rated air volume	m ³ /min	375×2	375+375	375×2	329+263×2	348+263×2	329×2+263	348+329+263	348×2+263	348+329×2	348×2+329
	Number of Fan Motors	-	2+2	2+2	2+2	2+2+2	2+2+2	2+2+2	2+2+2	2+2+2	2+2+2	2+2+2
Main pipe size	Heat pump	Gas piping	mm	38.1	38.1	44.45	44.45	44.45	44.45	44.45	44.45	44.45
		Liquid piping	mm	19.05	19.05	19.05	19.05	19.05	19.05	19.05	22.2	22.2
	Tube connection method	-	Brazing connection	Brazing connection	Brazing connection	Brazing connection	Brazing connection	Brazing connection	Brazing connection	Brazing connection	Brazing connection	Brazing connection
Operating temperature range	Cooling	°C DB	-5°C ~52°C	-5°C ~52°C	-5°C ~52°C	-5°C ~52°C	-5°C ~52°C	-5°C ~52°C	-5°C ~52°C	-5°C ~52°C	-5°C ~52°C	-5°C ~52°C
	Heating	°C WB	-15°C~16°C	-15°C~16°C	-15°C~16°C	-15°C~16°C	-15°C~16°C	-15°C~16°C	-15°C~16°C	-15°C~16°C	-15°C~16°C	-15°C~16°C
Maximum External static pressure	Pa	80	80	80	80	80	80	80	80	80	80	
Maximum Total piping length	m	1,000	1,000	1,000	1,000	1,000	1,000	1,000	1,000	1,000	1,000	
Refrigerant	Type	-	R410A	R410A	R410A	R410A	R410A	R410A	R410A	R410A	R410A	R410A
	Initial charge amount	kg	23.0	23.0	23.0	31.6	31.9	32.6	32.9	33.2	33.9	34.5
	Maximum additional charge amount	kg	63.0	63.0	63.0	63.0	63.0	63.0	63.0	63.0	73.0	73.0
	Refrigerant control mode	-	Microcomputer-controlled electronic expansion valve					Microcomputer-controlled electronic expansion valve				
Refrigerant oil	Type	-	FVC68D	FVC68D	FVC68D	FVC68D	FVC68D	FVC68D	FVC68D	FVC68D	FVC68D	FVC68D
	Charge amount	L	16.8	16.8	16.8	22.2	22.2	23.7	23.7	23.7	25.2	25.2
With Indoor Unit	Connected capacity ratio	%	50~200%	50~200%	50~180%	50~150%	50~150%	50~150%	50~150%	50~150%	50~150%	50~150%
	Maximum Number of connectable units (recommended number of units)	-	64 (38)	64 (38)	64 (38)	64 (38)	64 (38)	64 (38)	64 (38)	64 (38)	64 (38)	64 (38)
	Connectable minimum capacity	HP	0.6	0.6	0.6	0.6	0.6	0.6	0.6	0.6	0.6	0.6

Specifications Heat Pump

LLL



LLLM



LLLL



Capacity range	Unit	74HP class	76HP class	78HP class	80HP class	82HP class	84HP class	86HP class	88HP class	90HP class	92HP class	94HP class
Outdoor unit model		RAS-740HNCCLI	RAS-760HNCCLI	RAS-780HNCCLI	RAS-800HNCCLI	RAS-820HNCCLI	RAS-840HNCCLI	RAS-860HNCCLI	RAS-880HNCCLI	RAS-900HNCCLI	RAS-920HNCCLI	RAS-940HNCCLI
Combination of modules		RAS-260HNCCLI RAS-240HNCCLI RAS-240HNCCLI	RAS-260HNCCLI RAS-260HNCCLI RAS-240HNCCLI	RAS-260HNCCLI RAS-260HNCCLI RAS-260HNCCLI	RAS-280HNCCLI RAS-260HNCCLI RAS-260HNCCLI	RAS-280HNCCLI RAS-280HNCCLI RAS-260HNCCLI	RAS-280HNCCLI RAS-280HNCCLI RAS-280HNCCLI	RAS-240HNCCLI RAS-220HNCCLI RAS-220HNCCLI RAS-180HNCCLI	RAS-240HNCCLI RAS-240HNCCLI RAS-220HNCCLI RAS-180HNCCLI	RAS-240HNCCLI RAS-240HNCCLI RAS-240HNCCLI RAS-180HNCCLI	RAS-240HNCCLI RAS-240HNCCLI RAS-220HNCCLI RAS-220HNCCLI	RAS-240HNCCLI RAS-240HNCCLI RAS-240HNCCLI RAS-220HNCCLI
Power supply	-	3N~ 380-415V 50Hz	3N~ 380-415V 50Hz	3N~ 380-415V 50Hz	3N~ 380-415V 50Hz	3N~ 380-415V 50Hz	3N~ 380-415V 50Hz	3N~ 380-415V 50Hz	3N~ 380-415V 50Hz	3N~ 380-415V 50Hz	3N~ 380-415V 50Hz	3N~ 380-415V 50Hz
Cooling capacity	kW	207.0	213.0	219.0	223.5	228.0	232.5	240.4	245.9	251.4	257.0	262.5
Heating capacity	kW	236.5	240.5	244.5	249.0	253.5	258.0	271.5	280.0	288.5	293.0	301.5
Outer dimensions (W x D x H)	mm	4915×775×1805	4915×775×1805	4915×775×1805	4915×775×1805	4915×775×1805	4915×775×1805	6170×775×1805	6170×775×1805	6170×775×1805	6560×775×1805	6560×775×1805
Weight	Net weight	kg	390+364+364	390+390+364	390+390+390	390+390+390	390+390+390	364+364+364+282	364+364+364+282	364+364+364+282	364+364+364+364	364+364+364+364
	Gross weight	kg	414+388+388	414+414+388	414+414+414	414+414+414	414+414+414	414+414+414	388+388+388+303	388+388+388+303	388+388+388+303	388+388+388+388
Noise	Cooling rating	SPL (Full-anechoic) dB(A)	66	66	67	67	67	67	67	67	68	68
	Night shift mode (noise reduction setting)	SPL (Full-anechoic) dB(A)	63	64	65	65	65	65	63	63	63	63
Compressor	Compressor type	-	Hermetic (Scroll)	Hermetic (Scroll)	Hermetic (Scroll)	Hermetic (Scroll)	Hermetic (Scroll)	Hermetic (Scroll)	Hermetic (Scroll)	Hermetic (Scroll)	Hermetic (Scroll)	Hermetic (Scroll)
	Rated air volume	m ³ /min	375+348×2	375×2+348	375×3	375+375×2	375×2+375	375×3	348+329×2+263	348×2+329+263	348×3+263	348×2+329×2
Outdoor unit Fan	Number of Fan Motors	-	2+2+2	2+2+2	2+2+2	2+2+2	2+2+2	2+2+2+2	2+2+2+2	2+2+2+2	2+2+2+2	2+2+2+2
	Motor output	kW	0.58×2+(0.47×2)×2	(0.58×2)×2+0.47×2	(0.58×2)×3	0.58×2+(0.58×2)×2	(0.58×2)×2+0.58×2	(0.58×2)×3	0.47×2+(0.4×2)×2+0.38×2	(0.47×2)×2+0.4×2+0.38×2	(0.47×2)×3+0.38×2	(0.47×2)×2+(0.4×2)×2
Main pipe size	Heat pump	Gas piping	mm	50.8	50.8	50.8	50.8	50.8	50.8	50.8	50.8	50.8
		Liquid piping	mm	22.2	22.2	22.2	22.2	22.2	22.2	22.2	25.4	25.4
	Tubing connection method	-	Brazing connection	Brazing connection	Brazing connection	Brazing connection	Brazing connection	Brazing connection	Brazing connection	Brazing connection	Brazing connection	Brazing connection
Operating temperature range	Cooling	°C DB	-5°C ~52°C	-5°C ~52°C	-5°C ~52°C	-5°C ~52°C	-5°C ~52°C	-5°C ~52°C	-5°C ~52°C	-5°C ~52°C	-5°C ~52°C	-5°C ~52°C
	Heating	°C WB	-15°C ~16°C	-15°C ~16°C	-15°C ~16°C	-15°C ~16°C	-15°C ~16°C	-15°C ~16°C	-15°C ~16°C	-15°C ~16°C	-15°C ~16°C	-15°C ~16°C
Maximum External static pressure	Pa	80	80	80	80	80	80	80	80	80	80	80
Maximum Total piping length	m	1,000	1,000	1,000	1,000	1,000	1,000	1,000	1,000	1,000	1,000	1,000
Refrigerant	Type	-	R410A	R410A	R410A	R410A	R410A	R410A	R410A	R410A	R410A	R410A
	Initial charge amount	kg	34.5	34.5	34.5	34.5	34.5	34.5	44.1	44.4	44.7	45.4
	Maximum additional charge amount	kg	73.0	73.0	73.0	73.0	73.0	73.0	73.0	73.0	93.0	93.0
	Refrigerant control mode	-	Microcomputer-controlled electronic expansion valve					Microcomputer-controlled electronic expansion valve				
Refrigerant oil	Type	-	FVC68D	FVC68D	FVC68D	FVC68D	FVC68D	FVC68D	FVC68D	FVC68D	FVC68D	FVC68D
	Charge amount	L	25.2	25.2	25.2	25.2	25.2	25.2	32.1	32.1	32.1	33.6
With Indoor Unit	Connected capacity ratio	%	50~150%	50~150%	50~150%	50~150%	50~150%	50~150%	50~150%	50~150%	50~150%	50~150%
	Maximum Number of connectable units (recommended number of units)	-	64 (38)	64 (38)	64 (38)	64 (38)	64 (38)	64 (38)	64 (38)	64 (38)	64 (38)	64 (38)
	Connectable minimum capacity	HP	0.6	0.6	0.6	0.6	0.6	0.6	0.6	0.6	0.6	0.6

Specifications Heat Pump



Capacity range		Unit	96HP class	98HP class	100HP class	102HP class	104HP class	106HP class	108HP class	110HP class	112HP class
Outdoor unit model			RAS-960HNCCLI	RAS-980HNCCLI	RAS-H00HNCCLI	RAS-H02HNCCLI	RAS-H04HNCCLI	RAS-H06HNCCLI	RAS-H08HNCCLI	RAS-H10HNCCLI	RAS-H12HNCCLI
Combination of modules			RAS-240HNCCLI RAS-240HNCCLI RAS-240HNCCLI RAS-240HNCCLI	RAS-260HNCCLI RAS-240HNCCLI RAS-240HNCCLI RAS-240HNCCLI	RAS-260HNCCLI RAS-260HNCCLI RAS-240HNCCLI RAS-240HNCCLI	RAS-260HNCCLI RAS-260HNCCLI RAS-260HNCCLI RAS-240HNCCLI	RAS-260HNCCLI RAS-260HNCCLI RAS-260HNCCLI RAS-260HNCCLI	RAS-280HNCCLI RAS-260HNCCLI RAS-260HNCCLI RAS-260HNCCLI	RAS-280HNCCLI RAS-280HNCCLI RAS-260HNCCLI RAS-260HNCCLI	RAS-280HNCCLI RAS-280HNCCLI RAS-280HNCCLI RAS-260HNCCLI	RAS-280HNCCLI RAS-280HNCCLI RAS-280HNCCLI RAS-280HNCCLI
Power supply		-	3N~ 380-415V 50Hz	3N~ 380-415V 50Hz	3N~ 380-415V 50Hz	3N~ 380-415V 50Hz	3N~ 380-415V 50Hz	3N~ 380-415V 50Hz	3N~ 380-415V 50Hz	3N~ 380-415V 50Hz	3N~ 380-415V 50Hz
Cooling capacity		kW	268.0	274.0	280.0	286.0	292.0	296.5	301.0	305.5	310.0
Heating capacity		kW	310.0	314.0	318.0	322.0	326.0	330.5	335.0	339.5	344.0
Outer dimensions (W x D x H)		mm	6560×775×1805	6560×775×1805	6560×775×1805	6560×775×1805	6560×775×1805	6560×775×1805	6560×775×1805	6560×775×1805	6560×775×1805
Weight	Net weight	kg	364+364+364+364	390+364+364+364	390+390+364+364	390+390+390+364	390+390+390+390	390+390+390+390	390+390+390+390	390+390+390+390	390+390+390+390
	Gross weight	kg	388+388+388+388	414+388+388+388	414+414+388+388	414+414+414+388	414+414+414+414	414+414+414+414	414+414+414+414	414+414+414+414	414+414+414+414
Noise	Cooling rating	SPL (Full-anechoic) dB(A)	67	67	68	68	68	68	68	68	68
	Night shift mode (noise reduction setting)	SPL (Full-anechoic) dB(A)	63	64	65	65	66	66	66	66	66
Compressor	Compressor type	-	Hermetic (Scroll)	Hermetic (Scroll)	Hermetic (Scroll)	Hermetic (Scroll)	Hermetic (Scroll)	Hermetic (Scroll)	Hermetic (Scroll)	Hermetic (Scroll)	Hermetic (Scroll)
	Rated air volume	m ³ /min	348×4	375+348×3	375×2+348×2	375×3+348	375×4	375+375×3	375×2+375×2	375×3+375	375×4
Outdoor unit Fan	Number of Fan Motors	-	2+2+2+2	2+2+2+2	2+2+2+2	2+2+2+2	2+2+2+2	2+2+2+2	2+2+2+2	2+2+2+2	2+2+2+2
	Motor output	kW	(0.47×2)×4	0.58×2+(0.47×2)×3	(0.58×2)×2+(0.47×2)×2	(0.58×2)×3+0.47×2	(0.58×2)×4	0.58×2+(0.58×2)×3	(0.58×2)×2+(0.58×2)×2	(0.58×2)×3+0.58×2	(0.58×2)×4
Main pipe size	Heat pump	Gas piping	mm	50.8	54.0	54.0	54.0	54.0	54.0	54.0	54.0
		Liquid piping	mm	25.4	25.4	25.4	25.4	25.4	25.4	25.4	25.4
	Tubing connection method	-	Brazing connection	Brazing connection	Brazing connection	Brazing connection	Brazing connection	Brazing connection	Brazing connection	Brazing connection	Brazing connection
Operating temperature range	Cooling	°C DB	-5°C ~52°C	-5°C ~52°C	-5°C ~52°C	-5°C ~52°C	-5°C ~52°C	-5°C ~52°C	-5°C ~52°C	-5°C ~52°C	-5°C ~52°C
	Heating	°C WB	-15°C ~16°C	-15°C ~16°C	-15°C ~16°C	-15°C ~16°C	-15°C ~16°C	-15°C ~16°C	-15°C ~16°C	-15°C ~16°C	-15°C ~16°C
Maximum External static pressure		Pa	80	80	80	80	80	80	80	80	80
Maximum Total piping length		m	1,000	1,000	1,000	1,000	1,000	1,000	1,000	1,000	1,000
Refrigerant	Type	-	R410A	R410A	R410A	R410A	R410A	R410A	R410A	R410A	R410A
	Initial charge amount	kg	46.0	46.0	46.0	46.0	46.0	46.0	46.0	46.0	46.0
	Maximum additional charge amount	kg	93.0	93.0	93.0	93.0	93.0	93.0	93.0	93.0	93.0
	Refrigerant control mode	-	Microcomputer-controlled electronic expansion valve				Microcomputer-controlled electronic expansion valve				
Refrigerant oil	Type	-	FVC68D	FVC68D	FVC68D	FVC68D	FVC68D	FVC68D	FVC68D	FVC68D	FVC68D
	Charge amount	L	33.6	33.6	33.6	33.6	33.6	33.6	33.6	33.6	33.6
Connected capacity ratio		%	50~150%	50~150%	50~150%	50~150%	50~150%	50~150%	50~150%	50~150%	50~150%
With Indoor Unit	Maximum Number of connectable units (recommended number of units)	-	64 (38)	64 (38)	64 (38)	64 (38)	64 (38)	64 (38)	64 (38)	64 (38)	64 (38)
	Connectable minimum capacity	HP	0.6	0.6	0.6	0.6	0.6	0.6	0.6	0.6	0.6

Specifications Cooling

S



S



M



M



L



Capacity range	Unit	8HP	10HP	12HP	14HP	16HP	18HP	20HP	22HP	24HP	26HP	28HP	
Outdoor unit model		RAS-080CNCCLI	RAS-100CNCCLI	RAS-120CNCCLI	RAS-140CNCCLI	RAS-160CNCCLI	RAS-180CNCCLI	RAS-200CNCCLI	RAS-220CNCCLI	RAS-240CNCCLI	RAS-260CNCCLI	RAS-280CNCCLI	
Power supply	-	3N~ 380-415V 50Hz	3N~ 380-415V 50Hz	3N~ 380-415V 50Hz	3N~ 380-415V 50Hz	3N~ 380-415V 50Hz	3N~ 380-415V 50Hz	3N~ 380-415V 50Hz	3N~ 380-415V 50Hz	3N~ 380-415V 50Hz	3N~ 380-415V 50Hz	3N~ 380-415V 50Hz	
Cooling capacity	kW	22.4	28	33.5	40	45	50.4	56	61.5	67	73	77.5	
Outer dimensions (W x D x H)	mm	960×775×1,805	960×775×1,805	960×775×1,805	960×775×1,805	1,220×775×1,805	1,220×775×1,805	1,220×775×1,805	1,610×775×1,805	1,610×775×1,805	1,610×775×1,805	1,610×775×1,805	
Weight	Net weight	kg	202	207	223	227	271	277	277	360	360	379	379
	Gross weight	kg	218	223	239	243	291	297	297	383	383	402	402
Noise	Cooling rating	SPL (Full-anechoic) dB(A)	52	55	57	59	61	61	61	61	61	62	62
	Night shift mode (noise reduction setting)	SPL (Full-anechoic) dB(A)	49	50	52	54	56	56	56	57	57	60	60
Compressor	Compressor type	-	Hermetic(Scroll)	Hermetic(Scroll)	Hermetic(Scroll)	Hermetic(Scroll)	Hermetic(Scroll)	Hermetic(Scroll)	Hermetic(Scroll)	Hermetic(Scroll)	Hermetic(Scroll)	Hermetic(Scroll)	
	Rated air volume	m ³ /min	175	175	198	207	256	263	263	329	348	375	375
Outdoor unit Fan	Number of Fan Motors	-	1	1	1	2	2	2	2	2	2	2	
	Motor output	kW	0.26	0.26	0.43	0.51	0.35×2	0.38×2	0.38×2	0.4×2	0.47×2	0.58×2	0.58×2
Main pipe size	Gas piping	mm	19.05	22.2	25.4	25.4	28.58	28.58	28.58	28.58	28.58	31.75	31.75
	Liquid piping	mm	9.52	9.52	12.7	12.7	12.7	15.88	15.88	15.88	15.88	19.05	19.05
	Tubing connection method	-	Brazing connection	Brazing connection	Brazing connection	Brazing connection	Brazing connection	Brazing connection	Brazing connection	Brazing connection	Brazing connection	Brazing connection	Brazing connection
Operating temperature range	°C DB	-5°C~52°C	-5°C~52°C	-5°C~52°C	-5°C~52°C	-5°C~52°C	-5°C~52°C	-5°C~52°C	-5°C~52°C	-5°C~52°C	-5°C~52°C	-5°C~52°C	
Maximum External static pressure	Pa	80	80	80	80	80	80	80	80	80	80	80	
Maximum Total piping length	m	1,000	1,000	1,000	1,000	1,000	1,000	1,000	1,000	1,000	1,000	1,000	
Refrigerant	Type	-	R410A	R410A	R410A	R410A	R410A	R410A	R410A	R410A	R410A	R410A	
	Initial charge amount	kg	5.6	5.6	8.3	8.3	9.5	10.2	10.2	11.2	11.6	11.6	
	Maximum additional charge amount	kg	28	28	36	36	40	40	40	46	46	56	
	Refrigerant control mode	-	Microcomputer-controlled electronic expansion valve				Microcomputer-controlled electronic expansion valve						
Refrigerant Oil	Type	-	FVC68D	FVC68D	FVC68D	FVC68D	FVC68D	FVC68D	FVC68D	FVC68D	FVC68D	FVC68D	
	Charge amount	L	6	6	6	6	6.9	6.9	6.9	8.4	8.4	8.4	
With Indoor unit	Connected capacity ratio	%	50~200%	50~200%	50~200%	50~200%	50~200%	50~200%	50~200%	50~200%	50~200%	50~200%	
	Maximum Number of connectable units (recommended number of units)	-	20 (8)	25 (10)	30 (10)	36 (16)	40 (16)	45 (16)	50 (18)	55 (20)	60 (26)	64 (26)	64 (32)
	Connectable minimum capacity	HP Class	0.6	0.6	0.6	0.6	0.6	0.6	0.6s	0.6	0.6	0.6	0.6

Specifications Cooling



Capacity range		Unit	30HP	32HP	34HP	36HP	38HP	40HP	42HP	44HP	46HP	48HP	50HP
Outdoor unit model			RAS-300CNCCLI	RAS-320CNCCLI	RAS-340CNCCLI	RAS-360CNCCLI	RAS-380CNCCLI	RAS-400CNCCLI	RAS-420CNCCLI	RAS-440CNCCLI	RAS-460CNCCLI	RAS-480CNCCLI	RAS-500CNCCLI
Combination of modules		-		RAS-180CNCCLI RAS-140CNCCLI	RAS-180CNCCLI RAS-160CNCCLI	RAS-180CNCCLI RAS-180CNCCLI	RAS-220CNCCLI RAS-160CNCCLI	RAS-220CNCCLI RAS-180CNCCLI	RAS-240CNCCLI RAS-180CNCCLI	RAS-220CNCCLI RAS-220CNCCLI	RAS-240CNCCLI RAS-220CNCCLI	RAS-240CNCCLI RAS-240CNCCLI	RAS-260CNCCLI RAS-240CNCCLI
Power supply		-	3N~ 380-415V 50Hz	3N~ 380-415V 50Hz	3N~ 380-415V 50Hz	3N~ 380-415V 50Hz	3N~ 380-415V 50Hz	3N~ 380-415V 50Hz	3N~ 380-415V 50Hz	3N~ 380-415V 50Hz	3N~ 380-415V 50Hz	3N~ 380-415V 50Hz	3N~ 380-415V 50Hz
Cooling capacity		-	3N~ 380-415V 50Hz	3N~ 380-415V 50Hz	3N~ 380-415V 50Hz	3N~ 380-415V 50Hz	106.5	111.9	117.4	123	128.5	134	140
Outer dimensions (W x D x H)		mm	1,610×775×1,805	2,200×775×1,805	2,460×775×1,805	2,460×775×1,805	2,850×775×1,805	2,850×775×1,805	2,850×775×1,805	3,240×775×1,805	3,240×775×1,805	3,240×775×1,805	3,240×775×1,805
Weight	Net weight	kg	379	227+277	271+277	277+277	271+360	277+360	277+360	360+360	360+360	360+360	360+379
	Gross weight	kg	402	243+297	291+297	297+297	291+383	297+383	297+383	383+383	383+383	383+383	383+402
Noise	Cooling rating	SPL (Full-anechoic) dB(A)	65	63	64	64	64	64	64	64	64	64	65
	Night shift mode (noise reduction setting)	SPL (Full-anechoic) dB(A)	60	58	59	59	60	60	60	60	60	60	62
Compressor	Compressor type	-	Hermetic(Scroll)	Hermetic(Scroll)	Hermetic(Scroll)	Hermetic(Scroll)	Hermetic(Scroll)	Hermetic(Scroll)	Hermetic(Scroll)	Hermetic(Scroll)	Hermetic(Scroll)	Hermetic(Scroll)	Hermetic(Scroll)
	Rated air volume	m³/min	405	207+263	256+263	263+263	256+329	263+329	263+348	329+329	329+348	348+348	348+375
Outdoor unit Fan	Number of Fan Motors	-	2+1	2+2	2+2	2+2	2+2	2+2	2+2	2+2	2+2	2+2	2+2
	Motor output	kW	0.71×2	0.38×2+0.51	0.38×2+0.35×2	(0.38×2)×2	0.4×2+0.35×2	0.4×2+0.38×2	0.47×2+0.38×2	(0.4×2)×2	0.47×2+0.4×2	(0.47×2)×2	0.58×2+0.47×2
Main pipe size	Gas piping	mm	31.75	31.75	31.75	38.1	38.1	38.1	38.1	38.1	38.1	38.1	38.1
	Main pipe size Liquid piping	mm	19.05	19.05	19.05	19.05	19.05	19.05	19.05	19.05	19.05	19.05	19.05
	Tubing connection method		Brazing connection	Brazing connection	Brazing connection	Brazing connection	Brazing connection	Brazing connection	Brazing connection	Brazing connection	Brazing connection	Brazing connection	Brazing connection
Operating temperature range		°C DB	-5°C~52°C	-5°C~52°C	-5°C~52°C	-5°C~52°C	-5°C~52°C	-5°C~52°C	-5°C~52°C	-5°C~52°C	-5°C~52°C	-5°C~52°C	-5°C~52°C
Maximum External static pressure		Pa	80	80	80	80	80	80	80	80	80	80	80
Maximum Total piping length		m	1,000	1,000	1,000	1,000	1,000	1,000	1,000	1,000	1,000	1,000	1,000
Refrigerant	Type		R410A	R410A	R410A	R410A	R410A	R410A	R410A	R410A	R410A	R410A	R410A
	Initial charge amount	kg	11.6	18.5	19.7	20.4	20.7	21.4	21.8	22.4	22.8	23.2	23.2
	Refrigerant Maximum additional charge amount	kg	56	76	80	80	86	86	86	92	92	92	102
	Refrigerant control mode		Microcomputer-controlled electronic expansion valve				Microcomputer-controlled electronic expansion valve						
Refrigerant oil	Type	-	FVC68D	FVC68D	FVC68D	FVC68D	FVC68D	FVC68D	FVC68D	FVC68D	FVC68D	FVC68D	FVC68D
	Charge amount	L	8.4	12.9	13.8	13.8	15.3	15.3	15.3	16.8	16.8	16.8	16.8
Connected capacity ratio		%	50~200%	50~200%	50~200%	50~200%	50~200%	50~200%	50~200%	50~200%	50~200%	50~200%	50~200%
With Indoor Unit	Maximum Number of connectable units (recommended number of units)	-	64 (32)	64 (32)	64 (32)	64 (32)	64 (38)	64 (38)	64 (38)	64 (38)	64 (38)	64 (38)	64 (38)
	Connectable minimum capacity	HP Class	0.6	0.6	0.6	0.6	0.6	0.6	0.6	0.6	0.6	0.6	0.6

Specifications Cooling

LL



LL



LL



LLM



LLL



Capacity range	Unit	52HP	54HP	56HP	58HP	60HP	62HP	64HP	66HP	68HP	70HP	72HP	
Outdoor unit model		RAS-520CNCLLI	RAS-540CNCLLI	RAS-560CNCLLI	RAS-580CNCLLI	RAS-600CNCLLI	RAS-620CNCLLI	RAS-640CNCLLI	RAS-660CNCLLI	RAS-680CNCLLI	RAS-700CNCLLI	RAS-720CNCLLI	
Combination of modules		RAS-260CNCLLI RAS-260CNCLLI	RAS-280CNCLLI RAS-260CNCLLI	RAS-280CNCLLI RAS-280CNCLLI	RAS-300CNCLLI RAS-280CNCLLI	RAS-300CNCLLI RAS-300CNCLLI	RAS-220CNCLLI RAS-220CNCLLI RAS-180CNCLLI	RAS-240CNCLLI RAS-220CNCLLI RAS-180CNCLLI	RAS-240CNCLLI RAS-240CNCLLI RAS-180CNCLLI	RAS-240CNCLLI RAS-220CNCLLI RAS-220CNCLLI	RAS-240CNCLLI RAS-240CNCLLI RAS-220CNCLLI	RAS-240CNCLLI RAS-240CNCLLI RAS-240CNCLLI	
Power supply	-	3N~ 380-415V 50Hz	3N~ 380-415V 50Hz	3N~ 380-415V 50Hz	3N~ 380-415V 50Hz	3N~ 380-415V 50Hz	3N~ 380-415V 50Hz	3N~ 380-415V 50Hz	3N~ 380-415V 50Hz	3N~ 380-415V 50Hz	3N~ 380-415V 50Hz	3N~ 380-415V 50Hz	
Cooling capacity	kW	146	150.5	155	161.5	168	173.4	178.9	184.4	190	195.5	201	
Outer dimensions (W x D x H)	mm	3,240×775×1,805	3,240×775×1,805	3,240×775×1,805	3,240×775×1,805	3,240×775×1,805	4,480×775×1,805	4,480×775×1,805	4,480×775×1,805	4,870×775×1,805	4,870×775×1,805	4,870×775×1,805	
Weight	Net weight	379+379	379+379	379+379	379+379	379+379	277+360+360	277+360+360	277+360+360	360+360+360	360+360+360	360+360+360	
	Gross weight	402+402	402+402	402+402	402+402	402+402	297+383+383	297+383+383	297+383+383	383+383+383	383+383+383	383+383+383	
Noise	Cooling rating	SPL (Full-anechoic) dB(A)	65	65	65	67	68	66	66	66	66	66	
	Night shift mode (noise reduction setting)	SPL (Full-anechoic) dB(A)	63	63	63	63	63	61	61	61	62	62	
Compressor	Compressor type	-	Hermetic(Scroll)	Hermetic(Scroll)	Hermetic(Scroll)	Hermetic(Scroll)	Hermetic(Scroll)	Hermetic(Scroll)	Hermetic(Scroll)	Hermetic(Scroll)	Hermetic(Scroll)	Hermetic(Scroll)	
Outdoor unit Fan	Rated air volume	m ³ /min	375+375	375+375	375+375	375+405	405+405	263+329+329	263+329+348	263+329+348	329+329+348	329+348+348	
	Number of Fan Motors	-	2+2	2+2	2+2	2+2	2+2	2+2+2	2+2+2	2+2+2	2+2+2	2+2+2	
Main pipe size	Motor output	kW	(0.58×2)×2	0.58×2+0.58×2	(0.58×2)×2	0.71×2+0.58×2	(0.71×2)×2	(0.4×2)×2+0.38×2	0.47×2+0.4×2+0.38×2	(0.47×2)×2+0.38×2	0.47×2+(0.4×2)×2	(0.47×2)×2+0.4×2	
	Gas piping	mm	38.1	38.1	44.45	44.45	44.45	44.45	44.45	44.45	44.45	44.45	
	Liquid piping	mm	19.05	19.05	19.05	19.05	19.05	19.05	19.05	19.05	22.2	22.2	
	Tubing connection method	-	Brazing connection	Brazing connection	Brazing connection	Brazing connection	Brazing connection	Brazing connection	Brazing connection	Brazing connection	Brazing connection	Brazing connection	
Operating temperature range	°C DB	-5°C~52°C	-5°C~52°C	-5°C~52°C	-5°C~52°C	-5°C~52°C	-5°C~52°C	-5°C~52°C	-5°C~52°C	-5°C~52°C	-5°C~52°C	-5°C~52°C	
Maximum External static pressure	Pa	80	80	80	80	80	80	80	80	80	80	80	
Maximum Total piping length	m	1,000	1,000	1,000	1,000	1,000	1,000	1,000	1,000	1,000	1,000	1,000	
Refrigerant	Type	-	R410A	R410A	R410A	R410A	R410A	R410A	R410A	R410A	R410A	R410A	
	Initial charge amount	kg	23.2	23.2	23.2	23.2	23.2	32.6	33	33.4	34	34.4	
	Maximum additional charge amount	kg	112	112	112	112	112	132	132	132	138	138	
	Refrigerant control mode	-	Microcomputer-controlled electronic expansion valve						Microcomputer-controlled electronic expansion valve				
Refrigerant oil	Type	-	FVC68D	FVC68D	FVC68D	FVC68D	FVC68D	FVC68D	FVC68D	FVC68D	FVC68D	FVC68D	
	Charge amount	L	16.8	16.8	16.8	16.8	16.8	23.7	23.7	23.7	25.2	25.2	
With Indoor Unit	Connected capacity ratio	%	50~200%	50~200%	50~180%	50~150%	50~150%	50~150%	50~150%	50~150%	50~150%	50~150%	
	Maximum Number of connectable units (recommended number of units)	-	64 (38)	64 (38)	64 (38)	64 (38)	64 (38)	64 (38)	64 (38)	64 (38)	64 (38)	64 (38)	
	Connectable minimum capacity	HP Class	0.6	0.6	0.6	0.6	0.6	0.6	0.6	0.6	0.6	0.6	

Specifications Cooling

LLL



LLLL



LLLL



Capacity range	Unit	74HP	76HP	78HP	80HP	82HP	84HP	86HP	88HP	90HP	92HP	94HP
Outdoor unit model		RAS-740CNCCLI	RAS-760CNCCLI	RAS-780CNCCLI	RAS-800CNCCLI	RAS-820CNCCLI	RAS-840CNCCLI	RAS-860CNCCLI	RAS-880CNCCLI	RAS-900CNCCLI	RAS-920CNCCLI	RAS-940CNCCLI
Combination of modules		RAS-260CNCCLI RAS-240CNCCLI RAS-240CNCCLI	RAS-260CNCCLI RAS-260CNCCLI RAS-240CNCCLI	RAS-260CNCCLI RAS-260CNCCLI RAS-260CNCCLI	RAS-280CNCCLI RAS-260CNCCLI RAS-260CNCCLI	RAS-280CNCCLI RAS-280CNCCLI RAS-260CNCCLI	RAS-280CNCCLI RAS-280CNCCLI RAS-280CNCCLI	RAS-300CNCCLI RAS-280CNCCLI RAS-280CNCCLI	RAS-300CNCCLI RAS-300CNCCLI RAS-280CNCCLI	RAS-300CNCCLI RAS-300CNCCLI RAS-300CNCCLI	RAS-240CNCCLI RAS-240CNCCLI RAS-220CNCCLI RAS-220CNCCLI	RAS-240CNCCLI RAS-240CNCCLI RAS-240CNCCLI RAS-220CNCCLI
Power supply	-	3N~ 380-415V 50Hz	3N~ 380-415V 50Hz	3N~ 380-415V 50Hz	3N~ 380-415V 50Hz	3N~ 380-415V 50Hz	3N~ 380-415V 50Hz	3N~ 380-415V 50Hz	3N~ 380-415V 50Hz	3N~ 380-415V 50Hz	3N~ 380-415V 50Hz	3N~ 380-415V 50Hz
Cooling capacity	kW	207	213	219	223.5	228	232.5	239	245.5	252	257	262.5
Outer dimensions (W x D x H)	mm	4,870×775×1,805	4,870×775×1,805	4,870×775×1,805	4,870×775×1,805	4,870×775×1,805	4,870×775×1,805	4,870×775×1,805	4,870×775×1,805	4,870×775×1,805	6,500×775×1,805	6,500×775×1,805
Weight	Net weight	kg	360+360+379	360+379+379	379+379+379	379+379+379	379+379+379	379+379+379	379+379+379	379+379+379	360+360+360+360	360+360+360+360
	Gross weight	kg	383+383+402	383+402+402	402+402+402	402+402+402	402+402+402	402+402+402	402+402+402	402+402+402	402+402+402	383+383+383+383
Noise	Cooling rating	SPL (Full-anechoic) dB(A)	66	66	67	67	67	67	67	68	69	70
	Night shift mode (noise reduction setting)	SPL (Full-anechoic) dB(A)	63	64	65	65	65	65	65	65	65	63
Compressor	Compressor type	-	Hermetic(Scroll)	Hermetic(Scroll)	Hermetic(Scroll)	Hermetic(Scroll)	Hermetic(Scroll)	Hermetic(Scroll)	Hermetic(Scroll)	Hermetic(Scroll)	Hermetic(Scroll)	Hermetic(Scroll)
Outdoor unit Fan	Rated air volume	m ³ /min	348+348+375	348+375+375	375+375+375	375+375+375	375+375+375	375+375+375	375+375+375	375+375+405	375+405+405	405+405+405
	Number of Fan Motors	-	2+2+2	2+2+2	2+2+2	2+2+2	2+2+2	2+2+2	2+2+2	2+2+2+2	2+2+2+2	2+2+2+2
	Motor output	kW	0.58×2+(0.47×2)×2	(0.58×2)×2+0.47×2	(0.58×2)×3	0.58×2+(0.58×2)×2	(0.58×2)×2+0.58×2	(0.58×2)×3	0.71×2+(0.58×2)×2	(0.71×2)×2+0.58×2	(0.71×2)×3	(0.47×2)×2+(0.4×2)×2
Main pipe size	Gas piping	mm	50.8	50.8	50.8	50.8	50.8	50.8	50.8	50.8	50.8	50.8
	Liquid piping	mm	22.2	22.2	22.2	22.2	22.2	22.2	22.2	25.4	25.4	25.4
	Tubing connection method	-	Brazing Connection	Brazing Connection	Brazing Connection	Brazing Connection	Brazing Connection	Brazing Connection	Brazing Connection	Brazing Connection	Brazing Connection	Brazing Connection
Operating temperature range	°C DB	-5°C~52°C	-5°C~52°C	-5°C~52°C	-5°C~52°C	-5°C~52°C	-5°C~52°C	-5°C~52°C	-5°C~52°C	-5°C~52°C	-5°C~52°C	-5°C~52°C
Maximum External static pressure	Pa	80	80	80	80	80	80	80	80	80	80	80
Maximum Total piping length	m	1,000	1,000	1,000	1,000	1,000	1,000	1,000	1,000	1,000	1,000	1,000
Refrigerent	Type		R410A	R410A	R410A	R410A	R410A	R410A	R410A	R410A	R410A	R410A
	Initial charge amount	kg	34.8	34.8	34.8	34.8	34.8	34.8	34.8	34.8	34.8	45.6
	Refrigerant Maximum additional charge amount	kg	148	158	168	168	168	168	168	168	168	184
	Refrigerant control mode		Microcomputer-controlled electronic expansion valve				Microcomputer-controlled electronic expansion valve					
Refrigerant oil	Type	-	FVC68D	FVC68D	FVC68D	FVC68D	FVC68D	FVC68D	FVC68D	FVC68D	FVC68D	FVC68D
	Charge amount	L	25.2	25.2	25.2	25.2	25.2	25.2	25.2	25.2	33.6	33.6
With Indoor Unit	Connected capacity ratio	%	50~150%	50~150%	50~150%	50~150%	50~150%	50~150%	50~150%	50~150%	50~150%	50~150%
	Maximum Number of connectable units (recommended number of units)	-	64 (38)	64 (38)	64 (38)	64 (38)	64 (38)	64 (38)	64 (38)	64 (38)	64 (38)	64 (38)
	Connectable minimum capacity	HP Class	0.6	0.6	0.6	0.6	0.6	0.6	0.6	0.6	0.6	0.6

Specifications Cooling

LLLL



Capacity range	Unit	96HP	98HP	100HP	102HP	104HP	106HP	108HP	110HP	112HP	114HP	116HP	118HP	120HP
Outdoor unit model		RAS-960CNCCLI	RAS-980CNCCLI	RAS-H00CNCCLI	RAS-H02CNCCLI	RAS-H04CNCCLI	RAS-H06CNCCLI	RAS-H08CNCCLI	RAS-H10CNCCLI	RAS-H12CNCCLI	RAS-H14CNCCLI	RAS-H16CNCCLI	RAS-H18CNCCLI	RAS-H20CNCCLI
Combination of modules		RAS-240CNCCLI	RAS-260CNCCLI	RAS-260CNCCLI	RAS-260CNCCLI	RAS-260CNCCLI	RAS-280CNCCLI	RAS-280CNCCLI	RAS-280CNCCLI	RAS-280CNCCLI	RAS-300CNCCLI	RAS-300CNCCLI	RAS-300CNCCLI	RAS-300CNCCLI
		RAS-240CNCCLI	RAS-240CNCCLI	RAS-260CNCCLI	RAS-260CNCCLI	RAS-260CNCCLI	RAS-260CNCCLI	RAS-280CNCCLI	RAS-280CNCCLI	RAS-280CNCCLI	RAS-280CNCCLI	RAS-300CNCCLI	RAS-300CNCCLI	RAS-300CNCCLI
		RAS-240CNCCLI	RAS-240CNCCLI	RAS-240CNCCLI	RAS-260CNCCLI	RAS-260CNCCLI	RAS-260CNCCLI	RAS-260CNCCLI	RAS-280CNCCLI	RAS-280CNCCLI	RAS-280CNCCLI	RAS-280CNCCLI	RAS-300CNCCLI	RAS-300CNCCLI
		RAS-240CNCCLI	RAS-240CNCCLI	RAS-240CNCCLI	RAS-240CNCCLI	RAS-260CNCCLI	RAS-260CNCCLI	RAS-260CNCCLI	RAS-260CNCCLI	RAS-260CNCCLI	RAS-280CNCCLI	RAS-280CNCCLI	RAS-280CNCCLI	RAS-280CNCCLI
Power supply	-	3N~ 380-415V 50Hz	3N~ 380-415V 50Hz	3N~ 380-415V 50Hz	3N~ 380-415V 50Hz	3N~ 380-415V 50Hz	3N~ 380-415V 50Hz	3N~ 380-415V 50Hz	3N~ 380-415V 50Hz	3N~ 380-415V 50Hz	3N~ 380-415V 50Hz	3N~ 380-415V 50Hz	3N~ 380-415V 50Hz	3N~ 380-415V 50Hz
Cooling capacity	kW	268	274	280	286	292	296.5	301	305.5	310	316.5	323	329.5	329.5
Outer dimensions (W x D x H)	mm	6,500×775×1,805	6,500×775×1,805	6,500×775×1,805	6,500×775×1,805	6,500×775×1,805	6,500×775×1,805	6,500×775×1,805	6,500×775×1,805	6,500×775×1,805	6,500×775×1,805	6,500×775×1,805	6,500×775×1,805	6,500×775×1,805
Weight	Net weight	kg	360+360+360+360	360+360+360+379	360+360+379+379	360+379+379+379	379+379+379+379	379+379+379+379	379+379+379+379	379+379+379+379	379+379+379+379	379+379+379+379	379+379+379+379	379+379+379+379
	Gross weight	kg	383+383+383+383	383+383+383+402	383+383+402+402	383+402+402+402	402+402+402+402	402+402+402+402	402+402+402+402	402+402+402+402	402+402+402+402	402+402+402+402	402+402+402+402	402+402+402+402
Noise	Cooling rating	SPL (Full-anechoic) dB(A)	67	67	68	68	68	68	68	68	68	69	70	70
	Night shift mode (noise reduction setting)	SPL (Full-anechoic) dB(A)	63	64	65	65	66	66	66	66	66	66	66	66
Compressor	Compressor type	-	Hermetic(Scroll)	Hermetic(Scroll)	Hermetic(Scroll)	Hermetic(Scroll)	Hermetic(Scroll)	Hermetic(Scroll)	Hermetic(Scroll)	Hermetic(Scroll)	Hermetic(Scroll)	Hermetic(Scroll)	Hermetic(Scroll)	Hermetic(Scroll)
Outdoor unit Fan	Rated air volume	m ³ /min	348+348+348+348	348+348+348+375	348+348+375+375	348+375+375+375	375+375+375+375	375+375+375+375	375+375+375+375	375+375+375+375	375+375+375+375	375+375+405+405	375+405+405+405	405+405+405+405
	Number of Fan Motors	-	2+2+2+2	2+2+2+2	2+2+2+2	2+2+2+2	2+2+2+2	2+2+2+2	2+2+2+2	2+2+2+2	2+2+2+2	2+2+2+2	2+2+2+2	2+2+2+2
	Motor output	kW	(0.47×2)×4	0.58×2+(0.47×2)×3	(0.58×2)×2+(0.47×2)×2	(0.58×2)×3+0.47×2	(0.58×2)×4	0.58×2+(0.58×2)×3	(0.58×2)×2+(0.58×2)×2	(0.58×2)×3+0.58×2	(0.58×2)×4	0.71×2+(0.58×2)×3	(0.71×2)×2+(0.58×2)×2	(0.71×2)×3+(0.58×2)
Main pipe size	Gas piping	mm	50.8	54	54	54	54	54	54	54	54	54	54	54
	Liquid piping	mm	25.4	25.4	25.4	25.4	25.4	25.4	25.4	25.4	28.58	28.58	28.58	28.58
	Tubing connection method	-	Brazing connection	Brazing connection	Brazing connection	Brazing connection	Brazing connection	Brazing connection	Brazing connection	Brazing connection	Brazing connection	Brazing connection	Brazing connection	Brazing connection
Operating temperature range	°C DB	-5°C-52°C	-5°C-52°C	-5°C-52°C	-5°C-52°C	-5°C-52°C	-5°C-52°C	-5°C-52°C	-5°C-52°C	-5°C-52°C	-5°C-52°C	-5°C-52°C	-5°C-52°C	-5°C-52°C
Maximum External static pressure	Pa	80	80	80	80	80	80	80	80	80	80	80	80	80
Maximum Total piping length	m	1,000	1,000	1,000	1,000	1,000	1,000	1,000	1,000	1,000	1,000	1,000	1,000	1,000
Refrigerent	Type		R410A	R410A	R410A	R410A	R410A	R410A	R410A	R410A	R410A	R410A	R410A	R410A
	Initial charge amount	kg	46.4	46.4	46.4	46.4	46.4	46.4	46.4	46.4	46.4	46.4	46.4	46.4
	Refrigerant Maximum additional charge amount	kg	184	194	204	214	224	224	224	224	224	224	224	224
	Refrigerant control mode	-	Microcomputer-controlled electronic expansion valve						Microcomputer-controlled electronic expansion valve					
Refrigerant oil	Type	-	FVC68D	FVC68D	FVC68D	FVC68D	FVC68D	FVC68D	FVC68D	FVC68D	FVC68D	FVC68D	FVC68D	FVC68D
	Charge amount	L	33.6	33.6	33.6	33.6	33.6	33.6	33.6	33.6	33.6	33.6	33.6	33.6
With Indoor Unit	Connected capacity ratio	%	50~150%	50~150%	50~150%	50~150%	50~150%	50~150%	50~150%	50~150%	50~150%	50~150%	50~150%	50~150%
	Maximum Number of connectable units (recommended number of units)	-	64 (38)	64 (38)	64 (38)	64 (38)	64 (38)	64 (38)	64 (38)	64 (38)	64 (38)	64 (38)	64 (38)	64 (38)
	Connectable minimum capacity	HP Class	0.6	0.6	0.6	0.6	0.6	0.6	0.6	0.6	0.6	0.6	0.6	0.6



Option

1) Piping Connection Kit

*For Heat Pump (2 Pipes)

Model name	Applicable Outdoor Unit		Remarks
	Combined X modules	air365 Max	
MC-NP21SA1	2	30 to 48 HP	for Gas : 1 for Liquid : 1
MC-NP22TA		50 to 56 HP	
MC-NP31TA	3	58 to 84 HP	for Gas : 2 for Liquid : 2
MC-NP40TA	4	86 to 112 HP	for Gas : 3 for Liquid : 3

2) Multi-Kit

*For Heat Pump (2 Pipes)

Line branch

First Branch

(First branch) Model Name	Outdoor Unit HP	After First Branch Multi Kit Code of G3	Total Indoor Unit HP
MW-NP282A3 or E-102SNK/K1	8, 10	MW-NP282A3 or E-102SNK/K1	< 11.99
MW-NP452A3 or E-162SNK/K1	12 to 16	MW-NP452A3 or E-162SNK/K1	12 to 17.99
MW-NP692A3 or E-242SNK/K1	18 to 24	MW-NP692A3 or E-242SNK/K1	18 to 25.99
MW-NP902A3 or E-302SNK/K1	26 to 54	MW-NP902A3 or E-302SNK/K1	26 to 55.99
MW-NP2682A3 or E682SNQ	56 to 112	MW-NP2682A3 or E682SNQ	≥ 56

1) Piping Connection Kit

*For Cooling Only (2 Pipes)

Model name	Applicable Outdoor Unit		Remarks
	Combined X modules	air365 Max	
MC-NP21SA1	2	32 to 48 HP	for Gas : 1 for Liquid : 1
MC-NP22TA		50 to 60 HP	
MC-NP31TA	3	62 to 90 HP	for Gas : 2 for Liquid : 2
MC-NP40TA	4	92 to 120 HP	for Gas : 3 for Liquid : 3

2) Multi-Kit

*For Cooling Only (2 Pipes)

Line branch

First Branch

(First branch) Model Name	Outdoor Unit HP	After First Branch Model Name	Total Indoor Unit HP
MW-NP282A3 or E-102SNK/K1	8, 10	MW-NP282A3 or E-102SNK/K1	< 12
MW-NP452A3 or E-162SNK/K1	12 to 16	MW-NP452A3 or E-162SNK/K1	12 to 17.99
MW-NP692A3 or E-242SNK/K1	18 to 24	MW-NP692A3 or E-242SNK/K1	18 to 25.99
MW-NP902A3 or E-302SNK/K1	26 to 54	MW-NP902A3 or E-302SNK/K1	26 to 55.99
MW-NP2682A3 or E682SNQ	56 to 120	MW-NP2682A3 or E682SNQ	≥ 56

Indoor units



Comfort first

Give each space its own indoor unit. Our wide range of units can meet any type of requirement and space layout, and seamlessly integrate with interiors.

With seamless and quiet operation, your customers can relax and enjoy the air while using only the amount energy needed. Advanced functions such as GentleCool and AutoBoost allow you to customize the air in each space to suit your customers' preferences, while smart design minimizes the need for maintenance.

57 PRODUCT DETAIL

57 Ceiling cassettes

- 57 Silent-Iconic™
 - 59 4 Way cassette
 - 61 4 Way compact cassette
 - 63 2 Way cassette
 - 65 1 Way cassette
-

67 In-the-ceiling units

- 67 In-the-ceiling
 - 68 In-the-ceiling (Duct type)
-

69 Others

- 69 Floor concealed
 - 70 Floor/Ceiling convertible
 - 71 Hi wall
-

73 SPECIFICATIONS

Choice for perfect indoor experience

Indoor Unit Category	HP									
	0.8	1.0	1.5	2.0	2.5	3.0	4.0	5.0	6.0	
Ceiling Cassette										
4 way cassette		✓	✓	✓	✓	✓	✓	✓	✓	✓
Silent-Iconic™		✓	✓	✓	✓	✓	✓	✓	✓	✓
4 way compact cassette		✓	✓	✓	✓					
2 way cassette	✓	✓	✓	✓	✓	✓	✓	✓	✓	✓
1 way cassette*		✓		✓	✓					
In-The-Ceiling & Concealed										
In-the-ceiling		✓	✓	✓	✓					
In-the-ceiling (Duct type)*		✓	✓	✓	✓	✓	✓	✓	✓	✓
Floor concealed		✓	✓	✓	✓					
Exposed										
Floor/Ceiling convertible				✓	✓	✓	✓	✓		
Hi wall**	✓	✓	✓	✓	✓	✓	✓			

*1 Way Cassette also available in 1.3 HP and 1.6 HP.

*Product images shown are for reference only and data can be changed without prior notice.

*In-The-Ceiling (Duct type) high static models are available in 8,10,12,16 & 20 HP.

**Hi Wall unit is available in 1.3 HP.

Key information

Ceiling Cassette

Silent-Iconic™

- The indoor air conditioning unit that makes a statement without making “noise”
- Individual 4 way louver control
- Drop down grille up to 4m

4 way cassette

- Individual 4 way louver control
- Motion Sensor technology (optional)
- Higher ceiling installation (up to 5.5m in cooling mode)

4 way compact cassette

- Compact grid 600X600mm
- Quieter operation (as low as 24.5 dB(A))
- Higher ceiling installation (up to 4.6m in cooling mode)

2 way cassette

- Individual louver option
- Motion Sensor technology (optional)
- Higher ceiling installation (up to 4.6m in cooling mode)

1 way cassette

- Compact size: Height- 192mm & Depth - 470mm
- Quiet operation (as low as 27 dB(A))
- Max. drainage height up to 1200mm

In-The-Ceiling & Concealed

In-the-ceiling

- Ease of installation with 192mm height
- Compact width starting from 700mm

In-the-ceiling (Duct type)

- Broad range of ESP up to 50 Pa with long and short duct variants.
- Ease of installation and flexible duct connection
- Higher CFM
- Flexible mirror installation for hotel application

Floor concealed

- Compact height up to 620mm
- Can be hidden away without ceiling void

Exposed

Floor/Ceiling convertible

- Easy installation
- It can be mounted on floor or suspended in ceiling as per the choice and space availability.

Hi wall

- iClean+ technology
- Motion Sensor technology
- Wide range of capacity from 0.8 HP to 4 HP



Silent-Iconic™

4-Way Cassette Design Panel

A design panel in harmony with the space that responds to the needs of architectural designers



reddot winner 2021
best of the best

[Silent-iconic] receives Red Dot: Best of the Best for ground-breaking design quality



The design is well-matched to the space

It is designed to harmonize with the space by creating the central part to be a blind shaped air-inlet port and reducing its occupied presence by darkening the air-outlet port.

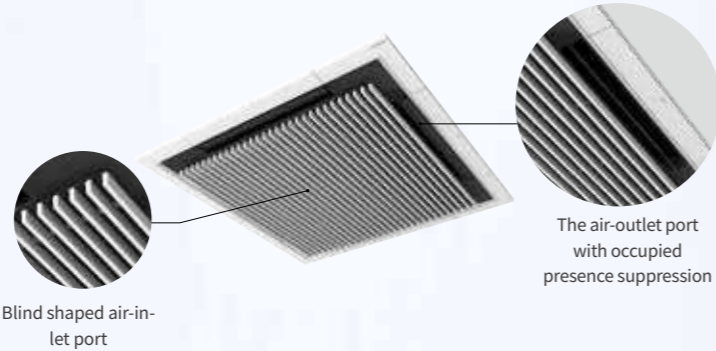

Blind shaped air-inlet port

The air-outlet port with occupied presence suppression

Tomohiko Sato

Hitachi, Ltd. Product Design Department, Senior Designer



The designer graduated from University in the United Kingdom and soon after, he joined a London based design studio, working across a wide variety of disciplines including furniture, interior and the public realm. Currently, he dedicates himself to air conditioning design, working as a Senior Designer in the Hitachi product design department in Hitachi, Ltd.

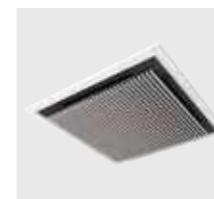
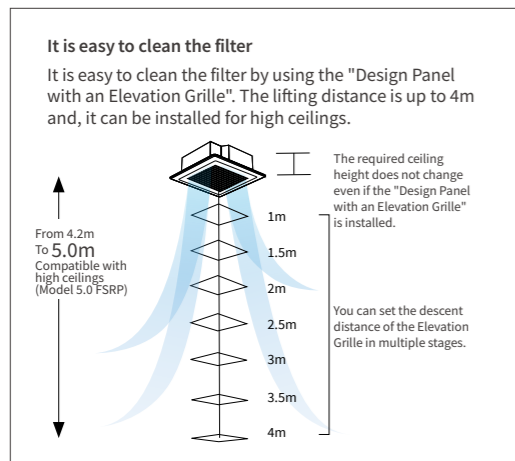

1. Scan the QR code¹⁷ and open the web page

Display the web page with a QR code, URL, etc.



2. Tap the icon

Tap the icon displayed at the bottom right of the 3D Viewer. If the icon is not displayed, please unhide it in Safari or check the OS version.



3. AR mode is activated

Hold out the camera toward the ceiling and get it to detect the environment by moving it in a circular motion. You may not be able to scan a single-colored ceiling so scan a place where objects such as downlights or ceiling ventilation fans are installed.



4. Adjustment of placement location

You can shift then move it with a single finger, and rotate or zoom it out/zoom it in with two fingers to adjust the size that fits the space. There is also a capture button, so you can take and share the pictures you have placed.

4 way cassette

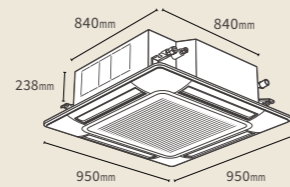

1.0-2.5 HP

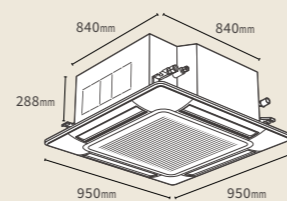

3.0-6.0 HP

Motion Sensor technology

Motion Sensor technology comes with the ability to ensure you get equal attention for equal cooling comfort and enjoy higher energy savings. It identifies the number of people and directs airflow as per the requirement. In case of human absence, the sensor automatically switches the AC off, reducing wastage of energy.

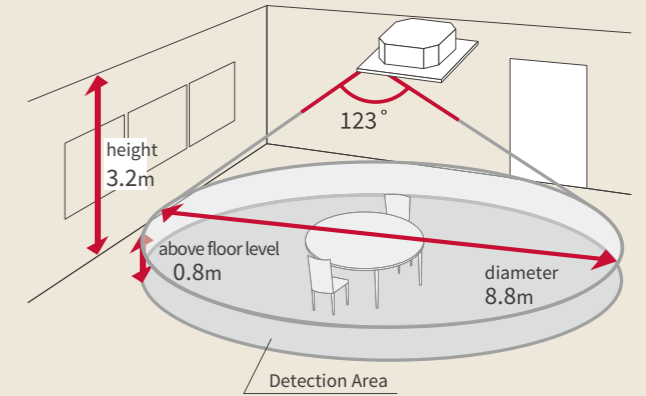

* Motion Sensor detecting area dimension
 7.0m = 1.0-3.0FSKDN1Q
 8.8m = 4.0-6.0FSKDN1Q
 * Motion Sensor is an optional feature (PS-MSK2) with use of Advanced Wired Controller (PC-ARF/ PC-ARF1)

Individual 4 way louver control

Have control of the airflow with 4 way individual louver. It's louver can be adjusted as per the requirement in each zone and the wastage of air to a dead zone can also be avoided.

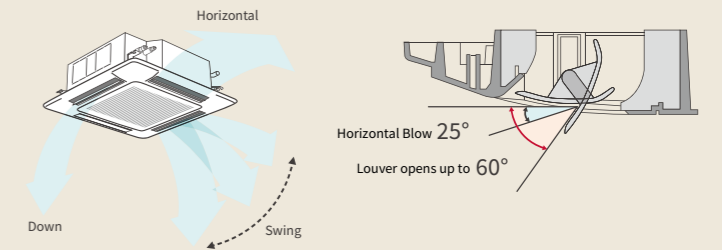

* This feature is compatible with wired remote controller (PC-ARF/ PC-ARF1/ HCWA10NEGQ)

Engineered for high ceiling space

Hitachi's Cassette AC are engineered to place at higher ceiling space such as car showroom space, banquets, and more.

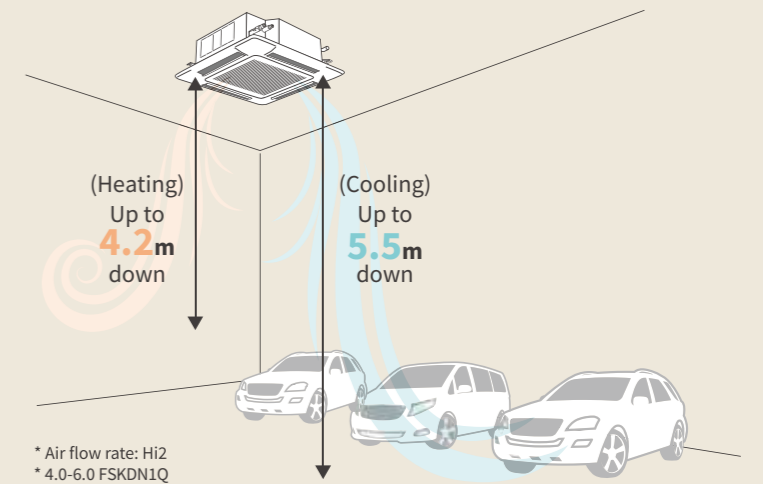

* Air flow rate: Hi2
 * 4.0-6.0 FSKDN1Q

Standard drain pump with 850 mm lift

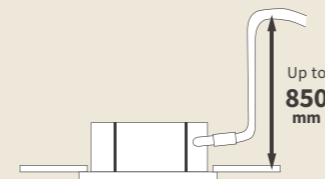

Direct attachment of round-ducts available

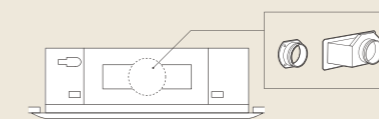

Easy fine-tune for installment height

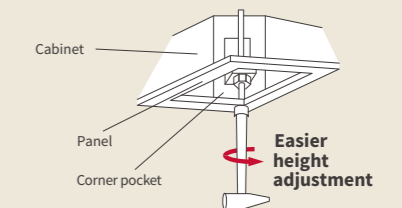

4 way compact cassette

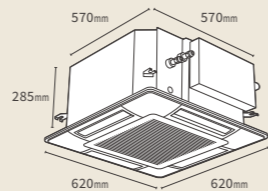

1.0~2.5 HP

Stylishly modern

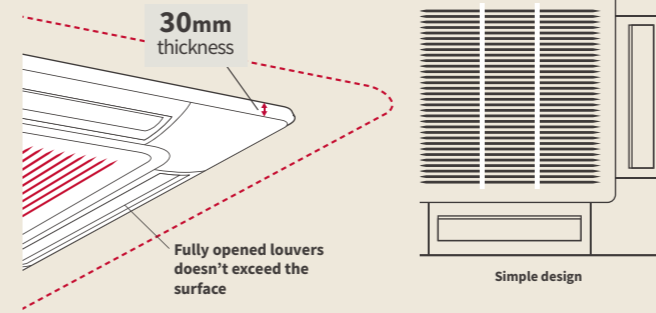

Compact design

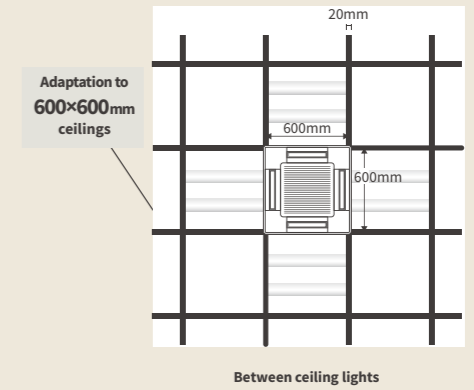

Engineered for high ceiling space

Hitachi's Compact Cassette AC are engineered to place at higher ceiling space such as car showroom space, banquets, and more. It comes with standard drain pump of 850mm lift.

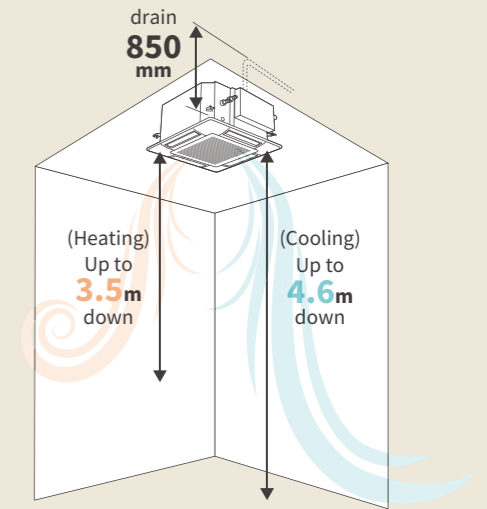

* Air flow rate: Hi2
* 2.0-2.5 FSRE

Antibacterial drain pan

Adopting new antibacterial agent of drain pan for cleaner air and ease of maintenance.



Inhibit the generation of slime

Silent operation

IDU Capacity HP(Class)	1	1.5	2	2.5
Sound pressure level (dB(A))	24.5	27.5	31	35

*Air flow rate: Low

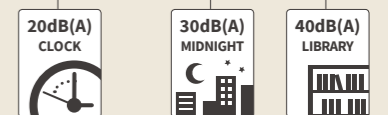

2 way cassette



Motion Sensor technology

Motion Sensor technology comes with the ability to ensure you get equal attention for equal cooling comfort and enjoy higher energy savings. It identifies the number of people and directs airflow as per the requirement. In case of human absence, the sensor automatically switches the AC off, reducing wastage of energy.

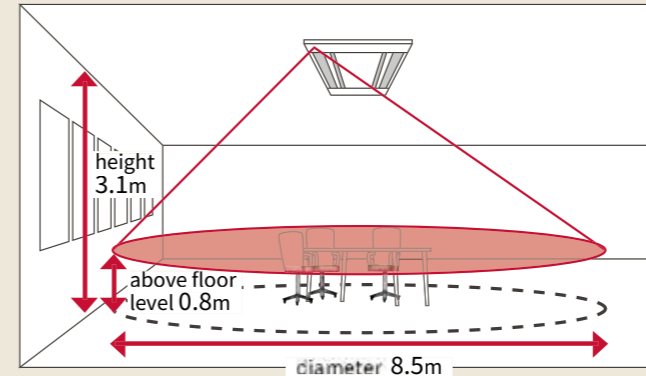

* Motion Sensor is an optional feature (SOR-NED) with use of advanced wired controller (PC-ARF/ PC-ARF1)

Engineered for high ceiling space

Hitachi's 2 Way Cassette AC is engineered to place at higher ceiling space such as car showroom space, banquets, and more. It comes with standard drain pump with 850mm lift.

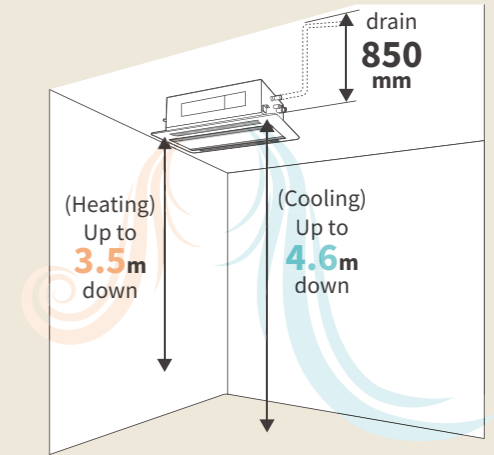

* Air flow rate: Hi2
* 2.0-6.0 FSN3

Individual louver control

Have control of the airflow with Individual louver. Its louver can be adjusted as per the requirement in each zone and the wastage of air to a dead zone can also be avoided.

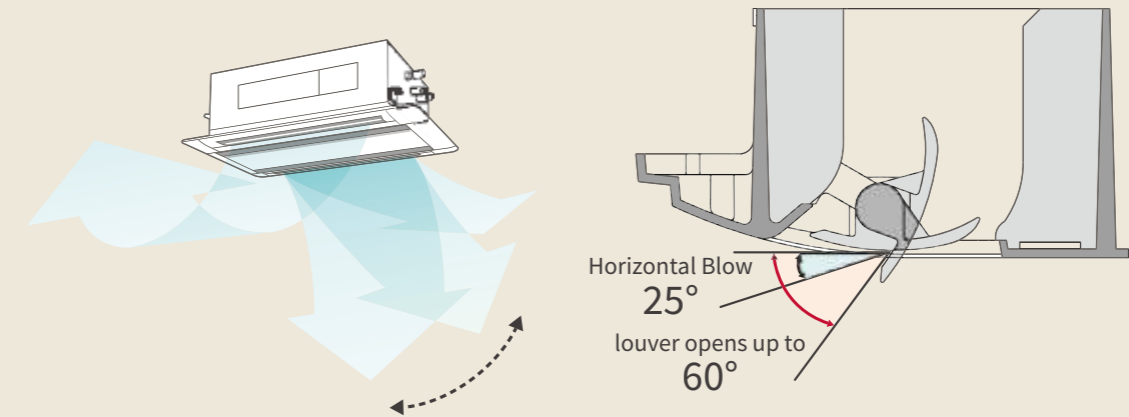

Easy fine-tune for installment height

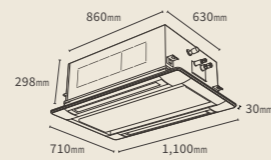
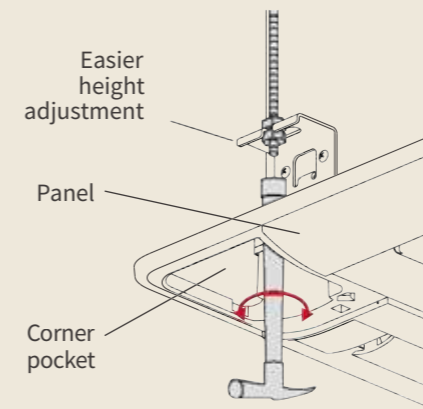

0.8-3.0 HP

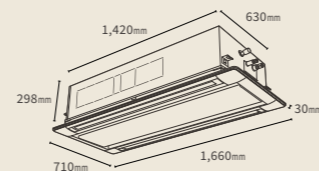

4.0-6.0 HP

1 way cassette

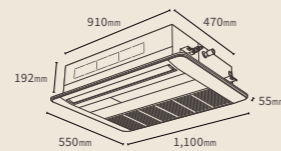

1.0~1.6 HP

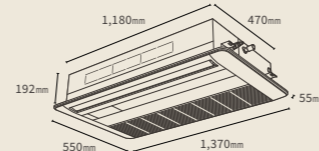

2.0~2.5 HP

3D air flow

3 directional air flow with broad air deflector design to have adjustable wind direction as per your need for a comfortable environment.

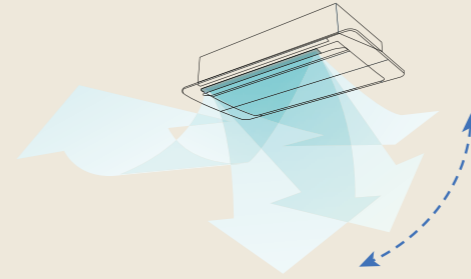

Sleek and compact design



Standard drain pump

Standard equipped drain pump with maximum drainage height up to 1200mm

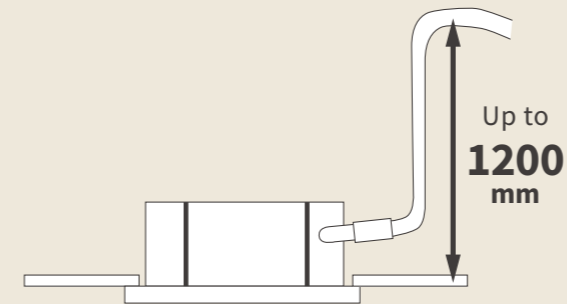

Silent operation

IDU capacity HP(Class)	1	1.3	1.6	2	2.5
Sound pressure level (dB(A))	27	28	30	31	32

*Air flow rate: Low

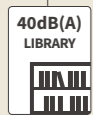
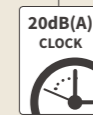

Adjustable air speed

Adoption of the efficient DC motor and the optimized duct design assure the smooth air flow.

Fresh air provision (Optional)

The unit can introduce fresh air from the external environment. With the filter facility, the air quality is guaranteed.

In-the-ceiling

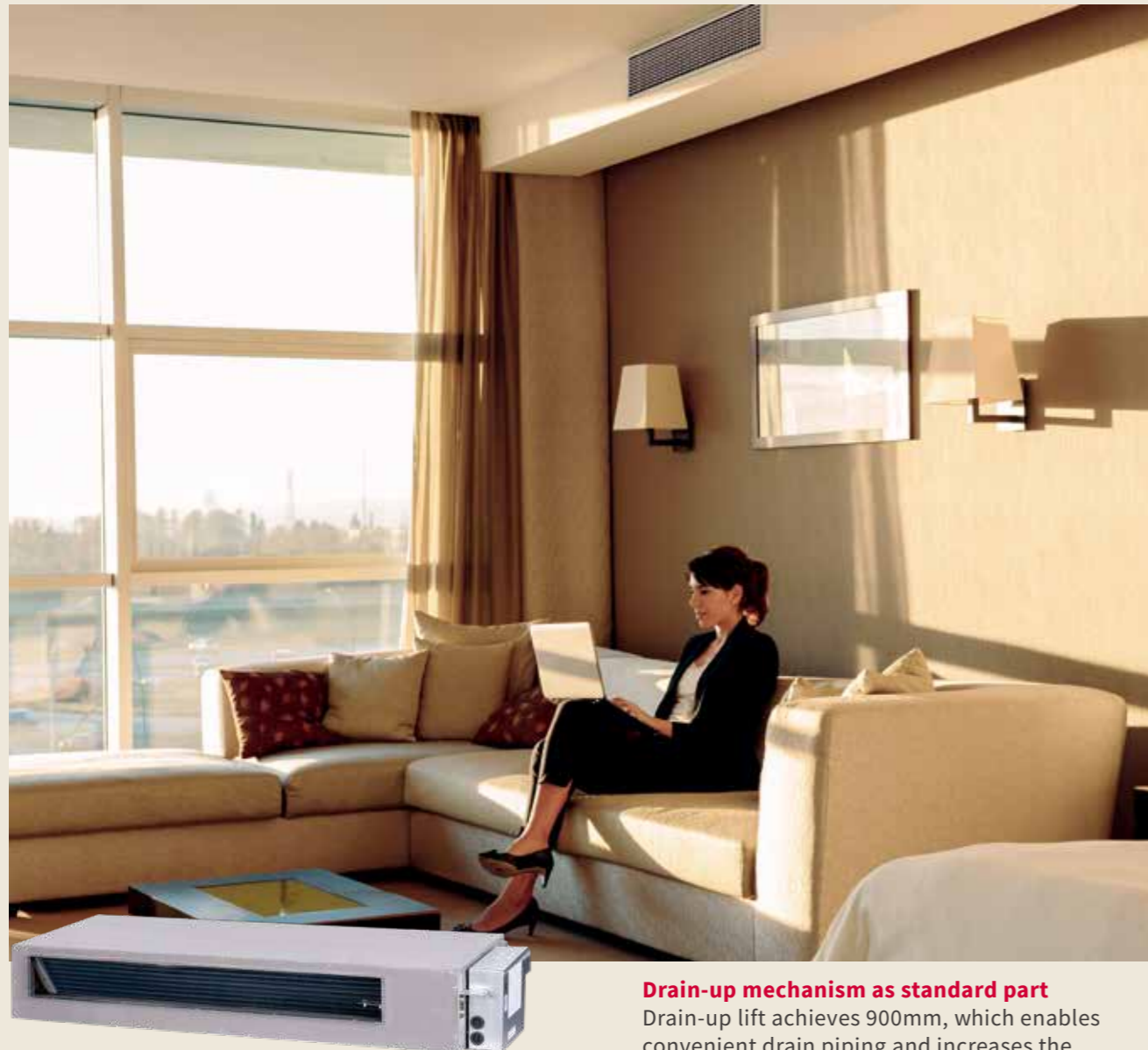

Drain-up mechanism as standard part
 Drain-up lift achieves 900mm, which enables convenient drain piping and increases the flexibility of installation.

Space saving installation

192mm in height, low height residential ceilings pose no problem in installation. Low width starting of 700mm makes this model suitable for installation in limited spaces in hotels.

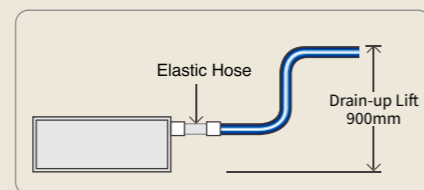
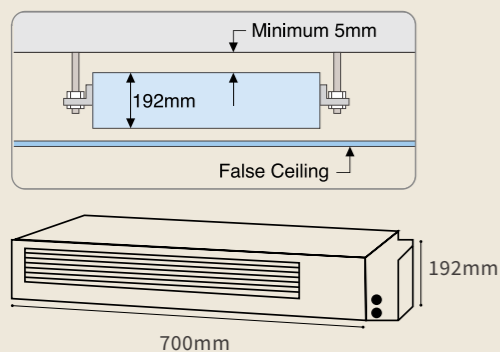

Designed for customised installations

The air inlet is available as rear or bottom entry, which gives the consumers the option to choose relevant air inlet mode according to the practical installation space.

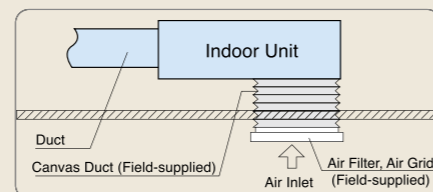

(Installation Diagram of Air Bottom Inlet)

*For 1 HP model

In-the-ceiling (Duct type)



Broad range of external static pressure
 At 20-50 Pa, installation options comes in both long duct and short duct variants.

Connect multiple rooms
 Flexibility to connect multiple rooms with single IDU when there is lesser space available.

Flexibility in installation
 Flexible installation with both LHS and RHS installation provisions. Suitable for any mirror application installation in hotels, villas, etc. (available in 1.0, 1.5, & 2.0 HP models)

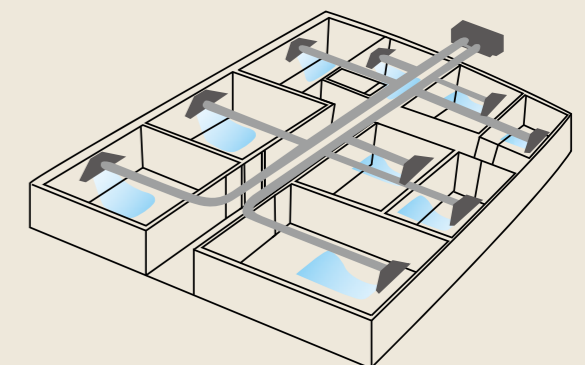

Floor concealed

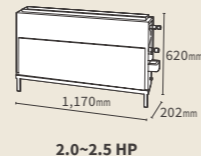
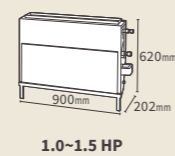

Design flexibility

- Blends unobtrusively with any interior décor, only the suction and discharge grilles are visible
- Its low height (only 620mm) enables the unit to fit perfectly beneath a window
- Requires little installation space thanks to its slim 202mm depth

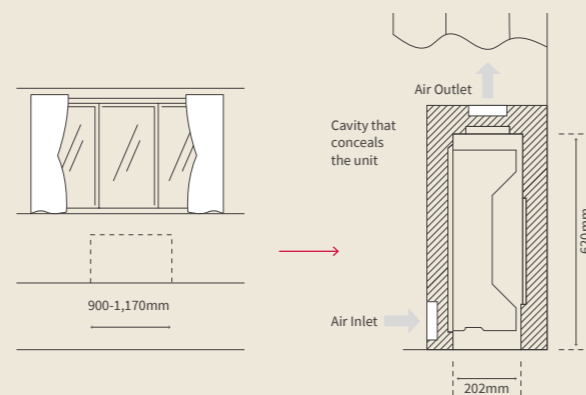

Floor/Ceiling convertible

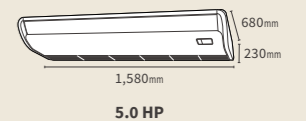
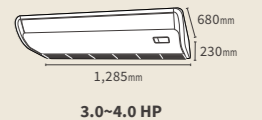
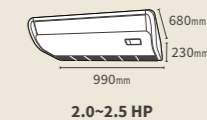

Installation on floor or ceiling

- When performance and practicality are a priority, convertible units are a functional solution
- Suitable for creating a calming and comfortable atmosphere in small to medium-sized spaces
- Each unit can be floor mounted or ceiling suspended
- Installation is simple and straight forward

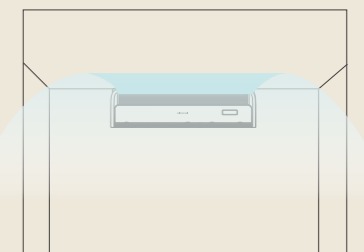
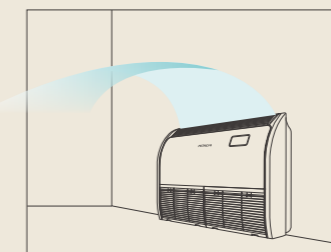

Hi wall

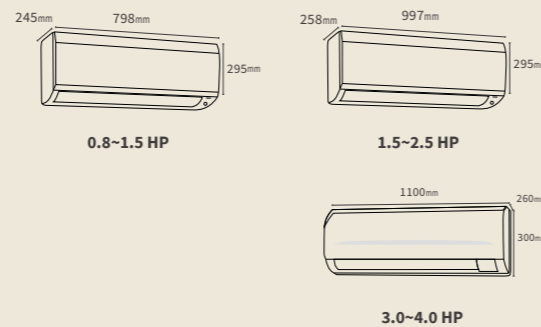

iClean+ technology

The revolutionary Auto Filter Cleaning technology in Hitachi Air Conditioners cleans the stainless steel coated filter of the AC automatically every 12 hours of cumulative running. The auto cleaning brush moves twice over the dust catcher to increase dust transfer capacity and ensures filter becomes dust free. Thus, the air coming from the AC is always clean and fresh.

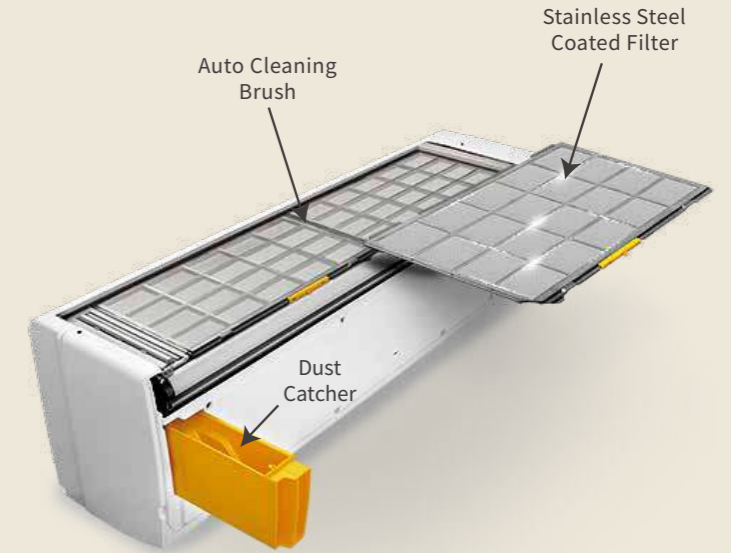

Benefits

Ever efficient

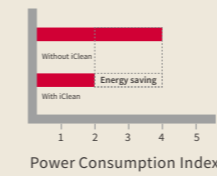

Ever powerful

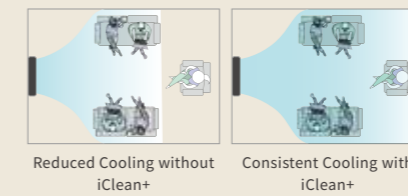

Ever clean

Dust on filter after a few days

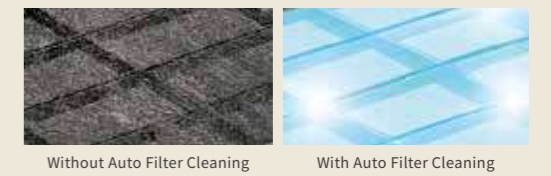

*Available in Hi-Wall iClean+ unit only

Motion Sensor technology

Motion Sensor technology comes with the ability to ensure you get equal attention for equal cooling comfort and enjoy higher energy savings. It identifies the number of people and directs airflow as per the requirement. In case of human absence, the sensor automatically switches the AC off, reducing wastage of energy. Motion Sensor technology is available in RPK-FSNK1/2

Motion Sensor Technology to achieve better energy saving

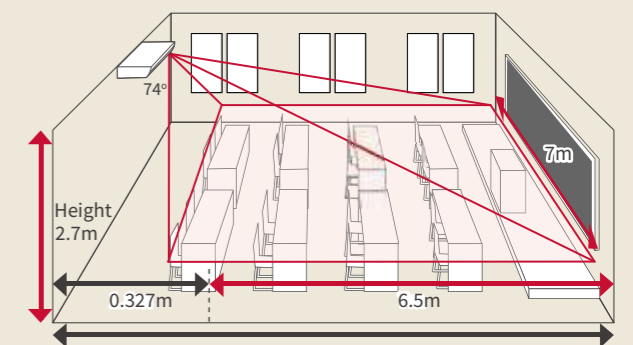

Specifications

4 way cassette

Model		RCI-1.0FSKDN1Q	RCI-1.5FSKDN1Q	RCI-2.0FSKDN1Q	RCI-2.5FSKDN1Q	RCI-3.0FSKDN1Q	RCI-4.0FSKDN1Q	RCI-5.0FSKDN1Q	RCI-6.0FSKDN1Q	
Indoor Unit Power Supply		AC 1Φ, 220-240 V / 50 Hz								
Nominal Cooling Capacity*1	KW	2.8	4.0	5.6	7.1	8.0	11.2	14.0	16.0	
Nominal Heating Capacity*2	KW	3.2	4.8	6.3	8.5	9.0	12.5	16.0	18.0	
Sound Pressure Level*3 (Hi2/Hi/Me/Lo)	dB(A)	33/30/28/27	35/31/30/27	37/32/30/27	42/36/32/28	42/36/32/28	48/43/39/33	48/45/40/35	48/46/41/37	
Outer Dimensions	Height	mm	238	238	238	238	288	288	288	
	Width	mm	840	840	840	840	840	840	840	
	Depth	mm	840	840	840	840	840	840	840	
Net Weight	kg	20	21	21	22	26	26	26	26	
Refrigerant		R410A								
Indoor Fan	Air Flow Rate (Hi2/Hi/Me/Lo)	m ³ /min.	15/13/11/9	21/17/14/11	22/17/14/11	27/23/18/14	27/23/18/14	37/31/24/20	37/33/26/21	37/35/28/22
		cfm	530/459/388/318	741/600/494/388	777/600/494/388	953/812/635/494	953/812/635/494	1306/1095/847/706	1306/1165/918/741	1306/1235/989/777
Motor Output	W	57	57	57	57	57	127	127	127	
Connections		Flare-Nut Connection (with Flare Nuts)								
Refrigerant Piping	Liquid Line	mm	Φ6.35	Φ6.35	Φ6.35	Φ9.52	Φ9.52	Φ9.52	Φ9.52	Φ9.52
	Gas Line	mm	Φ12.7	Φ12.7	Φ12.7	Φ15.88	Φ15.88	Φ15.88	Φ15.88	Φ15.88
	Condensate Drain		VP25							
Decoration Panel		Included								
Color		Neutral White								
Outer Dimensions (H X W X D)	mm	40 X 950 X 950								

1 way cassette

Model		RCIS-1.0FSKDNQ	RCIS-1.3FSKDNQ	RCIS-1.6FSKDNQ	RCIS-2.0FSKDNQ	RCIS-2.5FSKDNQ	
Indoor Unit Power Supply		AC 1Φ, 220-240 V / 50 Hz					
Nominal Cooling Capacity*1	KW	2.8	3.6	4.5	5.6	7.1	
Nominal Heating Capacity*2	KW	3.2	4.0	5.0	6.3	8.0	
Sound Pressure Level*3 (Hi2/Hi/Me/Lo/Slo/Silent)	dB (A)	32/31/30/29/28/27	37/35/34/32/30/28	41/37/34/33/31/30	40/38/35/33/32/31	46/42/40/37/34/32	
Outer Dimensions	Height	mm	192	192	192	192	
	Width	mm	910	910	910	1180	
	Depth	mm	470	470	470	470	
Net Weight	Kg	19	20	20	24	24	
Refrigerant		R410A					
Indoor Fan	Air Flow Rate (Hi2/Hi/Me/Lo/Slo/Silent)	m ³ /min	6.6/6.2/5.6/5.1/4.8/4.6	8.3/7.3/6.8/6.2/5.6/5.1	10/8.3/6.8/6.3/5.7/5.2	12.1/9.9/8.8/8.2/7.8/6.6	15.6/12.6/11.2/9.9/8.4/7.1
		cfm	233/219/198/180/169/162	293/258/240/219/198/180	353/293/240/222/201/183	427/350/311/290/275/233	551/445/395/350/297/251
Connections		Flare-Nut Connection (with Flare Nuts)					
Refrigerant Piping	Liquid Line	mm	Φ6.35	Φ6.35	Φ6.35	Φ9.53	
	Gas Line	mm	Φ12.7	Φ12.7	Φ12.7	Φ15.88	
	Condensate Drain		VP25				
Decoration Panel		P-N45SNKQAE		P-N71SNKQAE			
Color		Neutral White			Neutral White		
Outer Dimensions (H X W X D)	mm	55 X 1100 X 550			55 X 1370 X 550		
Net Weight	Kg	5.0			6.0		

Notes for RCI-FSKDNQ, RCIM-FSN4, RCIS-FSKDNQ & RCD-FSR:
 *1 & *2. The cooling and heating capacities shown in the table are based on following conditions:
 Cooling Operation Conditions: Indoor Air Inlet Temperature: 27° C DB, 19° C WB. Outdoor Air Inlet Temperature: 35° C DB.
 Heating Operation Conditions: Indoor Air Inlet Temperature: 20° C DB. Outdoor Air Inlet Temperature: 7° C DB , 6° C WB.
 Piping Length: 7.5 meters. Piping Lift: 0 meter.

4 way compact cassette

Model		RCIM-1.0FSRE	RCIM-1.5FSRE	RCIM-2.0FSRE	RCIM-2.5FSRE
Indoor Unit Power Supply		AC 1Φ, 220-240 V / 50 Hz			
Nominal Cooling Capacity*1	KW	2.8	4.0	5.6	7.1
Nominal Heating Capacity*2	KW	3.2	4.8	6.3	8.5
Sound Pressure Level*3 (Hi2/Hi/Me/Lo)	dB(A)	38/34/30/24.5	41/37/33/27.5	45/39/35/31	47/43/39/35
Outer Dimensions	Height	mm	285	285	285
	Width	mm	570	570	570
	Depth	mm	570	570	570
Net Weight	kg	16	16	17	17
Refrigerant		R410A			
Indoor Fan	Air Flow Rate (Hi2/Hi/Me/Lo)	m ³ /min.	12/10/8.5/6	13/11/9.5/7	15/12/10/8
		cfm	424/353/300/212	459/388/335/247	530/424/353/282
Motor Output	W	57	57	57	57
Connections		Flare-Nut Connection (with Flare Nuts)			
Refrigerant Piping	Liquid Line	mm	Φ6.35	Φ6.35	Φ9.52
	Gas Line	mm	Φ12.7	Φ12.7	Φ15.88
	Condensate Drain		VP25		
Decoration Panel		P-AP56NAM (without motion sensor)			
Color		Neutral White			
Outer Dimensions (H X W X D)	mm	30 X 620 X 620			
Net Weight	kg	2.5			

2 way cassette

Model		RCD-0.8FSR	RCD-1.0FSR	RCD-1.5FSR	RCD-2.0FSR	RCD-2.5FSR	RCD-3.0FSR	RCD-4.0FSR	RCD-5.0FSR	RCD-6.0FSR	
Indoor Unit Power Supply		AC 1Φ, 220-240 V / 50 Hz									
Nominal Cooling Capacity*1	KW	2.2	2.8	4.0	5.6	7.1	8.0	11.2	14.0	16.0	
Nominal Heating Capacity*2	KW	2.5	3.2	4.8	6.3	8.5	9.0	12.5	16.0	18.0	
Sound Pressure Level*3 (Hi2/Hi/Me/Lo)	dB(A)	30/29/28/27	31/29/28/27	37/34/31/30	39/36/33/30	42/39/36/33	45/42/38/33	43/40/37/34	47/44/41/35	48/45/42/39	
Outer Dimensions	Height	mm	298	298	298	298	298	298	298	298	
	Width	mm	860	860	860	860	860	1,420	1,420	1,420	
	Depth	mm	630	630	630	630	630	630	630	630	
Net Weight	kg	23	23	25	25	25	25	39	39	39	
Refrigerant		R410A									
Indoor Fan	Air Flow Rate (Hi2/Hi/Me/Lo)	m ³ /min.	10/9/7.5/6.5	11/9.5/8.5/7	15/13/11.5/10	16.5/14.5/12.5/10.5	18.5/16.5/14.5/12.5	21/18.5/16/12.5	30/26.5/23/20	35/31/27/21	37/32.5/28.5/24
		cfm	353/318/265/230	388/335/300/247	530/459/406/353	583/512/441/371	653/583/512/441	742/653/565/441	1,059/936/812/706	1,236/1,095/953/742	1,306/1,147/1,006/847
Motor	W	57	57	57	57	57	57	57 x 2	57 x 2	57 x 2	
Connections		Flare-Nut Connection (with Flare Nuts)									
Refrigerant Piping	Liquid Line	mm	Φ6.35	Φ6.35	Φ6.35	Φ6.35	Φ9.52	Φ9.52	Φ9.52	Φ9.52	
	Gas Line	mm	Φ12.7	Φ12.7	Φ12.7	Φ12.7	Φ15.88	Φ15.88	Φ15.88	Φ15.88	
	Condensate Drain		VP25								
Decoration Panel		P-AP90DNA (for RCD- [0.8-3.0] FSR)				P-AP160DNA (for RCD- [4.0-6.0] FSR)					
Color		Neutral White				Neutral White					
Outer Dimensions (H X W X D)	mm	30 X 1100 X 710				30 X 1660 X 710					
Net Weight	kg	7.5				10.5					

Notes for RCI-FSKDNQ, RCIM-FSN4, RCIS-FSKDNQ & RCD-FSR:
 *3. The sound pressure level is based on following conditions:
 1.5 meters beneath the unit. The data's mentioned in table was measured in an anechoic chamber so that reflected sound should be taken into consideration in the field.

Floor/Ceiling convertible

Model		RPFC-2.0FSNQ	RPFC-2.5FSNQ	RPFC-3.0FSNQ	RPFC-4.0FSNQ	RPFC-5.0FSNQ
Indoor Unit Power Supply		AC 1Φ, 220-240 V / 50 Hz				
Nominal Cooling Capacity*1	KW	5.6	7.1	8.4	11.2	14.2
Nominal Heating Capacity*2	KW	6.5	8.5	9.6	13.0	16.3
Sound Pressure Level*4 (Hi/Me/Lo)	Ceiling	39/35/30	45/41/37	43/39/34	51/46/40	50/46/42
	Floor	43/38/35	48/44/40	46/41/37	54/49/43	55/50/46
Outer Dimensions	Height	mm 230	230	230	230	230
	Width	mm 990	990	1,285	1,285	1,580
	Depth	mm 680	680	680	680	680
Net Weight	kg	31	32	39	41	47
Refrigerant		R410A				
Indoor Fan	Air Flow Rate (Hi/Me/Lo)	m ³ /min 13/11/9	16.1/14/11.3	18.2/15.2/12.2	24.8/20.5/16.3	33/28/23
		cfm 459/388/318	568/494/399	643/537/431	876/724/576	1165/989/812
Motor Output	W	40	70	70	130	160
Connections		Flare-Nut Connection (with Flare Nuts)				
Refrigerant Piping	Liquid Line	mm Φ6.35	Φ9.53	Φ9.53	Φ9.53	Φ9.53
	Gas Line	mm Φ15.88	Φ15.88	Φ15.88	Φ15.88	Φ15.88
	Condensate Drain	VP25				

Hi wall

Model		RPK-0.8FSNK2	RPK-1.0FSNK2	RPK-1.3FSNK2	RPK-1.5FSNK2	RPK-2.0FSNK2	RPK-2.5FSNK2	RPK-1.5FSNK1	RPK-2.0FSNK1	RPK-2.5FSNK1	RPK-3.0FSRM	RPK-4.0FSRM
Indoor Unit Power Supply		AC 1Φ, 230 V / 50 Hz										
Nominal Cooling Capacity*1	KW	2.2	2.8	3.6	4.0	5.6	7.1	4.0	5.6	7.1	8.0	11.2
Nominal Heating Capacity*2	KW	2.6	3.2	4.2	4.8	6.3	8.5	4.8	6.3	8.5	9.0	12.5
Sound Pressure Level*3 (Hi2/Hi/Me/Lo/Slo)	dB (A)	40/38/36/34/32	43/40/37/35/33	45/40/37/35/33	45/40/37/35/33	48/45/42/39/35	49/46/43/40/36	45/42/39/37/35	48/45/42/39/35	49/46/43/40/36	47/44/40/35	51/48/44/39
	Height	mm 295	295	295	295	295	295	295	295	295	300	300
Outer Dimensions	Width	mm 798	798	798	798	997	997	997	997	997	1100	1100
	Depth	mm 245	245	245	245	258	258	258	258	258	260	260
Net Weight	Kg	10.0	10.0	10.0	10.0	13.5	13.5	13.5	13.5	13.5	15.0	15.0
Refrigerant		R410A										
Indoor Fan	Air Flow Rate (Hi2/Hi/Me/Lo/Slo)	m ³ /min 9.8/9.1/8.5/7.8/7.1	10.5/9.8/8.5/8.0/7.3	12/10.7/9.3/8.8/8	12/10.7/9.3/8.8/8	16.6/15/13.5/11.5/10	19/17.2/15.4/13.1/11.4	15/13.5/11.5/10.7/10	16.6/15/13.5/11.5/10	19/17.2/15.4/13.1/11.4	20/17.5/15.5/12.5	23/20/17.5/14.5
		cfm 346/321/300/275/250	371/346/300/282/258	424/378/328/311/282	424/378/328/311/282	586/530/477/406/353	671/607/544/462/403	530/477/406/378/353	586/530/477/406/353	671/607/544/462/403	706/618/547/441	812/706/618/512
Motor Output	W	18	18	18	18	30	30	30	30	30	38	38
Connections		Flare-Nut Connection (with Flare Nuts)										
Refrigerant Piping	Liquid Line	mm Φ6.35	Φ6.35	Φ6.35	Φ6.35	Φ6.35	Φ9.52	Φ6.35	Φ6.35	Φ9.52	Φ9.52	Φ9.52
	Gas Line	mm Φ12.7	Φ12.7	Φ12.7	Φ12.7	Φ15.88	Φ15.88	Φ12.7	Φ15.88	Φ15.88	Φ15.88	Φ15.88
iClean Function		No	No	No	No	No	No	Yes	Yes	Yes	No	No

Notes for RPFC-FSNQ, RPIZ-HNATN1Q, RPK-FSNK2/FSNK1/FSRM & RPIL-FSNK/FSNK3:
 *1 *1 & *2. The cooling and heating capacities shown in the table are based on following conditions:
 Cooling Operation Conditions: Indoor Air Inlet Temperature: 27° C DB, 19° C WB. Outdoor Air Inlet Temperature: 35° C DB.
 Heating Operation Conditions: Indoor Air Inlet Temperature: 20° C DB. Outdoor Air Inlet Temperature: 7° C DB, 6° C WB.
 Piping Length: 7.5 meters. Piping Lift: 0 meter.

In-the-ceiling

Model		RPIZ-1.0HNATN1Q	RPIZ-1.5HNATN1Q	RPIZ-2.0HNATN1Q	RPIZ-2.5HNATN1Q
Indoor Unit Power Supply		AC 1Φ, 220-240V / 50 Hz			
Nominal Cooling Capacity*1	KW	2.8	4.0	5.6	7.1
Nominal Heating Capacity*2	KW	3.2	4.5	6.3	8.0
Sound Pressure Level*3 *5 (Hi/Me/Lo)		30/23/20	32.5/26/23	34/26/25	37/29/27
	Height	mm 192	192	192	192
Outer Dimensions	Width	mm 700	910	1180	1180
	Depth	mm 447	447	447	447
Net Weight	Kg	17.0	20.0	25.0	25.0
Refrigerant		R410A			
Indoor Fan	Air Flow Rate (Hi/Me/Lo)	m ³ /min 9.5/6.5/5.5	10/7/6	15/10/9	17/10/9
		cfm 335/230/194	353/247/212	530/353/318	600/353/318
External Static Pressure*6	Pa	10(30)	10(30)	10(30)	10(30)
Motor Output	W	28	28	45	60
Connections		Flare-Nut Connection (with Flare Nuts)			
Refrigerant Piping	Liquid Line	mm Φ6.35	Φ6.35	Φ6.35	Φ9.53
	Gas Line	mm Φ12.7	Φ12.7	Φ15.88	Φ15.88

In-the-ceiling

Model*7		RPIL1.0FSNK3/K4	RPIL1.5FSNK3/K4	RPIL2.0FSNK3/K4	RPIL2.0FSNK	RPIL2.5FSNK	RPIL3.0FSNK	RPIM4.0FSNK	RPIM5.0FSNK	RPIM6.0FSNK
Indoor Unit Power Supply		AC 1Φ, 230 V / 50 Hz								
Nominal Cooling Capacity*1	KW	2.8	4.3	5.6	5.6	7.1	8.4	11.2	14.0	16.0
Nominal Heating Capacity*2	KW	3.3	4.9	6.3	6.3	8.5	9.0	12.5	16.0	18.0
Sound Pressure Level*3 *5 (Hi/Me/Lo)	dB (A)	32/30/28	36/34/32	37/35/33	36/34/31	37/34/32	40/37/33	52/49/47	55/52/50	57/54/52
	Height	mm 280	280	280	280	280	280	385	385	385
Outer Dimensions	Width	mm 800	800	800	1130	1130	1130	1190	1190	1190
	Depth	mm 535	535	535	535	535	535	675	675	675
Net Weight	Kg	28.0	28.0	28.0	31.0	32.0	32.0	63.0	65.0	67.0
Refrigerant		R410A								
Indoor Fan	Air Flow Rate (Hi/Me/Lo)	m ³ /min 10/8/7	13/11/9	15/13/11	18.4/15.7/14	23/20/15.6	28/24/20	33/31/28	45/41/37.5	56/52/48
		cfm 353/282/247	459/388/317	529/459/388	650/550/500	800/700/550	1000/850/700	1200/1100/990	1600/1460/1325	1977/1836/1695
External Static Pressure	Pa	19	19	19	19	19	19	49	49	60
Motor Output	W	24	24	24	50	50	50	220	220	630
Connections		Flare-Nut Connection (with Flare Nuts)								
Refrigerant Piping	Liquid Line	mm Φ6.35	Φ6.35	Φ6.35	Φ6.35	Φ9.52	Φ9.52	Φ9.52	Φ9.52	Φ9.52
	Gas Line	mm Φ12.7	Φ12.7	Φ15.88	Φ15.88	Φ15.88	Φ15.88	Φ15.88	Φ15.88	Φ15.88

Notes for RPFC-FSNQ, RPIZ-HNATN1Q, RPK-FSNK2/FSNK1/FSN4M & RPIL-FSNK/FSNK3:
 The sound pressure level is based on following conditions:
 *3. 1.5 meters beneath the unit. *4. 1 meter from the unit & 1 meter from the floor level.
 The data mentioned in the table was measured in an anechoic chamber so that reflected sound should be taken into consideration in the field.
 *5 When bottom air inlet is adopted, sound pressure will increase according to factors such as installation mode & the room structure.
 *6 The data for external pressure indicates standard pressure setting values when air filter is not used. Suction filter is not included as standard supply.
 *7. More Models RPIL1.0FSNK4, RPIL1.5FSNK4, RPIL2.0FSNK4 are available with left hand side installation provision.

In-the-ceiling (Duct type - High static)

MODEL		RPI8.0FSNK1	RPI10FSNK1	RPI12FSNK	RPI16FSNK	RPI20FSNK	RPI16FSNK1	RPI20FSNK1	
Indoor Unit Power Supply		AC 1Φ, 230V / 50 HZ				AC 3Φ, 415V / 50 HZ			
Nominal Cooling Capacity	KW	22.4	28.0	33.5	45.0	56.0	45.0	56.0	
Nominal Heating Capacity	KW	25.0	31.5	37.5	50.0	63.0	50.0	63.0	
Sound Pressure Level (Hi/Me/Lo)	dB (A)	62/59/57	64/61/59	65/62/60	66/63/60	68/65/62	68.0	72.0	
Outer Dimensions	Height	mm	440	440	440	550	550	1550(V)/725(H)	
	Width	mm	1550	1550	1550	2040	2040	1550(V)/1550(H)	
	Depth	mm	675	675	675	1085	1085	800(V)/1615(H)	
Net Weight	Kg	81.0	81.0	83.0	191.0	194.0	250.0	253.0	
Refrigerant		R410A							
Indoor Fan	Air Flow Rate (Hi/Me/Lo)	m³/min	85/77.6/70	96/87.5/80	105/96/88	150/142/135	170/162/154	166	186
		cfm	3000/2740/2480	3400/3100/2810	3700/3390/3100	5300/5010/4760	6000/5720/5440	5860	6560
External Static Pressure	Pa	78	78	78	100	100	150	150	
Motor Output	W	630	630	900	550 (3)	550 (3)	3000	3000	
Connections		BRAZING CONNECTION							
Refrigerant Piping	Liquid Line	mm	Φ 9.52	Φ 9.52	Φ 12.7	Φ 12.7	Φ 15.88	Φ 12.7	Φ 15.88
	Gas Line	mm	Φ 19.05	Φ 22.22	Φ 25.4	Φ 28.58	Φ 28.58	Φ 28.58	Φ 28.58

Floor concealed

Model		RPFI-1.0FSNQ	RPFI-1.5FSNQ	RPFI-2.0FSNQ	RPFI-2.5FSNQ	
Indoor Unit Power Supply		AC 1Φ, 230 V / 50 Hz				
Nominal Cooling Capacity*1	KW	2.8	4.3	5.6	7.1	
Nominal Heating Capacity*2	KW	3.3	4.9	6.5	8.5	
Sound Pressure Level*3 (Hi/ Me/ Lo)	dB (A)	37/34/31	40/38/35	42/38/36	45/43/40	
Outer Dimensions	Height	mm	620	620	620	
	Width	mm	900	900	1170	
	Depth	mm	202	202	202	
Net Weight	Kg	25	26	34	34	
Refrigerant		R410A				
Indoor Fan	Air Flow Rate Hi/Me/Lo	m³/min	8.0/7.0/6.0	10/8.0/7.0	14.5/12.5/10.5	16/14/12
		cfm	282/247/212	353/282/247	512/441/371	565/494/424
Motor Output	W	20	35	40	50	
Connection		Flare-Nut Connection (with Flare Nuts)				
Refrigerant Piping	Liquid Line	mm	Φ6.35	Φ6.35	Φ6.35	Φ9.53
	Gas Line	mm	Φ12.7	Φ12.7	Φ15.88	Φ15.88
	Condensate Drain		VP 25	VP 25	VP 25	VP 25

Notes for RPFI-FSNQ:

***1 & *2. The cooling and heating capacities shown in the table are based on following conditions:**

Cooling Operation Conditions: Indoor Air Inlet Temperature: 27° C DB, 19° C WB. Outdoor Air Inlet Temperature: 35° C DB.

Heating Operation Conditions: Indoor Air Inlet Temperature: 20° C DB. Outdoor Air Inlet Temperature: 7° C DB, 6° C WB.

Piping Length: 7.5 meters. Piping Lift: 0 meter.

***3. The sound pressure level is based on following conditions:**

1.5 meters from the unit and 1.5 meters from floor level. The data's mentioned in the table was measured in an anechoic chamber so that reflected sound should be taken into consideration in the field.

Silent-Iconic™

Model		RCI-1.0FSRP	RCI-1.5FSRP	RCI-2.0FSRP	RCI-2.5FSRP	RCI-3.0FSRP	RCI-4.0FSRP	RCI-5.0FSRP	RCI-6.0FSRP	
Indoor Unit Power Supply		AC 1Φ, 220-240V / 50 Hz								
Nominal Cooling Capacity	KW	2.8	4.0	5.6	7.1	8.0	11.2	14.0	16.0	
Nominal Heating Capacity	KW	3.2	4.8	6.3	8.5	9.0	12.5	16.0	18.0	
Sound Pressure Level (Hi2/Hi/Me/Lo)	dB (A)	33/30/28/27	35/31/30/27	37/32/30/28	43/37/33/29	41/36/32/30	49/44/39/33	49/46/41/35	49/47/43/37	
Outer Dimensions	Height	mm	248	248	248	248	298	298	298	
	Width	mm	840	840	840	840	840	840	840	
	Depth	mm	840	840	840	840	840	840	840	
Net Weight	Kg	20	21	21	22	26	26	26	26	
Refrigerant		R410A								
Indoor Fan	Air Flow Rate (Hi2/Hi/Me/Lo)	m³/min	15/13/11/9	20/16/14/11	22/17/14/12	27/21/18/14	27/23/18/15	36/31/24/20	37/33/26/21	37/35/28/22
		cfm	530/459/388/318	706/565/494/388	777/600/494/424	953/741/635/494	953/812/635/529	1271/1095/847/706	1306/1165/918/741	1306/1235/989/777
Refrigerant Piping	Liquid Line	mm	Φ6.35	Φ6.35	Φ6.35	Φ9.52	Φ9.52	Φ9.52	Φ9.52	
	Gas Line	mm	Φ12.7	Φ12.7	Φ12.7	Φ15.88	Φ15.88	Φ15.88	Φ15.88	
	Condensate Drain	mm	VP25							
Cassette Air Panel (Silent Iconic Type)		P-GP160NAPU (Optional Item)								
Panel Dimensions (H X W X D)	mm	52 x 950 x 950								
Panel Net Weight	Kg	10								
Compatible Wired Remote Controller		PC-ARFG2-A (Optional Item)								

Notes for RCI-FSRP:

The above cooling and heating capacities show the maximum capacities when the outdoor and indoor temperatures are below condition.

Cooling Operation Conditions:

Indoor Air Inlet Temperature: 27° C DB 19° C WB, Outdoor Air Inlet temperature 35° C DB

Heating Operation Conditions:

Indoor Air Inlet Temperature: 20° C DB, Outdoor Air Inlet temperature: 7° C DB 6° C WB

Pipe length: 7.5 meters; Pipe lift: 0 meter

The sound pressure level is based on following conditions

1.5 Meters Beneath the Unit. The above data was measured in an anechoic chamber so that the reflected sound should be taken into consideration in the field

* Wireless remote is not compatible..



Ventilation

Improve indoor air quality

Today, the average person spends more than 75% of their day indoors. Without proper ventilation, CO2 levels rise, pollutants circulate and potentially harmful bacteria build-up, impacting on the wellbeing, comfort and productivity of occupants. Make these spaces as healthy and comfortable as possible by connecting our ventilation solutions into your Hitachi VRF systems.

81 OUR VENTILATION LINE-UP

83 VENTILATION SOLUTIONS

83 All fresh air unit

84 Total heat exchanger

85 DX-KIT



Our ventilation line-up

Our line-up fulfils the ventilation requirements of the desired space by drawing in clean air from the outside and replenishing indoor spaces. It features solutions that suit every type of building; you can use the ventilation technology as it is or it can be incorporated into a Hitachi indoor unit via the fresh-air port. Thanks to our ventilation options, you can optimize the design of your system to meet your needs.

ALL FRESH AIR UNIT



- Creates a comfortable and healthy indoor environment, thanks to the fresh air and heat/cool functions.
- Various controllers can be selected and interfaced with the H-LINK system.
- Longer ducts can be connected on-site, thanks to the higher ESP.

TOTAL HEAT EXCHANGER



- Creates a healthy indoor environment thanks to the fresh air and ventilation functions.
- Every unit is equipped with a remote controller for the total heat exchanger as a standard part.

From 120 to 6,000m³/h

Fan Air Flow Rate (m ³ /h)	120	170	180	250	300	500	750	1000	1080	1250	1500	1680	2000	2100	2500	3000	4000	5000	6000
All Fresh Air Unit									•			•		•		•	•	•	•
Total Heat Exchanger	•	•	•	•	•	•	•	•					•						•

Extra air-renewal solution offerings

We offer two additional options to meet both occupants' needs and your building's requirements.



DX-KIT

- Offers great flexibility by enabling you to integrate Hitachi VRF into your building's existing air handling units (AHU).
- Wide capacity range (available up to 112 HP AHU).
- Wide configuration options with AHU/Indoor units.

FRESH-AIR INTAKE PORT



- Optional duct adapter which enables fresh air into the unit so that it can be blown out with conditioned air.
- Connects with the indoor units: 4-way cassette type, 4-way compact cassette type, 2-way cassette type, 1-way cassette type.



Ventilation solutions



All fresh air unit

Model	RPI-5.0KFNQ		RPI-8.0KFNQ		RPI-10.0KFNQ		RPI-12.0KFNQ	
Power Supply	AC 1Φ 220-240V/ 50Hz	AC 1Φ 220V/ 60Hz	AC 1Φ 220-240V/ 50Hz	AC 1Φ 220V/ 60Hz	AC 1Φ 220-240V/ 50Hz	AC 1Φ 220V/ 60Hz	AC 3Φ 380-415V/ 50Hz	AC 3Φ 380V/ 60Hz
Connectable Outdoor Unit	Slim Modular VRF SideSmart™ (Heat Pump Type)						RAS-120HNCEL(/R)W	
Cooling	Capacity	kW	14.0	14.0	22.4	22.4	28.0	28.0
	Power	kW	0.30	0.35	0.48	0.55	0.50	0.58
	Nominal Current	A	1.4	1.61	2.2	2.53	2.3	2.65
Heating	Capacity	kW	13.7	13.7	21.9	21.9	24.5	24.5
	Power	kW	0.30	0.35	0.48	0.55	0.50	0.58
	Nominal Current	A	1.4	1.61	2.2	2.53	2.3	2.65
Sound Pressure Level (overall a scale)	dB(A)	42	42	44	44	47	47	56
Dimensions H×W×D	mm	370×1320×800		486×1270×1069		486×1270×1069		486×1270×1069
Net Weight	kg	63	63	110	110	110	110	110
Refrigerant		R410A	R410A	R410A	R410A	R410A	R410A	R410A
Air Flow Rate	m ³ /min	18	18	28	28	35	35	50
External Pressure	Pa	200	200	220	220	220	220	220
Piping	Liquid	mm	Φ9.53	Φ9.53	Φ9.53	Φ9.53	Φ9.53	Φ12.7
	Gas	mm	Φ15.88	Φ15.88	Φ19.05	Φ19.05	Φ22.2	Φ22.2
Condensate Drain		VP25, Outer Diameter: Φ32mm						
Temperature range of fresh air drawn		Cooling: 20.0°C~43.0°C, Heating: -7.0°C~15.0°C						

Model	RPI-16.0KFNQL		RPI-16.0KFNQH		RPI-20.0KFNQL		RPI-20.0KFNQH		RPI-20.0KFNQLF		RPI-20.0KFNQHF	
Power Supply	AC 3Φ 380-415V/ 50Hz	AC 3Φ 380V/ 60Hz	AC 3Φ 380-415V/ 50Hz	AC 3Φ 380V/ 60Hz	AC 3Φ 380-415V/ 50Hz	AC 3Φ 380V/ 60Hz	AC 3Φ 380-415V/ 50Hz	AC 3Φ 380V/ 60Hz	AC 3Φ 380-415V/ 50Hz	AC 3Φ 380V/ 60Hz	AC 3Φ 380-415V/ 50Hz	AC 3Φ 380V/ 60Hz
Connectable Outdoor Unit	RAS-160HNCEL(/R)W				RAS-200HNCEL(R)WS, RAS-200HNCEL(R)WP, RAS-200HNCEL(R)WS							
Cooling	Capacity	kW	45.0	45.0	45.0	45.0	56.0	56.0	56.0	56.0	56.0	56.0
	Power	kW	0.72	0.83	1.06	1.22	1.06	1.22	1.39	1.6	1.39	1.60
	Nominal Current	A	1.8	2.07	2.2	2.53	2.22	2.55	3.14	3.61	3.0	3.45
Heating	Capacity	kW	36.0	36.0	36.0	36.0	44.8	44.8	44.8	44.8	44.8	44.8
	Power	kW	0.72	0.83	1.06	1.22	1.06	1.22	1.39	1.6	1.39	1.60
	Nominal Current	A	1.8	2.07	2.2	2.53	2.22	2.55	3.14	3.61	3.0	3.45
Sound Pressure Level (overall a scale)	dB(A)	58	58	62	62	61	61	65	65	63	63	67
Dimensions H×W×D	mm	635×1950×805		635×1950×805		735×1950×805		735×1950×805		735×1950×805		735×1950×805
Net Weight	kg	196	196	196	196	222	222	222	222	222	222	222
Refrigerant		R410A	R410A	R410A	R410A	R410A	R410A	R410A	R410A	R410A	R410A	R410A
Air Flow Rate	m ³ /min	67	67	67	67	83	83	83	83	100	100	100
External Pressure	Pa	200	200	300	300	200	200	300	300	200	200	300
Piping	Liquid	mm	Φ12.7	Φ12.7	Φ12.7	Φ12.7	Φ15.88	Φ15.88	Φ15.88	Φ15.88	Φ15.88	Φ15.88
	Gas	mm	Φ25.4	Φ25.4	Φ25.4	Φ25.4	Φ28.6	Φ28.6	Φ28.6	Φ28.6	Φ28.6	Φ28.6
Condensate Drain		RC1 (Internal Screw)										
Temperature range of fresh air drawn		Cooling: 20.0°C~43.0°C, Heating: -7.0°C~15.0°C										

- Notes:
- Cooling capacity and heating capacity tested in the following conditions:
Cooling conditions: 33.0°CDB, 28.0°CWB, pipeline length 7.5 metre, pipe height difference 0 metre.
Heating conditions: 0°CDB, -2.9°CWB, pipeline length 7.5 metre, pipe height difference 0 metre (heating is the data without defrosting).
 - Noise test conditions are as follows:
At a distance of 1.5 metre from the unit surface.
The above parameters are measured in the anechoic chamber without reflected echo, therefore the impact of the reflected echo must be counted at the scene.
 - An air filter with dust removal efficiency of 50% or more needs to be installed at the air inlet.
 - When the field duct resistance is small and the fan speed is too high, the unit will appear the phenomena of abnormal shutdown, fault, water spray etc., and the duct pipe should be insulated to prevent generating dew.
 - Air processor can only be used for processing fresh air, indoor air conditioning load processing need to use other air conditioners.
 - Fresh air processing unit should be connected with Slim Modular VRF SideSmart™, Heat Pump Type, outdoor unit.
When fresh air processing unit and other indoor units air all connected to the same SideSmart™ outdoor unit, its equivalent cooling capacity is calculated by the following criteria:
Type_5HP class: 21.0kW; 8HP class: 33.3kW; 10HP class: 42.0kW.
 - Refer to capacity restrains shown on Table below for indoor unit capacity connectable to outdoor unit.

System	All Fresh Air Unit System (Only All Fresh Air Unit)	Mixed System (All Fresh Air Unit and Other Indoor Unit)
Range of Combination Capacity	80 to 100%	i) 80 to 100% and ii) Total Capacity of All Fresh Air: 30%

- Mixed system is only available with RPI-5.0/8.0/10.0KFNQ.
RPI-12.0KFNQ or above is only available as one to one All Fresh Air Unit system.
- When outdoor temperature is below 20.0°C in cooling operation, the system will be automatically converted to ventilation operation.
When outdoor temperature is higher than 15.0°C in heating operation, it will be automatically converted to ventilation operation. When lower than -7.0°C, the fresh air processing unit will stop running.

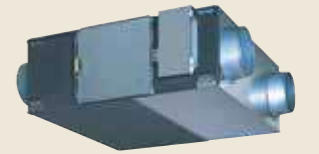

Total heat exchanger

Model	Unit	KPI-25H-A-GQ1	KPI-50H-A-GQ1	KPI-100H-A-GQ1	KPI-200H-A-GQ1	KPI-500H-A-GQ1
Unit Power Supply		220V-50Hz	220V-50Hz	220V-50Hz	380V/3N/50Hz	380V/3N/50Hz
Enthalpy exchange efficiency-Cooling (Hi/Me/Lo)	%	63/63/70	63/63/65	57/57/58	56/-/-	56/-/-
Enthalpy exchange efficiency-Heating(Hi/Me/Lo)	%	70/70/75	69/69/71	66/66/68	65/-/-	65/-/-
Operating noise(Full anechoic Chamber) (Hi/Me/Lo)	dB	32.5/28.5/23.5	38.5/33.5/26.5	43/41/38	47/-/-	56/-/-
Outer Dimension (LxWxH)	mm	962/735/220	1112/735/270	1115/1135/390	1550/1400/540	1550/1400/540
Net Weight	Kg	42	52	71.5	153.5	242
Gros Weight	Kg	50	61	92	186.5	288
Air Flow Rate (Hi/Me/Lo)	m ³ /h	250/170/120	500/300/180	1000/750/500	2000/-/-	5000/-/-
External Static Pressure(Hi/Me/Lo)	Pa	80/50/30	80/70/40	165/120/60	160/-/-	240/-/-
Power Input (Hi/Me/Lo)	W	162/106/76	313/204/140	1020/900/726	1550/-/-	1550/-/-
Current (Hi/Me/Lo)	A	0.75/0.48/0.35	1.42/0.95/0.67	4.88/4.3/3.47	2.59/-/-	2.59/-/-
Flange Dimension	mm	Ø144	Ø194	Ø242	"320 x 300 320 x 300"	"320 x 300 320 x 300"

Note:
Please confirm the model name for "wires remote controller" compatible with Total Heat Exchanger to your local distributor.



DX-Kit

Integrate Hitachi VRF into your pre-existing Air Handling Units (AHU).

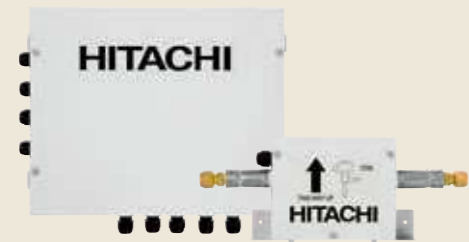

Dimensions

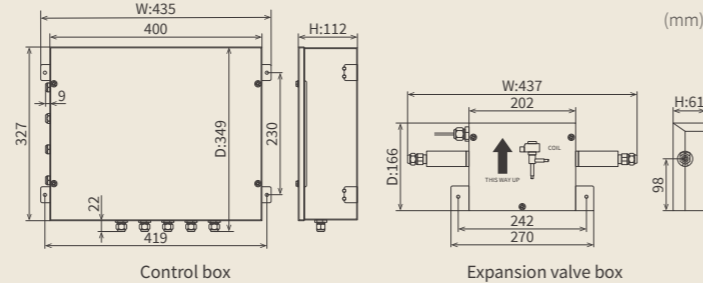

Capacity (HP)	2	4	6	8/10	12~20	22~30
Model	DXF-2.0A1	DXF-4.0A1	DXF-6.0A1	DXF-10.0A1	DXF-20.0A1	DXF-30.0A1
Power Supply	AC1Φ, [220-240V /50Hz] [220V 60Hz]					
Control Box (C Box)	Height	112	112	112	112	112
	Width	435	435	435	435	435
	Depth	349	349	349	349	349
	Weight	5.2	5.2	5.2	5.2	5.2
	Material	Steel Plate + White Grey Coating				
Expansion Valve Box (EXV Box)	Height	61	61	61	61	61
	Width	437	437	437	437	437
	Depth	166	166	166	166	166
	Weight	1.7	1.7	1.7	1.7	1.7
	Quantity	1	1	1	1	2
AHU Suction Temperature Range	Cooling	21.0°C to 32.0°C (DB) / 15.0°C to 23.0°C (WB)				
	Heating	15.0°C to 27.0°C (DB)				

Connection Ratio in different configurations
 → Total AHU or AHU & IDU Connection Ratio against ODU capacity = X
 (In case of "Inlet Air Temperature Control")

- 1 ODU to 1 AHU : 50% $X \le 100\%$
- 1 ODU to 1 AHU (Separate Heat Exchanger Type) : 50% $X \le 100\%$
- 1 ODU to Multiple AHUs : 50% $X \le 100\%$
- 1 ODU to AHU & IDUs : 1 ODU to AHU & IDUs :

Maximum Piping Length	Total	m						
	Between AHU Heat Exchanger and EXV Box	m	5	5	5	5	5	5
Maximum Level Difference	Between ODU and [AHU/IDU]	m	• 50 (When ODU is above [AHU & IDU & DX-Kit].) • 40 (When ODU is below [AHU & IDU & DX-Kit].)					
	Between AHU Heat Exchanger and EXV Box	m	2	2	2	2	2	2
Maximum Length	Control wiring between AHU Heat Exchanger and EXV Box	m	10	10	10	10	10	10
	Thermistor to AHU Heat Exchanger from C Box	m	10	10	10	10	10	10

Temperature Control Modes (*1)
 • Inlet Air Temperature Control
 • Outlet Air Temperature Control
 • Duty Control

(*1) [Outlet Air Temperature Control] & [Duty Control] are available only in case of connections "1 ODU to 1 AHU" & "1 ODU to 1 AHU (Separate Heat Exchanger Type)".

DX-KIT: Great flexibility for simplified HVAC upgrade

① Wide range of capacity:

- (DX-Kit) Single capacity from 2HP to 30HP
- (Custom AHU) up to 112 HP available by DX-Kit combination

Our DX-Kit can cover from small to large capacity AHU. It can meet any requirement in any application!

② Flexible installation:

- Both outdoor & indoor installation of DX-Kit available
- Design Flexibility in wiring & piping

DX-Kit facilitates system design!

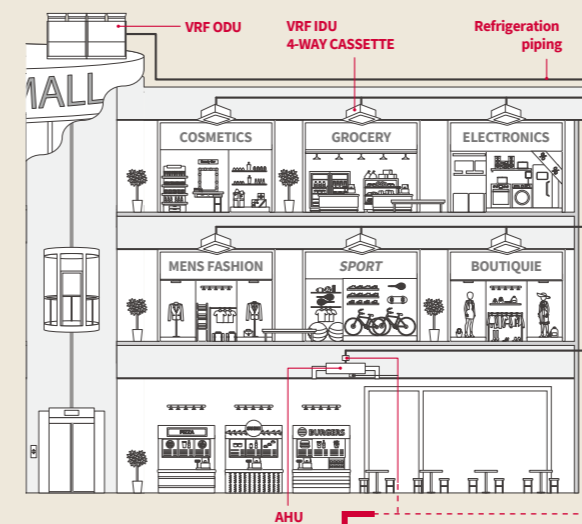

DX-Kit Above : Expansion Valve Box (EXV Box). Below : Control Box (C Box).

Both outdoor & indoor installations available!

Item	Max (m)
Level difference between AHU Heat Exchanger and EXV Box	H1 2
Piping length between AHU Heat Exchanger and EXV Box	L1 5
Length of control wiring between AHU Heat Exchanger and EXV Box	L2 10
Length of the thermistor to AHU Heat Exchanger from C Box	L3 10

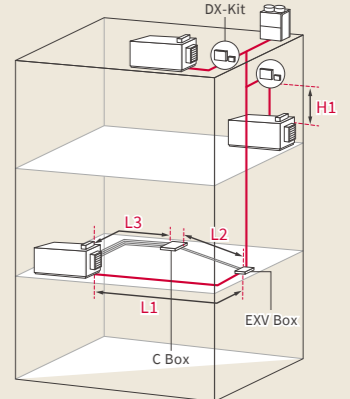

③ 4 examples of configuration:

- 1 VRF outdoor unit + 1 AHU
- 1 VRF outdoor unit + 1 AHU (external heat exchanger)
- 1 VRF Outdoor unit + multiple AHUs
- 1 VRF Outdoor unit + VRF indoor units + AHUs

[Example]

DX-Kit
 Left: Control Box (C Box)
 Right: Expansion Valve Box (EXV Box)

Various available AHU capacity connections.

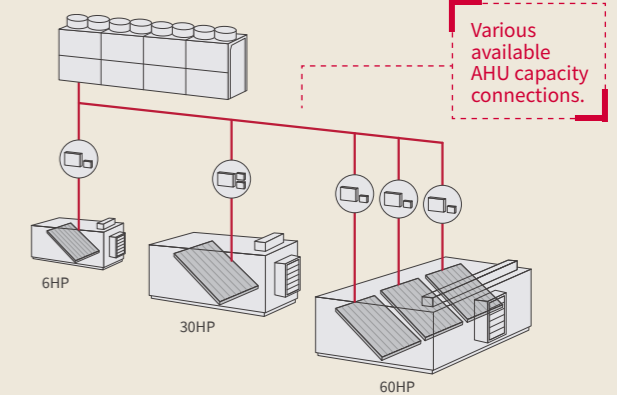

Up to 5 heat exchangers can be connected via DX-Kit!

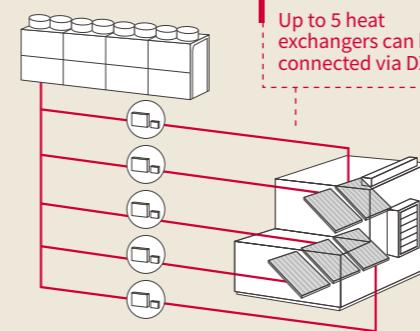

Flexible combination with VRF indoor units.

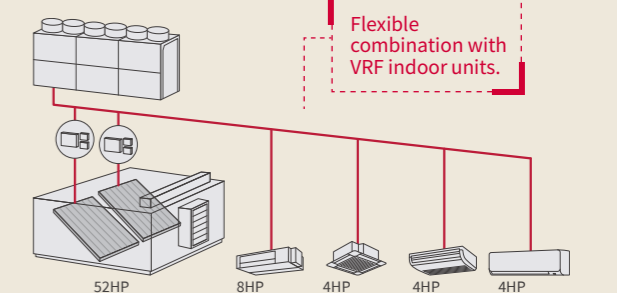

Controllers



New generation: simple and smart!

Everyone deserves comfort, but comfort does not mean the same to everyone. That's why control is key.

Our controllers offer best-in-class simplicity. Using our praised central stations, building managers can instantly optimize air conditioning in targeted zones.

For occupants, our new advanced color controller provides intuitive navigation with a premium design.

With airCloud Pro, our exclusive new-generation solution, users can manage from one indoor unit to several systems remotely via IoT (web/smartphone).

89 CENTRALIZED CONTROLLERS

90 Line up overview

91 **airCloud** Pro

93 Central Station EX

94 Central Station EZ

94 Central Station mini

95 INDIVIDUAL CONTROLLERS

96 Line up overview

97 Advanced color wired remote controller

100 Eco-Compact controller

101 Wired remote controller

101 Advanced wireless remote controller

102 Wireless remote controller

102 Receiver kit

103 H-LINK: ENJOY MORE FREEDOM

Centralized controllers

Control each indoor unit, one specific zone or even multiple systems from one place!

airCloud Pro* (HC-IoTGW)

- Remote access via smartphone app or web
- Unlimited number of systems, zones and users
- Intuitive scheduling function
- Troubleshooting with access to error history and alerts
- Filter sign display to quickly overview daily maintenance needs
- Ideal for all types of applications

Central station EX (PSC-A128EX3)

- Control capacity: max 2,560 indoor units (+15x Extension Adapter (PSC-AD128EX3))
- With energy calculation software (PSC-AS01EXC), determine each tenant's energy usage
- Easy monitoring with simplified interface
- Best option for middle-large size buildings
- Remote access! Operate Central Station EX from your laptop PC or touch-panel PC

Central station EZ (PSC-A64GT)

- Control capacity: max 64 remote control group of indoor units
- Compact and optimized 170x250mm body screens fitting in even small walls
- Easy monitoring with simplified interface
- Best option for middle size buildings

Central station mini (PSC-A32MN)

- Control capacity: max 32 remote control group of indoor units
- Compact and optimized 120x140mm body screens fitting in even small walls
- Easy monitoring with simplified interface
- Best option for small size buildings

*airCloud Pro available with SideSmart™ from May 2021.

Small to large systems & fixed or cloud-based

		airCLOUD PRO	CENTRAL STATION MINI	CENTRAL STATION EZ	CENTRAL STATION EX
		HC-IoTGW	PSC-A32MN	PSC-A64GT	PSC-A128EX3
Capacity comparison	RC group	64 (*6)	32	64	2,560 (*1)
	Group	64 (*6)	32	64	2,048 (*1)
	Block	Unlimited (*7)	2/4/8/16	4	512 (*2)
	Area	Unlimited (*7)	-	-	512 (*2)
	Indoor unit	80 (*6)	160	160	2,560 (*1)
	Outdoor unit	16 (*6)	64	64	1,024 (*1)
Building scale		Small to Large	Small	Medium	Large
Operation		Web + Mobile Phone	Touch screen	Touch screen	Touch screen + Web (New!)
Operation panel size options		Adaptive	3	2	7
Display	Layout	-	-	-	●
	List options	-	-	-	3
	All together	●	●	●	●
Operation unit	By layout	-	-	-	●
	By area	●	-	-	●
	By block	●	●	●	●
Control Function	By group	●	-	-	●
	By RC group	-	●	●	-
	By indoor unit	●	-	-	●
Monitor Function	Main 5 functions (*5)	●	●	●	●
	Individual controller lock	●	●	Δ (*3)	●
	Filter sign reset	●	●	●	●
	Outdoor unit capacity control	-	Δ (*4)	-	●
	Outdoor unit noise control	-	-	-	●
	Main 5 functions (*5)	●	●	●	●
	Individual controller lock	●	●	●	●
	Alarm status & code	●	●	●	●
	Filter sign	●	●	●	●
	Air inlet temperature of indoor unit	-	●	-	●
Air inlet temperature of outdoor unit	-	●	-	●	
Schedule Function	Weekly	●	●	●	●
	Setting times per day	16	10	10	16
	Special day setting	5	-	-	5
	Holiday setting	-	-	-	●
	Annual/Summer/Winter schedule	Future Version	-	-	●
Other function	Alarm history (records number)	Unlimited	100	100	10,000
	External in/output history	-	-	-	1,000
	Management report visualization(*11)	-	●	●	●
IoT Functions	Data output by external media	Download from Web - Future	-	-	SD card, USB flash device
	Connectivity	Ethernet + 4G (*9)	-	-	-
	Future Extendability	Firmware OTA (*10) Web + Mobile Update	-	-	-

* airCloud Pro available with SideSmart™ from May 2021.

(*1) One Extension Adapter (PSC-AD128EX3) enable CENTRAL STATION EX to control additional 160 RC groups / 128 groups / 160 IDUs / 64 ODU, and up to 15 adapters can connect to one Central Station EX.

(*2) No restriction on the number of H-LINK.

(*3) Individual Feature Control in Each Remote Controller is not available.

(*4) Applicable only with Schedule function or external signal input. You cannot set it up directly from monitoring panel.

(*5) Main 5 functions meaning: 1) Run/Stop 2) Operation mode 3) Temperature setting 4) Fan speed 5) Louver control.

(*6) Ability to connect unlimited number of "HC-IoTGW" in one project and control all AC units via one single screen on Web or Mobile Phone.

(*7) Unlimited creation of zones, across multiple "HC-IoTGW" units within the same project.

(*8) Visualization of outdoor unit energy consumption.

(*9) 4G available through optional 4G module; 4G module package comes with global SIM and pre-paid global data plan.

(*10) OTA: Over-the-air firmware update, provides always up-to-date firmware and latest functionalities.

(*11) Mini, EZ: Accumulated operation time (min), Accumulated thermo - ON (min).

EX: Accumulated operation time (min), Accumulated thermo - ON time (min), Average air intake temperature of indoor unit, Average air intake temperature of outdoor unit, Average setting temperature, Average RC sensor temperature.

Centralized controllers

airCloud Pro*

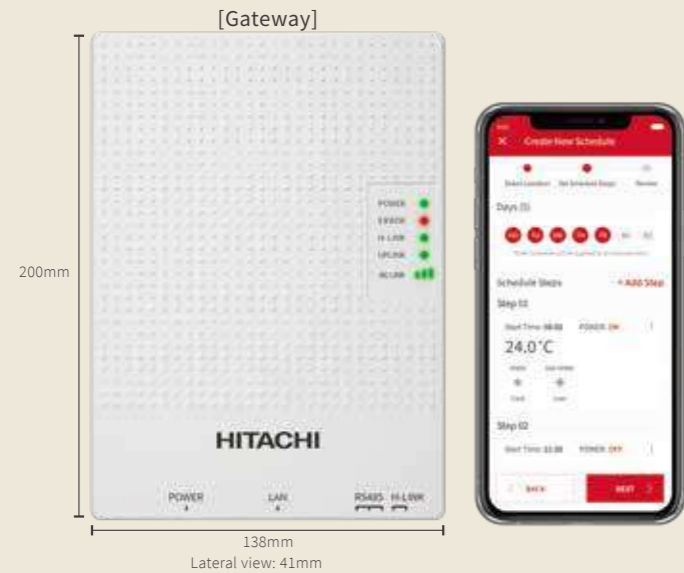

Specifications

Gateway	HC-IoTGW
Net weight (g)	540
Connection capacity	16 outdoor + 80 indoor units
Power supply (V) (Hz)	100-240, AC 50/60
Max. power consumption (W)	10
Communication port	1 H-LINK, 1 RS485 Port
Internet connection	LAN (Ethernet) or 4G ³
External interface (log storage)	1 micro SD card slot

Functions

IoT connection (cloud-based)	<ul style="list-style-type: none"> • Access via smartphone app or web • Unlimited number of gateways • Unlimited number of locations • Unlimited number of users 	<ul style="list-style-type: none"> • On/Off • Mode • Set temperature • Air intake temperature • RC sensor temperature (*3) • Air intake temperature of outdoor unit • Fan Speed • Louver • RC prohibition • Thermo-ON information • Filter sign/Auto cleaning fault • Alarm status/Alarm codes
Operation unit	<ul style="list-style-type: none"> • Per entire location • Per system • Per zone (unlimited zone creation) • Per indoor unit remote control group 	<ul style="list-style-type: none"> • Weekly schedule • Easy selection of days and zones • Setting items in schedule is as below; • On/Off • Operation mode • Setting temperature • Louver • Fan speed
Control function	<ul style="list-style-type: none"> • On/Off • Mode • Set temperature • Fan speed • Louver • RC lock • Filter sign reset 	

*"All Groups Run/Stop" command signal exception function for selected groups is available by "Exception of Run/Stop Operation." function.

System configuration.



Recommended facilities (examples.)



Is airCloud Pro for me?

All VRF users can enjoy these benefits!

- Save energy
- Save time and unnecessary transportation
- Delegate VRF systems administration
- Create a comfortable climate for guests

Future-proof

With updates and new features added regularly, airCloud Pro ensures you are always up to date.



- Compatible with new and former
- Hitachi Variable Refrigerant
- Flow systems*1

Control is in your hands.
24/7 control at your fingertips on smartphone, tablet, or PC.



✓ Intuitive simplicity

airCloud Pro is designed to make your job easier. An intuitive app that anyone can use, airCloud Pro makes managing your VRF systems easier than ever before.

✓ Control from anywhere

Enjoy the freedom of remote access from your smartphone, tablet or laptop. airCloud Pro allows you to remotely control your VRF system(s) from a single app, saving you travel time.

A simple yet powerful tool.

👍 Simplify your job

The pilot app makes managing your VRF systems easy.

- **Centralized control**
Control your entire VRF system or selected zones in one touch.
- **Simplified troubleshooting**
A clear error history, concise error description and follow-up.
- **Smartphone alerts²**
In the event of a critical malfunction.
- **Flexible user management²**
Add users and custom access restrictions.

🌍 Save more energy

Plan and optimize the usage.

- **Intuitive scheduling**
Plan operations ahead based on your business hours.
- **Individual controller lock**
Prevent inappropriate usage from occupants.

❤️ Create better comfort

Adjust temperature, fan speed, and modes with ease, creating total comfort and the ideal climate throughout your building.

An integrated weather forecast^{*2} display helps you determine the most suitable conditions for your indoor spaces all year round.

✂️ Easy plug-and-play

Our airCloud gateway makes installation a breeze.

Connect to the airCloud via 3G/4G^{*3} or ethernet and pair your VRF systems via QR code scan. With automatic detection of indoor units and an optimized installer view, configuring your site and zones has never been quicker.



+ data security

Best-in-class standards:
TLS.v1.2, HTTPS 2038 encryption.

Minimal personal details:
Only your name, email address and phone number are required for login.

*airCloud Pro available with SideSmart™ from May 2021.

*1 Confirm compatibility of your VRF installation with your Hitachi Cooling & Heating representative.

*2 Functions not available as of September 2019, coming soon.

*3 4G module available as a side accessory.

Centralized controllers

Central station EX

for large-scale buildings (PSC-A128EX3)



For middle or large-scale buildings such as hotels, educational facilities, and hospitals, our Central Station EX features a highly intuitive and functional 12.1-inch wide, wall-mountable, color LCD screen.

Control up to 2,560 indoor units with our proprietary H-LINK system with 15 extension adapters (PSC-AD128EX3).

Also, with energy calculation software (PSC-AS01EXC), Central Station EX can help you easily manage each tenant's electricity & report the power consumption of VRF system for each tenant.

Install by add-on software and activate, then, you can select electricity ratio or usage ratio from several methods.

Capacity

H-LINK	16
RC group	2,560 (*1)
Group	2,048 (*1)
Block	512 (*2)
Area	512 (*2)
Indoor unit	2,560 (*1)
Outdoor unit	1,024 (*1)
Building scale	Large

Extension adapter



PSC-AD128EX3

(*1) 1 extension adapter (PSC-AD128EX3) enables Central Station EX to control additional 160 RC groups / 128 groups / 160 IDUs / 64 ODUs. Central Station EX can connect up to 15 adapters
(*2) No restriction on the number of H-LINK

Energy calculation software*



PSC-AS01EXC

Specifications

Rated power supply	100~240VAC ±10% (50/60Hz)
Electrical power consumption	50W (Max.)
Communication unit	Units of Adopting for H-LINK
Communication line	Two-wire non-polar
Communication speed	9,600bps
Wiring length	1,000m (Total Length)
Display	12.1-inch TFT color liquid crystal display
Display control	Touch Panel

Functions

Operation unit	All together Each area Each block Each group Each indoor unit	Schedule function	Each of the following settings is available in 3 different [annual] [summer][winter] categories: → Weekly schedule → Up to 16 actions can be set per day → Exception day setting: 5 different types → Holiday setting	Energy saving: • Run/Stop • RC prohibition • Temperature shift (For Cool/Dry mode: +1.0°C~+9.0°C (+1.0°F~+18.0°F)) (For Heat mode: -1.0°C~-9.0°C (-1.0°F~-18.0°F)) • Mode shift (Mode shifted to Fan when in Cool/Dry mode, and shifted to Stop in Heat mode) • Capacity control on outdoor units • Lower noise control for outdoor units
Control function	On/Off Mode Set temperature Fan speed Louver RC prohibition Filter sign reset Function selection for indoor units (*1) Function selection for outdoor units (*2) Capacity control for outdoor units (*2) Lower noise control for outdoor units (*2)	History	Setting items in schedule is as below: • On/Off • Operation mode • Setting temperature • Louver • Fan speed • RC operation prohibition • Capacity control for outdoor units • Lower noise control for outdoor units	External input / output Control/Monitor → Controlled items: • Run/Stop • Mode (Cool/Heat) → Monitored items: • Run/Stop • Mode (Cool/Heat) • Alarm state
Monitor function	On/Off Mode Set temperature Air intake temperature RC sensor temperature (*3) Air intake temperature of outdoor unit Fan Speed Louver RC prohibition Thermo-ON information Filter sign/Auto cleaning fault Alarm status/Alarm codes	Management report visualization	Alarm history: 10,000 records External In/Output history: 1,000 records Pulse input history: 6 months	Others: • Power consumption signal input • Emergency stop

(*1) Some indoor units may not fully support all functions.
(*2) Available for applicable outdoor units only.
(*3) Whether this is shown on the screen depends on the remote controller settings.

Central station EZ

for medium-scale buildings (PSC-A64GT)



With easy control via an 8.5-inch color touch panel, its detailed control functionalities such as Weekly Scheduling, Operation hours tracking, and more, help you save energy. Up to 64 remote-controlled groups and up to 160 indoor units can be connected to the Central Station EZ.

Capacity

RC group	64
Group	64
Block	4
Indoor Unit	160
Outdoor Unit	64
Building Scale	Small-Medium

Specifications

Rated Power Supply	1-, AC 100-240V, 50/60Hz
Electrical Power Consumption	30W (Max.)
Communication Unit	Units of Adopting for H-LINK
Communication Line	Non-polar 2-wire
Communication Speed	9,600bps
Wiring Length	1,000m (Total Length)
Display	8.5-inch Wide Color LCD (Full Dot)
Display Control	Touch Panel

Functions

Monitor Function	• Run/Stop/Abnormality • Setting Temperature • RC Operation Prohibited Setting • Accumulated Operating Time • Operation Mode • Setting Fan Speed • Setting Louver • Filter Sign • Alarm Code
Control Function	• Run/Stop* • Fan Speed • Operation Mode • Louver • Temperature Setting • RC Operation Prohibited • Filter Sign Reset

*The "All Groups Run/Stop" command signal exception function for selected groups is available via the "Exception of Run/Stop Operation" function.

Central station mini

for small-scale buildings (PSC-A32MN)

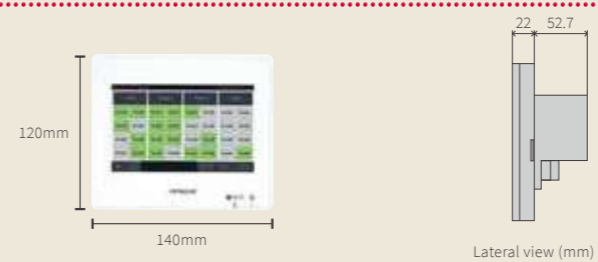

With easy control via an 5.0-inch color touch panel, its detailed control functionalities such as weekly scheduling, operation hours tracking, help you save energy. Up to 32 remote-controlled groups and up to 160 indoor units can be connected to the Central Station mini.

Capacity

RC group	32
Group	32
Block	4 Patterns (2/4/8/16)
Indoor Unit	160
Outdoor Unit	64
Building Scale	Small

Specifications

Rated Power Supply	1-, AC 100-240V, 50/60Hz
Electrical Power Consumption	20W (Max.)
Communication Unit	Units of Adopting for H-LINK
Communication Line	Non-polar 2-wire
Communication Speed	9,600bps
Wiring Length	1,000m (Total Length)
Display	5.0-inch Wide Color LCD (Full Dot)
Display Control	Touch Panel

Functions

Monitor Function	• Run/Stop/Abnormality • Setting Temperature • RC Operation Prohibited Setting • Accumulated Operating Time • Operation Mode • Setting Fan Speed • Setting Louver • Filter Sign • Alarm Code"
Control Function	• Run/Stop* • Fan Speed • Operation Mode • Louver • Temperature Setting • RC Operation Prohibited • Filter Reset Signal

*"All Groups Run/Stop" command signal exception function for selected groups is available by "Exception of Run/Stop Operation." function.

Remote access.

You can now operate Central Station EX from your laptop PC or touch panel PC. Install our software and you can connect from anywhere, using our VPN network.

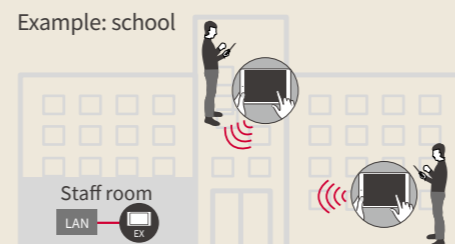

Individual controllers



NEW Advanced color wired remote controller (PC-ARFG2-A)

- Exclusive color screen & Award-winning design.
- Simplified menu and enhanced UI/UX
- Includes latest VRF features such as FrostWash™ and several comfort settings (with selected IDU and ODU models)

Wired remote controller (HCWA10NEGQ)

- 88mm square controller with LCD screen
- Smaller body with multiple features
- Best option for spaces frequented by recurring users, e.g. offices

Advanced wireless remote controller (PC-AWR)

- Wireless remote controller with more features
- Several temperature units and settings available; 0.5°C/1.0°C/1.0°F
- Ideal for controlling the unit from anywhere in the room, e.g. residential spaces

NEW Eco-Compact Model (PC-ARC-A)

- Support Near Field Communications(NFC) contact-less-enabled system commissioning via airCloud Tap smartphone app
- Embedded IR Receiver(for selected wireless remote)
- User friendly segment UI design

Wireless remote controller (PC-LH7QE2)

- Budget option featuring primary control settings.
- 1.0°C temperature step
- Ideal for visitors to control the unit from anywhere in the room, e.g. hotel suite

From basic to advanced controls

		NEW PC-ARFG2-A	NEW PC-ARC-A	HCWA10NEGQ	PC-AWR	PC-LH7QE2
Connection Capacity	No of RC-Group No of indoor units	1 16	1 16	1 16	- -	- -
Product Size	Width*Height*Depth (mm)	120*120*16.5 (D: thinnest part)	90*90*15.5 (D: thinnest part)	88*88*15.5	140*55*16.8	140*52*19.3
Screen		Color LCD with backlight	Segment LCD with backlight	Segment LCD with backlight	Segment LCD	Segment LCD
Embedded IR receiver		-	●	-	-	-
Smartphone App	Use With Aircloud Tap	● (support NFC)	● (support NFC)	-	-	-
Essential Operations	Run / Stop	●	●	●	●	●
	Operation Mode	●	●	●	●	●
	Auto Mode Setting	●	●	●	●	●
	Temperature Setting	●	●	●	●	●
	Fan Speed	●	●	●	●	●
	Louver Direction	●	●	●	●	●
	Simple Timer	●	● (On/Off Timer)	● (On/Off Timer)	● (On/Off Timer)	● (On/Off Timer)
	Weekly Operation Schedule	●	-	-	-	-
	Power Savings Setting	●	● (Capacity Control only)	-	-	-
	Night Quiet Operation	●	-	-	-	-
Advanced Feature Settings	Power Savings/Night Quiet Schedule	●	-	-	-	-
	Power Consumption Display	●	-	-	-	-
	AutoBoost	●	●	-	-	-
	Comfort Setting	●	● (GentleCool only)	-	-	-
	Sleep Mode	-	●	-	-	-
	Motion Sensor Setting (1)	●	-	-	-	-
	Setback Setting	●	-	-	-	-
	Elevating Grille	●	-	-	-	-
	Filter Reminder Time Reset	●	●	●	●	●
	Filter Auto-Cleaning (1)	●	-	-	-	-
Display Settings	FrostWash Setting (1)	●	-	-	-	-
	Individual Louver Setting	●	●	●	-	-
	Louver Open/Close	●	-	-	-	-
	Ventilation	●	-	-	-	-
	Total Heat Exchanger SET	●	-	-	-	-
	Adjusting Date/Time	●	●	●	-	-
	Daylight Saving Time	●	-	-	-	-
	Run Indicator Brightness Adjustment	●	● (Only On/Off setting)	-	-	-
	Display Adjustment	●	-	-	-	-
	Temperature Units (°C/°F)	●	●	●	●	- (°C only)
Temperature setting at 0.5°C step	●	●	●	●	- (1.0°C only)	
Room Temperature Display	●	●	●	-	-	
Language available	EN, JPN, CN (traditional & simplified), FR, ES, PT	EN	EN	EN	EN	
Service Functions	Keypad Touch Sound	●	●	● (Cannot turn off)	-	-
	Lock Function	●	● (Lock function individually)	● (Lock whole keypad)	-	-
	Password Setting	●	-	-	-	-
	Hotel Mode	●	-	-	-	-
	Power Saving Details Setting	●	-	-	-	-
	Temperature Range Restriction	●	● (in Function Selection)	● (in Function Selection)	-	-
	Dual Setpoint	●	-	-	-	-
	Main/Sub Display	●	-	-	-	-
	Set Room Name	●	-	-	-	-
	Set Contact Information	●	-	-	-	-
Installation Functions	NFC Setting	●	●	-	-	-
	Simple Maintenance Check Menu	●	-	-	-	-
	Test Run	●	●	●	-	-
	Function Selection	●	●	●	-	-
	Thermistor Selection	●	● (in Function Selection)	● (in Function Selection)	-	-
	Input/Output	●	●	●	-	-
	Thermistor Calibration in Controller	●	● (in Function Selection)	-	-	-
	Fan Speed At Thermo-Off	●	● (in Function Selection)	● (in Function Selection)	-	-
	Indoor Unit Address Change	●	●	●	-	-
	Address Check Operation	●	-	-	-	-
Check Menu	Address Initialization	●	-	-	-	-
	Setting Initialization	●	-	-	-	-
	Main/Sub Controller Setting	●	●	●	-	-
	Priority Setting	●	-	-	-	-
	Cancel Preheating Control	●	-	-	-	-
	Elevating Grille Setting	●	-	-	-	-
	Power Up Setting	●	-	-	-	-
	Setback Trigger Unit	●	-	-	-	-
	Refrigerant Leak Sensor Setting	●	-	-	-	-
	Check 1	●	●	●	-	-
Other features	Check 2	●	●	●	-	-
	Alarm History Display	●	●	●	-	-
	Display Model Number	●	-	-	-	-
	Check PCB of the Units	●	-	-	-	-
	Self Check	●	●	●	-	-
Other features	Synchronize Date/ time with Central Controller	● (Only available from Central Station EX PSC-A128EX3)	● (Only available from Central Station EX PSC-A128EX3)	-	-	-
	Stop operation delay	●	●	-	-	-
	Emergency operation	●	●	-	-	-
	Two WRC Control	●	●	-	-	-
	Alarm Display	●	●	●	-	-
Filter cleaning reminder sign display	●	●	●	-	-	

(*1) Available when the controller is connected with selected indoor unit offering this feature.

Individual controllers

NEW
Advanced color wired remote controller (PC-ARFG2-A)

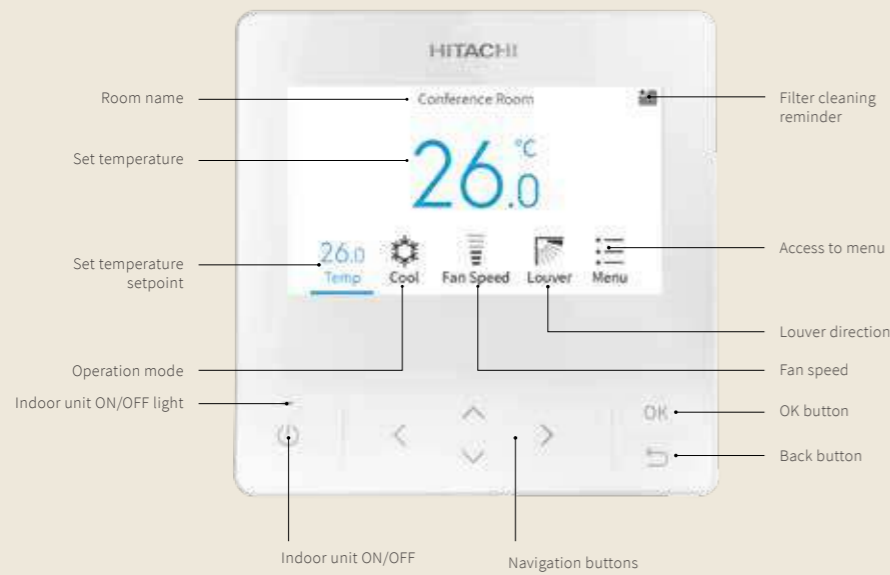

Outer dimensions (H×W×D)
120*×120×16.5mm (thinnest)
120*×120×21.5mm (thickest)

*H is the height of the unit from the front, without the protrusion at the bottom.



System configuration example

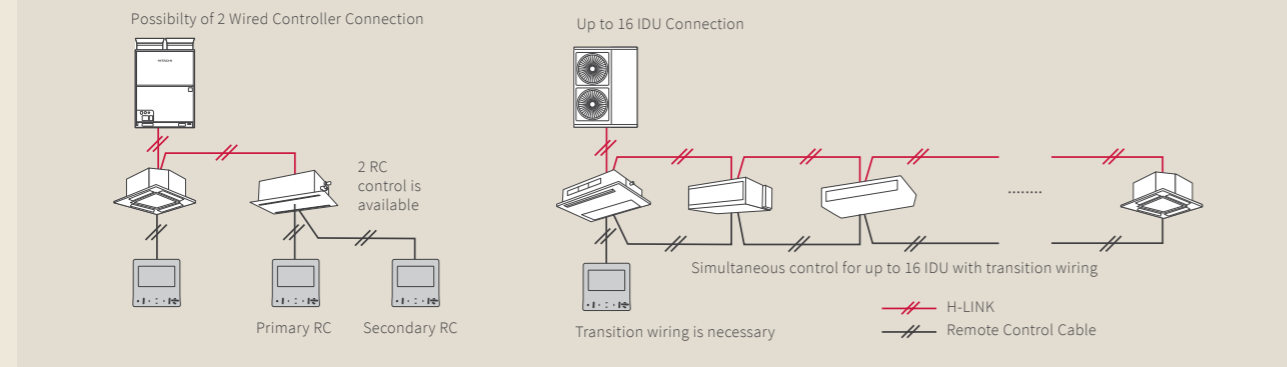

Functions

<ul style="list-style-type: none"> Simple Timer Operation Schedule Power-Saving Setting Night Quiet Operation Power-Saving/Night Quiet Schedule Autoboost Comfort Setting Motion Sensor Setting Setback Setting Elevating Grille Reset Filter Reminder Time Filter cleaning FrostWash™ Setting Individual Louver Setting Louver Open/Close Ventilation Total Heat Exchanger SET Adjust Date/Time Run Indicator Brightness Display Adjustment Temperature Language Setting Chinese (Simplified/Traditional), Japanese English(C/F), French, Portuguese, Spanish 	<ul style="list-style-type: none"> Lock Function Password Setting Hotel Mode Power Saving Detail Setting Set upper and lower limit of setting temperature for auto mode and auto dual setpoint Dual Setpoint Main/Sub Display Set Room Name Set Contact Information NFC Setting Simple Maintenance 	<p>NEW Setup the backup and rotation operation for multiple refrigerant system, usually required for applications like computer room</p> <ul style="list-style-type: none"> Setting Initialization Main Remote Setting Priority Setting Cancel Preheating Control Elevating Grille Setting Power Up Setting Setback Trigger Unit Check 1 Check 2 Alarm History Display Display Model Number Check PCB of the Units Self Check
--	---	---

airCloud Tap Use your phone to set the Controller!

NEW

The Advanced Color Controller is NFC-enabled, simplifying the setup and maintenance via the airCloud Tap app. The app offers illustrations, visual guides and descriptions, saving you time and making the process easier than ever.

App highlights

Installation & commissioning



Room address

Room address

Use your mobile phone's keypad to quickly type in each room name.

Date/Time setting

Import time and date settings from your mobile phone directly into the Advanced Color Controller.

airCloud Tap time-saving tip

Save your setting preferences inside the app to quickly apply them again later. A simple tap is all it takes to copy, paste and apply your saved settings. This is particularly useful for multiple zones with similar needs, e.g. hotel guestrooms, office meeting rooms, condominium units, etc. Users can specify all the settings for one zone, save them, then apply these settings to other zones in one tap.

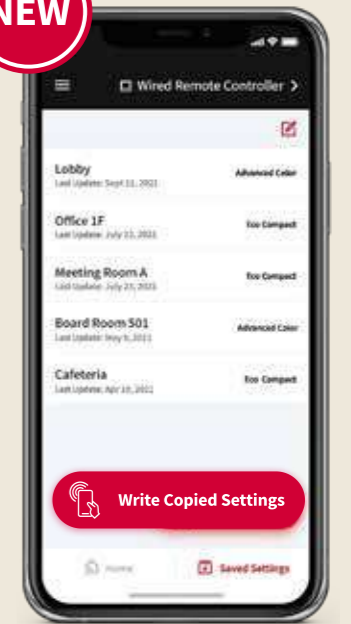

Simple 4-step 'Read & Write' process

Operation



Function selection

Function selection

Browse over 140 features and edit settings quickly via the app.

Scheduling

View weekly schedules clearly and make quick adjustments easily.

Maintenance & service



Error & history

Troubleshooting

Complete service check data is displayed including connected indoor and outdoor units, refrigeration cycle information, sensor data, and more.

Error alarm & history

Error alarm codes and their descriptions are displayed on the app; error histories can be forwarded to support the servicing of controllers.

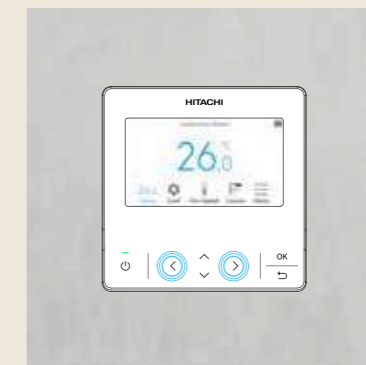

1 Activate the NFC function on the controller.

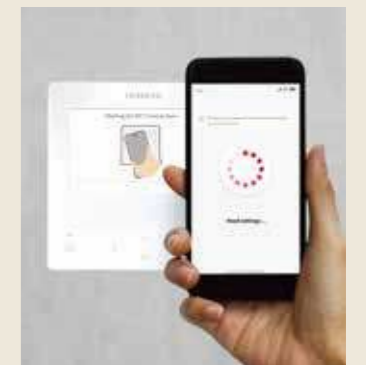

2 Open the airCloud Tap app and tap the controller with your phone to create a connection.

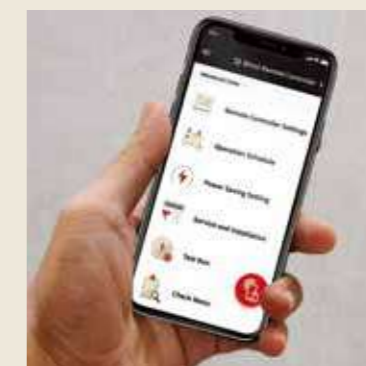

3 Edit the desired settings on your phone. You don't need to be close to the controller while editing.



4 Tap the controller with your phone to write the new settings and apply them to the controller.



*In selected countries from Dec-2021

*In selected countries from Jan-2022

airCloud Tap is available for free in Google Store and IOS appstore. Quick sign up with minimal personal information.



Advanced Color wired remote controller (PC-ARFG1-A)

NEW
Eco-Compact Controller (PC-ARC-A)



Outer dimensions (H×W×D)
90×90×15.5mm (thinnest part)
90×90×18.5mm (thickest part)

System configuration example

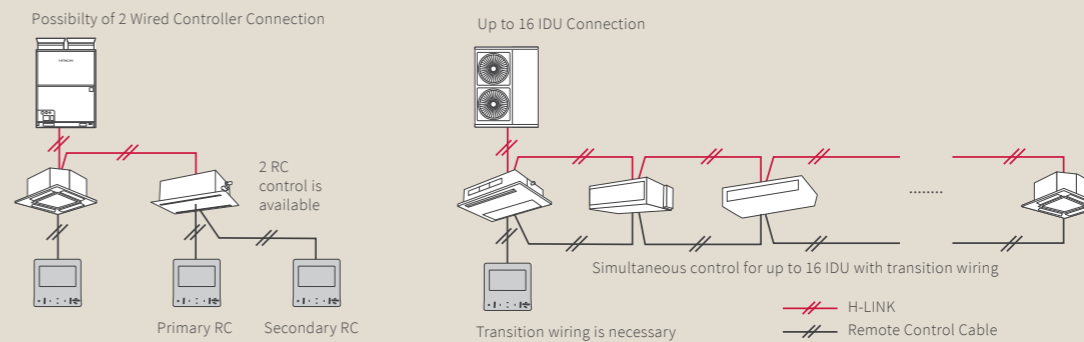

Functions

Controller setting	Current time display	Advanced user controls	Operation schedule	Essential AC controls	Prohibition after forced stop
	Clock synchronization with central controller NEW		schedule ON/OFF		Alarm monitor, Alarm reset
	Room Temperature display		Simple timer		Alarm history
	°C/°F unit selection		Sleep Mode timer NEW		Emergency operation
	Backlight		Comfort setting (GentleCool)		Indoor unit address and refrigerant system No. change
	Embedded IR receiver NEW		AutoBoost		Check 1, Check 2 (troubleshooting)
	Embedded thermistor		Individual louver control (for ceiling cassettes)		Controller Self-check
	NFC airCloud Tap communication NEW		Power saving setting (Peak-cut)		The Eco-compact controller does not support the following functions: cassette elevating grille, FrostWash, and motion sensor-related features. Please note this is not an exhaustive list.
	Language: English (+ Arabic in PC-ARC-U)		Filter sign (time) reset		
	Start/Stop		Function selection		
Set temperature	Test run				
Louver position (air flow direction)	Installation & service				
Fan Speed	Input & output settings	Temperature upper and lower limits			
Operation Mode	Operation lock				
	Temperature upper and lower limits				

Individual controllers

Wired remote controller (HCWA10NEGQ)

Temperature display
Room temperature
RT 26.0°C RT 79.0°F

Set temperature
SET 26.0°C SET 79.0°F

ON/OFF button
Mode button

Operation mode

- Cooling mode ❄️
- Heating mode ☀️
- Dry mode 💧
- Fan mode 🌀
- Auto mode 🔄

Fan speed setting
Fan speed (flickering) MAX

Timer/Clock setting

Timer setting

- ON Timer ON
- OFF Timer OFF
- ONCE Timer valid for one time
- DAILY Timer valid for one day
- WEEKLY Timer set for a week

Liquid Crystal Display (LCD) screen
Up button & down button

Outer dimensions (H×W×D)
(mm) 88.0×88.0×15.5

Functions

	Run/Stop
	Operation Mode
	Auto Mode Setting
	Temperature Setting
Setting	Temperature Setting Rate 0.5°C/1.0°C/1.0°F
	Back-light screen
	Fan Speed 3/4/6 taps
	Louver Direction
	Key touch sound
Service	Sensor Condition Check
	Sensor Data Check
	Alarm History Display
	Test Run
	Function Selection (Optional Function Setting)
Test Run	Thermistor Selection
	Thermistor Calibration
	Input / Output Setting
	Indoor Unit Address Change
	Operation Lock/Set
Management	Lower Limit for Cooling Operation
	Upper Limit for Heating Operation
Schedule	Simple Timer (On/Off)
	Date/time setting

Notes:

1. Fan speed taps setting unit availability varies with the indoor unit. Please check each technical catalog in advance.
2. Initial setting of temperature display is "Set temperature" display only. Please contact your dealer to display room temperature.

Advanced wireless remote controller (PC-AWR)

Transmitter

Transmitting indication
LCD (Liquid Crystal Display)

Mode selection switch
Reset switch

Timer switches

Fan speed switch
On switch
Off switch

Louver angle switch
Temp. switch
Filter reset switch

Outer dimensions (H×W×D)
(mm) 140.0×55.0×16.8

Functions

	Run/Stop
	Operation Mode
	Auto Mode Setting
	Temperature Setting
Setting	Temperature Setting Rate 0.5°C/1.0°C/1.0°F
	Fan Speed 3/4/6 Taps
	Louver Direction
	Filter Sign Reset
Service	Side-by-side indoor unit identification
	Temperature Unit °C/°F
Schedule	Built-in Timer (On/Off)

Wireless remote controller (PC-LH7QE2)

Transmitter

Transmitting indication
LCD (Liquid Crystal Display)

Run/Stop switch

Timer switches

Temp. switch
Louver angle switch
Reset switch

Outer dimensions (H×W×D) (mm) 140.0×52.0×19.3

Functions

	Run/Stop
	Operation Mode
	Auto Mode Setting
Setting	Temperature Setting
	Temperature Setting Rate 1.0°C
	Fan Speed 3/4/6 Taps
	Louver Direction
Service	Side-by-side indoor unit identification
	Temperature Unit °C
Schedule	Built-in Timer (On/Off)

Receiver kit for wireless remote controller

Receiver Kit Model	HR4A10NEWQ	PC-ALHC1	PC-ALHD1	PC-RLHN12QE	Inbuilt	PC-RLH11	PC-RLH11	Inbuilt
Description	4-way cassette	4-way cassette compact	2-way cassette	1-way cassette	Floor/Ceiling convertible	In-the-ceiling	Floor concealed	Hi wall
IDU type								
Model	RCI-FSKDNQ	RCIM-FSN4	RCD-FSR	RCIS-FSKDNQ	RPFC-FSNQ*	RPIZ-HNATNQ RPIL-FSNK RPIM-FSNK	RPFI-FSNQ	RPK-FSNK1/2 RPK-FSRM
Compatible wireless remote controller	PC-AWR	PC-LH3E	PC-LH7QE2					

* Wireless remote controller is provided as standard item for RPFC-FSNQ models.

Centralized controller (mini) cannot be operated when you use standard receiver kit (PC-RLH11) equipped with wireless remote controller (PC-LH3C).

Notes:-

When you use standard receiver kit (PC-RLH11 or HR4A10NEWQ) equipped with wireless remote controller (PC-LH3C):

- 1) Setting Hi2 air flow rate is not available even if the connected Indoor Unit has Hi2 air flow rate setting.
- 2) It is not available to set up "remote control switch operation prohibited by each function setting" from central station (mini).
- 3) It is not available to set up "remote control switch temperature setting range limitation function" from central station (mini).

H-LINK: enjoy more freedom

What is H-LINK?

H-LINK is Hitachi Cooling & Heating original communication system to control multiple VRF refrigerant systems from one centralized control point.

H-LINK simplifies commissioning and service maintenance for installers and service engineers. For building owners and occupants, it provides outstanding versatility enabling the connection of various types of central control options, enabling better system management. Our proprietary high-performance communication system enables the connection of control wiring between indoor and outdoor units, and between a centralized control system and indoor/outdoor units across two or more refrigerant systems.

Examples



Educational institutions such as primary schools where installation work cannot be performed on weekdays.



Hotels where it is preferable to complete installation work during late evenings.



Rehabilitation facilities or hospitals where it is necessary to minimize the burden on users.

3x
more
benefits!

1

Flexible wiring routes:
no restrictions & time-saving at installation.

2

Can connect with various types of Hitachi air conditioning products, including VRF and mini splits, for centralized controls.

3

No adapter is needed!
Simple connection to terminal blocks.

Definition of terms in Hitachi centralized control systems

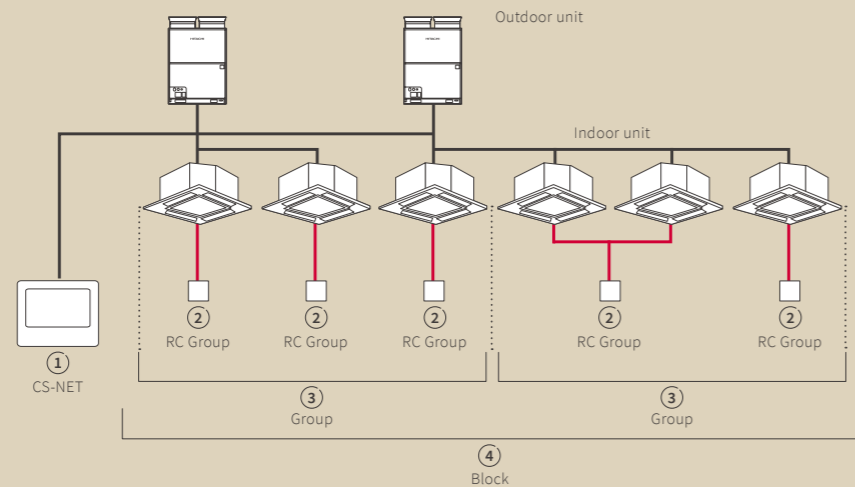

- ① CS-NET/Central station
→ Hitachi original centralized controller.
- ② RC Group (Remote Controller System Group)
→ Stands for a number of indoor units (up to 16 units) connected using "same remote controller" wiring. In this group, connected indoor units are all controlled in the same way.
- ③ Group
→ Stands for the multiple "RC groups" that are registered in the centralized controller network setting.
- ④ Block
→ Stands for the multiple "groups" that are registered in the centralized controller network setting.

Centralized controls: Flexible wiring route!

- (1) • Multiple refrigerant systems located in one area.
- Central monitoring room in separate area.

H-LINK SOLUTION

- Wire the central station to the closest indoor unit.
- Wiring distance is reduced substantially.

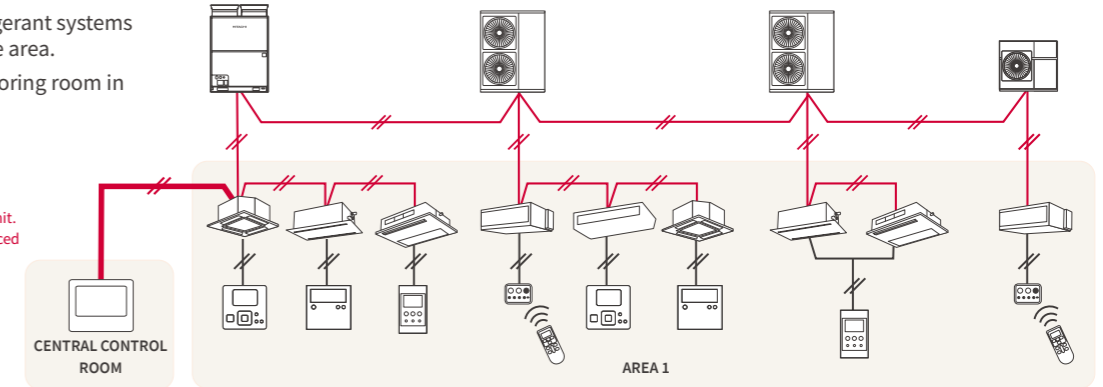

- (2) • Refrigeration systems in different places.
- Some indoor units of each respective system are close to one another.

H-LINK SOLUTION

- Where two indoor units of each respective system are close together: you can connect two refrigerant systems via the indoor units.
- Wiring distance is reduced substantially.

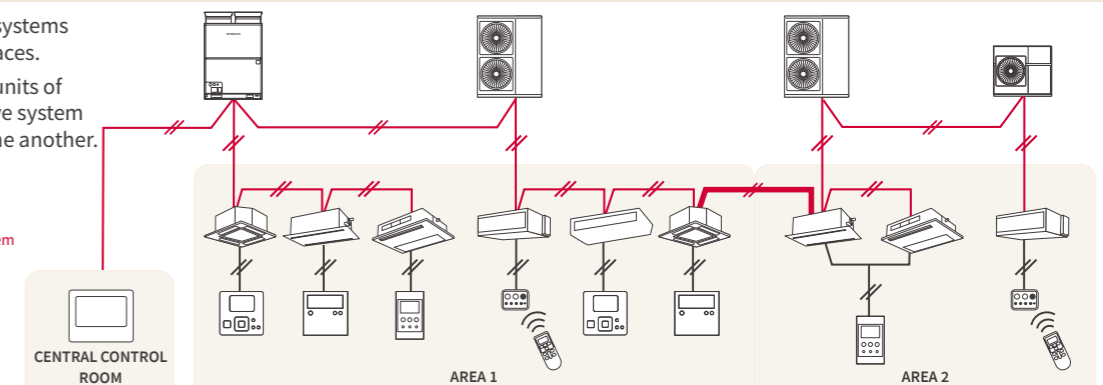

- (3) • One refrigerant system far away from the remaining ones.

H-LINK SOLUTION

- Connect the farthest refrigerant system directly to central station either to outdoor units or indoor units.
- The central station can make the central link between the different refrigerant systems.

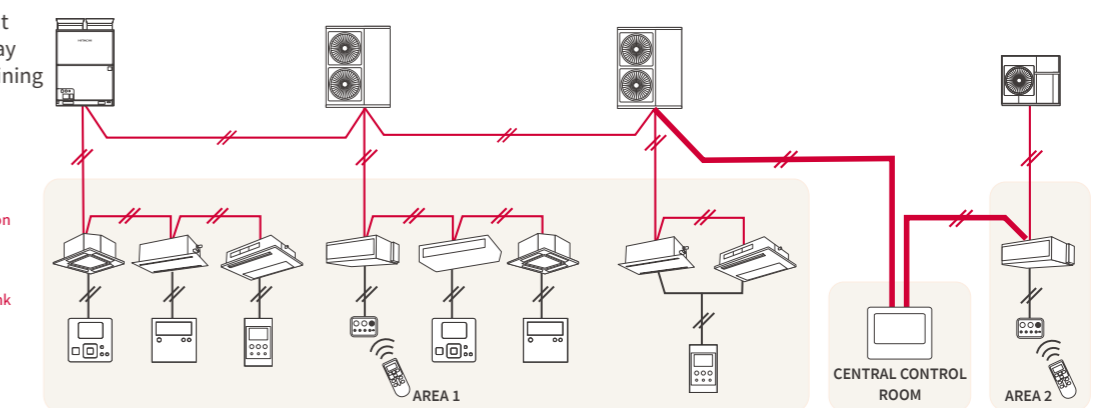

- (4) • Each refrigerant system in separate areas.
- Indoor units are closer from one group to another.

H-LINK SOLUTION

- Centralized control can be achieved by connecting the refrigerant systems via the closer indoor units.
- Wiring can be indoors only.

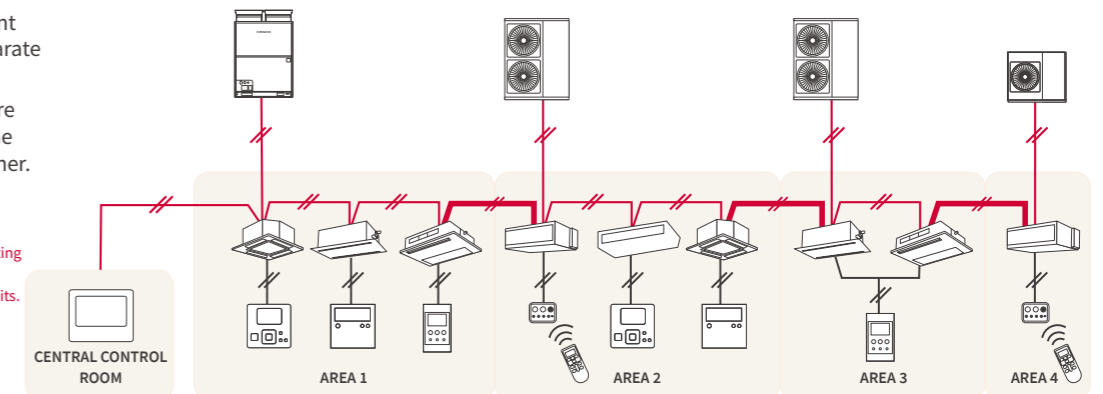

— H-LINK solution — H-LINK — Remote control cable

