

USER MANUAL

TRUE SINEWAVE

HOME UPS / INVERTER/MPPT SOLAR PCU



Dear Customer, Congratulations on Your Purchase!

Thank you for choosing our Inverter / Home UPS / Solar PCU. This user manual is designed to provide you with all the necessary information for safe and efficient operation of your device. Please read this manual carefully before installing and using the Inverter / Home UPS/Solar PCU.



External Battery Packs



Home Appliances

We wish you many years of reliable and efficient performance with your Inverter / Home UPS / Solar PCU.

Electrical Shock Hazard:

Warning: To reduce the risk of electrical shock, always disconnect AC power supply and solar panels before performing any maintenance or servicing on the Inverter / Home UPS / Solar PCU.

Caution: Never attempt to open the Inverter casing while it is connected to the power source. Doing this cause dangerous electrical shock.

Fire & Burn Hazard:

Warning: Do not operate the Inverter / Home UPS / Solar PCU in areas where the flammable gases or vapors present. This could lead to fire or explosion.

Caution: Avoid placing any objects on top of the inverter, as they may obstruct ventilation and cause overheating.

Maintenance & Service Instructions:

Regularly inspect the inverter for any signs of damage or wear. If you notice any issues, immediately disconnect the power supply and contact a qualified technician for assistance.

Keep the inverter clean and free from dust accumulation, as this can affect its performance and lifespan.

It is recommended to have the Inverter / Home UPS / Solar PCU serviced by authorized personnel at least once a year to ensure optimal operation.

Only use compatible batteries with the Inverter / Home UPS / Solar PCU. Using incompatible batteries may damage the inverter and void the warranty.

Do not expose the inverter to extreme temperatures or humidity levels, as this can affect its performance and lifespan.

Always use insulated tools while working with the device to prevent electrical shock.

Home UPS Installation Instructions:

Place the Inverter / Home UPS / Solar PCU in a well-ventilated area away from direct sunlight and moisture.

Recommended to Install in a cool place less < 30 Deg C.

Connect the solar panels to the designated input ports on the device, ensuring proper polarity.

Connect the AC mains to the line neutral and earth.

Connect the output terminals of the inverter to the electrical appliances you wish to power.

Switch on the device using the power button and monitor its operation to ensure everything is functioning correctly.

System Connections at the Back Panel:

The system has following options for connecting your devices:

- 1) Output Socket : For connecting Load / Home Appliances
- 2) Solar Connector (For Solar Models): For connecting Solar Panels as Per Rating of the Inverter.
- 3) Battery Wires : Connect these to Battery Terminals with Bolt & Nut in case external batt.
- 4) Mains Lead: For Connecting to Mains Input
- 5) Fuse / CB : This is Used to Protect the Overload or Failure from Overload in Mains Mode
- 6) Fan : For Colling the Internal Parts.

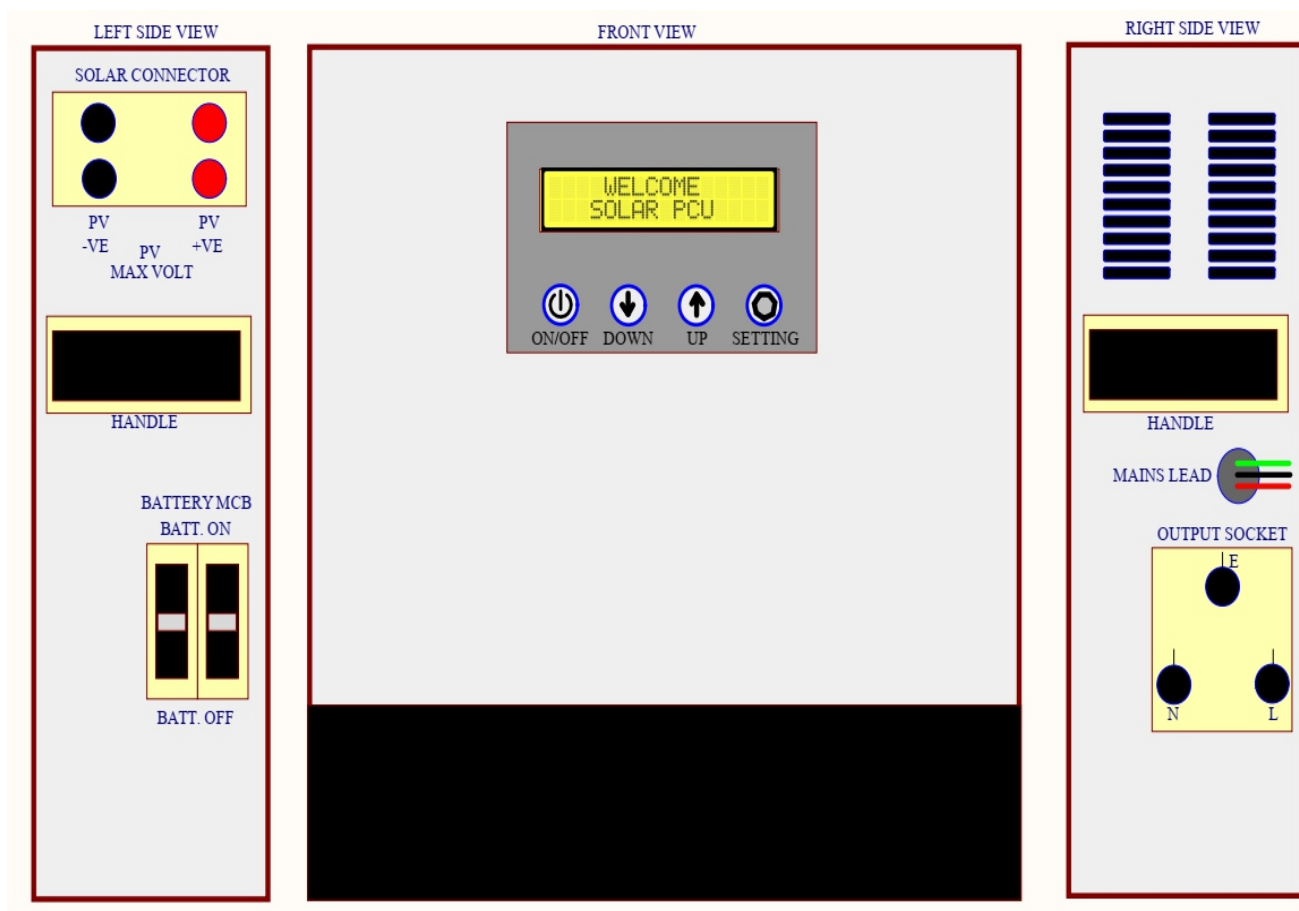

LITHIUM BATTERY HOME UPS
FRONT & SIDE PANEL

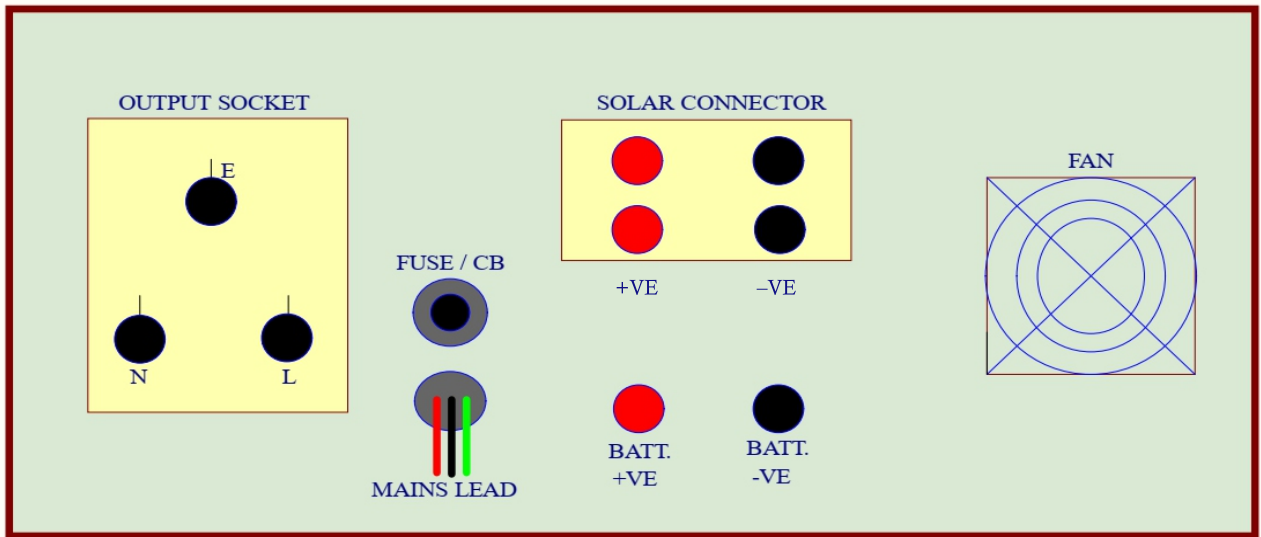

HOME UPS 12V BACK PANEL

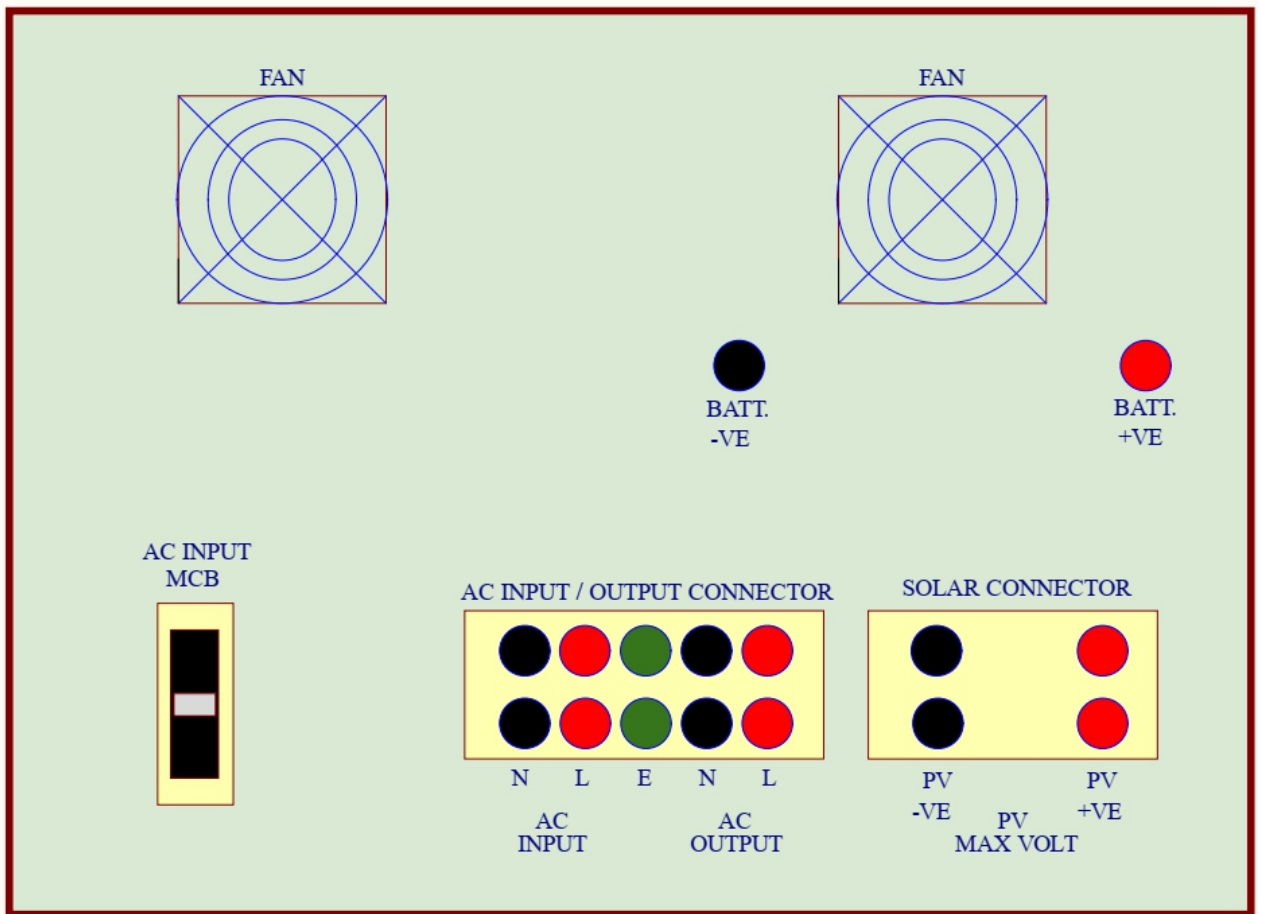

HOME UPS 24V BACK PANEL

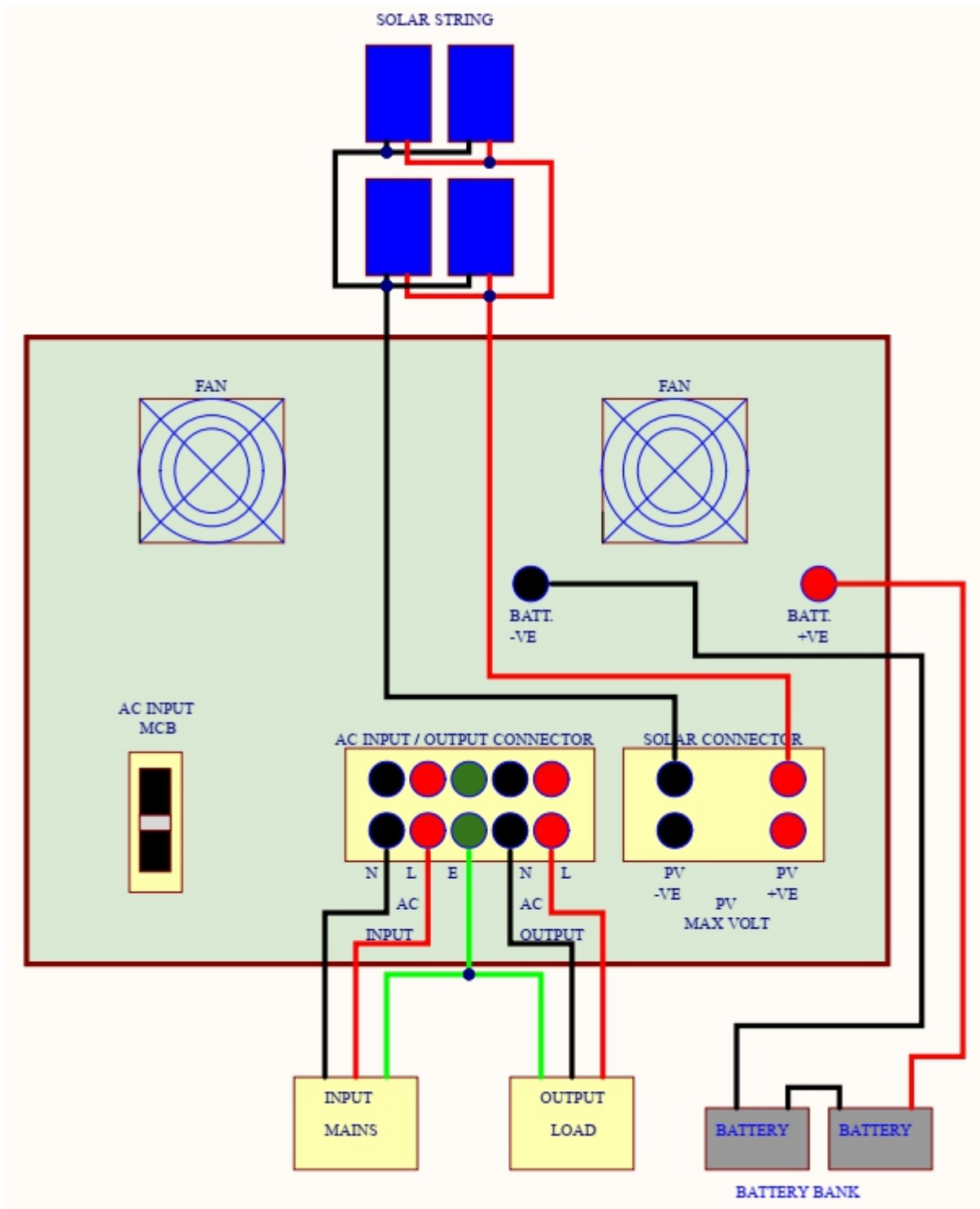

HOME UPS /INV: Wiring Diagram for 12V/ 24V / 48V (External Battery Models)

NOTE:

Ensure that all the Connections are done as per Rating of the Inverter & Markings Given on the System Or it may void the Warranty. It should be done by Authorized personal only.

Specifications:

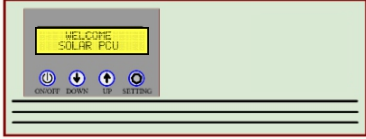
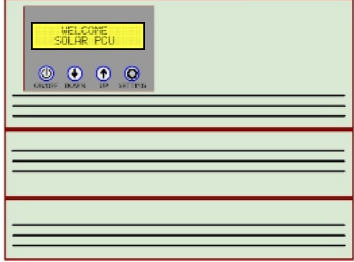
INVERTER SPECIFICATIONS							
PRODUCT PICS							
MODEL	PS-700	PS-900	PS-1100	PS-1600	PS-2100	PS-2500	PS-3000
Capacity in VA	700VA	900VA	1100VA	1600VA	2100VA	2500VA	3000VA
Battery Voltage	12V	12V	12V	24V	24V	24V	24V
BULB LOAD (WATT)	560	720	880	1240	1680	2000	2400
POWER FACTOR	0.8	0.8	0.8	0.8	0.8	0.8	0.8
DISCHARGING CURRENT (DC AMP)	45	60	70	56	68	85	100
SOLAR VOC RANGE PWM	20V-50V	20V-50V	20V-50V	35V-50V	35V-50V	35V-50V	35V-50V
SOLAR VOC RANGE MPPT	26V-60V	26V-60V	26V-60V	35V-100V	35V-100V	35V-100V	35V-100V
MAX SOLAR INPUT CURRENT	40A	40A	50A	50A	50A	50A	70A
RECOMMENDED SOLAR PANEL	100WP-200WP	100WP-200WP	100WP-200WP	250WP-400WP	250WP-400WP	250WP-400WP	250WP-400WP
SOLAR PANEL CONNECTION TYPE	ALL PANEL PARALLEL	ALL PANEL PARALLEL	ALL PANEL PARALLEL	ALL PANEL PARALLEL	ALL PANEL PARALLEL	ALL PANEL PARALLEL	ALL PANEL PARALLEL

PACKAGE INCLUDES

1 x HOME UPS Unit

1 x User manual

Note:

- i) We supply only the UPS / INV Unit thus, Wires are not the part of the system.
- ii) Warranty is only applicable for Manufacturing Defects of the UPS/INV Unit only if any & there is no warranty on Mechanical Parts.

Key Features:

NO.	FEATURES	ADVANTAGE FOR CUSTOMER
1	BATTERY EQUALISATION MODE	CAN GET LONGER BACKUP & MAINTAIN BATTERY HEALTH
2	ZERO VOLT CHARGING PICKUP	GET TROUBLE FREE OPERATION
3	TAPERED CHARGING TECHNOLOGY	WILL DECREASE WATER TOP-UP FREQUENCY & LOW BATTERY MAINTENANCE (POWER COST SAVING AS WELL)
4	READY TO LITHIUM & FOR LITHIUM INVERTER TWO LEVEL BATTERY HIGH LOW CUT SETTING	IN FUTURE CUSTOMER CAN SWITCH LITHIUM BATTERY, NO NEED TO BUY NEW LITHIUM SUPPORTED INVERTER
5	THREE LEVEL GRID CHARGING SETTING (8A,12A,16A)	WILL INCREASE BATTERY LIFE
6	POWER SAVING MODE INVERTER COST RECOVER IN 3-4 YEAR (OPTIONAL FEATURE)	CUSTOMER CAN RECOVER INVERTER COST IN 3-4 YEAR & REST OF LIFE WILL ENJOY THE POWER SAVING
7	30-40V STABILIZER FUNCTION (OPTIONAL/ADDITIONAL)	WILL BOOST TO GRID VOLTAGE by 30-40V , SUPPOSE GRID INPUT VOLTAGE IS 180V , INVERTER WILL GIVE 220V & WORK AS a STABILIZER & SIMULTANEOUSLY WILL KEEP MAINTAIN INVERTER FUNCTION ALSO.
8	IOT READY (WITH MODBUS COMMUNICATION FOR RMS)	CAN GET REMOTE MONITORING
9	UPS MODE	NO NEED TO KEEP EXTRA UPS FOR COMPUTER APPLICATION
10	GRID CHARGING DISABLE MODE CONFIGURABLE USER SELECTABLE	IF BATTERY IS NOT DISCHARGE FROM LONG TIME ,CUSTOMER CAN STOP BATTERY CHARGING THROUGH GRID CHARGING DISABLE FUNCTION. DURING THIS TIME LOAD WILL FEED BY GRID IN BYPASS MODE & IN ABSENCE OF GRID BATTERY WILL SUPPORT TO LOAD, ONCE BATTERY WILL BE EMPTY THEY CAN START GRID CHARGING. IN THIS PRACTICE BATTERY HEALTH WILL BE MAINTAIN & WILL GET GOOD BACKUP & BATTERY LIFE
11	BEEP SOUND IN UPS MODE CONFIGURABLE USER SELECTABLE	INVERTER WILL PASS BEEP SOUND IN UPS MODE TO INDICATE LOAD IS SUPPORTED BY BATTERY SO THAT CUSTOMER CAN GET ALERT, IF WORKING ON COMPUTER.
12	ENABLED WITH A (SMART POWER SAVING TECHNOLOGY) *OPTIONAL*	GREAT POWER SAVING WILL SAVE 10-12UN T MONTH , WILL SAVE RS.1200-1500/YEAR
13	WIDE INPUT VOLTAGE RANGE FROM 90V-285V	IDEAL FOR RURAL CUSTOMER
14	TRUE PWM TECHNOLOGY FOR SOLAR INVERTER	ENABLED WITH SMART ENERGY SAVER FUNCTION
15	2X QUICK CHARGING ON SOLAR (20AMP & 25 AMP)	CAN GET FAST BATTERY CHARGING ON SOLAR SYSTEM
16	TRUE MPPT TECHNOLOGY	WILL GET MAXIMUM POWER FROM SOLAR PLANT, WILL INCREASE POWER SAVING.
17	FACTORY RESET FEATURE	TO AVOID ANY CONFUSION & FOR EASY UNDERSTANDING OF THE WORKING
18	LCD SCREEN HOLD FEATURE	CAN SEE REQUIRED WINDOW ALWAYS TIME SAVING

Operating Manual

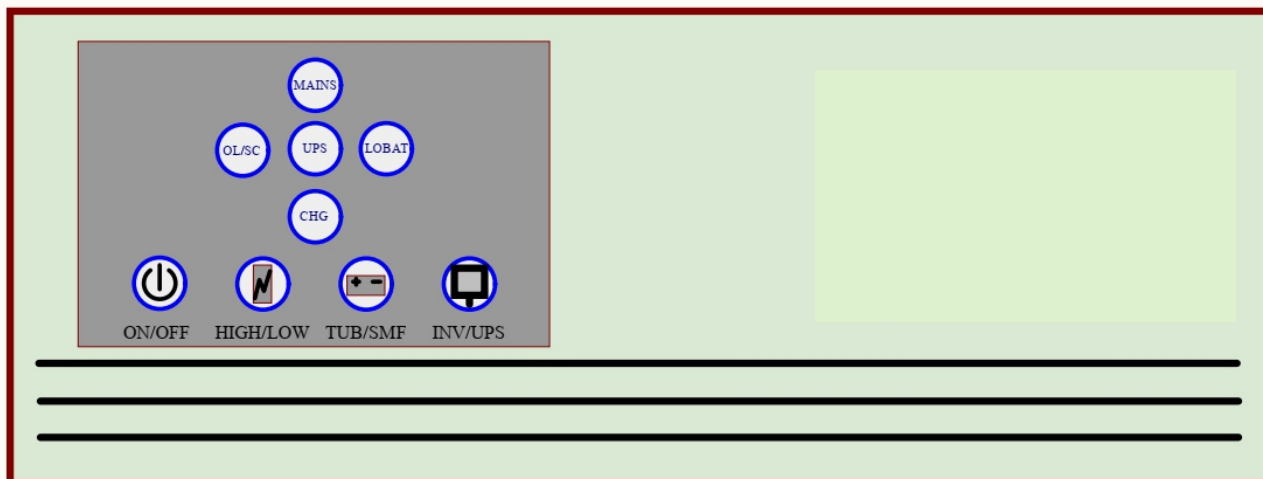

IDEAL FOR RURAL CUSTOMER

LED MODEL'S FRONT PANEL

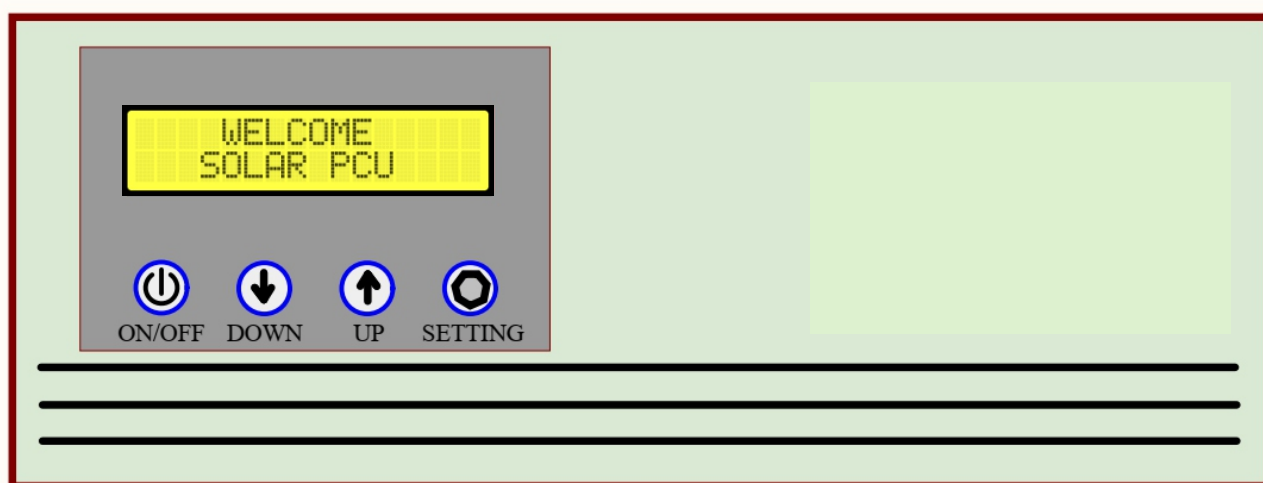

LCD MODEL'S FRONT PANEL

Functional description to BUTTONS / SWITCHES / KEYS / LED / LCD on FRONT panel

1. ON/OFF SWITCH - To Switch On the Backup Mode.
2. HIGH/LOW SWITCH (**DOWN**) – To Select the Battery Charging current from Mains or to change the LCD Options.
3. TUB / SMF (**UP**) - To Select the Battery Type or to Change the LCD Options.
4. INV / UPS (**SETTINGS**) - To Select Backup Type / Mode & To Enter the LCD Menu.

Initial Operation

- 1) Connect the INV/UPS to the Battery Terminals Using Nut & Bolts
- 2) LCD Will display its Welcome Screen & then will starts to scroll.
- 3) Following Home Auto Scrolling Screens Regularly rotates one by one in sequence.

Sr. No.	PARAMETERS LCD SCREEN	LCD SCREEN STATUS	Remarks
H1	WELCOME SOLAR PCU	WELCOME SOLAR PCU	WELCOME SCREEN
H2	BKUP SWIT:ON BKUP MODE:INV	BKUP SWIT:ON BKUP MODE:INV	BACKUP SWITCH STATE BACKUP MODE
H3	GRID STAT:OFF LOAD PERC:0%	GRID STAT:OFF LOAD PERC:0%	GRID STATUS LOAD PERCENTAGE
H4	BATT VOLT:29.0V BATT CRNT:2.7A	BATT VOLT:29.0V BATT CRNT:2.7A	BATTERY VOLTAGE BATTERY CHG. AMPERE
H5	GRID VOLT:0V GRID FREQ:0.0Hz	GRID VOLT:0V GRID FREQ:0.0Hz	GRID VOLTAGE GRID FREQUENCY
H6	OUTP VOLT:220V OUTP FREQ:50.0Hz	OUTP VOLT:220V OUTP FREQ:50.0Hz	OUTPUT VOLTAGE OUTPUT FREQUENCY
H7	GRID CHGF:EN BATT EQZN:OFF	GRID CHGF:EN BATTERY EQZN:OFF	GRID CHG. FUNCTION BATTERY EQUALISATION STATUS
H8	LOAD STAT:S+B	LOAD STAT:S+B	LOAD RUNNING STATUS
H9	BATT TYPE:TTB CHG TYPE:16A	BATT TYPE:TTB CHG TYPE:16A	BATTERY TYPE CHARGING TYPE
H10	SOL STATE:ON ESA LEVEL:25.0V	SOL STATE:ON ESA LEVEL:25.0V	SOLAR STATUS ENERGY SAVER LEVEL
H11	SOL OPAMP:8.1A	SOL IPVOLT:45.0V SOL OPAMP:8.1A	SOLAR INPUT VOLT SOLAR OUTPUT AMPERE
H12	SOL POWER:200W ESA STATE:OFF	SOL POWER:200W ESA STATE:OFF	SOLAR POWER INPUT ENERGY SAVER STATE

Setting / Configuring the system:

- 1) Press Setting Switch.
- 2) System will ask for confirmation as below, then again has to press Setting Switch to Login to admin panel.



- 3) Press UP / DN KEY to EDIT MENU Options & Press Setting Switch to Move forward One by one

Sr. No.	PARAMTERS LCD SCREEN	Description (Defaults)	Remarks
S1	***MENU*** BKUP MODE: INV	BKUP MODE:INV (BACKUP MODE)	Select Backup Mode UPS /INV
S2	***MENU*** BATT TYPE:TTB	BATT TYPE:TTB (BATTERY TYPE)	Select Battery Type TTB/FTB/SMF/LP3 LP1/LP2/LP3/LP4
S3	***MENU*** GRID CHGA:16A	GRID CHGA:16A (GRID CHARGING AMPERE)	Select Battery Charging Ampere from Mains 8A/12A/16A
S4	***MENU*** AUTO SCRL:EN	AUTO SCRL:EN (AUTO SCROLL)	Enable / Disable AUTO SCROLL LCD SCREENS
S5	***MENU*** ESA MODES:EN	ESA MODES:EN (ENERGY SAVER MODES)	Enable / Disable Energy Saver Mode
S6	***MENU*** ESA REC V:25.0V	ESA REC V:25.0V (ENERGY SAVER RECOVERY VOLTAGE)	Select Energy Saver Recovery Voltage 12.5V/12.0V/11.5V/11.0V.
S7	***MENU*** SOL CHG A:20A	SOL CHG A:20A (SOLAR CHARGING CURRENT)	Select Battery Charging Ampere from Solar 20A/25A
S8	***MENU*** SOL CHGF :EN	SOL CHGF :EN (SOLAR CHARGING FUNCTION)	Enable / Disable SOLAR CHARGING FUNCTION
S9	***MENU*** EXT MENU:DIS	EXT MENU:DIS (EXTENDED MENU)	Enable / Disable EXTENDED MENU

- 4) Complete the setup & Then Press Setting Switch to Go to Home Screens
- 5) There are Some Extended Menu Items Also which can be seen by Changing the EXT MENU : EN (Enable).

6) Extra Menu Options are as Follows:

Sr. No.	PARAMTERS LCD SCREEN	Description (Defaults)	Remarks
SE1	***MENU*** BATT EQZN:OFF	BATT EQZN:OFF (BATTERY EQUALIZATION)	ON /OFF BATTERY EQUALIZATION FEATURE
SE2	***MENU*** GRID CHGF:EN	GRID CHGF :EN (GRID CHARGING FUNCTION)	Enable / Disable GRID CHARGING FUNCTION
SE3	***MENU*** UPS BEEPS:DIS	UPS BEEPS:DIS (UPS MODE BEEPS)	Enable / Disable BUZZER BEEPS IN UPS MODE
SE4	***MENU*** SOL CHGF :DIS	SOL CHGF :DIS (SOLAR CHARGING FUNCTION)	Enable / Disable SOLAR CHARGING FUNCTION
SE5	***MENU*** SW:01.1/07C24	SW:01.1/07C24 (SOFTWARE VERSION)	SOFTWARE VERSION
SE6	***MENU*** HW:30BLT04410	HW:30BLT04410 (HARDWARE VERSION)	HARDWARE VERSION

TROUBLESHOOTING

(WARNINGS)

SN	WARNINGS LCD SCREEN	LED & BUZZER INDICATIONS	Remarks
W1	*** WARNING *** INV OVERLOAD	OL/SC LED BLINK BUZ BEEPS	Reduce Load
W2	*** WARNING *** LOW BATTERY	LB LED BLINK BUZ BEEPS	Give Time to Charge Battery
W3	*** WARNING *** OVER TEMPERATURE	ALL LED BLINK BUZ ON	FAN is Faulty Inverter Ventilation Issue
W4	*** WARNING *** PV REVERSE	PV LED ON BUZ ON	Solar Reverse Check PV Connection
W5	*** WARNING *** PV CRNT HI	PV LED FAST BLINK BUZ ON	PV Current High Reduce Solar Panel
W6	*** WARNING *** PV VOLT HI	PV LED BLINK BUZ ON	Solar Voltage High Check Solar Volt

(TRIP ERROR LIST)

Sr. No.	TRIP ERROR LCD SCREEN	LED & BUZZER INDICATIONS	Remarks
T1	***** TRIP ***** INV OVERLOAD	OL/SC LED ON BUZ ON 45 SEC.	REDUCE LOAD AND SWITCH ON THE INVERTER
T2	***** TRIP ***** LOW BATTERY	LB LED ON BUZ ON 45 SEC.	BATTERY NEEDS TIME TO CHARGE
T3	***** TRIP ***** BATT VOLT HIGH	LB LED ON BUZ ON 45 SEC.	BATTERY INPUT VOLTAGE HIGH WRONG BATTERY CONNECTED
T4	***** TRIP ***** SHORT CIRCUIT	OL/SC LED ON BUZ ON 45 SEC.	OUTPUT SHORT OR INV CARD FAULT
T5	***** TRIP ***** OP FB OPEN	INV LED BLINK BUZ ON 45 SEC.	CHECK THE FEEDBACK WIRE
T6	***** TRIP ***** MAINS MCB TRIP	MAINS LED ON BUZ ON 45 SEC.	OUTPUT OVERLOAD OR OUTPUT SHORT CHANGE THE FUSE
T7	***** TRIP ***** MAINS IN OP SKT	OL/SC LED ON BUZ ON 45 SEC.	MAINS INPUT & INV. OUTPUT SHORT CHECK THE WIRING
T8	***** TRIP ***** OVER TEMPERATURE	ALL LED ON BUZ ON 45 SEC.	CHECK TERMISTOR, FAN, VENTILATION
T9	***** TRIP ***** NTC OPEN	ALL LED ON BUZ ON 45 SEC.	CHECK NTC THERMISTOR
T10	***** TRIP ***** PV OVER VOLT	PV LED ON BUZ ON 45 SEC.	REDUCE PV VOLT *

MENU OPTION

S.NO.	PARAMETERS LCD SCREEN	MODE	DESCRIPTION
1	BKUP MOE :INV BACKUP MODE	INVERTER MODE	GRID INPUT /VOLTAGE RANGE 90 /- 280 / AC THIS MODE USE FOR RURAL / VILLAGES AREA AND THIS DEFAULT MODE
		UPS MODE	GRID INPUT /VOLTAGE RANGE 180 /-265 / AC THIS MODE USE FOR IT APPL CATION LIKE COMPUTER AND THIS SETTABLE
2	BATT TYPE : LP3LC BATTERY SELECTION TYPE	LP16C	THIS MODE IS CC (CONSTANT CURRENT) MODE IN THIS MODE BATTERY BOOST /VOLTAGE // LL BE 14.0 / AND BATTERY LO // /VOLTAGE ALARM // LL BE 12.4 / AND BATTERY LO // CUT /VOLTAGE // LL BE 12.0
		LP3LC	THIS MODE IS C / (CONSTANT /VOLTAGE) MODE IN THIS MODE BATTERY BOOST /VOLTAGE // LL BE 14.0 / AND BATTERY LO // /VOLTAGE ALARM // LL BE 12.4 / AND BATTERY LO // CUT /VOLTAGE // LL BE 12.0 THIS DEFAULT MODE
3	GRID CHGA :16 A GRID CHARGING	8A ,12A ,16A	BATTERY CHARG NG THROUGH GRID IS SETTABLE 8AMP 12A 16A
4	AUTO SCRL:EN AUTO SCROLL SELECTION	EN/DIS	IN CASE //ANT TO SEE PART CULAR PARAMETER YOU CAN HOLD THE SCREEN ,
5	SOS MODES:SSS SOLAR MODE SELECTION	SSS	SOLAR PR OR TY //ORK NG SOLAR +BATTERY LEAST USE OF GRID ENERGY IN DAY TIME
		SSA	BATTERY PR OR TY - BATTERY +SOLAR +GRID , IN E /EN NG //HEN SOLAR IS OFF AND BATTERY NEAR BY FULL /VOLTAGE , INVERTER // LL NOT CONNECT // TH GRID , IN THAT COND TION LOAD // LL BE OPERATE THROUGH BATTERY T LL BATTERY M/A NS RECONNECT /VOLTAGE AND IN THIS MODE BATTERY // LL NOT CHARGE FULL THROUGH GRID , // LL CHARGE APPROX 70% . IN THIS MODE BATTERY FULL CHARGE // LL BE FROM SOLAR ONLY
		SSB	GRID PR OR TY- IN THIS MODE BATTERY AL //AYS // LL BE FULL THROUGH GRID AND SOLAR AND F GRID-SOLAR IS AVAILABLE AND BATTERY IS FULL CHARGES THEN LOAD // LL BE OPERATE BY GRID ONLY , SOLAR // LL NOT BE USED, //HEN GRID POWER FAILED , SOLAR // LL START & LOAD // LL BE OPERATE ON SOLAR+BATTERY
6	SOL CHG A: 20 A SOLAR CHARGING SELECTION	20A/30A/40A	BATTERY CHARG NG THROUGH SOLAR IS SELECTABLE , DEFAULT SETTING 20A, IF FAST CHARG NG REQUIRED , MORE CHARGING AMP CAN BE SET.
7	SOL CHGF : EN SOLAR CHARGING SELECTION	EN/DIS	TO S // TCH OFF THE SOLAR CHARG NG CURRENT (IN CASE ANY EMERGENCY)
8	EXTD MENU : DIS EXTENDED MENU SELECTION	EN/DIS	FE // MORE FEATURES // LL APPEAR AND THAT IS NOT REGULAR USABLE FOR CUSTOMER
EXTENDED MENU			
9	LCNL		LO // CUT NO LOAD LO // CUT PARAMETER IS SETTABLE
10	LCFL		LO // CUT FULL LOAD LO // CUT PARAMETER IS SETTABLE
11	BOOST VOLTAGE		BATTERY BOOSTER FULL /VOLTAGE IS SETTABLE
12	GRAVITY VOLTAGE		GRA / TY /VOLTAGE FOR TUBULAR BATTERY IS SETTABLE
13	FLOAT VOLTAGE		FLOAT VOLTAGE IS SETTABLE
14	CHARGING TPR		NOT FOR END USER.
15	UPS BEEP MODE		IN UPS MODE BEEP SOUND // LL BE ACT /ATED
16	AUTO BACKUP MODE	EN/DIS	IN THIS MODE THE SYSTEM WILL TURN ON AUTOMATICALLY WITHOUT THE ON/OFF SWITCH.
17	SYSTEM RESET	EN/DIS	IN THIS MODE THE SYSTEM WILL BE TURN TO FACTORY SETTING.

TROUBLE SHOOTING

S.NO.	PROBLEM	LCD/BUZZER	POSSIBLE CAUSE	WHAT TO DO
1	NO OUTPUT	OUTPUT VOLT 0	BACK UP SWITCH OFF	PRESS ON/OFF SWITCH ONCE
2	NO OUTPUT	MAINS FUSE BLOWN	CIRCUIT BREAKER TRIP (RCB)	RESET CIRCUIT BREAKER
3	BUZZER BEEP CONTINUE	BATTERY LOW ALARM	BATTERY LOW	RE-CHARGE BATTERY
4	BUZZER BEEP INTERMITTENTLY	OVERLOAD	TOO MUCH LOADS CONNECTED TO THE INVERTER	REDUCE THE LOAD
5	BUZZER BEEP CONTINUE	PV REVERSE	SOLAR WIRE S CONNECTED WITH THE WRONG POLARITY	DO CORRECT
6	BATTERY NOT CHARGING WITH MAINS	GRID STATUS OFF	IS THE MAIN PLUG CONNECTED PROPERLY	MAIN PLUG COONECTED PROPERLY AND MAIN PLUG SWITCH ON
7	COMPUTER LOAD TRIP	NO ANY INDICATION	IN V MODE SELECTED IN PLACE OF UPS MODE	SELECT UPS MODE
8	SOLAR AMP NOT OPEN	NO ANY INDICATION	SOLAR PANEL VOLTAGE LESS THAN 24VDC	INCREASE SOLAR VOLTAGE FROM PANEL 24-30V
9	INVERTER SHOW SHORT CIRCUIT	SHORT CIRCUIT		RESTART INVERTER FROM ON OFF SWITCH AFTER RESTART INVERTER NOT ON AND SAME MESSAGE APPEAR IN DISPLAY THEN POWER CARD HAVE SOME ISSUES. IN THAT CASE REPORT TO SERVICE TEAM
10	SOLAR CURRENT NOT OPEN	NO ANY DISPLAY, ALL SOLAR PARAMETER SHOW ZERO	MAY BE SOLAR CARDS NOT WORKING	CALL SERVICE TEAM



WARRANTY

Certificate

Customer Name: _____

Address: _____

Model No. _____ Serial No. _____

Purchase Date: _____ Invoice No. _____

Warranty Years / Months : _____

Coverage:

This warranty covers defects in materials and workmanship of the above-mentioned product for the duration specified above.

Dealer Name: _____ Contact No. _____

Signature: _____

Date: _____

