

# U-W Double-Stage

High-Head Submersible Dewatering Pumps

SERIES

- The double (two) stage structure achieves a higher head than other series that are with the same motor output.
- The cylindrical body in protrusions in small diameter is the most suitable pump for drainage in a narrow pit such as deep well drainage.
- The top discharge and the cylindrical water channel provide efficient motor cooling.
- The back pressure releasing mechanism is adopted to enable a long service life of the mechanical seal.(EXCEPT U-282AW)  
\*For more information, refer to page 9.
- Infiltrative water detector is adopted as a motor protector to prevent motor burnout (EXCEPT U-232AW, U-282AW and U-2153AW).  
\*For more information, refer to page 9.
- The impeller is made of ductile cast iron or high chrome cast iron (about 25% chromium) providing excellent wear resistance.
- The pumps are designed for easy maintenance and inspection.  
\*For more information, refer to page 11.



**Option**

Cable Extension

Discharge Modification

Material Change

Heat Resistant

Painting Change

Sacrificial Anode

Lubricant Oil Change

The available options vary depending on the model. For more information, refer to "Option" page 53.

## Applications

- High head pumping applications in narrow spaces

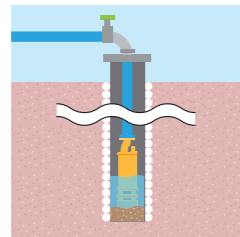

Deep well and well-point drainage

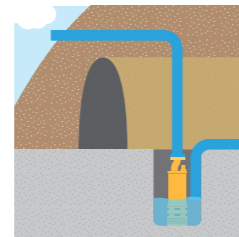

Dewatering on Tunnel shaft



Drainage at basements, underpasses, mining sites, and in open pits

## Performance Curve

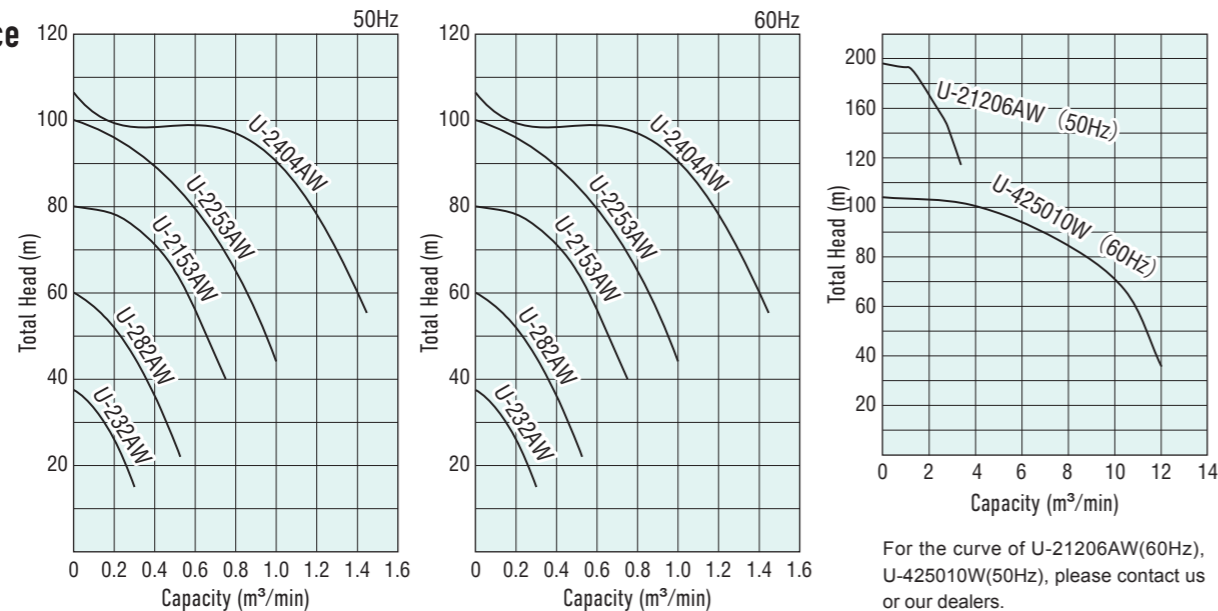

## Main Specifications

Discharge Diameter (mm)	50	50	80	80	100	150	250	
Pump Models	U-232AW	U-282AW	U-2153AW	U-2253AW	U-2404AW	U-21206AW	U-425010W	
Motor Output (kW)	2.2	5.5	11	19	30	90	185	
Medium	Rain Water / Spring Water / Muddy Water							
Temperature	Max 40 Degrees Celsius							
Pump	Shaft Seal: Double Type Mechanical Seal							
	Shaft Bearing: Double-Row Ball Bearing			Duplex Ball Bearing				
	Impeller: *FCD500			High Chrome				
	Semi-open			Closed				
Casing	*FCD500	*FC200	*FCD500					
Motor	Type/Pole: Dry Type Induction Motor/2pole							
	Dry Type Induction Motor / 4pole							
	Insulation Class: E		B			F		
	Protector: Auto-Cut			Auto-Cut + Infiltrative Water Detector		Miniature Thermal Protector + Infiltrative Water Detector		
	Frame: *FC200							
Shaft: Stainless Steel								
Discharge Type: Flange								

\*FCD : Ductile Cast Iron / FC : Cast Iron

## Specifications

Discharge Diameter mm (in)	Pump Models	Motor Output		Total Head		Capacity			Starting	Max Solid Through		Weight (without cable)		Cable Length	
		kW	HP	m	ft	m³/min	m³/hr	USGPM		mm	in	kg	lb	m	ft
50 (2)	U-232AW	2.2	3	26	85	0.2	12	53	DOL	6	0.24	48	106	10	32.8
50 (2)	U-282AW	5.5	8	45	148	0.3	18	79	DOL	7	0.28	105	231	15	49.2
80 (3)	U-2153AW	11	15	65	213	0.5	30	132	DOL	8	0.31	145	319	20	65.6
80 (3)	U-2253AW	19	25	85	279	0.5	30	132	DOL	8	0.31	260	572	20	65.6
100 (4)	U-2404AW	30	40	90	295	1	60	264	DOL	8	0.31	420	924	20	65.6
150 (6)	U-21206AW	90	120	170	561	2	120	528	Star-Delta	11	0.43	1,200	2,640	20	65.6
250 (10)	U-425010W	185	250	74	243	10	600	2,640	Star-Delta	35	1.38	2,250	4,950	20	65.6

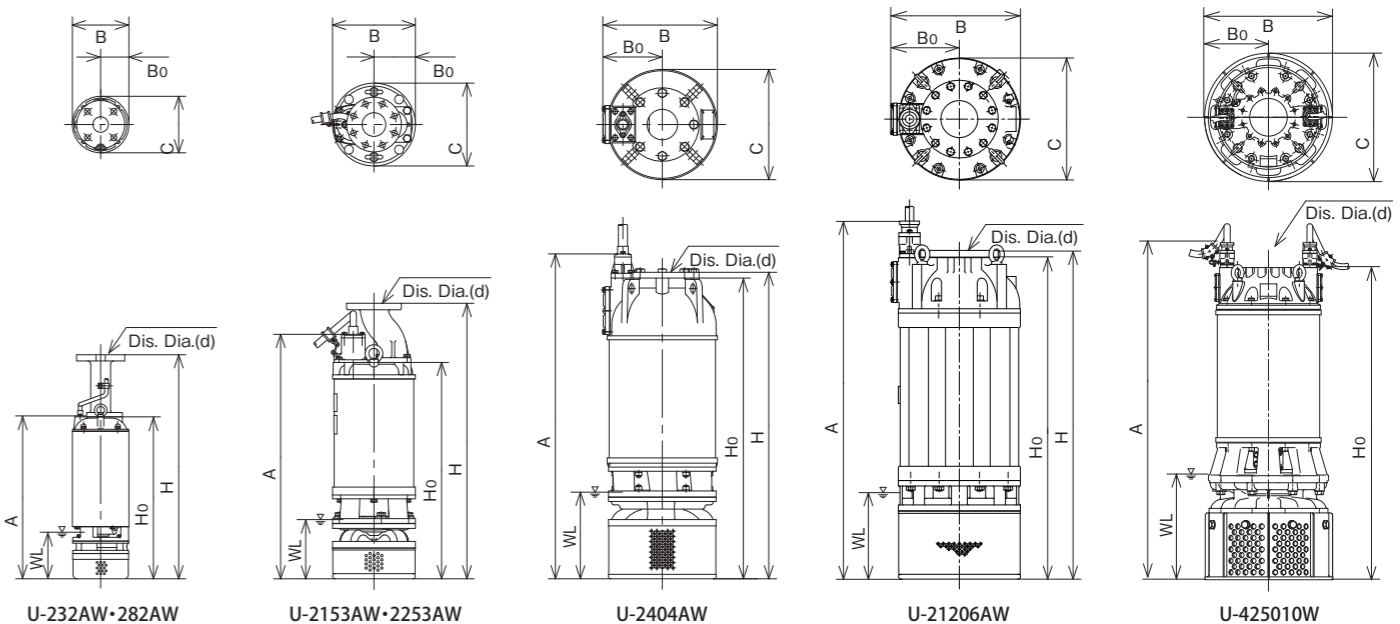

## External Diagrams (mm)

Pump Models	d	H	H <sub>0</sub>	A	B	B <sub>0</sub>	C	WL
U-232AW	50	738	538	541	180	90	180	150
U-282AW	50	831	631	723	250	125	250	190
U-2153AW	80	931	731	826	280	140	280	200
U-2253AW	80	1,160	960	1,055	330	165	330	240
U-2404AW	100	1,168	1,145	1,240	437	227	420	330
U-21206AW	150	1,482	1,450	1,615	583	307	550	400
U-425010W	250	—	2,070	2,235	850	425	850	700

WL : Pump Starting Level

# DEEP DIVE INTO OUR WORKHORSE

# U-425010W

## Long-term Operation for Tough Sites

- Long Cable with Water Protection
- Built-in Miniature Thermal Protector
- High Motor Cooling Efficiency
- Structure for Long-term Use  
-The Back Pressure Releasing Mechanism
- Excellent Impeller Design  
The Impeller has a special “balance ball”. This reduces the load on the mechanical seal and makes it last longer.



✓ Check Page 11

✓ Check Page 9

✓ Check Page 9

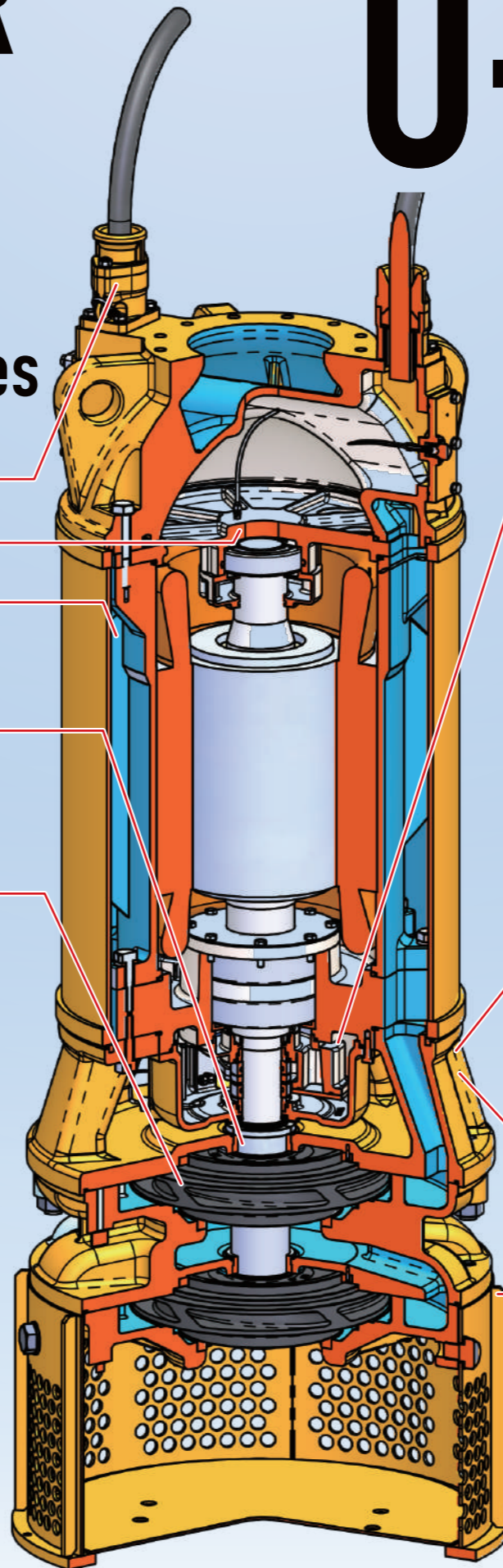

## Efficient Maintenance

### Two Step Water Detector

By adopting a two-phase water detection system using Electrode (Phase1) and Float (Phase2), this system enables planned replacement and helps to reduce the risk of water infiltration into the motor.

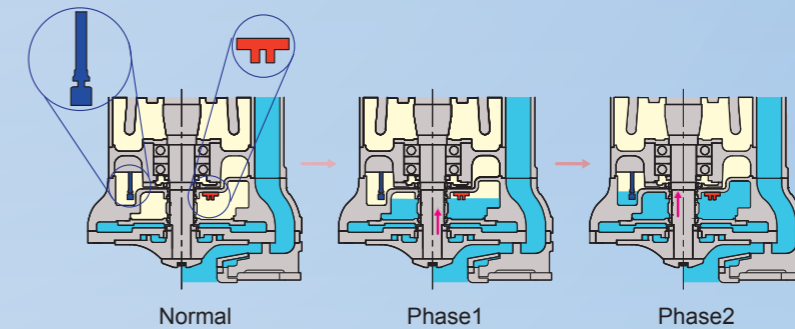

Maintenance work can be prepared after the Phase 1 alarm.

### Greasing without Disassembly

The operator can add grease from the outside without taking the pump apart. This design keeps the pump well-lubricated and helps it last longer.

### Oil Chamber Window

Lubricant oil can be changed while the pump is upright. This can reduce maintenance workload.

### Eyebolts on Strainer to Carry Easily

The adoption of the 4-point support type lifting pieces make transportation and installation of the pump significantly easier.

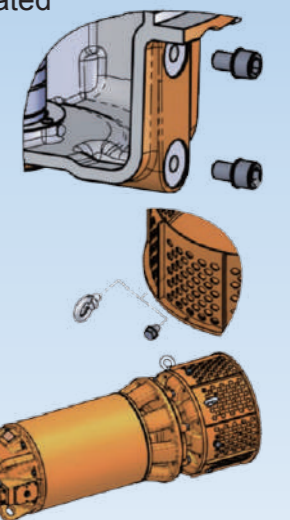

## Main Specifications

Output	185kW (250HP)
Max Total Head	105m (344 ft)
Max Capacity	762m <sup>3</sup> /hr (201,300gph)
Dis.Dia.	250mm (10inch)
Weight	2,250kg (4,960lbs)
Height	2,265mm (7.4 ft)
Phase	Three
Pole	4

**DELIVERING MAXIMUM HEAD, MAXIMUM VOLUME. NO COMPROMISES.**