



# CONCEPTO Dron

**BIOMIMÉTICA**



Proceso de investigación y diseño



# QUÉ?

Utilizando la **biomimética** aportar un concepto de **dron personal** con la capacidad de transportar a una persona de alrededor de 80 kg a **Akxo**.



# OBJETIVOS



Economizar energía



Despegue y aterrizaje  
vertical



Cambio de vertical a  
horizontal



Optimizar relación  
resistencia/peso



Controles intuitivos



Lo más compacto  
posible

✦ 01 ✦

INVESTIGACIÓN

# ANÁLISIS DE PRODUCTOS ANÁLOGOS

## LILIUM JET

300 km/h

Autonomía de 300 km

Capacidad de 5 pasajeros



## BLACKFLY

100 km/h

Autonomía de 40 km

Carga el 80% de su batería en 30 minutos



## HEAVYSIDE

100 veces más silencioso que un helicóptero

Autonomía de 160 km

Capacidad de 80 kg



# Análisis de Contextos

Tipos de drones:

- Militares
- Aviones no tripulados
- VTOL



© DJI Antiflow



# MATERIALES

Fibra de carbono

Keblar

Motor trifásico

Baterías Li-Po

Hélice doble

Nylon

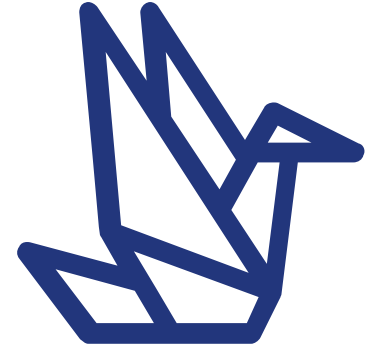

# BIOMIMÉTICA

La biomimética o biomímesis es la imitación de modelos, sistemas o elementos de la naturaleza aplicados a nuestra tecnología. Es decir, que consiste en inspirarnos en dicha naturaleza para desarrollar soluciones tecnológicas.

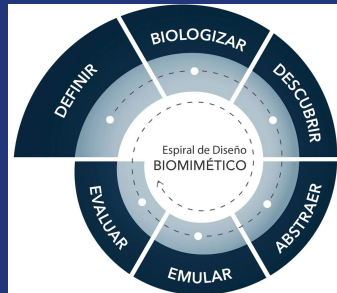

# BIOMÍMESIS 3 CONCEPTOS



**vencejo**

**PETAURO  
DEL  
azúcar**

**MANTARRAYA**



02

FUNDAMENTACIÓN

# EL VUELO (sustentación en el aire)

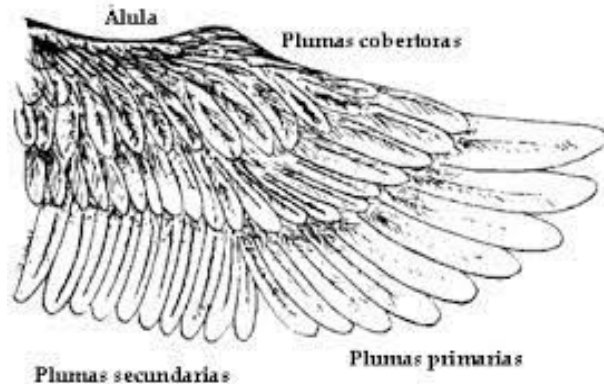
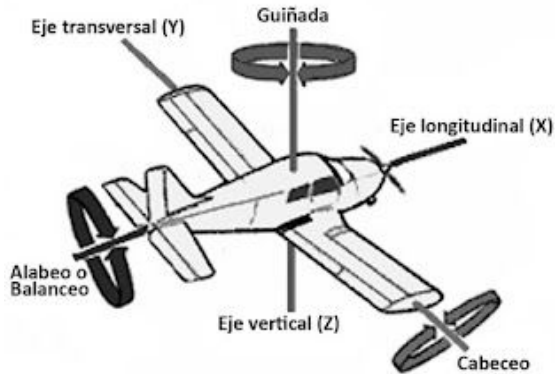
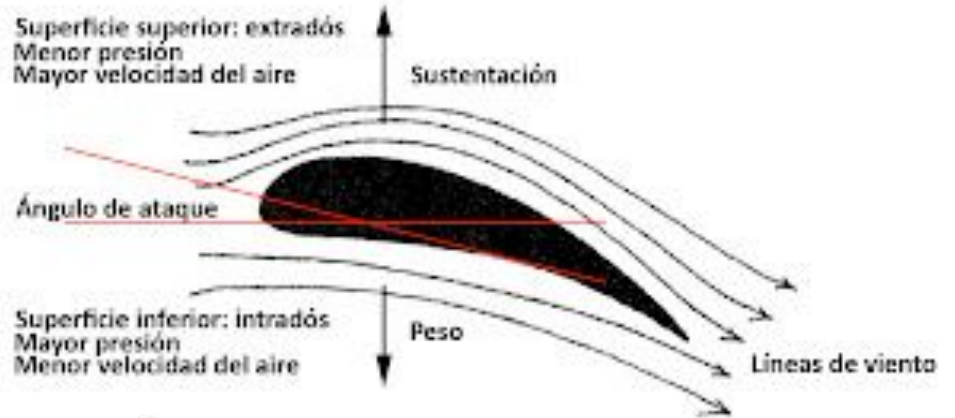
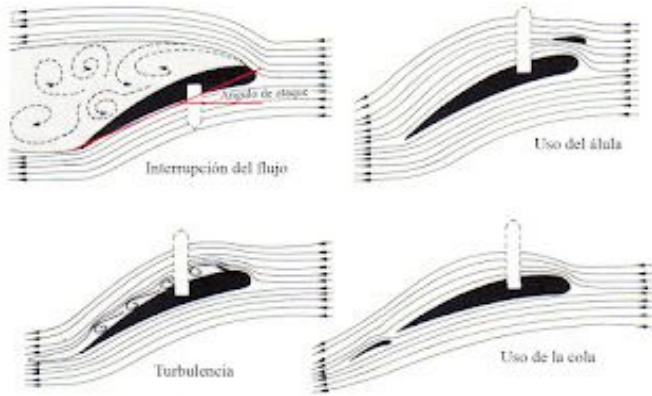

# EL VENCEJO



## AHORRO DE energía

Forma y proporciones (1 de ancho por 4 de largo) optimizadas para el mayor tiempo de planeo



## Anatomía

Presenta silueta en forma de ballesta, cola corta y ahorquillada, y alas estrechas y largas.

✦ 03 ✦

BOCETOS

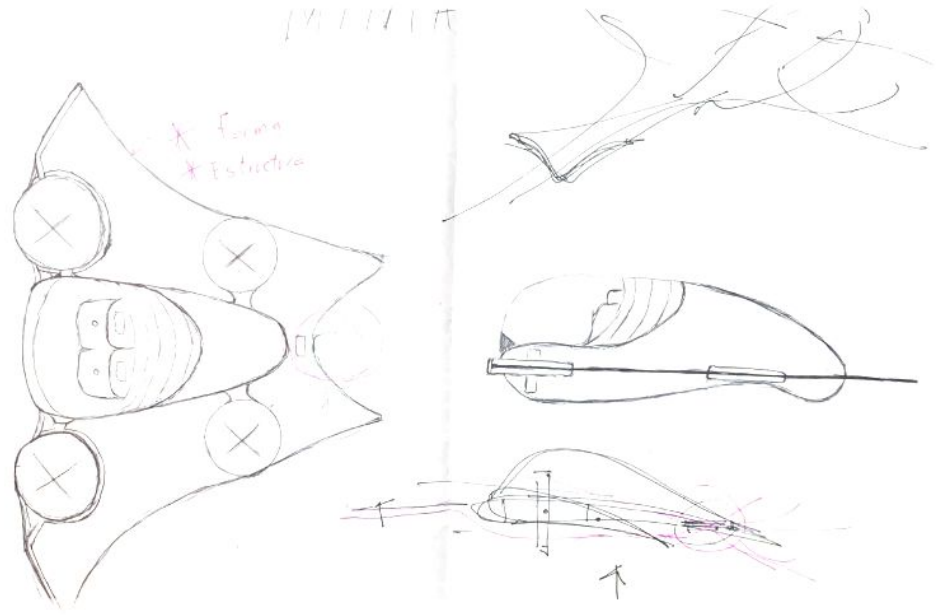
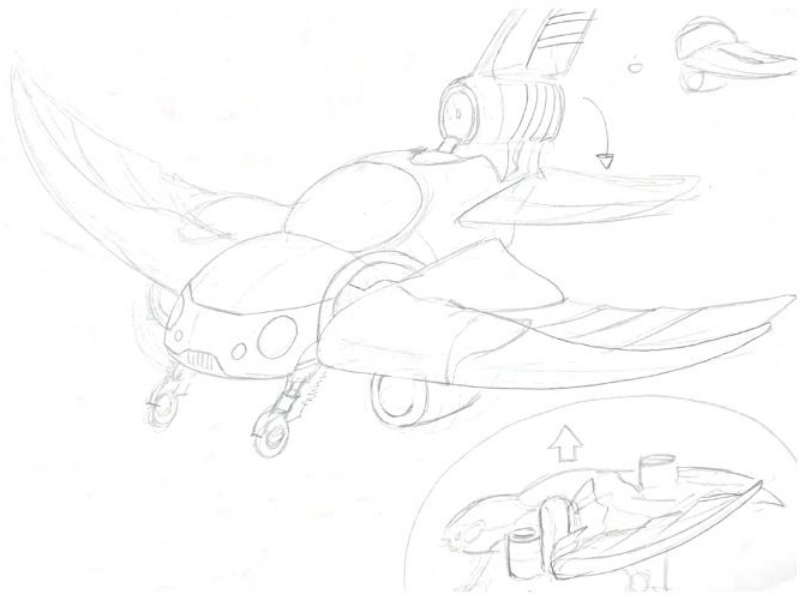



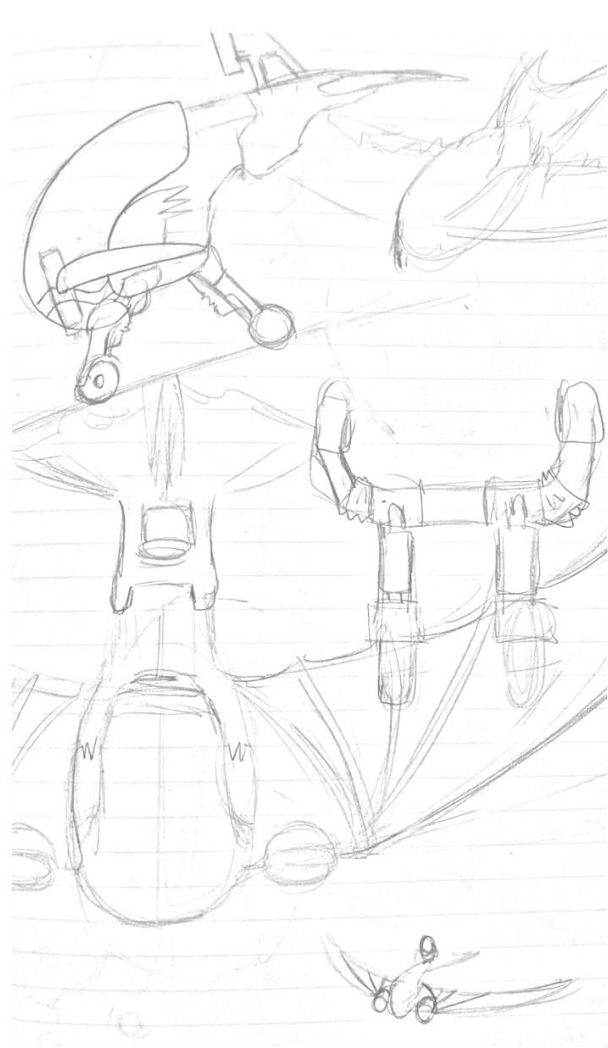
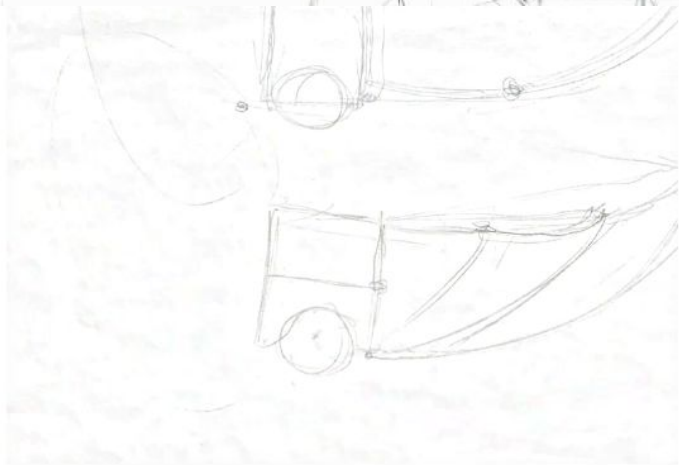
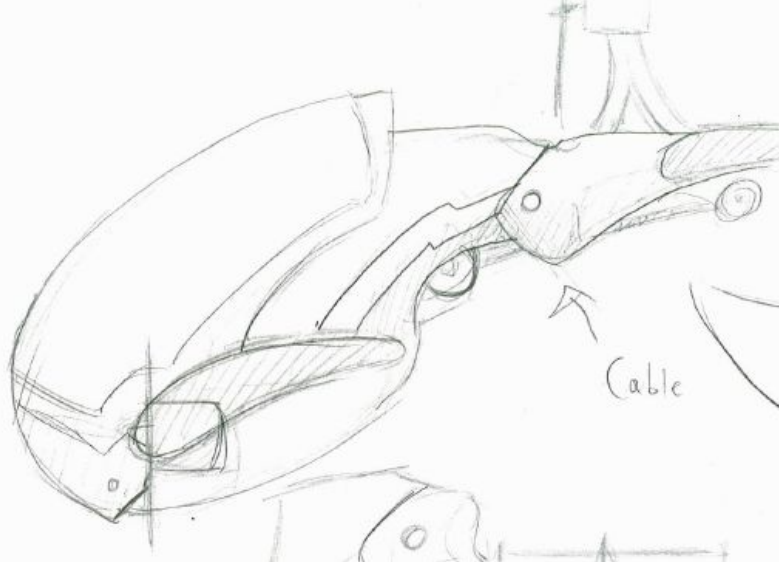

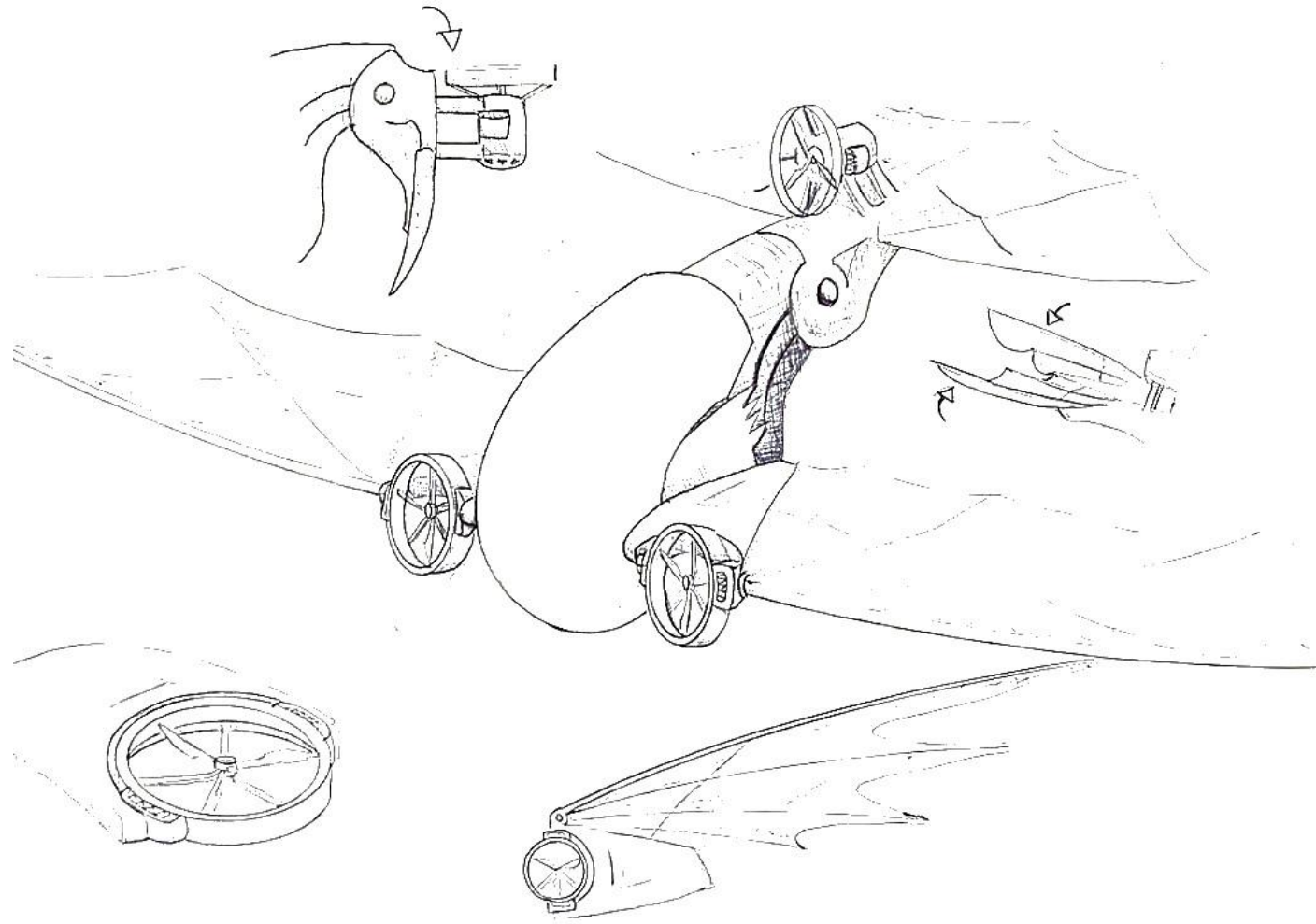

✦ 04 ✦

RENTERS

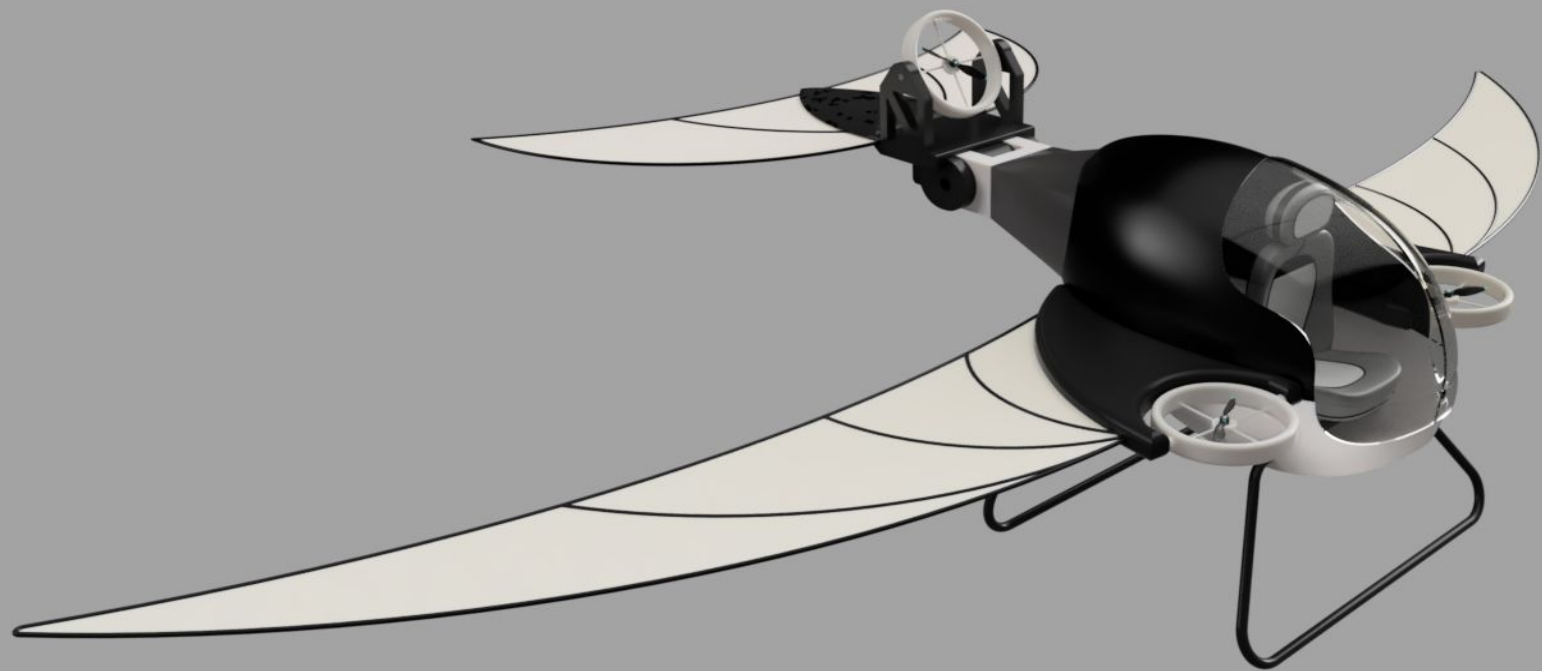

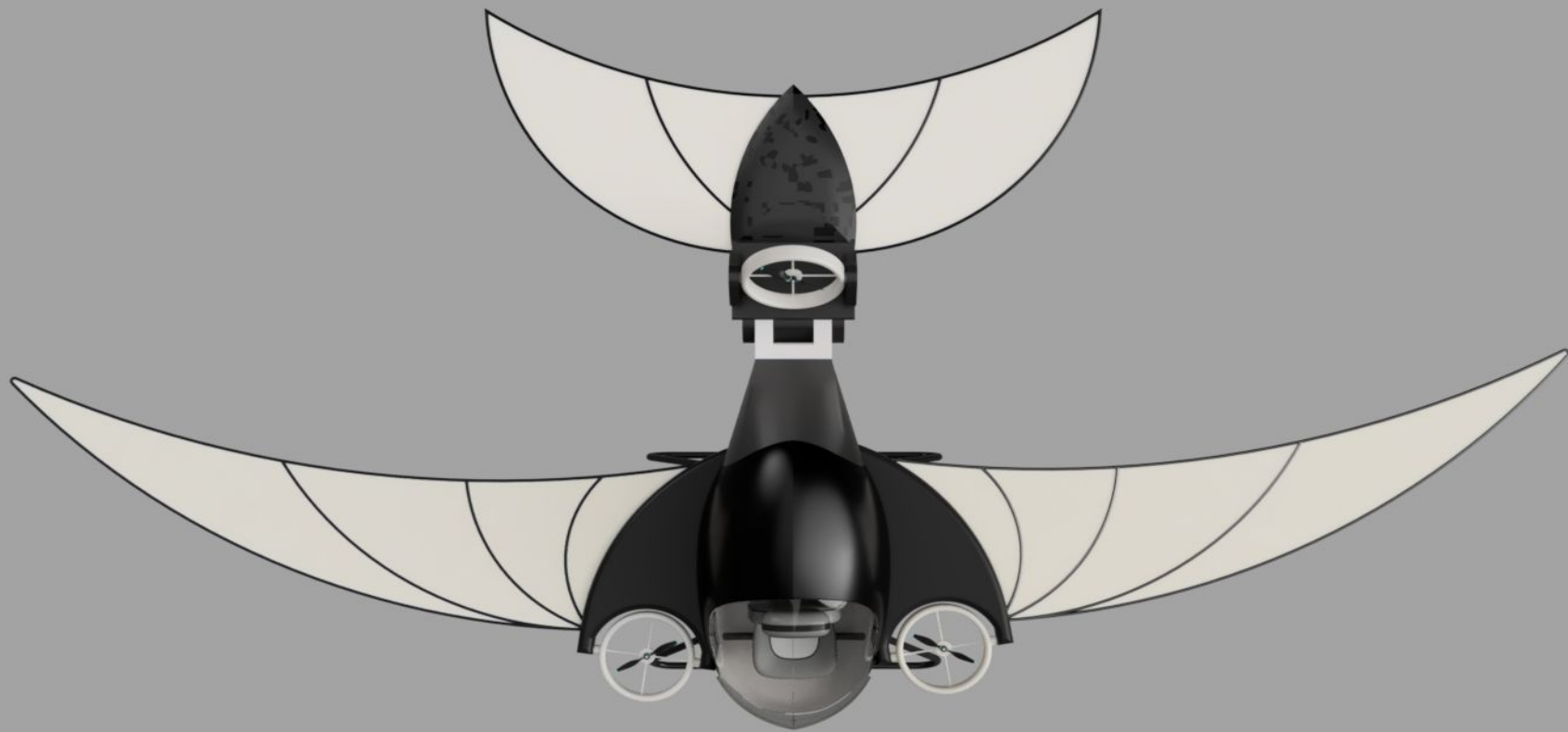

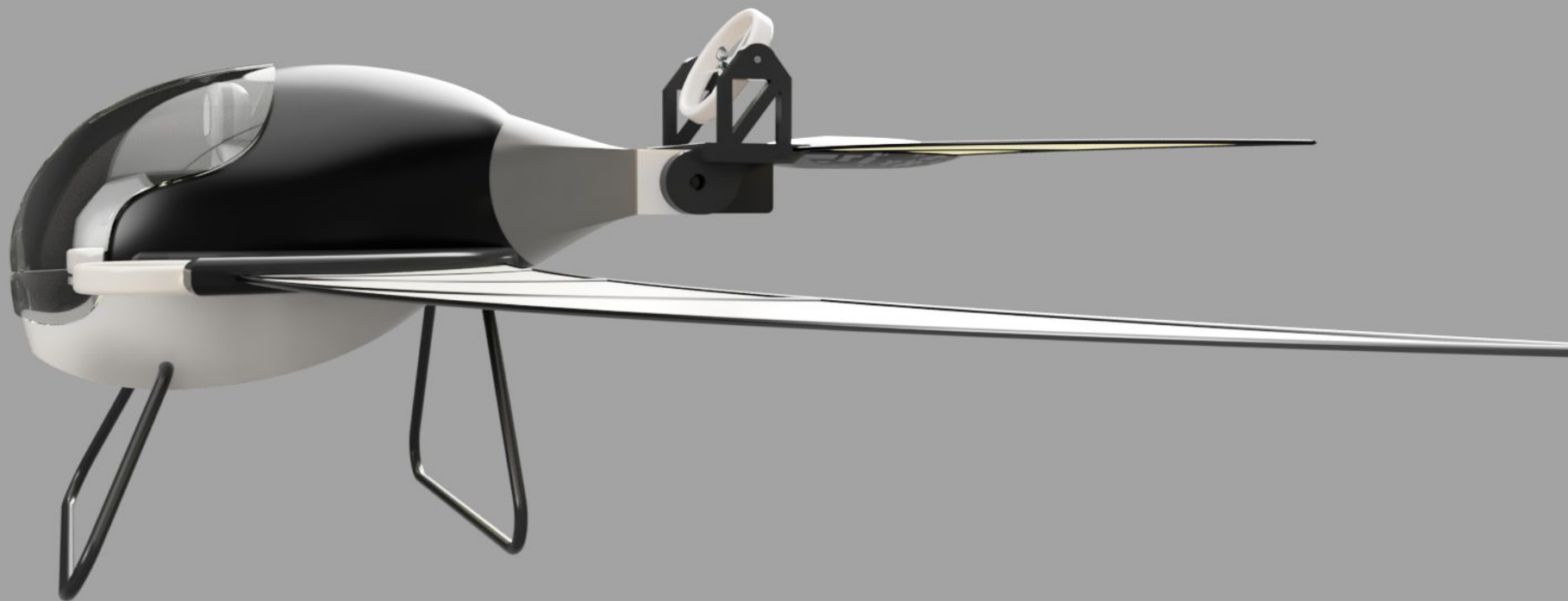

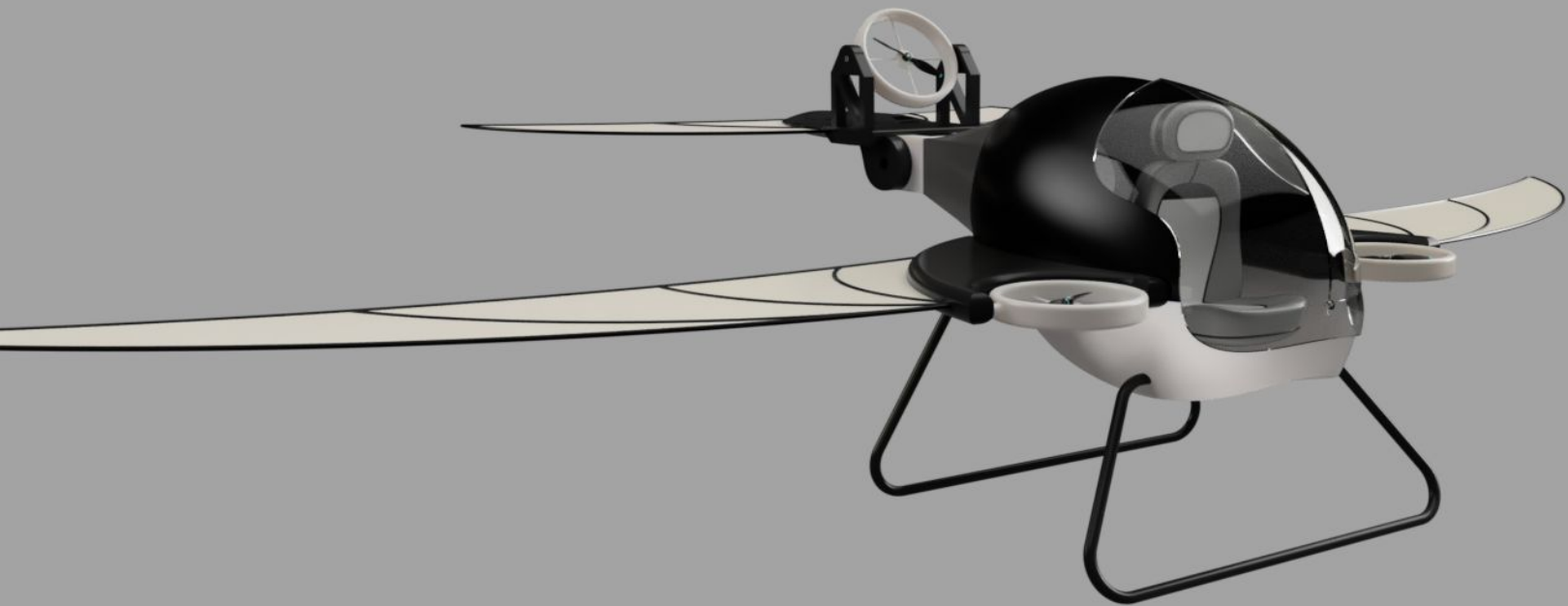

✦ 05 ✦

**FUNCIONAMIENTO**

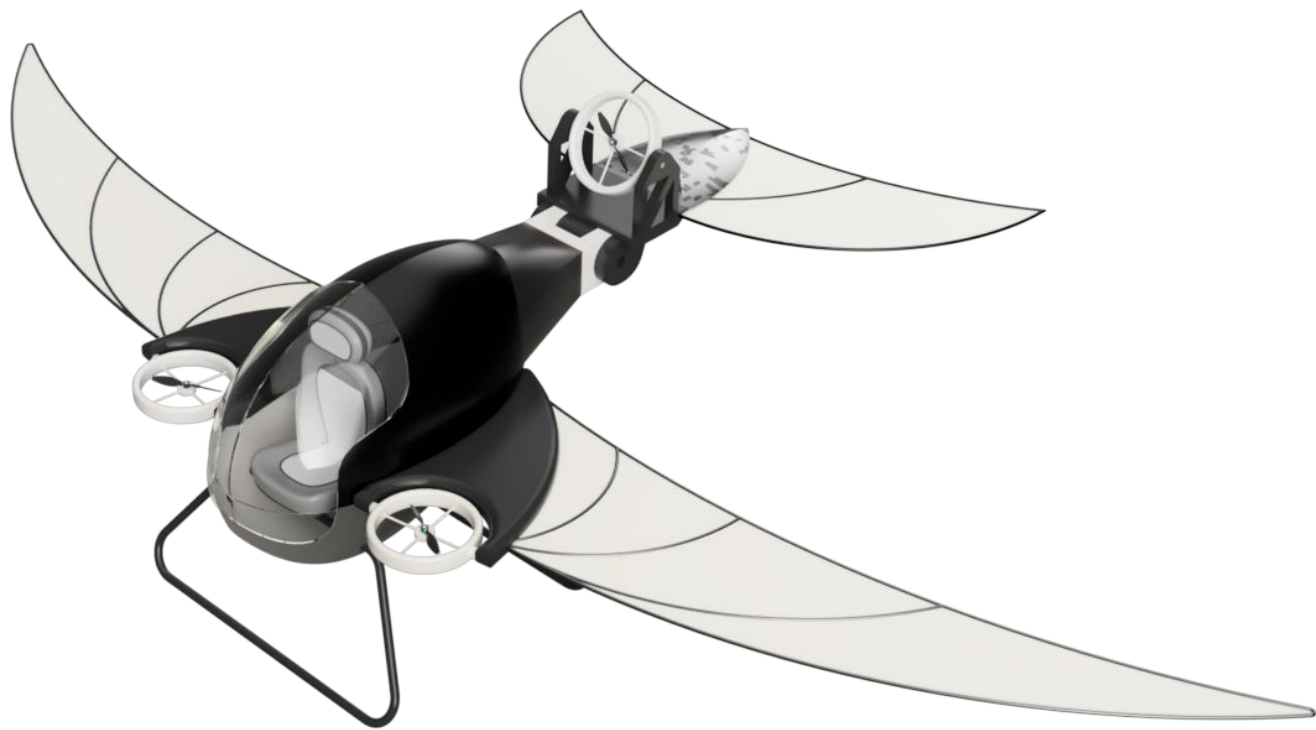

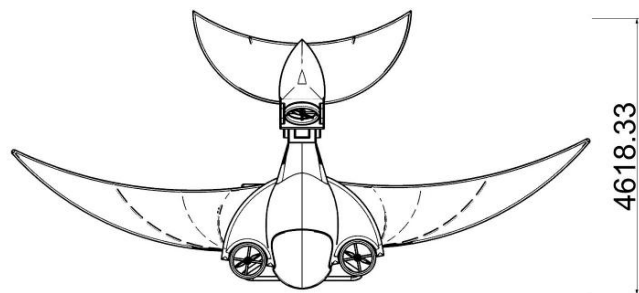

4618.33

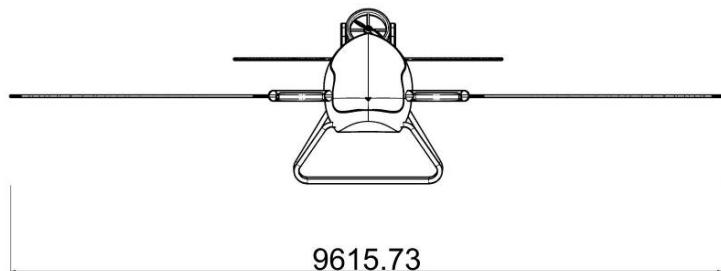
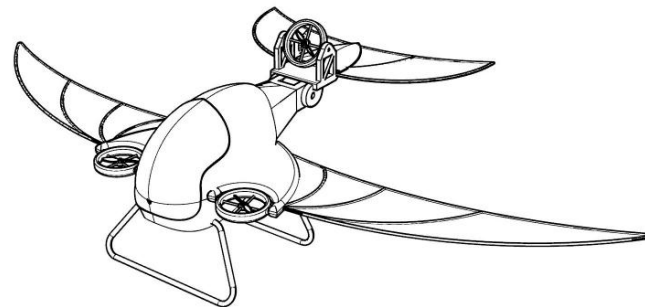

9615.73

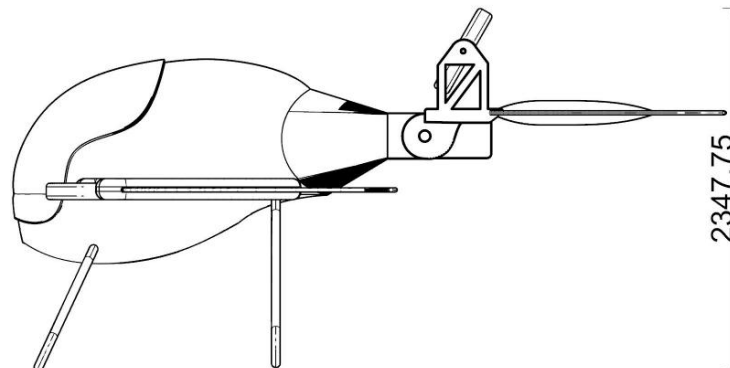

2347.75

