

# M3 Sonar<sup>®</sup> HF

## with synchronization and 1PPS



KONGSBERG



## Multimode multibeam sonar

### 922-2030000

Kongsberg Discovery's M3 Sonar HF is a multibeam system with both imaging and profiling capabilities. The M3 Sonar HF provides high-resolution and easy-to-interpret images by combining the rapid refresh rate of a conventional multibeam sonar with image quality comparable to a single-beam sonar.

#### Don't miss a thing

Detection of small objects out to 100 meters combined with up to a 140° field of view allows the operator to see the complete underwater picture in real-time. The M3 Sonar HF provides high-resolution images at short range, reducing the time it takes to search for and locate targets.

#### Multiple installation options

The M3 Sonar HF is suitable for a wide range of vehicles from ROVs to USVs and ASVs. When using a surface vessel, you can easily deploy the M3 Sonar HF on a pole mount. This sonar can also be tripod mounted.

#### User-friendly software

The operating software was developed specifically for the M3 Sonar HF to manage communications with the head and operate all beamforming and image processing.

The predefined imaging modes present distortion-free images at a high update rate. For an alternative data visualization, the provided profiling modes generate a 3D point cloud.

#### FEATURES

- Up to 4000 m water depth
- Imaging and profiling capabilities
- 700 kHz to 1400 kHz operating frequency
- GeoTIFF output for image mosaics
- Intuitive and easy-to-use software
- Significant time savings
- Integrated tilt and pan/tilt control

#### APPLICATIONS

- Pipeline survey and inspection
- Fish behaviour monitoring
- Fish habitat mapping
- Infrastructure inspection
- Dredge monitoring
- Cable laying and trenching

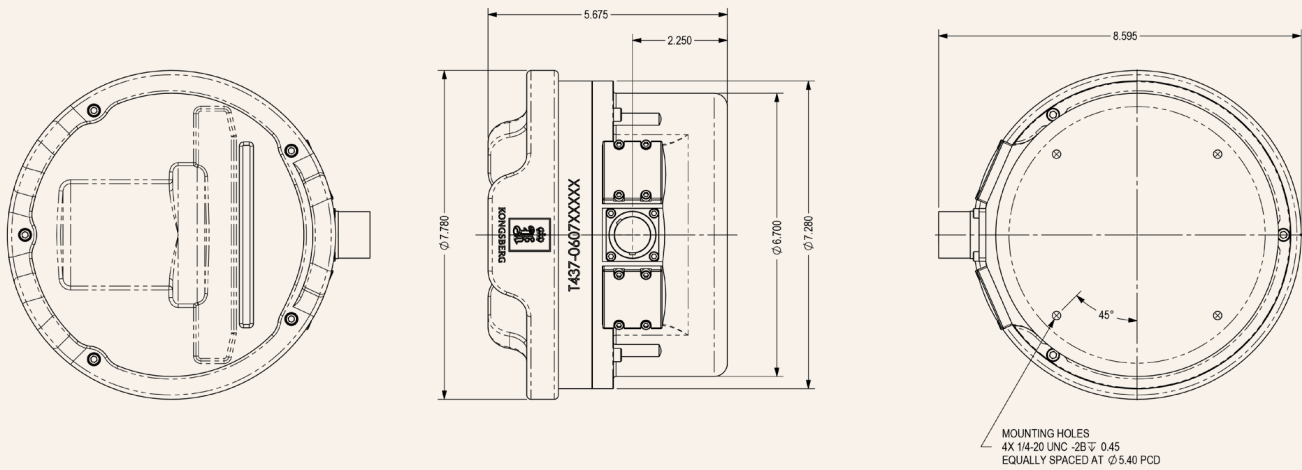

# Technical specifications

M3 Sonar® 922-20300000

## Sonar Specifications

Range	0.2 m to 100 m
Range resolution	1 cm
Frequency	700 kHz - 1400 kHz
Pulse types	CW, CHIRP
Update rate	up to 40 Hz*
Max. number of beams	512

## 700-khz modes

Detection range / Nadir depth	100 m*
Coverage	140°
Beamwidth	1.0° x 30°
Ping rate	30 Hz*
(maximum, range dependant)	

## 950-khz modes

Detection range / Nadir depth	90 m*
Coverage	140°
Beamwidth	0.8° x 27°
Ping rate	30 Hz*
(maximum, range dependant)	

## 1200-khz modes

Detection range / Nadir depth	50 m*
Coverage	75°
Beamwidth	0.65° x 21°
Ping rate	30 Hz*
(maximum, range dependant)	

## Imaging

Detection range / Nadir depth	100 m*
Coverage	140°
Beamwidth	1.0° x 30°
Ping rate	30 Hz*

## Imaging

Detection range / Nadir depth	90 m*
Coverage	140°
Beamwidth	0.8° x 27°
Ping rate	30 Hz*

## Imaging

Detection range / Nadir depth	50 m*
Coverage	75°
Beamwidth	0.65° x 21°
Ping rate	30 Hz*

## Bathymetry

Detection range / Nadir depth	50 m*
Coverage	140°
Beamwidth	1.0° x 1.8°
Ping rate	35 Hz*

## Bathymetry

Detection range / Nadir depth	40 m*
Coverage	140°
Beamwidth	0.8° x 1.4°
Ping rate	35 Hz*

## Bathymetry

Detection range / Nadir depth	20 m*
Coverage	75°
Beamwidth	0.65° x 11°
Ping rate	35 Hz*

## 1400-khz modes

Detection range / Nadir depth	30 m*
Coverage	45°
Beamwidth	0.55° x 18°
Ping rate	30 Hz*
(maximum, range dependant)	

## Interface Specifications

Communication	Ethernet
Data rates	10/100 Mbps
Input voltage	12 to 36 VDC
Input power	50 W (avg.), peak power < 70 W, mode dependant
Operating system	Windows 11
Synchronization	PRI Sync, 1PPS

## Environmental Specifications

Operating temperature	-4°C to +38°C
Storage temperature	-40°C to +55°C

## Mechanical Specifications

Width	218 mm (8.59 in)
Height	144 mm (5.67 in)
Weight in air	7.8 kg (17.3 lbs)
Weight in seawater	5.0 kg (11.0 lbs)
Depth rating	4000 m
Connector type	SEACON®
Connector model	MINK-10-FCRL
Materials	Titanium, Stainless Steel, Elastomeric Polyurethane

\* Specifications under ideal conditions.

Specifications subject to change without any further notice.