

PARTS LIST

ITEM	QTY	DESCRIPTION
1	1	XL1.0 SWIVEL MODULE ASSY
2	1	SEAL BLOCK, PTFE
3	2	PRODUCT SEAL O-RING
4	2	XL1.0 SWIVEL FLANGE
5	2	SCH 40 RF WN FLANGE

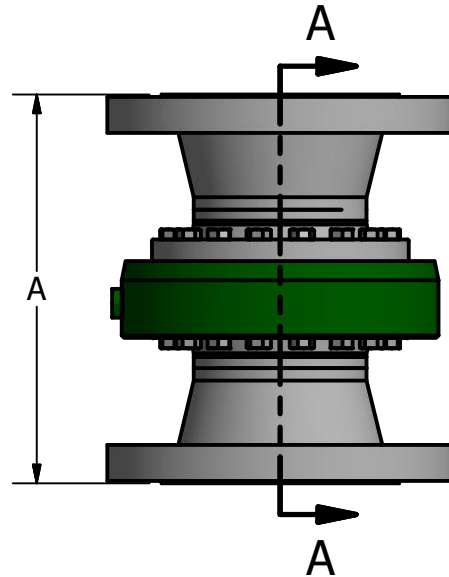
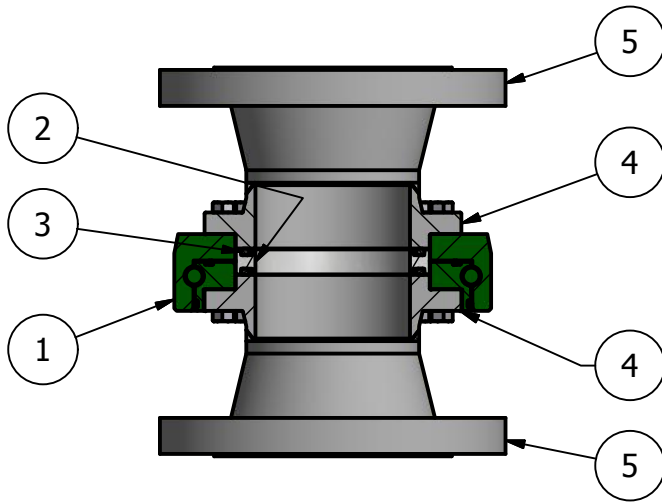
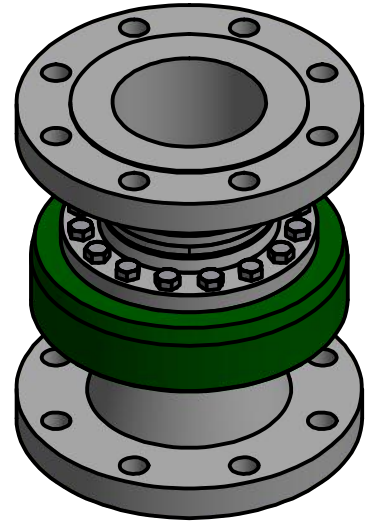

SECTION A-A
SCALE 1 / 5

WETTED MATERIALS:

- CARBON STEEL
- 316L STAINLESS STEEL
- 304L STAINLESS STEEL
- OTHERS BY REQUEST

SEAL MATERIAL:

- BUNA
- VITON
- FEP
- EPDM

PART NUMBER	SIZE	A	BCD	H (QTY)	CONN TYPE
S20XL1.02 __ 15X15	2"	9 1/8	4 3/4	3/4 (4)	150 #
S20XL1.02 __ 30X30	2"	9 5/8	5	3/4 (4)	300 #
S20XL1.03 __ 15X15	3"	9 5/8	6	3/4 (4)	150 #
S20XL1.03 __ 30X30	3"	10 3/8	6 5/8	7/8 (8)	300 #
S20XL1.04 __ 15X15	4"	10 1/8	7 1/2	3/4 (8)	150 #
S20XL1.04 __ 30X30	4"	10 7/8	7 7/8	7/8 (8)	300#

STYLE 20 FLANGED
XL1.0 SWIVEL

