



Monroe Fire Protection District



Board of Trustees

Meeting Agenda

April 8, 2026

Meeting held at Station 25

5081 N. Old State Rd 37 and via

ZOOM

at 6:00 PM EST

Meeting Link: <https://us02web.zoom.us/j/2509924795>

Board appointed by Monroe County Commissioners

Vicky Sorensen
2026-2030

Mark Kruzan
2025-2028

Michael Baker
2026-2030

John Bernstein
2026-2030

Susan Hingle
2025-2028

Kevin R. Robling
2026-2030

Daniel Vest
2025-2028

- 1. Call to Order and Roll Call**
- 2. Changes or Amendments to Agenda**
- 3. Public Comment**
- 4. Approval of Minutes – March**
- 5. Department Updates**
 - a. Legal Counsel – Attorney, Christine Bartlett
 - b. Statistics – Deputy Chief, Matt Bright
 - c. Operations and EMS – Deputy Chief, Matt Bright
 - d. Fleet – Fleet Manager, Nick Powell
 - e. Facilities & Logistics – Deputy Chief, Bill Tusing
 - f. Training – Assistant Chief, Danny Gillespie
 - g. Community Risk Reduction – Deputy Chief, Steve Coover
 - h. Financial – Financial A.A., Lorie Robinson
 - i. Administrative – Chief, Dustin Dillard
- 6. Unfinished Business**
 - a. AFG Grant – exhaust removal systems
- 7. New Business**
 - a. Hiring
 - b. Gear Purchase
 - c. Generator Purchase – Station 26
 - d. Investment Option
 - e. Engine Purchase
 - f. Mower Purchase
- 8. Financials**
 - a. Financial – Claims
 - b. Financial – Payroll
 - c. Financial – Statement
- 9. Next Meeting Scheduled May 13, 2026 at Station 21, 9094 S Strain Ridge Road beginning at 6pm**
- 10. Adjourn**



Monroe Fire Protection District



MINUTES OF MEETING OF THE BOARD OF TRUSTEES

Chair Vicky Sorensen called the meeting of the Board of Trustees of the Monroe Fire Protection District to order at 6:00p.m. EST Wednesday, March 11, 2026. The meeting was held in person at Station 21, located at 9094 S Strain Ridge Rd, Bloomington, Indiana and via Zoom for public to view. Public notice of the meeting had been duly made to local media by email transmission and hard copy notices had been placed in all the usual places.

Administrative Assistant Tammy Bovenschen called the roll of the board of trustees to determine members present, absent, and to identify others present via Zoom.

Present in person were as follows:

- Vicky Sorensen, Chair
- Michael Baker, Fiscal Officer
- John Bernstein, Trustee
- Susan Hingle, Trustee (arrived at 6:06pm)
- Kevin R. Robling, Trustee
- Dan Vest, Trustee
- Mark Kruzan, Vice-Chair (via Zoom)

Those absent were as follows:

- Steve Coover, Deputy Chief, Community Risk Reduction

Others present were as follows:

- Dustin Dillard, Chief
- Jeffrey Combs, Deputy Chief of Administration
- Bill Tusing, Deputy Chief of Logistics
- Matt Bright, Deputy Chief, EMS & Operations
- Danny Gillespie, Assistant Chief of Training
- Christine Bartlett, Attorney, Ferguson Law
- Nick Powell, Fleet Manager
- Tammy Bovenschen, Administrative Assistant
- Lorie Robinson, Financial Assistant
- Darrell Cooper, IT Specialist
- Jason Allen, Battalion Chief

**HEADQUARTERS
3953 S KENNEDY DRIVE
BLOOMINGTON IN
812-331-1906
812-336-1166 (FAX)**

CHANGES OR AMENDMENTS TO THE AGENDA

Chair Vicky Sorensen asked if there were any changes or amendments to the agenda. Administrative Assistant Tammy Bovenschen stated no changes or amendments.

PUBLIC COMMENT

Chair Vicky Sorensen explained this was the time when any member of the public could speak to the board concerning any matter not listed on the agenda. No public comment.

MINUTES OF PREVIOUS MEETING

Minutes from February were presented to the board for approval.

Trustee Kevin Robling made a motion to approve the minutes.

Trustee John Bernstein 2nd

Bernstein – Yes, Baker – Yes, Sorensen – Yes, Kruzan – Yes, Vest – Yes, Robling – Yes

Motion passed 6-0

DEPARTMENT UPDATES

Department Updates

a. Legal Updates

Legal Counsel, Christine Bartlett stated the district has kept us busy with background checks. Working through procedures and processes for procurement that's coming up with Federal Grant dollars. Legislature session – Senate Bill 270. Shouldn't have direct impact on Fire District. DLGF will be sending out a test.

Chair Vicky Sorensen asked about our board if townships consolidate. Legal Counsel Christina Bartlett explained that since none of this goes into effect this year hopefully those details can be looked at and updated.

b. Statistics

Deputy Chief Matt Bright updated the board the monthly statistics for January.

TOTAL Emergency Calls	364
Fire Calls	20
Hazardous Situation	21
Medical	203
Public Service	53
Rescue	7
No Emergency	58
Law Enforcement	2
Incidents by District Station	364
Station 21	35
Station 22/HQ	106
Station 23	11

Station 24	20
Station 25	23
Station 26	14
Station 29	132
Station 39	20
Aid in support of primary entity	28
Aid given	14
Aid received	10
Aid in lieu of primary entity	
Aid given	3
Aid acting as another entity	
Aid given	1
Ambulance 21	2
Ambulance 22	6
Ambulance 23	3
Ambulance 29	52
Total Patient Transports	63
IU Health Bloomington	18
Monroe Hospital	2

Deputy Chief Matt Bright elaborated on the Statistical Summary indicating the turnout and response times. We have 300 plus square miles – would be considered urban and rural and the response time would be computed at 80% based on NFPA standards. Unusual scenes (no emergency) – Chief will automatically adjust the dispatch time to reflect when the responding chief was actually notified.

Chief Dustin Dillard explained the new data and system – 90% means 90% of the time we were in the range.

Susan Hingle mentioned how beneficial it was meeting with Deputy Chief Bright to get a better understanding.

Trustee Kevin Robling commented that he liked looking at the full report. Was this due to the new software? Deputy Chief Matt Bright explained that he believes he's given similar information, and the new national system doesn't give us the same results. NFRIS was only for fire whereas NERIS is all emergencies. Trustee Robling will schedule a meeting with Deputy Bright to discuss further.

Trustee John Bernstein asked what the different icons mean on the MFD Incident Map – 1/1/2026 NERIS. Deputy Chief Matt Bright said he's unsure what the icons mean, but he'll find out and report back.

c. Emergency Medical Services & Operations

Deputy Chief Matt Bright updated the board on EMS & Operations

Current Situation:

- Data uploads and set up for First Due Software – the process continues
 - Current focus on training and assets (apparatus checks, work orders)

Accomplishments:

- Tornado response on 2/19 – successful mitigation, rapid assessment for injuries and damage assessment, quick callback response
- Received our BLS service provider recertification, and sent information to billing
- Presented at Emergency Preparedness Meeting along with BC Liff

Planned Activities:

- Conclude all first due module set-ups

d. Fleet

Fleet Manager Nick Powell updated the board on Fleet:

Current Situation:

- Maintenance:
 - 14 minor
 - 3 moderate
 - 1 major
 - 2 out of service for 1+days
 - Rescue 22 – oil leak and hydraulic tray failed to support power unit
 - Ambulance 21 – Horn continues to honk
- Marine Units
 - Currently cycling marine units through for spring services

Accomplishments:

- Met with Fire Service Inc
 - Follow up meeting with Fire Services Inc. Engine 22 was available for them to inspect ongoing issues. They were able to observe numerous issues in person. Issues included: roll up door issues, cab lift and electrical issues. Awaiting to schedule and pick up time for repairs
- In stock parts
 - Provided commercial part numbers to a local vendor. The vendor will now keep a supply of parts that used to require a trip to Indianapolis. The cost of parts is also competitive to the Indianapolis commercial parts price. This information has also been provided to Bloomington City.
- UTV Spring Service
 - UTV 21, 22, 25, 39 all serviced. UTV 24 service supplies have been received

- Annual Apparatus and Equipment services and testing
 - Obtained quotes for: pump test, service and truck service, ladder test, hose test, TNT extrication tool service, Genesis extrication tool service, VFDS Annual Aerial Inspections

Planned Activities:

- Schedule Annual Service
 - Hose, ladder, extrication, pump, and aerial services and testing
- Marine Unit Service Completion
 - Service and test all marine units
- Meet with Fire Service – 3rd meeting
 - Follow up meeting with Fire Service to address Engine 22 issues

Trustee John Bernstein asked if the amount shown for warranty work is what we have to pay or is that just showing the cost. Fleet Manager Nick Powell indicated the cost is what the warranty pays.

Trustee John Bernstein asked who does large equipment alignment? Fleet Manager Nick Powell stated it could be either Crossroads in Bedford or Sternberg International Truck Sales & Service located off Dillman Rd.

e. Facilities & Logistics

Deputy Chief Bill Tusing updated the board on Facilities & Logistics:

Current Situation:

- Getting Bids for generator Station 26
- Continue with repairs from building settling at Station 25
- Getting estimates for electrical issue at Station 21

Accomplishments:

- Water lines moved from attic at Station 29 to eliminate freezing issue
- Updated to LED exterior lights at Station 25 and 29
- Replaced damaged ceiling tile in Station 21 radio room

Planned Activities:

- Blow in installation at Station 23
- Replace downstairs entry door at HQ Annex
- Get bids on mower replacement for Station 21

Trustee Kevin Robling asked about the replacement garage door at Station 29. Deputy Chief Bill Tusing explained that someone backed the truck too close to it.

f. Training

Assistant Chief Danny Gillespie updated the board on Training:

Current Situation:

- Vehicle Extrication day for Volunteers/Substitutes

- We will hold a training specifically for Volunteers/Substitutes on March 25th at Station 29
- Officer Development Training (#19) at Station 21
- Working with Lamar (Billboard company) to choose a site location for upcoming rope rescue training

Accomplishments:

- Ordered and received 4-pack of AED Trainers for CPR course
- CPR manikins and AED trainers cleaned and stored
- Worked with Menards to purchase drywall at discounted rate due to storm damage. Delivered approximately 360 sheets to Station 25 for use in training

Planned Activities:

- Working with District 8 on approval of District funded courses for fall/Winter 2026
- Working with Cpt. Fisher to develop next HazMat quarterly training – explosives
- Continue working with Hoosier Hills and Ivy Tech to provide training resources

Training Hours:

- Company Training
 - January training hours – 2,036
 - February training hours – 2,104

Trustee Susan Hingle asked how do you train with drywall? Assistant Chief Danny Gillespie explained that salvage and overhaul. Once a fire is put out, we're looking for fire that's hidden behind the walls up in the ceiling. In the training tower, we have an open spot in the ceiling that we can put drywall up onto. When we go and put a fire out, crews can go along with pip poles and pull that drywall down. Applying fire on top of that drywall will provide a heat signature – thermal imaging camera will help look for those heat signatures. Teaches crews how to punch through walls to evacuate as needed.

g. Community Risk Reduction

Deputy Chief Jeffrey Combs updated the board on Community Risk Reduction.

Current Situation:

- Update CPR presentation to 2025 program
 - Two classes to be given in March as Beta tests
- Research 3D scanner for fire investigations and other applications

Accomplishments:

- Attended autopsy for third fatality related to Anderson Road fire and fatality Old SR 37
 - Provided background to pathologist regarding events
- Provided information and support to Anderson Road family

- Attended Supporting Youth through Suicide Prevention and Postvention training

Planned Activities:

- Breakfast with the Bunny March 28th
- CERT Class March 26 – April 18
- City Hall Display case program for April 2026

Fire Inspections:

- Fire Safety Inspections – 38
- Re-Inspections – 4
- New Construction Inspections – 1
- Plans Review – 2
- Consultations – 11

Trustee John Bernstein asked about tornado cleanup. Deputy Chief Jeffrey Combs explained Van Buran Township organized the cleanup and our personnel helped. Over 200 people probably helped.

Statistical Update from previous question during the meeting: Chief Dustin Dillard commented that he went back and pulled the stats from December and a couple things were missing – day of the week, time of the day, shifts, and by station no graph. Incidental count by and type given was a half-page previously because it specifically indicated departments, we were giving aid to and getting aid from. On ambulance data, we are missing how many transports, we just have total number down unless the total number is the transports. On the turnout time, that was its own half page previously because each station was listed. We were not reporting on travel time. Total response time was also half a page because again each station was listed. There are several data points that are missing, and we can get that sorted out for next meeting.

Chair Vicky Sorensen explained with any new system we all have to adapt and get used to.

h. Financial – Claims

Financial Assistant Lorie Robinson presented financial summary for February 2026.

Current Situation:

- GAAP Report submission requests being received and created for submission
- FORVIS GAAP audit sample requests being received and created for submission

Accomplishments:

- Annual financial report prepared and submitted as presented in the financial board folder
- Submitted the Gateway Contract Attestation report and verified Polk and Salt

- townships had uploaded fire protection service agreements
- Completed and submitted the US Census Bureau Annual Survey of Local Government Finances
- Received and posted the February Local Income Tax (LIT) Revenue \$980,971.66

Planned Activities:

- Participate in the Batchelor Middle School Reality Store on March 13 representing MFPD
- Continuing to work through the GAAP submission and audit processes

EMS Revenue & Collections:

- Added the active accounts receivable – February
- General Summary – 14.9%
 - Encumbrances approved in February not correctly done by accountant
- Cumulative Fund – 33%

Trustee Kevin Robling asked about COBRA and who will pay? Financial Assistant Lorie Robinson explained that the district must pay a COBRA Administrator. If a full-time employee that has health benefits leaves the district, they can continue with our medical insurance (paying what we pay), plus a 2% fee on top of that. Once they leave, a COBRA Administrator will send us paperwork that must meet certain deadlines for timing. The district pays a small fee to have a COBRA Administrator assist with backend steps.

Trustee Kevin Robling asked about the 18-month review with Peoples State Bank – do you network with other folks? Financial Assistant Lorie Robinson stated she checked with State Board of Accounts, and we can purchase CD's – certificate of deposit. With that, we could purchase a 6-month or 13-month CD at this time with the current bank we use at Peoples State Bank. For 6 months, it would net us about \$11,000.00 more. For 13 months, it would net us about \$19,000.00 more. Very little risk because it's considered cash on hand. We're not going to lose any money, just how much interest can we make while it sits there. We would check for competitive offers from all banks as well.

Trustee Kevin Robling stated the Rainy-Day Fund should be in CD's.

Trustee Dan Vest asked what the penalty would be for early withdrawal. Financial Assistant Lorie Robinson stated no principal lost, only lost interest.

Chair Vicky Sorensen asked if State Board of Accounts say that we have to keep a certain amount in Rainy-Day? Financial Assistant Lorie Robinson explained it can't be appropriated or committed within the timeframe that you put it in.

Trustee John Bernstein stated it seems logical to keep some of the money aside and put some in a short investment and the other in long, so you're hedging your bets.

Trustee Kevin Robling asked if Financial Assistant Lorie Robinson could come to the Board with proposals for CD's at next meeting or the following.

Chair Vicky Sorensen asked if you take everything out of Rainy-Day, is that okay with State Board of Accounts? Financial Assistant Lorie Robinson explained that yes if we buy CD's it's still listed as cash on hand.

Deputy Chief Matt Bright asked if we've looked at the State Investment Pool? Financial Assistant Lorie Robinson explained lots of administrative fees associated with it, but she'll check it out.

Chair Vicky Sorensen asked about the Contractual Services, is that usually for three months? Financial Assistant Lorie Robinson explained we have made our yearly payment for First Due.

i. Administrative Report

Deputy Chief Jeffrey Combs updated the board Administrative Report.

Current Situation:

- Continuing updates to senior chief job descriptions based on 2026 organizational changes to increase efficiency
- Working on 2026 Run Cards and EMS Updates with Monroe County Dispatch
- Continue to monitor house and senate bills with potential impact to the fire district

Accomplishments:

- 2026 Hiring Process – application reviews and interviews completed
- Responded to February 19th Tornado and are reviewing data collected in Quick Capture
- Attended 2 courses hosted by the International Fire Chief's Association with union and volunteer representatives

Planned Activities:

- Monroe County Dispatch Policy Board Meeting
- Work with Monroe County EMA on Tornado data and disaster response reimbursement request
- Beginning planning meetings for additional townships joining the District

Personnel Report:

- New Hires – Full Time – 0
- New Hires – Part-Time – 0
- New Hires – Substitutes – 5
- Retirements – 2
- Promotions – 0
- Resignations – 0

Volunteer Hours February: 99.5

Chief Dustin Dillard mentioned severe weather preparedness and MFPD did the statewide tornado alarm. This year, we weren't invited to check the actual tornado sirens; however, we have been informed that several had significant issues. We're compiling a list to communicate with the EMA director.

Trustee Kevin Robling asked about Van Buren Township Trustee Rita Barrow, what are we working on with her? Deputy Chief Jeffrey Combs explained that we're working on Capital Improvement – fund projects for the District. Rescue equipment, \$90,500 which allows us to allocate resources with new equipment and then move that throughout the district to share the wealth. Also, cardiac monitors for Van Buren township and we'll take the monitors we have to other areas to cover the district. She's also willing to purchase a Fire Truck – 1.5 million of funds that she's going to support the fire district with as part of her Capital Improvement plan.

Trustee Kevin Robling asked if that's common with other townships? Deputy Chief Jeffrey Combs explained that it's highly common with Benton Township Trustee did something similar at lower scale and less money. Bloomington Township funded Capital Improvement Plan for stoplights and radio upgrades at the Bloomington Township stations.

Trustee Kevin Robling asked do we go to them, or do they come to us? Deputy Chief Jeffrey Combs stated that Van Buren and Benton came to us.

Trustee John Bernstein asked about the stoplights that were funded by Bloomington Township, are you referring to right outside of the stations? Deputy Chief Jeffrey Combs stated no, we're referring to the lights outside of the bay doors, so people don't run into the garage. Some of our buildings are extremely old, garage doors aren't as tall.

UNFINISHED BUSINESS

a. Zoll Monitors

Deputy Chief Matt Bright presents the purchase request of Zoll Monitors to the Board. Several quotes in the packet. This expense will come from the Benton Township Capital Improvement funds donated to the District. Refurbished monitors as opposed to new. They still come with a warranty, and they will service them.

Trustee Kevin Robling made a motion to approve purchase of Zoll Monitors for a total of \$126,853.50.

Trustee John Bernstein 2nd
Motion Passed 7-0

NEW BUSINESS

a. Cash Transfer

Financial Assistant Lorie Robinson explained the correction to transfer cash from Special Fire Cumulative Fund to the General Fund. \$3,000 to cumulative fund, \$3,000

to general; however, the entire amount was deposited into the cumulative fund in December 2025.

Trustee Kevin Robling made a motion to approve the correction transfer from Cumulative Fund to General Fund.

Trustee Kevin Robling 2nd

Bernstein – Yes, Baker – Yes, Sorensen – Yes, Kruzan – Yes, Vest – Yes, Robling – Yes, Hingle – Yes

Motion Passed 7-0

b. Annual Fleet Equipment Testing

Fleet Manager Nick Powell presented the Annual Fleet Equipment Testing to the Board. Starting with Aerial Safety Inspections, this is for ladder trucks only. Only able to obtain one quote for this – CFS Inspections for a total cost of \$3,010.00.

Trustee Kevin Robling made a motion to approve the CFS Inspection for a total of \$3,010.00.

Fiscal Officer Michael Baker 2nd

Bernstein – Yes, Baker – Yes, Sorensen – Yes, Kruzan – Yes, Vest – Yes, Robling – Yes, Hingle – Yes

Motion Passed 7-0

Fleet Manager Nick Powell presented the Hose Testing and Inventory through Nichol's Fire and Fleet for a total of \$11,814.75. Fleet Manager Powell expressed that he received other quotes but recommends Nichol's Fire and Fleet keep a pretty good inventory of our hose and good pricing.

Trustee John Bernstein asked if any other bids were competitive? Fleet Manager Nick Powell stated yes, one being \$50 more. Nothing was way out of line.

Trustee Kevin Robling made a motion to approve \$11,814.75 for Hose Testing and Inventory through Nichol's Fire and Fleet.

Fiscal Officer Michael Baker 2nd

Bernstein – Yes, Baker – Yes, Sorensen – Yes, Kruzan – Yes, Vest – Yes, Robling – Yes, Hingle – Yes

Motion Passed 7-0

Fleet Manager Nick Powell presented the Ground Ladder Testing with Heritage Fire Equipment to the Board for a total of \$4,116.00.

Trustee Susan Hingle asked if we've used Heritage Fire for other things? Deputy Chief Jeffrey Combs stated we have not, but Bean Blossom Township has.

Trustee Kevin Robling asked about these requests when it comes to the budget. Chief Dustin Dillard and Deputy Chief Jeffrey Combs state that we factor in all these requests every year into the budget. This isn't new money – it comes out of the same budget.

Trustee John Bernstein made a motion to approve the Ground Ladder Testing with Heritage Fire Equipment for a total of \$4,116.00.

Trustee Susan Hingle 2nd

Bernstein – Yes, Baker – Yes, Sorensen – Yes, Kruzan – Yes, Vest – Yes, Robling – Yes, Hingle – Yes

Motion Passed 7-0

Fleet Manager Nick Powell presented the Pump Test, Pump Service, Truck Service, DOT Inspection all with Nichol's Fire and Fleet for a total of \$16,952.06. Fleet Manager Powell explains that pump tests are required, while we're doing pump test, we have them do pump service and truck service. DOT Inspection is something that Fleet Manager Powell recommends this year for an additional \$50.00 per truck, check the tires, brake measurements, and air leaks. Ensure good feedback, good health of the trucks, and documentation.

Trustee Kevin Robling made a motion to approve Pump Test, Pump Service, Truck Service, DOT Inspection all with Nichol's Fire and Fleet for a total of \$16,952.06

Trustee Susan Hingle 2nd

Bernstein – Yes, Baker – Yes, Sorensen – Yes, Kruzan – Yes, Vest – Yes, Robling – Yes, Hingle – Yes

Motion Passed 7-0

Fleet Manager Nick Powell presented the TNT Tool Service to the Board with Hoosier Fire for a total of \$2,575.00.

Fiscal Officer Michael Baker made a motion to approve TNT Tool Service with Hoosier Fire for a total of \$2,575.00.

Trustee Kevin Robling 2nd

Bernstein – Yes, Baker – Yes, Sorensen – Yes, Kruzan – Yes, Vest – Yes, Robling – Yes, Hingle – Yes

Motion Passed 7-0

Fleet Manager Nick Powell presented the Genesis Tool Service with Howell Rescue Systems to the Board for a total of \$2,500.00.

Fiscal Officer Michael Baker made a motion to approve Genesis Tool Service with Howell Rescue Systems for a total of \$2,500.00.

Trustee Kevin Robling 2nd

Bernstein – Yes, Baker – Yes, Sorensen – Yes, Kruzan – Yes, Vest – Yes, Robling – Yes, Hingle – Yes

Motion Passed 7-0

Fleet Manager Nick Powell shares the updated total for all services and inspections to the Board - \$40,967.81.

FINANCIALS

a. Financial – Claims

Financial Assistant Lorie Robinson presented claims February 2026. Total claims - \$288,481.75.

Trustee Kevin Robling made a motion to approve the claims for February 2026.

Fiscal Officer Michael Baker 2nd

Bernstein – Yes, Baker – Yes, Sorensen – Yes, Kruzan – Yes, Vest – Yes, Robling – Yes, Hingle – Yes

Motion Passed 7-0

b. Payroll

Administrative Assistant Tammy Bovenschen presented the February monthly payrolls for approval on 15th and 28th

- February 15th payroll – totaling \$329,511.80
- February 28th payroll – totaling \$285,290.20
 - 28 Day

Trustee Kevin Robling made a motion to approve the payrolls for February as presented.

Fiscal Officer Michael Baker 2nd

Bernstein – Yes, Baker – Yes, Sorensen – Yes, Kruzan – Yes, Vest – Yes, Robling – Yes, Hingle – Yes

Motion Passed 7-0

c. Financial – Statement

Financial Assistant Lorie Robinson presented the financial statement to the board for February approval.

Trustee Kevin Robling made a motion to approve the financial statement for February.

Fiscal Officer Michael Baker 2nd

Bernstein – Yes, Baker – Yes, Sorensen – Yes, Kruzan – Yes, Vest – Yes, Robling – Yes, Hingle – Yes

Motion Passed 7-0

ADDITIONAL COMMENTS

Happy Birthday to Kevin Robling Saturday, 3/14.

Fiscal Officer Michael Baker mentioned that Financial Assistant Lorie Robinson contacted him directly when she realized the error made regarding the cash transfers for the Cumulative Fund and General Fund. Special shout-out to Lorie for following that through.

NEXT MEETING

Chair Vicky Sorensen stated that the next meeting will be in person April 8, 2026, at Station 25, located at 5081 N Old State Road 37 Bloomington, Indiana. The meeting will also be held via zoom.

ADJOURN

Trustee Kevin Robling made a motion to adjourn at 7:34p.m.

Minutes approved by the board of trustees on April 8, 2026:

Aye:

Nye:

Vicky Sorensen, Chair

Vicky Sorensen, Chair

Mark, Kruzan, Vice-Chair

Mark Kruzan, Vice-Chair

Michael Baker, Fiscal Officer

Michael Baker, Fiscal Officer

John Bernstein, Trustee

John Bernstein, Trustee

Susan Hingle, Trustee

Susan Hingle, Trustee

Kevin R. Robling, Trustee

Kevin R. Robling, Trustee

Dan Vest, Trustee

Dan Vest, Trustee

Copy furnished:

- Mrs. Vicky Sorensen, Chair
- Mr. Michael Baker, Fiscal Officer
- Ms. Susan Hingle, Trustee
- Mr. Daniel Vest, Trustee
- Mr. David Ferguson, Legal Counsel

- Mr. Mark Kruzan, Vice-Chair
- Mr. John Bernstein, Trustee
- Mr. Kevin R. Robling, Trustee
- Mr. Dustin Dillard, Fire Chief
- Mrs. Christine Bartlett, Legal Counsel

Headquarters, Bulletin Board
Station No. 22, Bulletin Board
Station No. 24, Bulletin Board
Station No. 26, Bulletin Board
Station No. 39, Bulletin Board

Station No. 21, Bulletin Board
Station No. 23, Bulletin Board
Station No. 25, Bulletin Board
Station No. 29, Bulletin Board

Monroe Fire Protection District

Statistical Summary

March 1-31, 2026



INCIDENTS BY CATEGORY:	COUNT:	%
Fire	35	7.63%
Hazardous Situation	26	5.66%
Medical	278	60.57%
Public Service	49	10.68%
Rescue	7	1.53%
No Emergency	63	13.73%
Law Enforcement Support	1	0.22%
TOTAL	459	
	2025	512

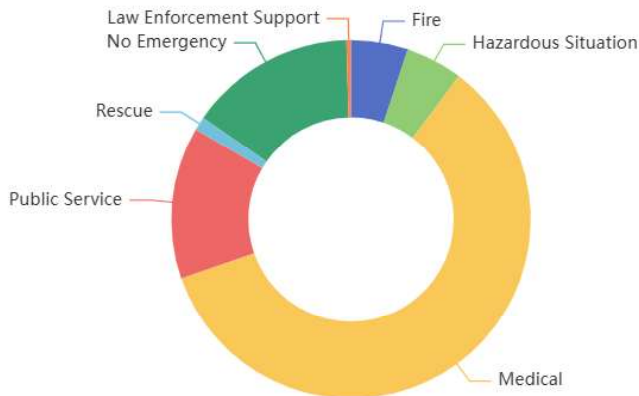

INCIDENTS BY DISTRICT STATION

Station 21	47
Station 22 / HQ	102
Station 23	6
Station 24	31
Station 25	54
Station 26	22
Station 29	169
Station 39	28
TOTAL	459

Incident Count by Aid Type and Direction

Aid in support of primary entity		
<i>Aid Given</i>	48	60.26%
<i>Aid Received</i>	11	14.10%
Aid in lieu of primary entity		
<i>Aid Given</i>	16	20.51%
<i>Aid Received</i>	1	1.28%
Aid acting as another entity		
<i>Aid Received</i>	3	3.80%
TOTAL	79	

INCIDENTS AID GIVEN

Bean Blossom	5
Bloomington (City)	38
Ellettsville	18
Greene County	6
Lawrence County	0
Brown County	0
Owen County	0
Morgan County	0
TOTAL	67

MFD Ambulance Transports

Destination	Total	% of Total
IU Health Bloomington Hospital	47	94.00%
Monroe Hospital	3	6.00%
Total	50	

Responses	
Ambulance 21	5
Ambulance 22	8
Ambulance 25	5
Ambulance 29	63
	81

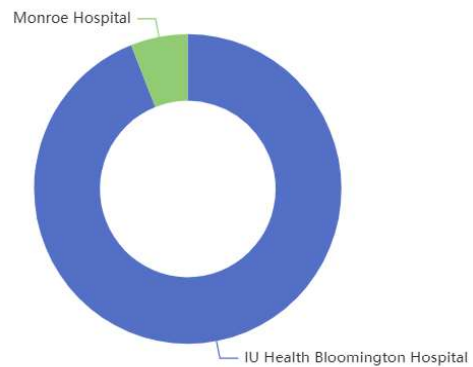

Average Turnout Time (Dispatch to Enroute)

STATION	EMS		FIRE		<u>All Incidents</u>
	<u>February</u>	<u>March</u>	<u>February</u>	<u>March</u>	
Station 21	2:37	1:23	1:14	1:28	1:22
Station 22	1:13	0:52	2:09	2:53	1:26
Station 23	1:36	2:43			2:43
Station 24	1:10	1:26	2:12	1:11	1:11
Station 25	0:57	1:20	1:36	1:36	1:19
Station 26	0:23	2:00		1:11	1:28
Station 29	1:06	0:58	2:49	1:07	1:02
Station 39	1:18	9:51	1:29	0:25	2:31
OVERALL AVERAGE TIME			1:53	1:19	

Average Response Time for All Calls (Dispatch to Arrival)

STATION	EMS		FIRE		<u>All Incidents</u>
	<u>February</u>	<u>March</u>	<u>February</u>	<u>March</u>	
Station 21	8:19	12:05	7:59	12:27	11:34
Station 22	6:46	7:27	13:49	16:07	9:33
Station 23	6:58	8:30			8:30
Station 24	12:43	10:03	12:37	8:43	10:12
Station 25	12:04	10:07	8:10	11:32	9:53
Station 26	2:58	11:06		9:44	10:09
Station 29	8:25	7:58	11:48	11:54	8:18
Station 39	8:33	14:07	6:23	8:35	11:03
AVERAGE FOR ALL STATIONS FOR ALL CALLS				9:45	
AVERAGE TIME SPENT ON SCENE				32:41	

90th Percentile Response Summary by Month

DISPATCH CALL CREATED	COUNT	90TH % TURNOUT	90TH % TRAVEL	90TH % TOTAL RESPONSE
Jan 2026	419	00:02:52	00:13:31	00:17:21
Feb 2026	367	00:03:16	00:13:28	00:16:10
Mar 2026	466	00:02:34	00:14:02	00:16:04
Total	1252	00:02:49	00:13:52	00:16:23

Incident Demand by Day and Time - March

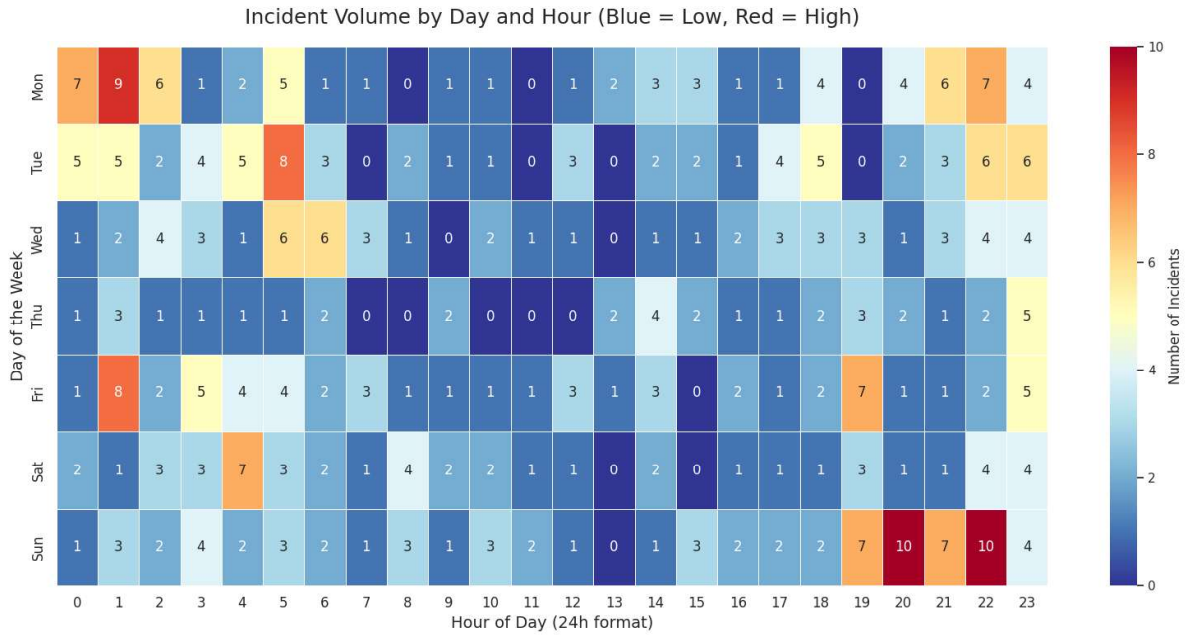

Ambulance Demand by Day and Time - March

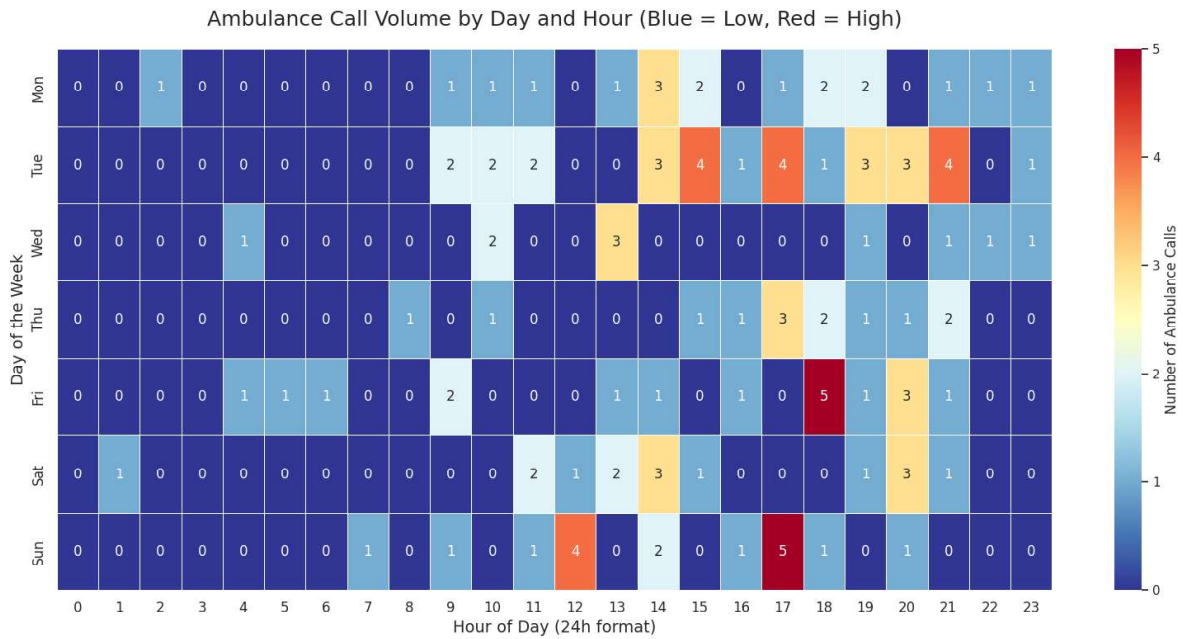

All Incident Heat Map - March

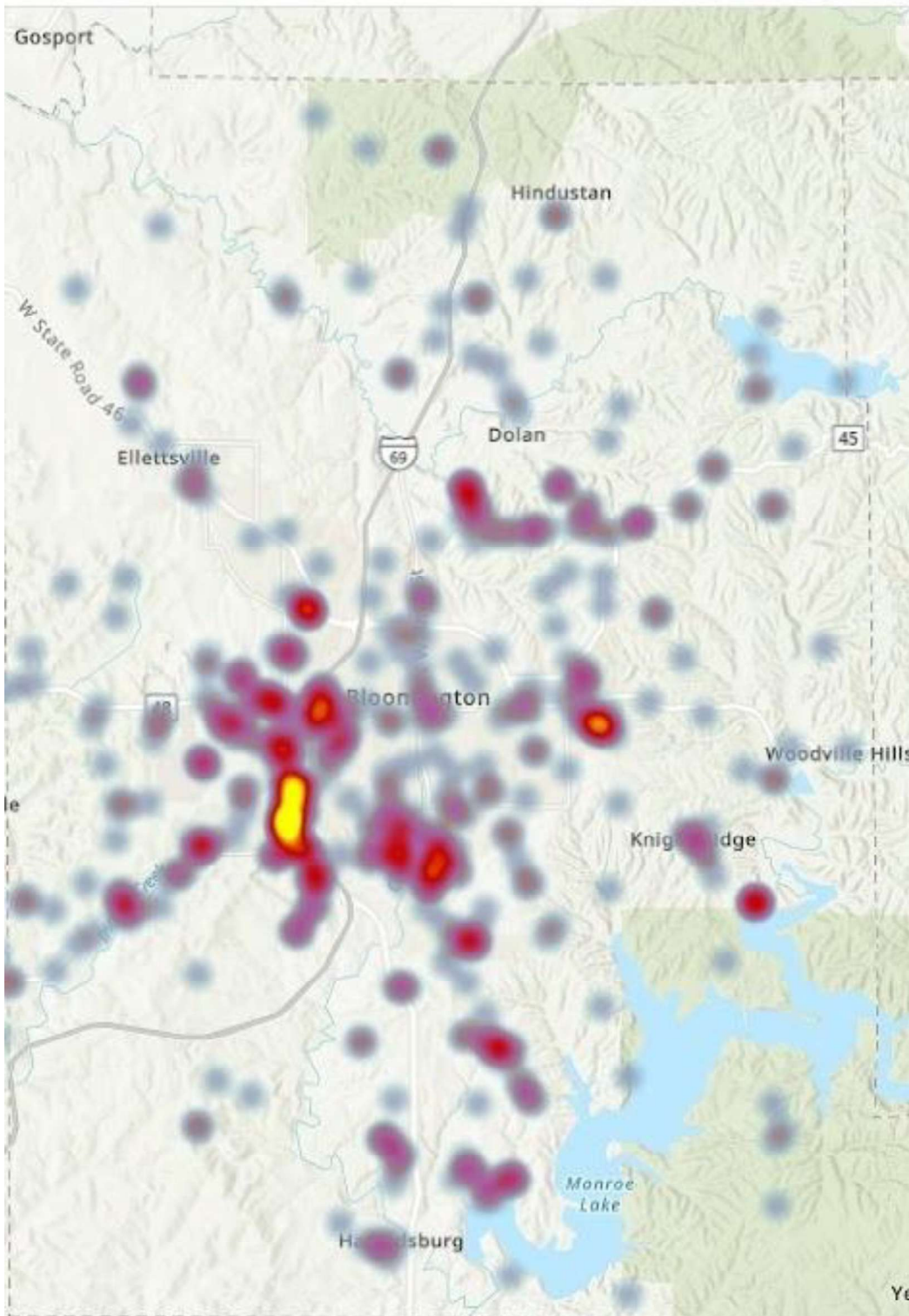

Ambulance Incidents Heat Map - March

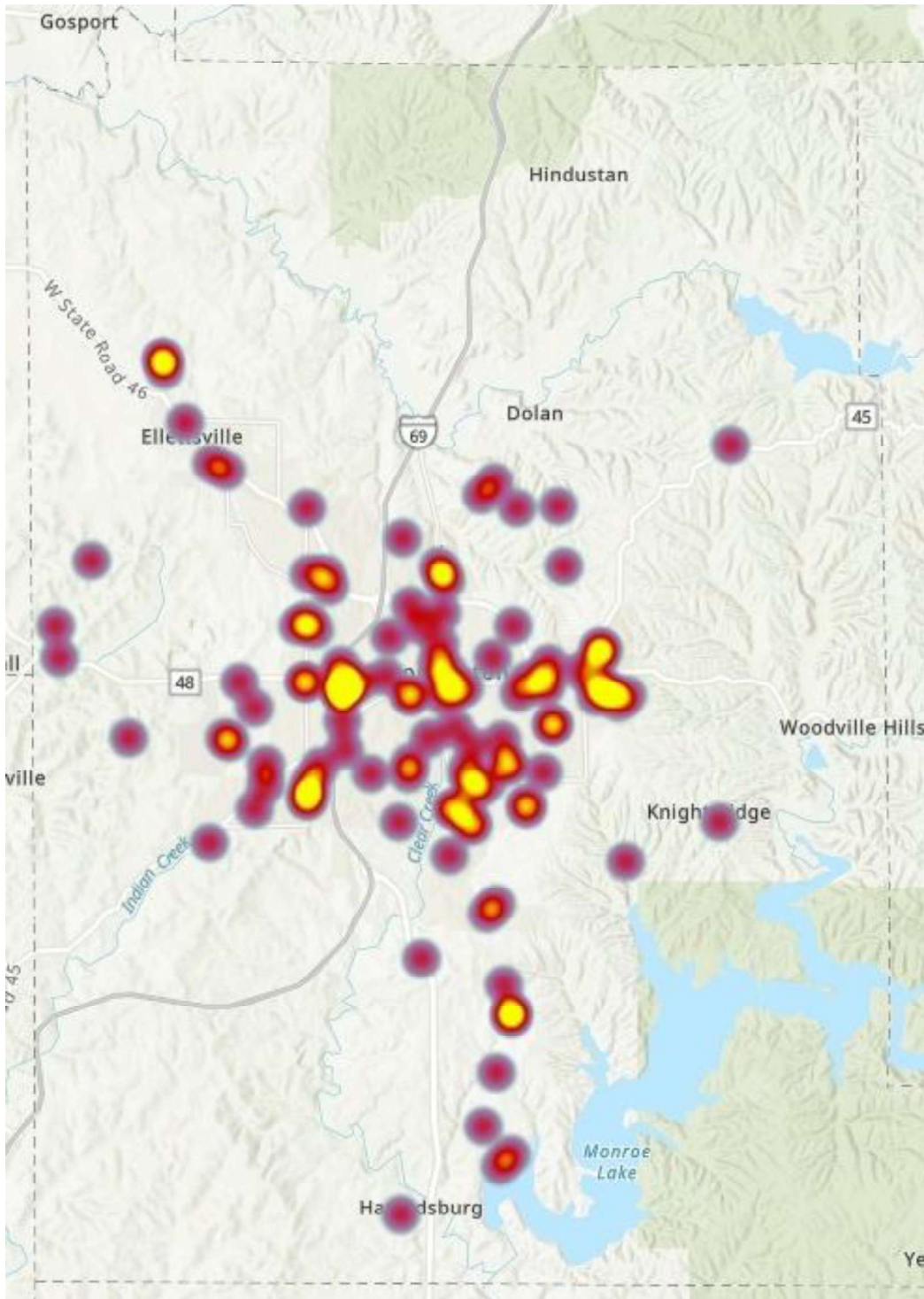

All Structure Fire Heat Map - March

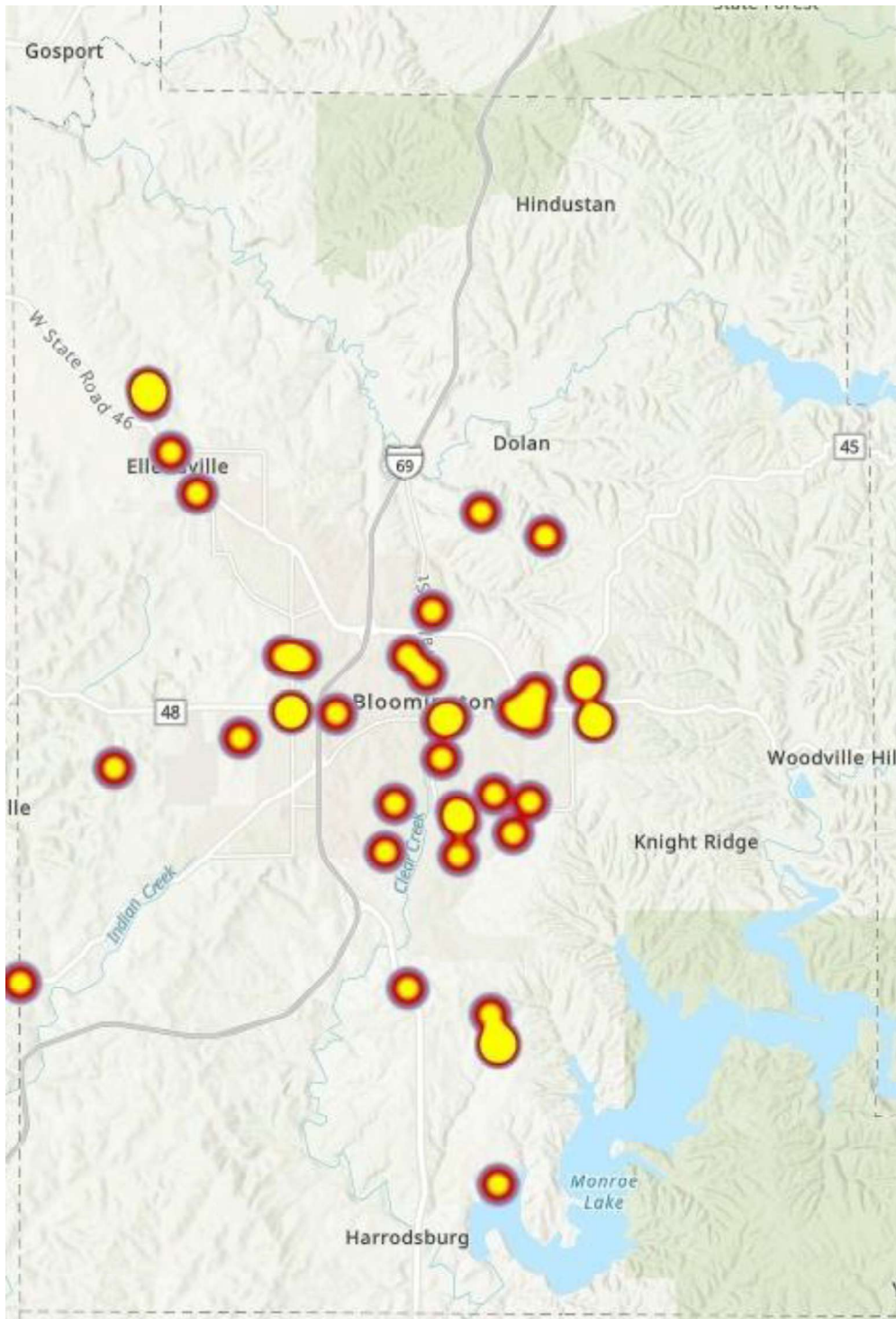

Operations & EMS Monthly Report April 2026

CURRENT SITUATION

Preparing to submit specifications for AFG station exhaust grant for bidding

Continuing work in First Due modules

- Customizing reports
- Cleaning up data entries, checklists

Continuing software module clean up, organizing and improving for operational efficiency

EMT students starting ride along with our ambulance

Began receiving new cardiac monitors, initiated set up, and preparing for distribution and training

Arrest Save x 3 (Station 29 / Station 22 x 2)

Working with Lt. Wellman on cascade system upgrades (station 21, mobile)

Multiple Vehicle Accidents with Entrapment

Structure Fire with fatality 3/28

ACCOMPLISHMENTS

Reporting Software Progress

- Concluded initial implementation with Software Implementation Team, and moved to our Customer Representative
- Completed training for Officers @ ODT
- All 2026 training Jan 1st to present entered into the system
- Completed roll out of all operational modules for staff
- Completed forms, links, and personnel general dashboard
- Completed initial Q/A and issue discussion with all three shifts

New Hires PERF77 physicals completed and results returned

Participated in Mass Casualty Incident (MCI) exercise at Memorial Stadium

PLANNED ACTIVITIES

Begin equipment imports of critical equipment (SCBA, Tools, Turnout) into First Due

Follow up training for specific software modules to improve operational effectiveness

Finalize specifications for Boat

Work to create a variety of long term options to address the EMS transport situation in the county

- Plan for districtwide FT ambulance service
- Plan for ALS integration
- Plan for expansion into whole county if called upon / requested

Operations continuity plan for reporting - emergency / non-emergency

Attend / Participate in District 8 EPPC conference and exercise

Fleet Monthly Report April 2026

CURRENT SITUATION

Work Orders

- Low Priority 7
- Medium Priority 26
- High Priority 6
- Completed 16
- OOS: 2 Out of service for 1+ Days
 - Engine 22 currently at Fire Service
 - Engine 26 Would not shift was repair, failed connection at TCM and ECM

Equipment Warranty claims in process

- 0

Engine 22

- Currently addressing warranty items such as ROM door Parts and cracked weld

Planned Trip to St Louis for April 8th

- Trip will involve meeting with ST louis Marine division and a trip to an Emergency Equipment and Apparatus vendor

Rescue Tools

- Currently upgrading Chainsaw chains and Sawzall blades to needed stations

Engine 23

- Currently evaluating air pressure issues on engine 23

Brush units

- Brush 21 prepared for service. Brush truck needs will be addressed at other stations

Mower 21

- Attempting to locate a replacement starter for mower 21

ID Tags

- Equipment ID tags purchased and ready for distribution

HME Spec

- Drawings, photos and spec sheet from HME obtained

ACCOMPLISHMENTS

Dodge Dakota

- The Dodge Dakota was used for training and sold for scrap

Fleet Maintenance and Repair

- Preventative Maintenance: Performed oil changes for Ambulance 25, Brush pump 23.
- Diagnostic & Repair: Successfully diagnosed and repaired Ambulance 22 air horn issues; resolved pump issues on Brush 23; and repaired a fuel leak on Engine 49. Battery issues corrected on UTV 24.
- Tire Management: Managed tire replacements and alignments for Engine 39 and Tender 22; crew identified tire damage on Tender 22 during routine inspection.
- Marine Fleet: Coordinated pickup and drop-off for Marine 24 and 25;
- Tested Marine 21 and returned it to active service after identifying and addressing vibration issues.
- General Service: Facilitated repairs for Brush 22 and managed the return of Engine 26 from Sternberg to station.
- All Mowers, Boats and UTV's Serviced

Planning & Asset Procurement

- New Equipment Specs: Developed and updated detailed specifications for the new engine and HME spreadsheet; coordinated with the crew on final specs.

- Strategic Planning: Drafted new boat plans and organized a trip to St. Louis for a boat demo with St. Louis Fire.
- Quoting & Proposals: Drafted and submitted several high-value proposals, including TNT tool quotes, mower proposals
- Scheduling: Successfully scheduled upcoming pump tests, aerial inspections, ladder tests, and Genesis/TNT preventative maintenance for the fleet.
- Supply Management: Sourced and distributed critical supplies for mowers, UTVs (Stations 22-25), and chainsaw components (Stations 39 & 29).
- Safety & Personnel: Participated in interview meetings and managed PT assessments for the team.

Fleet Sales Meeting

- Met with local Auto Dealership to address specifications of future vehicles

PLANNED ACTIVITIES

Annual Service

- Prepare for annual services and testing of equipment

Implemented ethanol free fuel plan

- Fuel stations and logistics of ethanol free fuel distribution

Meet with 911 Fire and Fleet

- Meet with vendor to discuss apparatus

Chief 23

- Chief 23 to JTN

Engine 22

- Follow up Follow up on engine 22 repairs

Brush 26

- Relocate apparatus for brush/squad26

Apparatus and Marine unit

- Continue to explore Apparatus and Boat options

Plymovent

- Plan for the upgrades and Install to the Plymovent systems

Generator Services

- Continue to explore generator service plans

FDIC

- Attend FDIC

Chainsaw Chains

- Explore other chainsaw chain options. Currently communicating with a lumberyard contact for recommendations

Marine Units

- Develop a monthly schedule to operate the marine units on the lake

Facilities & Logistics Monthly Report April 2026

CURRENT SITUATION

- Waiting on estimates for steel door and attic access ladder replacement at 25
- Still working with electrician on estimates for electrical issues at Station 21
- Working on Plymo-vent repair at station 24
- Working on getting stump removed from rear of building at station 25
- Working with Station 23 to move old playground equipment to 21 for possible future use

ACCOMPLISHMENTS

- Garage door has been ordered for Station 39
- New dryer at Station 25
- Replaced dryer vent cover at HQ
- Repaired downspout damaged from storm at Station 29
- Installed new LED lighting in upstairs storage at Station 21
- Picked up lighted sign and delivered to Station 25 for breakfast with the bunny
- Delivered tables and chairs to Station 25 for breakfast with the bunny
- New refrigerator at Station 21
- Delivered mulch and wood chips to station 25(donated by Bluestone Tree)
- Removed unused exercise equipment from station 26
- Moved manlift to Station 39 to change light in bay
- Replaced flush valve in toilet at station 29
- Griddle moved from Station 21 to 25 for breakfast with the bunny
- Purchased pallet of water from Sams

PLANNED ACTIVITIES

- Blow in insulation at Station 23
- Replace down stairs entry door at HQ Annex
- Replace broken/missing fence around generator at Station 29
- Quarterly supply distribution to all stations
- Have damaged asphalt looked at for repair at Station 22
- Rip rap at station 26 to help with erosion
- Possible concrete pad replacement at Station 29

Training Monthly Report April 2026

CURRENT SITUATION

- Working with BFD Logistics to coordinate use of fork lift for moving additional drywall for storage.
- Working with Lamar (Billboard company) to choose a site location for upcoming rope rescue training.
- Continue to work with BFD on upcoming Recruit Academy
- Reorganizing pole barn at St. 25 in preparation for Recruit Academy
- Company Level Training: Severe Weather, EMS Audit & Review, WPE Make-Up, Wilderness Search, Project Lifesaver, Driver Operator Pump Panel Ops, Engine Company Operations
- Providing Hazmat refresher training to Monroe County Central Dispatch. All day and night shift personnel will attend the training across multiple sessions at St. 25
- Updating our current roster in Acadis Portal to include new volunteers.
- Meeting with all three shifts to obtain feedback on First Due Training entries
- Reviewing all First Due Training entries for accuracy, providing feedback to personnel
- Meeting with tower company representatives to learn about incidents involving towers as well as look at the tower at St. 25 for possible training.
- Planning walkthrough/Preplans of Simtra BioPharma Solutions at 927 S. Curry Pk.
- Scheduling Ivy Tech, Hoosier Hills and Eastern Fire for use of Training Facilities
- Evaluating area trails for Wilderness Search/Wildland Fire training
- Working with Admin to purchase Conex containers through IDHS grant
- Driver Operator Mobile Water Supply course - 3 MFD members completing on shift
- ARFF Live Fire course at Monroe County Airport
- MFD & BFD Gold shifts partnering to do Tech Tuesday training

ACCOMPLISHMENTS

- Company Level Training: Streets and Maps, Auto Extrication (IC), Auto Extrication Scene Size Up & Safety, Vehicle Stabilization, Extrication Skills, Ropes & Knots
- Provided a video and how to document for First Due Training documentation
- Ice Rescue written tests/makeups
- Assisted members with training reports and completion of forms for EMT recertification
- Officer Development Training (ODT #19) @ St. 21
- Began using First Due for all Training Documentation
- Provided (1) IFSTA Inspector book to IU Emergency Management for course
- Transitioned training documentation from Image Trend to First Due - Jan. 1st - Mar. 14th
- Dubois County Fire School March 13-15 and March 20-22
- Worked with Admin to purchase training manikins through IDHS grant
- IAFF Hazmat Training grant submitted for Hazmat Technician course
- Assisted St. 25 crew with ground work to prep for Breakfast with Bunny
- Provided information for MFD quarterly newsletter
- Vehicle Extrication Skills Days at Ken's Westside for all companies, including scenario based response for all crews
- Vehicle Extrication day for Volunteers/Substitutes. March 25th @ St. 29

- Members attended additional outside training. Topics include: Annual Fire Officers Seminar, Chaplain Training Course and Live Fire VES, Project Lifesaver conference, Inspectors conference, Fire Officer Strategy & Tactics
- Completed CPR Instructor course
- Personnel participated in IC-EMS Annual MCI Drill @ Memorial Stadium

PLANNED ACTIVITIES

- FDIC April 20-25
- Company Level Training: UTV Safety Course, Hazmat Ops, Water Supply Considerations, SCBA, Victim Drags/Carries, Moving Downed Firefighters, EMS Care for Fire Victims
- Working with District 8 on approval of District funded courses for Fall/Winter 2026
- Planning Leadership Development course with IDHS for Winter 2026 to be hosted at Van Buren Twp. Community Building
- Search & Rescue course for Rescue personnel
- Working with Cpt. Fisher to develop next Hazmat quarterly training - explosives
- Members signed up to attend CIRT Training, Instructor I, Confined Space Ops/Tech.
- Working with J. Shaw to evaluate site prep for training prop
- Continue working with Hoosier Hills and Ivy Tech to provide training resources
- Planning continues for Recruit Academy: EMT - May 4th, Fire - June 1st
- Work with St. 25 crews for Training ground prep for Academy
- Planning for Trench Rescue training day in early Fall
- EVOC training for all drivers - Engines, Ambulances, UTV's
- Assist Eastern Greene Fire Territory with Live Fire skills training
- Volunteer training opportunity - Project Lifesaver @ St. 29 on April 14th
- Evaluating residential properties on west side of Bloomington for potential training

February Training Hours - 2104

March Training Hours - 2718.75

Community Risk Reduction Monthly Report April 2026

CURRENT SITUATION

Update CPR presentation to 2025 program

- Two classes given in March as Beta tests

Research 3D scanner for fire investigations and other applications

CERT Class March 26-April 18

Working with the Monroe County Sheriff's Office on Arson Case

- Preliminary report filed with Monroe County Prosecutor

Creating a program for Citizen Fatality Notification and Family Support

- Beta testing

Collaborating with Meadows Hospital regarding Spice/K2 vaping pods psychosis prevention presentation to be delivered regionally

- First presentation June

Creating Master Scenario Events List (MSEL) for Homeland defender international disaster drill

Finding alternative housing for displaced residents after fire

Investigating hazardous condition in neighborhood with Monroe County Solid Waste District

Researching an AI emergency monitoring company regarding errors in notifications

ACCOMPLISHMENTS

City Hall Display Case Program for the month of April 2026

Bethel Lane Fire Investigation

- Provide occupants with access to assistance

Attended FEMA Incident Support Team (IST) Orientation Training

Installed Smoke Alarms for elderly resident

Attended the Deputy Drive Memorial

Assisted multiple families post terminal event

Attended autopsy for possible substance overdose

Data transition for Prevention Activities into First Due Software

Provided information and support to Anderson Road Family

- Returned released personal items from MCSO evidence

Attended Monroe County Domestic Violence Prevention Coalition meeting

- Training Topic: Firefly Children and Family Alliance

Attended Ethics Training: MHA of Monroe County

Updated CRR Safer Grant information

Attended the Monroe County Address Committee Meeting

Fire Marshal Division attended Indiana Fire Inspectors Conference

Fire Marshal Division attended Fire Inspector I/II/III Certification

Recorded Promotional Video for serving on Boards and Committees in Monroe County

Attended Homeland Defender Concept Development Conference

Attended Suicide and Overdose Fatality Review Committee

Attended Human Rights Commission Meeting

- Approved annual report

Attended the Mental Health America of Monroe County Directors' meeting

Adult Services/Area 10

- 4 referrals for assistance

Events: Breakfast with the Bunny, Fire and Life Safety Officer Lecture *Inclusive Magic: Creating Moments for All Abilities* at the Indiana Fire Inspectors Conference

NaloxBoxes

- Distributed 7 opioid rescue kits

Completed Fatal Fire Investigation Strain Ridge Rd

Attended Autopsy of Fatal Fire Victim

Provided information to family of fire victim regarding fire events

PLANNED ACTIVITIES

Healthapalooza BHSS April 23

Expand delivery of CPR and QPR to public feasibility research

Cooperative program with United Way/Red Cross regarding public education for disaster preparedness

Presenter 2026 IU Rural Conference

Create PEER support program in FEMA Sub Group for FEMA Incident Support Team during disaster deployments

Hoosier Burn Camp teen lake outing

Consulting for an AI powered Search and Rescue Program (Wide Area and Collapse)

- Reviewed first draft of system

FIRE SAFETY INSPECTIONS

23 - Inspections

0- Re-inspections

3- New Construction

0- Plans Review

4-Consultations

Financial Monthly Report April 2026

CURRENT SITUATION

- GAAP Report Submission Reviews underway for bank reconciliations & pension contributions.
- FORVIS GAAP bank account authorizations being prepared for audit access.
- Discussions with other Monroe County Government Component Units regarding H&W Fees.
 - Consensus being favorable for rates, ease of submission and consistency.
- Weekly Claims & Receipt processing including Vendor communications & setup

ACCOMPLISHMENTS

- Researched investment opportunities for MFPD cash balances to be discussed in New Business.
 - Contacted SBOA to confirm investment opportunities are allowed
- Participated in the DLGF webinar concerning Budget 2.0 launch this spring
- EMS Collections report completed and funds transferred
- Represented MFPD at the Batchelor Middle School Reality Store.
 - Discussed the need for home, auto and life insurance with about 250 kids.
- Investigated and corrected a deposit issue with MedBill Zelis deposits being posted as checking deposits instead of savings deposits at PSB. Test deposits were entered and the issue is resolved.
- Received the March Local Income Tax (LIT) Revenue \$380,971.66

PLANNED ACTIVITIES

- Review our Donation Fund process in accordance with SBOA March Bulletin
- Budget 2.0 in-person training. Date and location TBD
- Review Internal Controls and validate member affidavits

EMS Revenue and Collections Summary

31-Mar-26

<u>Month</u>	<u>Charges</u>	<u>Payments</u>	<u>Adjustments</u>	<u>Bad Debt</u>	<u>Active AR</u>	<u>MFD Standby</u>
Sep-Dec 2024	\$ 178,373.92	\$ (35,125.82)	\$ (67,151.25)	\$ -	\$ 76,096.85	
Jan-25	93,871.20	(14,299.80)	(25,874.42)	-	129,793.83	
Feb-25	92,904.80	(20,014.39)	(51,519.95)	-	151,164.29	
Mar-25	41,813.68	(17,404.32)	(46,652.96)	-	128,920.69	
Apr-25	51,679.68	(16,719.93)	(32,302.93)	(26,830.60)	104,746.91	
May-25	69,034.84	(15,678.38)	(37,487.15)	(6,243.46)	114,372.76	
Jun-25	43,359.24	(11,313.57)	(35,278.02)	-	111,140.41	
Jul-25	71,671.64	(27,176.78)	(53,492.51)	(13,641.86)	88,500.90	
Aug-25	45,090.44	(14,991.16)	(22,411.15)	(10,074.18)	86,114.85	
Sep-25	57,018.72	(12,884.89)	(29,342.80)	(7,058.16)	93,847.72	2,000.00
Oct-25	59,629.24	(10,916.37)	(36,514.68)	(13,954.02)	92,091.89	800.00
Nov-25	68,877.60	(12,012.31)	(20,819.52)	(2,798.06)	125,339.60	2,000.00
Dec-25	57,514.60	(20,307.98)	(48,099.33)	(3,310.87)	111,136.02	800.00
Jan-26	36,719.80	(12,081.65)	(28,499.70)	(5,033.77)	102,240.70	-
Feb-26	33,851.00	(14,241.26)	(29,070.78)	(10,783.43)	81,996.23	1,200.00
Mar-26	56,815.00	(8,560.73)	(24,362.19)	(3,811.83)	102,076.48	-
Total	1,058,225.40	(263,729.34)	(588,879.34)	(103,540.24)	102,076.48	6,800.00

Current Month Adjustments:

*AA MEDICARE ALLOWANCE	(13,921.62)
*AC ANTHEM BCBS COMMERCIAL WRITE OFF	(2,810.23)
*AC COMMERCIAL ALLOWANCE	-
*AD MEDICAID ALLOWANCE	(2,569.17)
*AI CHARITY/HARDSHIP/HOMELESS	(1,733.40)
*AO DECEASED	(3,326.80)
*AO INTEREST ADJUSTMENT	-
*AO PROCESSING FEE	(0.97)
*AO TOO SMALL TO PURSUE	-
*AO NEGOTIATED DISCOUNT	-
*PR REFUND	-

WriteOff (Adjustments) (24,362.19)

Special Fire General - Fund 8603		Encumbrances	Adjusted Budget	Current Month Expenditures	YTD Expenditures	% Expended	Balance Remaining
		Transfers		Change fx			
Personal Services							
8212	Fire Chief		\$ 96,400.00	8,033.34	\$ 23,908.39	24.8%	\$ 72,491.61
8213	Deputy Chief (4)		\$ 361,460.00	30,121.68	\$ 89,647.52	24.8%	\$ 271,812.48
8214	Assistant Chief (3)		\$ 168,680.00	14,056.68	\$ 41,835.46	24.8%	\$ 126,844.54
8215	Battalion Chief (6)		\$ 391,650.00	26,110.00	\$ 77,706.68	19.8%	\$ 313,943.32
8216	Fire Marshal (2)		\$ 156,660.00	13,055.00	\$ 38,853.34	24.8%	\$ 117,806.66
8217	Fleet Manager (1)		\$ 78,330.00	6,527.50	\$ 19,427.08	24.8%	\$ 58,902.92
8219	Firefighters Salary - PERF Fund (9)		\$ 688,149.00	50,973.28	\$ 157,926.56	22.9%	\$ 530,222.44
8220	Firefighters Salary - 1977 Fund (78)		\$ 5,963,958.00	455,572.87	\$ 1,362,532.05	22.8%	\$ 4,601,425.95
8221	Incentive Qualifications		\$ 218,800.00	5,608.16	\$ 17,082.81	7.8%	\$ 201,717.19
8222	Officer Pay		\$ 702,000.00	54,838.00	\$ 149,327.00	21.3%	\$ 552,673.00
8223	Longevity		\$ 172,050.00	12,818.75	\$ 37,925.00	22.0%	\$ 134,125.00
8224	Holiday Pay		\$ 57,750.00	-	\$ 17,925.00	31.0%	\$ 39,825.00
8226	Part-Time Employees (15FTEq)		\$ 698,800.00	51,416.36	\$ 170,058.99	24.3%	\$ 528,741.01
8227	Subs, Emer, OT, Training, Sp Evt		\$ 605,000.00	87,682.01	\$ 203,608.59	33.7%	\$ 401,391.41
8228	Administrative Assistant (2)		\$ 161,034.00	13,419.52	\$ 39,939.14	24.8%	\$ 121,094.86
8229	IT Specialist (1)		\$ 89,425.00	7,452.08	\$ 22,178.53	24.8%	\$ 67,246.47
8230	Trustee Compensation (7)		\$ 28,341.00	7,084.00	\$ 7,084.00	25.0%	\$ 21,257.00
8231	Ambulance Staffing		\$ -	38,931.73	\$ 110,520.07	#DIV/0!	\$ (110,520.07)
8235	Uniform Allowance		\$ 169,000.00	-	\$ -	0.0%	\$ 169,000.00
8254	Early Retirement		\$ 25,000.00	-	\$ -	0.0%	\$ 25,000.00
8240	Social Security		\$ 194,170.00	14,783.00	\$ 43,087.42	22.2%	\$ 151,082.58
8241	Medicare		\$ 156,708.00	12,464.84	\$ 36,595.75	23.4%	\$ 120,112.25
8242	Unemployment Insurance		\$ 20,000.00	427.47	\$ 427.47	2.1%	\$ 19,572.53
8243	Health Insurance (M/D/VV/CI/EN)		\$ 2,153,763.00	169,398.47	\$ 392,506.61	18.2%	\$ 1,761,256.39
8244	PERF 1977 Employer Contribution		\$ 1,877,500.00	141,312.04	\$ 426,573.00	22.7%	\$ 1,450,927.00
8245	Group Life/ADD/STD/LTD Ins		\$ 167,600.00	25,134.98	\$ 37,911.23	22.6%	\$ 129,688.77
8246	PERF Fund Employer Contribution		\$ 386,757.00	23,902.62	\$ 68,294.37	17.7%	\$ 318,462.63
8255	Post-Employment Health Insurance		\$ 60,000.00	-	\$ -	0.0%	\$ 60,000.00
8251	Volunteer Contract		\$ 12,500.00	-	\$ -	0.0%	\$ 12,500.00
8252	Length of Service		\$ -	-	\$ -	#DIV/0!	\$ -
8253	Medical Services	\$ 2,406.90	\$ 127,406.90	3,405.59	\$ 6,230.43	4.9%	\$ 121,176.47
		\$ 2,406.90	\$ 15,988,891.90	\$ 1,274,529.97	\$ 3,599,112.49	22.5%	\$ 12,389,779.41
Supplies							
8300	Office Supplies		\$ 20,000.00	742.03	\$ 1,497.62	7.5%	\$ 18,502.38
8303	Promotional Supplies		\$ 17,500.00	-	\$ -	0.0%	\$ 17,500.00
8313	Inspection/Investigation Supplies		\$ 1,250.00	-	\$ -	0.0%	\$ 1,250.00
8301	Operating Supplies	\$ 1,613.47	\$ 134,113.47	11,188.34	\$ 29,936.89	22.3%	\$ 104,176.58
8304	EMS Supplies		\$ 40,000.00	454.67	\$ 4,934.97	12.3%	\$ 35,065.03
8306	IVFA Dues		\$ 3,500.00	-	\$ -	0.0%	\$ 3,500.00
8308	Fuel		\$ 160,000.00	9,605.20	\$ 30,414.23	19.0%	\$ 129,585.77
8311	Special Chemical Supplies		\$ 5,000.00	-	\$ -	0.0%	\$ 5,000.00
8312	Fire Prevention Education Supplies	\$ 975.65	\$ 12,975.65	-	\$ 1,522.65	11.7%	\$ 11,453.00
8314	Hazardous Materials Mitigation		\$ 10,000.00	-	\$ -	0.0%	\$ 10,000.00
8302	Vehicle Maintenance Supplies	\$ 11,199.42	\$ 121,199.42	5,145.62	\$ 27,593.81	22.8%	\$ 93,605.61
8315	Color Guard Supplies		\$ 2,000.00	-	\$ -	0.0%	\$ 2,000.00
		\$ 13,788.54	\$ 527,538.54	\$ 27,135.86	\$ 95,900.17	18.2%	\$ 431,638.37
Services & Charges							
8351	Seminars/Training		\$ 60,000.00	7,790.02	\$ 11,210.66	18.7%	\$ 48,789.34
8352	Legal Counsel & Expenses	\$ 6,177.12	\$ 51,177.12	4,293.50	\$ 9,516.50	18.6%	\$ 41,660.62
8353	Equipment Tests/Certifications		\$ 80,000.00	-	\$ -	0.0%	\$ 80,000.00
8355	Accounting Services		\$ 69,920.00	10,135.00	\$ 20,805.00	29.8%	\$ 49,115.00
8401	Contractual Services	\$ 12,055.00	\$ 97,055.00	2,495.16	\$ 46,409.96	47.8%	\$ 50,645.04
8400	Telephone & Data Services		\$ 81,000.00	4,272.14	\$ 21,408.54	26.4%	\$ 59,591.46
8403	Travel Expenses		\$ 15,000.00	20.00	\$ 46.69	0.3%	\$ 14,953.31
8450	Legal Advertising		\$ 1,000.00	22.26	\$ 62.02	6.2%	\$ 937.98
8451	Printing		\$ 1,000.00	-	\$ -	0.0%	\$ 1,000.00
8500	General Insurance		\$ 196,000.00	29,160.57	\$ 106,274.07	54.2%	\$ 89,725.93
8501	Worker's Compensation Insurance		\$ 210,000.00	-	\$ 25,976.00	12.4%	\$ 184,024.00
8550	Utilities		\$ 162,500.00	12,976.97	\$ 42,176.31	26.0%	\$ 120,323.69
8354	Computer Tech Support	\$ 398.17	\$ 40,398.17	1,247.98	\$ 4,452.29	11.0%	\$ 35,945.88
8600	Building Services		\$ 50,000.00	8,044.41	\$ 13,908.97	27.8%	\$ 36,091.03
8605	Equipment & Vehicle Repairs	\$ 8,875.99	\$ 108,875.99	5,608.47	\$ 25,443.16	23.4%	\$ 83,432.83
8402	Postage & Fees		\$ 1,500.00	142.55	\$ 185.50	12.4%	\$ 1,314.50
		\$ 27,506.28	\$ 1,225,426.28	\$ 86,209.03	\$ 327,875.67	26.8%	\$ 897,550.61
		\$ 43,701.72	\$ 17,741,856.72	\$ 1,387,874.86	\$ 4,022,888.33	22.7%	\$ 13,718,968.39

Special CUM Fire - Fund 8691	Encumbrances	Adjusted Budget	Current Month Expenditures	YTD Expenditures	% Expended	Balance Remaining
	Transfers					
Capital Outlays					25.0%	
8782 Station 21 Mortgage		\$ 293,795.00	-	\$ 293,790.97	100.0%	\$ 4.03
8784 Building Renovations	\$ 22,662.94	\$ 172,662.94	3,330.00	\$ 29,750.56	17.2%	\$ 142,912.38
8779 Small Vehicles		\$ 160,000.00	1,300.00	\$ 3,228.00	2.0%	\$ 156,772.00
8780 Misc, Equipment & Capital Outlays	\$ 7,740.99	\$ 231,490.99	800.00	\$ 9,147.21	4.0%	\$ 222,343.78
8781 Personal Protective Equipment (PPE)	\$ 44,074.50	\$ 219,074.50	1,627.92	\$ 5,574.82	2.5%	\$ 213,499.68
8785 Rescue 11 (22) Replacement		\$ 120,511.00	-	\$ 40,170.41	33.3%	\$ 80,340.59
8788 Engine 22		\$ 128,876.00	-	\$ 64,437.78	50.0%	\$ 64,438.22
8790 Apparatus Replacement	\$ 19,689.07	\$ 169,689.07	-	\$ 19,689.07	11.6%	\$ 150,000.00
	\$ 94,167.50	\$ 1,496,099.50	\$ 7,057.92	\$ 465,788.82	31%	\$ 1,030,310.68

Special Rainy Day - Fund 0061	Encumbrances	Adjusted Budget	Current Month Expenditures	YTD Expenditures	% Expended	Balance Remaining
	Transfers					
Capital Outlays					25.0%	
8761 Apparatus Purchase		\$ 1,700,000.00	-	\$ -	0.0%	\$ 1,700,000.00
	\$ -	\$ 1,700,000.00	\$ -	\$ -	0%	\$ 1,700,000.00

Administrative Monthly Report April 2026

CURRENT SITUATION

Document prep and scheduling for administration obligation for upcoming hiring process
Conditional offers going to 5 Full Time hires to fill vacancies in 2026 budget
Assisting in planning for recruit school beginning on April 30th
Following up with candidates that request to review improvements and placements on hiring list
Working with Ivy Tech on upcoming Recruit School needs
Spring Cleaning for HQ
Finalizing specifications for new fire engines
Working on 2025 Annual Report
Setting up presenters for recruit orientation
Clothing orders for upcoming recruit class

ACCOMPLISHMENTS

Met with installer to discuss future Location Alerting Systems
Met with all Monroe County Fire Chiefs
Scheduled 9 Volunteers to attend FF ½ Courses at 3 location to begin fire certification process
MFD Crews attended Deputy Driver Memorial service
90 Day review of Rescue Company
Received the Zoll Monitors purchased by VB Township for Engines
Met with Station 21 personnel to look at a sonar tool
Officer Development Training #19
Met with Hoosier Hills Career Center leadership to grow our partnership
Attended parts of the Fire Inspectors of Indiana Association annual conference
Monroe County Fire Chiefs meeting revising county-wide operational documents in preparation for automatic aid
INPRS 1977 Fund Pension Board activities
Attended Rescue Training organizational meeting
Breakfast with a Bunny
Contributed a pot of Chili to the Smithville Area Association Chili Supper
Spoke with Indiana Volunteer Firefighters Association leadership regarding previous legislative session
Met with Legal on Voluntary Life Jacket Program for Lake Monroe
Did promotional spot on Radio for Breakfast with Bunny event

PLANNED ACTIVITIES

Hoosier Hills Job Expo
Meeting with Roots for payroll and financial yearly review
MCCSC School Safety Committee meeting
Fire Department Instructors Conference
Start Recruit Class 007
Hosting Indiana Chiefs at VB Township for Legislative update and other topics
Indiana Fire Chief's Association Meeting and Day at the Track (Speedway)
Fire Camp for local youth in categories, elementary, middle and high school
Upcoming trip to Fire Dex manufacturing facility in Ohio to review the process and quality
Transitioning from 28 day to 14 day pay cycle

PERSONNEL

New Hires: Full-time: 5 Part-time: 5 Substitutes: 0 Resignations: 1 Retirements: 0 Volunteers: 7

Volunteer Hours: 000 hours



(877) 637-3473

Quote

Quote # QT2052946
Date 03/30/2026
Expires 04/14/2026
Sales Rep Cornejo, John
Shipping Method FedEx Ground
Customer Monroe Fire Protection District (IN)
Customer # C42291

Bill To

Monroe Fire Protection District (IN)
 Captain Mark Mahurin
 2123 S. Kirby Rd
 BLOOMINGTON IN 47401
 United States

Ship To

Monroe Fire Protection District (IN)
 Mark Mahurin
 9094 S. STRAIN RIDGE RD
 Bloomington IN 47401
 United States

Item	Alt. Item #	Units	Description	QTY	Unit Price	Amount
Aeroflex Coat			Custom Aeroflex Coat	12	\$2,605.00	\$31,260.00
Aeroflex Pant			Custom Aeroflex Pant	12	\$1,828.00	\$21,936.00
FIRE INNOVATIONS			Custom FIRE INNOVATIONS	12	\$132.95	\$1,595.40

Subtotal \$54,791.40

Contact: C42291 Monroe Fire Protection District (IN) : Mark Mahurin (812) 327-9734

Shipping Cost \$0.00

Tax Total \$0.00

Total \$54,791.40

This Quotation is subject to any applicable sales tax and shipping and handling charges that may apply. Tax and shipping charges are considered estimated and will be recalculated at the time of shipment to ensure they take into account the most current information.

All returns must be processed within 30 days of receipt and require a return authorization number and are subject to a restocking fee.

Custom orders are not returnable. Effective tax rate will be applicable at the time of invoice.



QT2052946



February 18, 2026

Monroe Fire Protection District #26
478 E Chambers Pike
Bloomington IN 47404

Cassady Electric is pleased to offer a quote to do the following to add a 24Kw Generac generator to the main service which will include the following:

- Installing generator pad next to meter base
- Demo existing transfer switch
- Install Generac transfer switch
- Install a 24Kw Generac generator
- Install conduit and wiring for power and controls between transfer switch and generator
- Purchase permit from Monroe County Building Department
- Commercial Service to do the following:
 - o Install a ¾" gas line from the gas main at the building to the new 24KW generator.
 - o Surface mount the gas line to the building.
 - o Install a gas regulator, shut off valve, flex connector and drip leg at the unit.
 - o Includes materials and labor

For the sum of: \$14,200 (Fourteen thousand two hundred dollars)

Respectfully

Shawn Trendelman

Cassady Electric

Mailing Address:
P.O. Box 53
Ellettsville, IN 47429

Business Address:
5600 W. State Road 46
Bloomington, IN 47404

Phone: (812) 332-7361
Fax: (812) 650-7182



9000 N. Kentucky Ave.
 Evansville, IN 47725
 Phone: 812-867-9900
 Fax: 812-867-2388



To:	Bill Tusing Monroe Fire Protection District	Quotation #:	JF02032026-1
		Date:	02/25/2026
		Ref:	Station#26

We are pleased to quote the following new equipment for your consideration:

- Quantity 1 Model 7327 Generac Generator
 - 26KW
 - 120/240 Volt 1 Phase
 - Sound Attenuated Enclosure
 - Natural Gas or LP compatible
 - Battery Charger
 - Lead Acid Start Battery

- Quantity 1 Model 9952
 - Auto Switch
 - 200 Amps
 - Service Entrance Rated
 - NEMA 3R Enclosure
 - Exerciser Clock

- Quantity 1 Model 7000
 - 50A Smart Management Auto Load Shed Module
 - for the air compressor

- Quantity 1 Genpad

Remote monitoring, Mobile Link, and 1st year subscription, included.

Included:

Quantity one (1) lot delivery of generator to site.
 Quantity one (1) lot delivery of ATS to site.

One (1) lot installation and contracting work & installation of new generator and new ATS (Automatic transfer switch) and new auto load shed moduel per these details.

- Install a new 26KW propane generator and 200-amp SE Rated ATS and load shed moduel.
- Provide new conduit from new outdoor ATS location to new generator
- Provide and install wiring (conductors, building power, and control wiring as needed), for generator and ATS.
- Install new propane gas regulator and hook up new generator to gas supply.

- Receive, handle new generator and ATS and place on pad & wall accordingly.
- Final grading and seeding, if needed, by others after work is complete.

Quantity one (1) on site generator run test, system test, gas supply check, warranty check, & customer training by factory certified technician (if customer present during same trip.) Site test is 1 trip, normal business hours, after complete and accurate installation by others.

Quantity one (1) year, 1st year only, planned maintenance included.

TOTAL NET PRICE: \$24,912.00

Add \$2,000.00 to make the quoted 26KW propane generator be a 28 KW propane generator.

<p>Price Includes: 1) Prints, drawings and manuals 2) Battery, Oil, and Antifreeze</p>	<p>Note: 1) Applicable Taxes NOT included 2) Terms: Net 30 Days With Approved Credit 3) Quote good for 28 days.</p>
---	---

Please call, text, or email me anytime with any questions or challenges. Thank you very much.

Sincerely,

Derrick L Crecelius
 Power Systems Sales Consultant

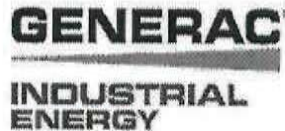

317-783-5434 office
 317-771-0110 cell
 317-783-5870 fax

www.evapar.com

Evansville, IN – Indianapolis, IN – Ft. Wayne, IN – Louisville, KY – Memphis, TN – St. Louis, MO



Exhibit A

GENERAC[®]

Salesperson: J. Reynolds

Name: Monroe Fire Station 26
 Address: 478 E Chambers Pike
 City: Bloomington State: IN Zip Code: 47404 Phone: 817-837-3347

Air Cooled Generator	Price	Quantity	Amount
26kw/200amp Model Number 7291	\$7599.00		
24kw/200amp Model Number 7210	\$7099.00	1	7109
22kw/200amp Model Number 7043	\$6709.00		
18kw/200amp Model Number 7228	\$6109.00		
14kw/200amp Model Number 7225	\$5279.00		
14kw/100amp Model Number 7224 16 Circuit	\$5039.00		
10kw/100amp Model Number 7172 16 Circuit	\$4119.00		
7.5kw/ 50amp Model Number 6998 8 Circuit	\$2169.00		
Custom Generator:			
Custom Transfer Switch: <u>LP Regulator</u>		1	350
Custom: <u>Permit</u>		1	300
Custom: <u>E-Stop</u>		1	300
Substitute 100amp Service Entrance RXSW100A3 for 200amp Prepackaged Switch	\$0.00		
Basic Labor and Material (26kw)			\$4450.00
Basic Labor and Material (7.5kw - 24kw)		1	\$4250.00
Other Labor and Material <input type="checkbox"/> Extra Electric \$ _____ <input type="checkbox"/> Extra Gas \$ _____ <input type="checkbox"/> Underground Electric \$ _____ <input type="checkbox"/> Underground Gas \$ _____			
Cold Weather Kit (Battery Warmer and Oil Warmer)		1	\$425.00
Preformed Concrete Pad		1	\$375.00
Battery Installed		1	\$175.00
CO Detector Installed		1	\$49.00
Surge Protector Installed			\$300.00
Fleet 1 Year Monitoring Subscription	\$100.00		
WiFi Setup	\$89.00		
Battery Backup	\$95.00		
Mobile Link Installed <input type="checkbox"/> Cellular Mobile Link	\$475.00	1	475
<input type="checkbox"/> Cellular Mobile Link Yearly Subscription <u>OPTIONAL</u>	\$100.00	1	100
PSP SMM60	\$425.00		
Extra Trip Charge/Delivery	\$300.00		
Maintenance Agreement <input type="checkbox"/> 1 Year \$275.00 <input type="checkbox"/> 3 Year \$825.00		1	275
5 Year Limited - Standard Factory Warranty	\$0.00		
5 Year Extended Warranty <u>Vice Power Play</u>	\$450.00	1	0
7 Year Extended Warranty	\$750.00		
10 Year Extended Warranty	\$995.00		
Warranty/Promotion:			

SUBTOTAL 14,183

Finance: Synchrony: _____ Other: _____

Military Discount: 3% Off of Generator

Customer Signature: _____ Cash or Check Discount: 3% Off of Generator

Date: _____ Custom: _____

Sales Tax T.E.

TOTAL 14,183



Name: Monroe Fire Station 26

- Natural Gas
- New Service: If gas company and/or customer sets gas service away from a specified location, additional charges may apply.
Specified Location: _____

MGS recommendations are only recommendations. Gas company will make final determination. It is the customer's responsibility to verify with gas company. All fees associated with gas meter upgrade or pressure increase are customer's responsibility. Center Point Energy: 800-990-1930 • Citizen's: 317-924-3311

Customer Gas Meter Size: _____ to _____

- Upgrade Gas Meter Upgrade Gas Pressure
- Existing Water Column or Pressure: _____ Required Water Column or Pressure: _____

- Existing BTU: _____
Furnace: _____ Water Heater: _____ Stove: _____
Clothes Dryer: _____ Pool Heater: _____ Fireplace: _____
Other: _____
- New BTU: _____ Generator: _____ Total BTU: _____

- Propane
MGS recommends a minimum 500 gallon propane tank:
 - Customer is responsible for setting appointment and coordination with propane company. Install Date: _____
 - Gas must arrive before generator is set or on the day of installation before 12 PM. Propane companies are not allowed to start MGS installed generators. A fee of **\$75.00** will be assessed to the customer for return trip to start and test unit if propane is not available on the day of the install.
- Propane Line and Regulator to be supplied by gas company.
- Propane Line and Regulator to be supplied by MGS.

- MGS will call 811 Locate for all utility company lines.
(Utility: Natural Gas, Electric, Fiber, Cable, Phone, City-Connected Sewer, City-Connected Water)
 - Customer is responsible to contact propane company to mark propane lines. Initial: _____
 - Customer is responsible to locate any other utility lines. Initial: _____
(Sprinkler Lines, Electrical Wires, Septic Lines, Cable Lines, DISH, Direct TV, Well, Septic, Sump Pump, etc.)
- If customer declines to have private locate completed, additional charges will apply for repair of underground lines.
Initial: _____

Customer is responsible for: _____

Generator Location: At least 18' off building
Between regulator and electric meter
At least 5' from regulator

Customer Signature: _____ MGS Signature: J. Reynolds
Date: _____ Date: 1-21-26

Monroe Fire Protection District Investment / CD Competitive Quotes

- Summary of CD investment quotes from local/regional banks, credit unions, and national banks.
- The Board of Trustees would like to review options for investing public funds currently held in savings accounts earning a variable interest rate of 2.02%. The business rate has been dropping over the last 18 months from 2.9%.
- The State Board of Accounts allows us to invest public funds for periods of time when the funds are not needed to fulfill the budgetary and operational obligations. <https://iga.in.gov/laws/2024/ic/titles/5#5-13-9>

Key Financial Concepts

- Simple Interest Rate vs Annual Percentage Yield (APY)
 - APY formula: $APY = (1 + r/n)^n - 1$
- All institutions contacted will compound daily and post interest earnings quarterly.
- Most publicize penalties for early withdrawal in the first 3-6 months. Local/Regional banks may waive the fee.
- Regional and National banks are Federally insured through FDIC up to \$250,000.
- The Public Deposit Insurance Fund (PDIF) is an Indiana program providing an additional layer of protection for deposits of public funds by government entities to cover 100% of the remaining funds exceeding \$250,000.

Overview by Institution Type

Institution	Term	Rate / APY	Notes
Local / Regional Banks	5–12 Months	~3.5% – 4.0%	Covered by **Federal Deposit Insurance Corporation + Indiana Public Deposit Insurance Fund
Credit Unions	6–7 Months	~3.0% – 4.5%	Up to \$250k Insured by **National Credit Union Administration
National Banks	4–6 Months	~3.0% – 3.25%	Lower rates currently offered
Investment Pool	Variable	~3.6%	**TrustIndiana Local Government Investment Pool

Local & Regional Banks

<u>Local/Regional</u>	Short term CDs				12-month or longer CDs				
		Compounded	APY	Net from Current	Term	APY	Net from Current	Principle	
The People's State Bank	6-month				12-month				
601 E Temperance St, Ellettsville	3.59%	Daily	3.65%	\$11,700	4.00%	4.08%	\$ 30,911.57	\$1.5M	
							\$ 20,608.00	\$1.0M	
Old National Bank					12-month				
300 E Kirkwood Av, Bloomington		Daily				3.94%	\$ 28,800.00	\$1.5M	
German American	5-month				12-month				
504 N College, Bloomington	3.70%	Daily	3.75%	\$10,449		3.65%		\$1.5M	
JCBank (Jackson County Bank)					12-Month				
1280 N College Av St4, Bloomington					3.90%	4.05	\$ 29,850.00		
Union Savings	5-month								
2237 S Curry Pike, Bloomington	4.50%	Daily	4.43%	\$14,786					

Credit Union Options

	Short term CDs			12-month or longer CDs		
<u>Credit Unions</u>						
Crane Credit Union NCUA & PDIF	7-month			13-month		
1201 James Av, Bloomington	4.04%			3.74%	\$	27,969.00
Hoosier Hills Credit Union						
630 Lincoln Av, Bedford No return call						
IU Credit Union	6-month			13-month	APY	
No FDIC or PDIF	Daily	4.50%	\$20,827		4.25%	

National Bank Options

		Short term CDs			12-month or longer CDs		
<u>National Banks</u>							
5th/3rd Bank	5-month						
200 S Washington St, Bloomington	3.25%						
Chase Bank	4-month				14-month		
100 S College Av, Bloomington	3%				2.75%		

Other Investment Option

- Trust Indiana – Indiana Local Government Investment Pool (LGIP)
 - Variable rate ~3.62%. Follows the Federal Rates & expected to drop another .5% this year.
 - Invested ~50% in banks and 50% in Treasury bills / short-term securities. Partially insured.
 - Third-party administrator. Flexible and Liquid. Bank transfers by ACH

<u>Trust Indiana</u>		Variable Rate
IN State Investment Pool - Trust IN	Daily	3.62%
Indiana Local Govt Investment Pool		
(LGIP) IN Treasurer of State		
50% in Banks/50% in Treasury Bills and Short Term Loans		

Key Takeaways

- Distributing the public funds currently held in Savings Accounts into one or more CD account will likely increase our interest revenue based on market expectations.
- A 12-month CD will guarantee a yield much higher than our current business interest rate.
- Short term CD options (3-5 months) may be a good investment each time tax settlements are distributed.



March 31, 2026

Nick Powell
Fleet Manager
Monroe Fire Protection District
2123 S. Kirby Rd.
Bloomington, IN 47403

RE: HME Pumper Offer

Dear Fleet Manager Powell,

We hereby propose and agree to furnish, after your acceptance and both parties accepting the appropriate HME Sales Agreement, the following apparatus:

HME Ahrens-Fox 1871 Pumper: \$1,038,500.00

One (1) HME Ahrens-Fox Pumper on HME 1871 Custom Four Door Cab & Chassis, equipped as shown in attached specifications, with standard HME 3 year warranty. Unit includes Cummins L9 engine, stainless steel body, black out package, booster reel and one EMS compartment in the cab. Lettering and delivery are also included.

HME offers a 1 year build time from the time an HME Sales Agreement is signed and executed by an officer of the District and an officer of HME. If this order is placed prior to April 10th, HME can include the Cummins L9 engine in the build. Any orders placed after that will be subject to the new Cummins X10 engine with an associated price increase. HME cannot be held liable for penalties and/or delays due to strikes, failures to obtain materials, fires, accidents, force majeure, or any other causes beyond the Company's control.

The amount named in this proposal shall remain firm for a period of 30 days from the date of same, with the exception that an allowance for a change in engines may be required if an order is placed after April 10th. All state, federal and local taxes are not included above. Any applicable taxes are to be paid by customer upon registration and licensing of vehicle. It is understood by both the Seller and the Buyer that Change Orders executed after contract acceptance will delay delivery. It is understood by both the buyer and the seller that Change Orders executed after contract acceptance may increase or decrease the price. The purchase price herein is based upon all applicable state and federal manufacturing law,



911 Fleet & Fire Equipment

11 Lendale Dr.
Florence, KY 41042
P: (877) 605-2378
F: (859) 371-0131

regulations, orders, mandates and standards in effect as of the date of this Agreement (hereinafter "Standards") such as, for example, the Standards mandated by the National Fire Protection Association, tentative interim amendments to the National Fire Protection Association Standard, Underwriters Laboratories of Canada, and the US Environmental Protection Agency. The purchase price shall be subject to increase due to any state or federal Standards that are adopted, issued or mandated following the date of this Agreement that require the apparatus(es) described above to be manufactured and/or delivered in compliance with such Standard(s)

All checks must be made payable to HME, Incorporated only and delivered to HME, Incorporated at its offices in Wyoming, Michigan. Under no circumstances shall payment be made to a dealer or anyone else as Sellers agent. HME, Incorporated is the only authorized payee. Any representation that payment is to be made to any other party is absolutely unauthorized.

Official ownership documents shall remain property of the seller until the purchase price is paid in full. Upon receipt of payment, ownership documents shall be forwarded to the purchaser.

Any warranty service would be performed by 911 Fleet and Fire Equipment, located in Florence, KY.

We appreciate the opportunity to submit this proposal, please let us know if you have any questions.

Respectfully submitted,

911 Fleet and Fire Equipment

Andrew Barnard

Date: 3/31/2026

We agree to accept the above proposal:

Monroe Fire Protection District

Date: ____/____/____





Monroe Fire Protection District



To: Board of Trustees, Monroe Fire Protection District

From: Nicholas Powell

Date: 4/1/2026

Subject: Advisory Regarding Fire Engine Replacement and HME Apparatus Recommendation

The purpose of this letter is to advise the Board of Trustees regarding the necessary replacement of our current fire apparatus. We began exploring these options due to our aging frontline fleet; while three of our newest trucks are 2018, 2019, and 2022 models, the remainder of the fleet consists of units from 2015 and older. These aging units have become a significant maintenance burden, with some apparatus recently requiring complex wiring repairs and full in-chassis engine overhauls to remain operational.

After months of intensive research, we have identified a replacement that meets all operational requirements of the District and offers the best long-term value. While this letter is not a formal request for purchase, it serves to advise the Board that a purchase is becoming critical to maintain our service standards and to highlight market factors that will impact our budget if action is not taken soon.

Recommendation: HME Ahrens-Fox 1871 Pumper Following our evaluation, we recommend the HME Ahrens-Fox 1871 Pumper with the 74S body. This apparatus, priced at \$1,038,500.00, specifically meets our department's requirements for the following reasons:

- **Warranty:** HME offers a comprehensive 3-year standard warranty on the unit.
- **Engine Specifications:** The proposed unit is equipped with the current, proven Cummins L9 engine.
- **Non-Proprietary Parts:** A key requirement for our District is the use of commercially sourced, non-proprietary parts. This ensures we can maintain the vehicle through multiple service providers and are not "locked in" to a single manufacturer for specialized components.
- **Serviceable Design:** HME incorporates a **bolted-together body design**. Unlike welded structures, this allows for individual body panels to be easily replaced if damaged, significantly reducing repair costs and downtime over the life of the truck.

**HEADQUARTERS
3953 S KENNEDY DRIVE
BLOOMINGTON IN
812-331-1906
812-336-1166 (FAX)**

- **Delivery Timeline:** While many manufacturers are seeing extreme delays, HME can deliver this unit in approximately one year.

Critical Timing and Market Factors We must bring to the Board’s attention a looming industry-wide change regarding engine manufacturing. Manufacturers will be required to implement the new Cummins X10 engine to meet new emission regulations.

- **Market-Wide Cost Impact:** This is not exclusive to one vendor; all major manufacturers are incorporating this price increase. We have received confirmation from **Rosenbauer and Seagrave** that they are also implementing this change.
- **Cost Efficiency:** Transitioning to the X10 engine will result in an approximately \$80,000.00 price increase. By securing a build with the current L9 engine, we can avoid this surge and instead allocate those funds toward outfitting the new engine with necessary loose equipment and tools.
- **Design Risks:** The X10 is a completely new design with new emission regulations. As with any first-generation engine, it represents an "unknown" in terms of long-term reliability and maintenance costs compared to the proven Cummins L9.

Comparative Research and Manufacturer Concerns Our research included a review of quotes from other major manufacturers, including Sutphen and Rosenbauer (Sentinel). We specifically looked at HME due to challenges faced with the REV Group umbrella and other manufacturers who utilize proprietary designs. Even among brands not owned by REV Group, proprietary items remain a concern for our maintenance budget.

Due to documented issues regarding numerous lawsuits, the high price of proprietary parts, and the long wait times for repairs associated with REV Group manufactured apparatus, we recommend remaining independent of their products. HME remains a 100% American-owned company that aligns with our preference for transparency and serviceability.

Summary The HME Ahrens-Fox 1871 Pumper is the ideal fit for the Monroe Fire Protection District. By moving forward before the April 10th deadline, we can secure a proven engine, a more serviceable bolted body design, and avoid a significant price escalation—allowing us to use those funds for essential equipment rather than an unproven engine design.

I have attached the detailed HME (911 Fleet and Fire) proposal, specifications, and engineering drawings for your review. I am available to discuss these findings at your convenience.

Respectfully,

Nicholas Powell

Fleet Manager

Monroe Fire Protection District

THIS DRAWING IS AN OVERALL REPRESENTATION OF THE APPARATUS AS PROPOSED.
 THE EXACT DIMENSIONS, LOCATIONS OF ACCESSORIES AND/OR COMPONENTS MAY BE REVISED PENDING COMPLETE ENGINEERING OF THE CUSTOM REQUIREMENTS OF THE INDIVIDUAL APPARATUS ORDER.
 IF THERE IS A DISCREPANCY BETWEEN THE BODY/BUILDER PRINT AND THE WRITTEN PROPOSAL, THE SPECIFICATIONS WITHIN THE PROPOSAL PREVAIL.

This drawing along with any changes made and initiated by both the "Fire Department" & HME, Inc. represents what will be constructed and supplied to the "Fire Department." Any changes to the contract specifications and drawing after today's date will be addressed via appropriate change order signed and approved by both the "Fire Department" & HME, Inc.

APPROVED BY: _____ TITLE: _____
 FIRE DEPARTMENT

APPROVED BY: _____ TITLE: _____
 HME, Incorporated

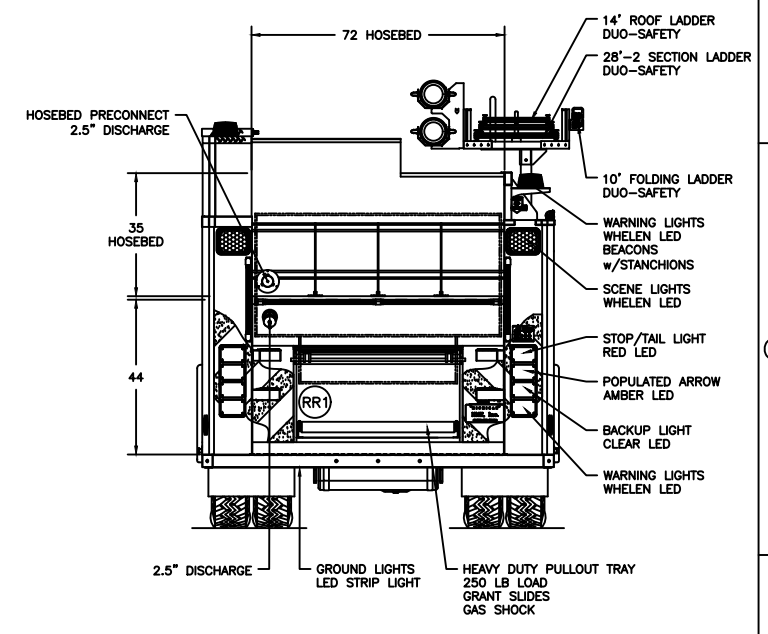
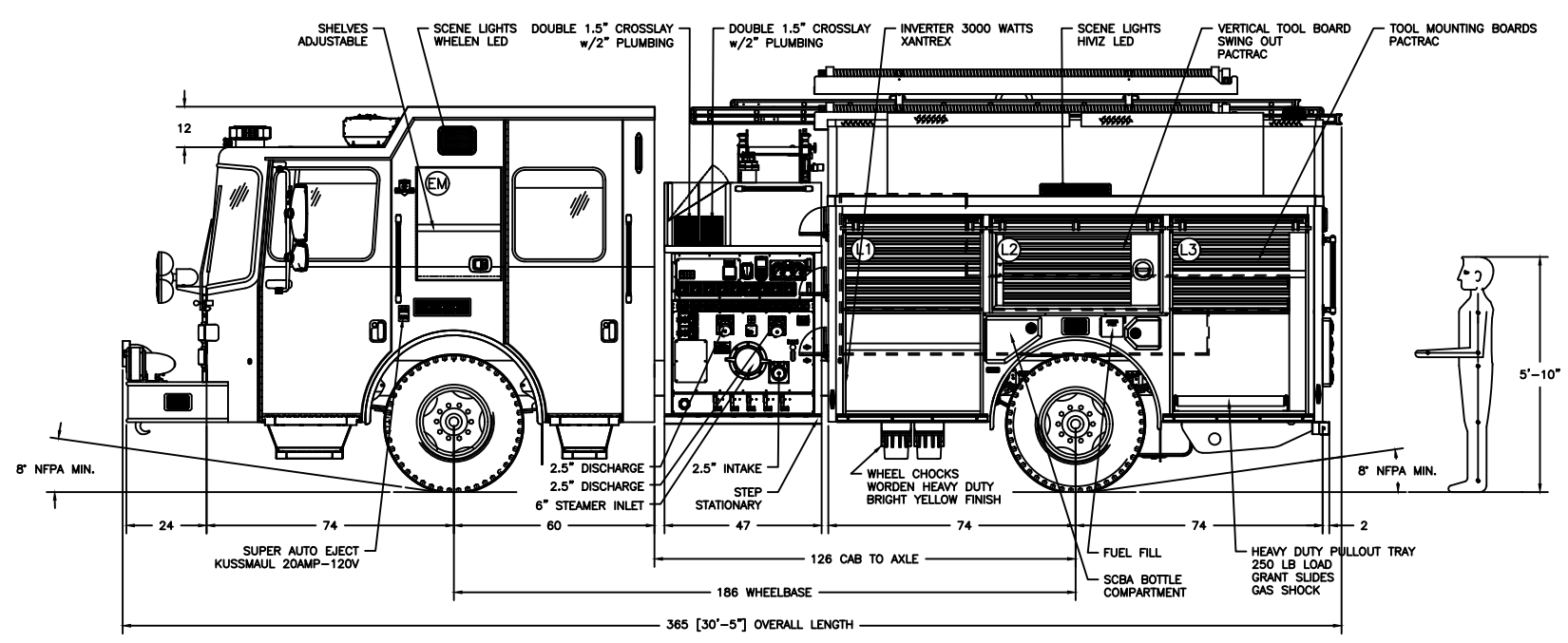
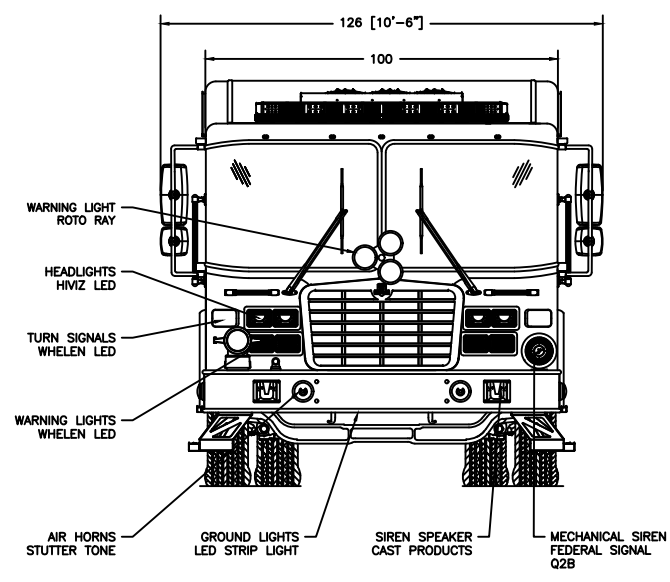
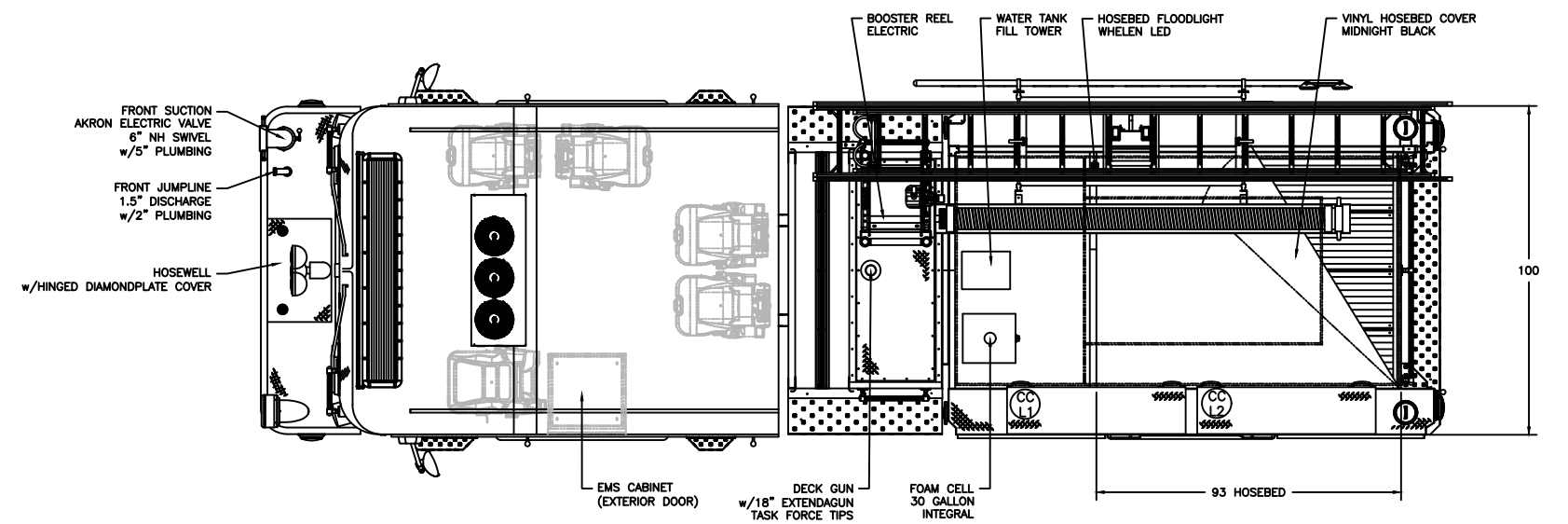

COMPARTMENTATION						
COMPT.	BEHIND DOOR			CLEAR OPENING		COMPT. VOLUME
	WIDTH	HEIGHT	DEPTH	DOOR WIDTH	DOOR HEIGHT	
L1 UPPER:	48"	33"	12"	39"	55"	11 FT ³
L1 LOWER:	48"	30"	24"	39"	55"	20 FT ³
L2:	52"	33"	12"	49 1/2"	24 1/2"	11.9 FT ³
L3 UPPER:	43"	33"	12"	39"	55"	9.9 FT ³
L3 LOWER:	43"	30"	24"	39"	55"	17.9 FT ³
R1 UPPER:	48"	33"	12"	39"	55"	11 FT ³
R1 LOWER:	48"	30"	24"	39"	55"	20 FT ³
R2:	52"	33"	12"	49 1/2"	24 1/2"	11.9 FT ³
R3 UPPER:	43"	33"	12"	39"	55"	9.9 FT ³
R3 LOWER:	43"	30"	24"	39"	55"	17.9 FT ³
CCR1:	112"	12"	24"	54 1/2"	11 1/2"	18.7 FT ³
CCR2:				54 1/2"	11 1/2"	
RR1:	48"	29"	22"	45 1/2"	20 1/2"	17.7 FT ³

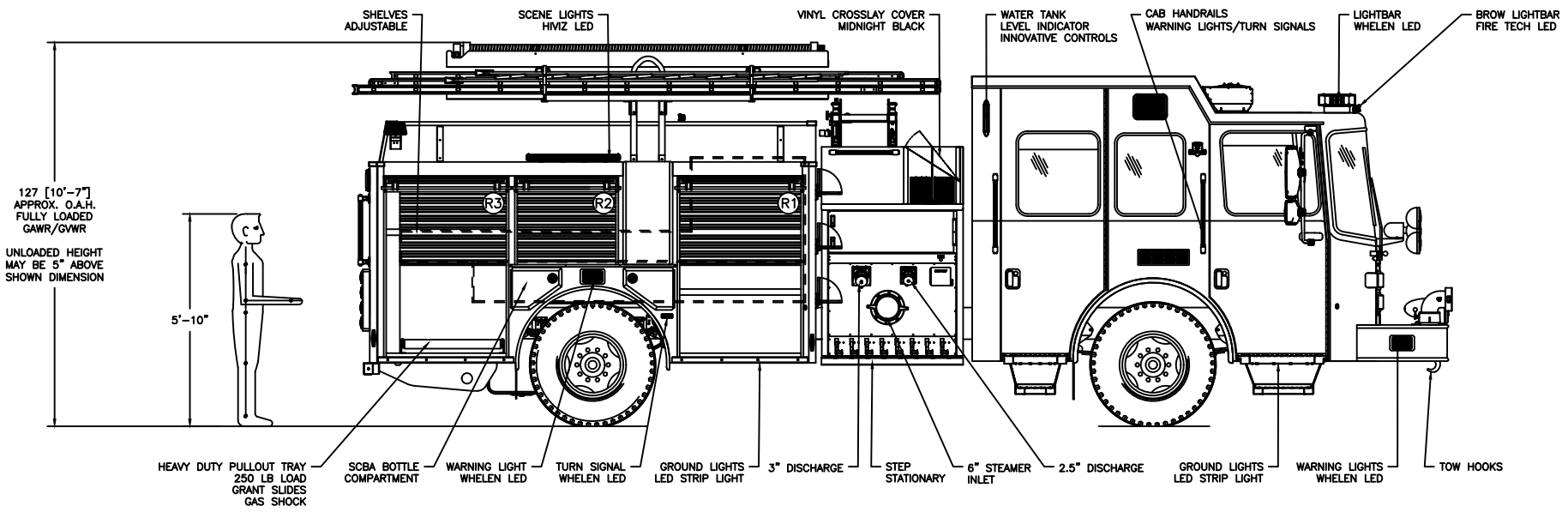

A	A.C.	30 MAR '26	ORIGINAL RELEASE
LET	BY	DATE	REVISION

**1950 BYRON CENTER AVE.
 WYOMING, MI. 49519**

THIS PRINT IS PROVIDED ON A RESTRICTED BASIS AND IS NOT TO BE USED IN ANY WAY DETRIMENTAL TO THE INTERESTS OF HME, INC.

NAME
MONROE FIRE PROTECTION DISTRICT - BLOOMINGTON, IN

DRAWN A. CHAKRAVORTY	DATE 26 MAR '26	APPROVED N/A	DRAWING FILE MONROE FIRE PROTECTION DISTRICT - BLOOMINGTON, IN - 15719 SW PASADENA
THIRD ANGLE PROJECTION	SIZE B	NUMBER BLOOMINGTON, IN	SCALE NTS SHEET 1 OF 1



PROPOSAL

TO THE:

Monroe Fire Protection District
Attn: Nick Powell – Fleet Manager
285 E. Rhorer Road
Bloomington, Indiana 47401

DATE: August 15th, 2025

We hereby propose and agree to furnish the following firefighting equipment upon your acceptance of this Proposal:

**One (1) Sutphen Heavy Duty Custom Pumper HS-8213 Complete and Delivered
for the Total Sum of \$941,315.24**

The apparatus and equipment being purchased hereunder shall be delivered **AS IS** approximately three (3) months after the Sutphen's receipt and approval of Purchaser's acceptance of this Proposal. Additions to the apparatus requested and approved by the Fire Protection District may lengthen the delivery time. The apparatus must be paid in full to Sutphen Corporation prior to any additions.

This Proposal shall be valid for thirty (30) days however it is being offered on a **first come, first served basis**. A letter of intent to purchase will hold the apparatus for the Fire Protection District for a period of 14 days to allow for the execution of a Purchase Agreement. If a Purchase Agreement or Purchase Order is not received by Sutphen within 30 days of the date of this Proposal, Sutphen reserves the right to extend, withdraw, or modify this Proposal, including pricing, delivery times, and prepayment discounts, as applicable.

Respectfully submitted,

Jason Frankle
Heritage Fire Equipment
Authorized Representative, Sutphen Corporation



Proposal for Apparatus

Monroe Fire Protection District
3953 S. Kennedy Dr,
Bloomington, Indiana 47401

03/24/2026

Your requirements have been carefully reviewed by our engineering and sales staff. The following proposal meets the intent and technical requirements of your specifications. Minor exceptions or clarifications, if taken, are noted separately herein.

Our proposal meets 100% the intent and technical requirements of your specifications. The proposed apparatus we propose to furnish shall be manufactured in accordance with the enclosed specifications after proper executions of consortium purchasing agreement or contract.

One (1) Rosenbauer Pumper Mounted on a Commander Chassis

Total Price: \$995,000.00

The price listed above includes delivery and orientation on the apparatus.

DELIVERY: Approximately 390 calendar days after receipt of order. Chassis availability will determine the exact completion date.

PREPAYMENT DISCOUNTS: Chassis and prepay options are available.

INSPECTION TRIPS: The following inspection trips are included in the quoted price.

- Preconstruction - Sentinel Emergency Solutions
- Mid-Point – Optional
- Final Inspection - Rosenbauer MN for (3) department members
- Shelving- \$50,000 custom shelving allowance is included with proposal price.

TERMS: Payment is due upon arrival at Sentinel Emergency Solutions.

Respectfully Submitted,

David Vehslage

David Vehslage
Authorized Distributor for Rosenbauer

South Dakota Division
100 Third Street
PO Box 57
Lyons, SD 57041

Minnesota Division
5181 260th Street
Wyoming, MN 55092

Aerial Division
870 South Broad Street
Fremont, NE 68025



Proposal for Apparatus

Monroe Fire Protection District
3953 S. Kennedy Dr,
Bloomington, Indiana 47401

04/02/2026

Your requirements have been carefully reviewed by our engineering and sales staff. The following proposal meets the intent and technical requirements of your specifications. Minor exceptions or clarifications, if taken, are noted separately herein.

Our proposal meets 100% the intent and technical requirements of your specifications. The proposed apparatus we propose to furnish shall be manufactured in accordance with the enclosed specifications after proper executions of consortium purchasing agreement or contract.

One (1) Rosenbauer Pumper Mounted on a Commander Chassis Stock Truck #16245

Total Price: \$1,043,500.00

The price listed above includes delivery and orientation on the apparatus.

DELIVERY: Approximately 390 calendar days after receipt of order. Chassis availability will determine the exact completion date.

PREPAYMENT DISCOUNTS: Chassis and prepay options are available.

INSPECTION TRIPS: The following inspection trips are included in the quoted price.

- Preconstruction - Sentinel Emergency Solutions
- Mid-Point – Optional
- Final Inspection - Rosenbauer MN for (3) department members
- Shelving- \$40,000 custom shelving allowance is included with proposal price.

TERMS: Payment is due upon arrival at Sentinel Emergency Solutions.

Respectfully Submitted,

David Vehslage

David Vehslage
Authorized Distributor for Rosenbauer

South Dakota Division
100 Third Street
PO Box 57
Lyons, SD 57041

Minnesota Division
5181 260th Street
Wyoming, MN 55092

Aerial Division
870 South Broad Street
Fremont, NE 68025



Monroe Fire Protection District



Proposal for New Lawn Mower Purchase: Station 21

Overview

To ensure the efficient maintenance of our facility grounds and maintain the professional appearance of Station 21, I respectfully submit this proposal for the purchase of a new **Hustler Fastrak 60-inch Zero-Turn Mower**. Our current equipment has reached the end of its reliable service life, and a replacement is necessary to avoid increasing repair costs and operational downtime. The total cost for this acquisition is **\$7,499.29**, which includes a comprehensive 3-year/300-hour warranty.

1. Equipment Coverage

This proposal covers the procurement of a professional-grade mowing unit to be stationed at Station 21:

- **New Unit:** Hustler Fastrak 60-inch Zero-Turn Mower.
- **Protection:** 4-Year / 750-Hour Limited Warranty.

2. Service Protocol

The selected Hustler unit is designed for heavy-duty residential and commercial applications. The transition to a 60-inch deck from our previous 72-inch model provides a strategic balance between cutting speed and maneuverability around station obstacles, without sacrificing significant efficiency.

3. Scope of Replacement

This purchase serves as a direct replacement for the aging equipment currently in service:

Current Equipment Status:

- **Model:** 2001 Toro 72-inch Mower.

HEADQUARTERS
3953 S KENNEDY DRIVE
BLOOMINGTON IN
812-331-1906
812-336-1166 (FAX)

- **Usage:** 1,338.7 Hours.
- **Condition:** Beyond economical repair; the 25-year-old chassis and engine components no longer meet the reliability standards required for station maintenance.

Key Features of New Equipment:

- **Precision Cutting:** 60-inch heavy-duty fabricated deck.
- **Operational Efficiency:** Zero-turn technology to reduce mowing time and physical strain on personnel.
- **Long-term Reliability:** Modern fuel efficiency and a robust warranty to minimize out-of-pocket maintenance costs for the next three years.

4. Cost Summary and Competitive Bidding

A market analysis was conducted to ensure the most fiscally responsible use of funds. The Hustler Fastrak represents a significant cost saving of over **\$5,100** compared to the next closest bid.

Item	Description	Cost
Hustler Fastrak	60" Deck w/ 3-Year Warranty	\$7,499.29
Competitor Bid A	60" Mower (Alternative Brand)	\$12,600.00
Competitor Bid B	72" Mower (Alternative Brand)	\$14,399.00
Total Investment		\$7,499.29

Justification

The 2001 Toro mower has served Station 21 for nearly a quarter-century. With over 1,300 hours of use, the mechanical integrity of the unit is compromised, leading to frequent breakdowns and the unavailability of vintage replacement parts.

By selecting the Hustler Fastrak, we are opting for a high-performance machine at a fraction of the cost of other commercial bids. The inclusion of a **3-year/300-hour warranty** ensures that the

department is protected from unforeseen mechanical expenses, allowing for a predictable budget and well-maintained station grounds.

Conclusion

The purchase of the Hustler Fastrak 60-inch mower is the most cost-effective solution to address the failing equipment at Station 21. It provides a modern, reliable, and warranted machine at a price point well below current market alternatives. I respectfully request approval for this purchase at a total cost of **\$7,499.29**.

Q U O T A T I O N

PAGE: 1

RICHARD'S SMALL ENGINE INC
8273 W. ST. RD 46
ELLETTSVILLE, IN 47429 USA
Phone #: (812)876-9302

PHONE #: (812)331-1906
CELL #: (812)322-6161
ALT. #: (812)381-1022 Ext: NICK
P.O.#:
TERMS: Net 30
SALES TYPE: Quote

DATE: 3/25/2026
ORDER #: 304240
CUSTOMER #: 21662
CP: KEVIN M
LOCATION: 1
STATUS: Active

BILL TO 21662

MONROE FIRE PROTECTION DISTRICT
FORMERLY PERRY CLEAR CREEK FIRE DEPT
2123 S KIRBY RD
BLOOMINGTON, IN 47403 USA

SHIP TO

MONROE FIRE PROTECTION DISTRICT
FORMERLY PERRY CLEAR CREEK FIRE
DEPT
2123 S KIRBY RD
BLOOMINGTON, IN 47403 USA

MFR	PRODUCT NUMBER	DESCRIPTION	QTY	PRICE	NET	TOTAL
EXC	941740	KAWASAKI FT730 (24hp) 60" FASTRAK	1	\$9,499.00	\$7,499.29	\$7,499.29
MISC	BID ASSISTANCE	BID ASSISTANCE	1	\$0.00	\$0.00	\$0.00

Prices reflected on this quote are valid for 7 days.

SUBTOTAL: \$7,499.29
TAX: \$0.00

ORDER TOTAL: \$7,499.29

Authorized By: _____

Wagler Small Engine LLC

6832 E. 280 N.
Montgomery, IN. 47558

Estimate

Date	Estimate #
3/9/2026	233

Name / Address
Mark Mahurin. 1125 W. Popcorn Rd. Bloomington, IN. 47403

			Project
Description	Qty	Cost	Total
Ferris ISX3300 40 HP Vanguard EFI ETC OGS, 72" Deck		17,200.00	17,200.00
Ferris ISX2200 60" 28HP Vanguard EFI OGS		12,600.00	12,600.00
Ferris ISX2200 60" 30.5 Kawasaki EVO EFI		13,500.00	13,500.00
		Total	\$13,300.00

Customer Signature _____

FD



Air Works III LLC
 6773E 750N
 Odon, IN 47562
 Phone: (812) 687-7337
 Fax: (812) 687-7735
 richard@airworkssales.com

PROPOSAL

Proposal ID	Date
10030	3/12/2026
Sales Person	Page
RICHARD	1 of 1

Proposal To:

MONROE FIRE PROTECTION DISTRICT
 285 E Rhorer Road
 Bloomington, IN 47401

Phone: (812) 360-6358
 E-Mail: npowell@monroefd.org

Ship To:

Pickup

Decision Maker	Ship Date	Ship Via	Description	Terms	
		Pickup	CHEETAH 61"V - 38FX-EFI KAWASAKI AIRLESS TIRES	Net 30 days	
Quantity	Product ID		Description	Unit Price	Amount
1.00	SCZS-61V-38FXE-NFT		CHEETAH 61"V - 38FX-EFI KAWASAKI AIRLESS TIRES	14,799.00	14,799.00
1.00	SCZII-72V-38FX-EFI		CHEETAH II - 72" - 38hp Kawasaki FX-EFI	14,399.00	14,399.00

BID ASSIST

ACCEPTANCE OF PROPOSAL

The above prices, specifications, and conditions are satisfactory and are hereby accepted.
Proposal is valid until Tuesday, March 17, 2026

Signature _____
 Date _____

Subtotal	29,198.00
Sales Tax	Exempt
TOTAL	29,198.00

Monroe Fire Protection District Claims Signed - March, 2026

Vendor	Amount	Account Description	Description	Date Paid	Check #	Account	
						Line	Fund
911 Fleet & Fire Equipment	\$ 1,018.26	PPE	Eagle Air Mens Shoes Qty 2	3/4/2026	1960	8781	Cum Fund 8691
911 Fleet & Fire Equipment	\$ 800.00	Misc; Equipment	Seek Thermal FQ PAEX	3/4/2026	1960	8780	Cum Fund 8691
MES- MES Service Company, LLC	\$ 609.66	PPE	Gauntlet Glove	3/4/2026	1959	8781	Cum Fund 8691
Hoosier Drywall Specialists	\$ 3,330.00	Building Renovations	Station 25	3/26/2026	1961	8784	Cum Fund 8691
Vanhorn Tint & Accessories	\$ 1,300.00	Small Vehicles	Brush Truck Graphics	3/31/2026	1962	8779	Cum Fund 8691
Total Cum Fund Spend	\$ 7,057.92						
PSB-Elan Financial Services	\$ 500.75	Meals & Awards	Meals & Awards	3/10/2026	EFT	8440	Donation Fund 8840
Total Donation Fund Spend	\$ 500.75						
911 Fleet & Fire Equipment	\$ 92.52	Vehicle/Eq Mnt	Streamlight	3/10/2026	10791	8302	General Fund 8603
911 Fleet & Fire Equipment	\$ 58.00	Vehicle/Eq Mnt	Seek Thermal	3/26/2026	10818	8302	General Fund 8603
AFLAC	\$ 5,621.14	Voluntary AFLAC	Employee withholding	3/10/2026	EFT	3098	General Fund 8603
Amazon Capital Services	\$ 347.81	Computer Support	Memory Card Qty 3, Outdoor Electric Box Qty 3, misc	3/4/2026	10781	8354	General Fund 8603
Amazon Capital Services	\$ 185.21	Vehicle/Eq Mnt	Junction Box	3/4/2026	10781	8302	General Fund 8603
Amazon Capital Services	\$ 110.03	Operating Supplies	work gloves, knee pads, safety glasses	3/4/2026	10781	8301	General Fund 8603
Amazon Capital Services	\$ 104.95	Computer Support	Rugged Tablet	3/4/2026	10781	8354	General Fund 8603
Amazon Capital Services	\$ 97.56	Office Supplies	Collage Picture Frame, Wall Anchors	3/4/2026	10781	8300	General Fund 8603
Amazon Capital Services	\$ 69.88	Vehicle/Eq Mnt	Oil Change Kit	3/4/2026	10781	8302	General Fund 8603
Amazon Capital Services	\$ 49.99	Operating Supplies	Hot water faucet	3/4/2026	10781	8301	General Fund 8603
Amazon Capital Services	\$ 41.49	Vehicle/Eq Mnt	Oil	3/4/2026	10781	8302	General Fund 8603
Amazon Capital Services	\$ 28.57	Vehicle/Eq Mnt	Lower Door Mirror Bracket	3/4/2026	10781	8302	General Fund 8603
Amazon Capital Services	\$ 9.99	Vehicle/Eq Mnt	Stainless Steel Footman Loop	3/4/2026	10781	8302	General Fund 8603
Amazon Capital Services	\$ 9.59	Vehicle/Eq Mnt	Security Alarm Door Window	3/10/2026	10792	8302	General Fund 8603
Amazon Capital Services	\$ 93.62	Operating Supplies	Pro Water Hose	3/10/2026	10792	8301	General Fund 8603
Amazon Capital Services	\$ 140.51	Vehicle/Eq Mnt	Car Wax, Interior cleaner, Floor Mats	3/10/2026	10792	8302	General Fund 8603
Amazon Capital Services	\$ 527.87	Operating Supplies	Fire Extinguisher Tags, Lamps, other	3/10/2026	10792	8301	General Fund 8603
Amazon Capital Services	\$ 6.39	Operating Supplies	Closet Dividers	3/17/2026	10808	8301	General Fund 8603
Amazon Capital Services	\$ 118.32	Computer Support	Laptop Chargers, Mounting Tape, Charging station	3/17/2026	10808	8354	General Fund 8603
Amazon Capital Services	\$ 56.56	Office Supplies	Stick Pens, Sharpies, Lined Paper	3/17/2026	10808	8300	General Fund 8603
Amazon Capital Services	\$ 169.90	Operating Supplies	Milwaukee M18 1/2" drill/driver set	3/17/2026	10808	8301	General Fund 8603
Amazon Capital Services	\$ 251.60	Operating Supplies	Fusion Climb Bent Gate Carabiner	3/17/2026	10808	8301	General Fund 8603
Amazon Capital Services	\$ 275.40	Operating Supplies	Laptop Backpack (10)	3/17/2026	10808	8301	General Fund 8603
Amazon Capital Services	\$ 77.58	Operating Supplies	Ghost Controls	3/26/2026	10819	8301	General Fund 8603
Amazon Capital Services	\$ 96.29	Office Supplies	Toner	3/26/2026	10819	8300	General Fund 8603
Amazon Capital Services	\$ 475.79	Office Supplies	Toner	3/26/2026	10819	8300	General Fund 8603
Amazon Capital Services	\$ 349.00	Operating Supplies	Annual Membership	3/26/2026	10819	8301	General Fund 8603
Amazon Capital Services	\$ 15.83	Office Supplies	Parking Permit Holder	3/31/2026	10826	8300	General Fund 8603
Amazon Capital Services	\$ 513.84	Computer Support	IPS Monitor, HDMI Cable	3/31/2026	10826	8354	General Fund 8603
Amazon Capital Services	\$ 599.98	Operating Supplies	Robot Vacuum & Mop	3/31/2026	10826	8301	General Fund 8603
Anthem Blue Cross & Blue Shield	\$ 131,344.21	Health Insurance	Group Medical and Group Vision	3/4/2026	ATS	8243	General Fund 8603
Ascension St Vincent Public Safety Medical	\$ 1,605.59	Medical Services	Physical Bailey, Payne	3/10/2026	10793	8253	General Fund 8603
Ava's Waste Removal, Inc	\$ 96.00	Utilities	Station 26	3/4/2026	EFT	8550	General Fund 8603

Ava's Waste Removal, Inc	\$	96.00	Utilities	Station 24	3/4/2026	EFT	8550	General Fund 8603
Ava's Waste Removal, Inc	\$	55.00	Utilities	Station 23	3/17/2026	EFT	8550	General Fund 8603
Ava's Waste Removal, Inc	\$	65.00	Utilities	Station 21	3/17/2026	EFT	8550	General Fund 8603
Ava's Waste Removal, Inc	\$	75.00	Utilities	Station 22	3/17/2026	EFT	8550	General Fund 8603
Ava's Waste Removal, Inc	\$	75.00	Utilities	Station 29	3/17/2026	EFT	8550	General Fund 8603
Ava's Waste Removal, Inc	\$	65.00	Utilities	Station 39	3/17/2026	EFT	8550	General Fund 8603
Ava's Waste Removal, Inc	\$	75.00	Utilities	Station 25	3/17/2026	EFT	8550	General Fund 8603
Ava's Waste Removal, Inc	\$	30.00	Utilities	HQ	3/31/2026	EFT	8550	General Fund 8603
B & B Water Project	\$	269.24	Utilities	Station 24	3/10/2026	10794	8550	General Fund 8603
B & B Water Project	\$	261.84	Utilities	Station 24	3/31/2026	10827	8550	General Fund 8603
Black Lumber	\$	4.99	Operating Supplies	Screws	3/4/2026	10782	8301	General Fund 8603
Black Lumber	\$	13.56	Operating Supplies	Hardware	3/4/2026	10782	8301	General Fund 8603
Black Lumber	\$	7.59	Operating Supplies	Hanging Packages	3/31/2026	10828	8301	General Fund 8603
Bound Tree Medical, LLC	\$	203.19	EMS Supplies	LA Rescue 02 to Go Pro Plus	3/31/2026	10829	8304	General Fund 8603
Brian Stewart	\$	18.05	Training	Reimbursement Training	3/10/2026	10795	8351	General Fund 8603
Brian Stewart	\$	66.00	Training	Indy Park Reimbursement	3/10/2026	10795	8351	General Fund 8603
Bruce Garage & Home Improvements, Inc.	\$	1,920.00	Building Services	Replace 3 pair springs on door	3/31/2026	10830	8600	General Fund 8603
Capstone Insurance Group	\$	29,160.57	General Insurance	April Quarterly Inland Marine, Package, Umbrella	3/31/2026	EFT	8500	General Fund 8603
CenterPoint Energy (Formerly Vectren)	\$	213.95	Utilities	Sta 25 (address 5095)	3/10/2026	EFT	8550	General Fund 8603
CenterPoint Energy (Formerly Vectren)	\$	193.51	Utilities	Sta 24 bldg2	3/10/2026	EFT	8550	General Fund 8603
CenterPoint Energy (Formerly Vectren)	\$	368.07	Utilities	Sta 24	3/10/2026	EFT	8550	General Fund 8603
CenterPoint Energy (Formerly Vectren)	\$	621.40	Utilities	Sta 29	3/10/2026	EFT	8550	General Fund 8603
CenterPoint Energy (Formerly Vectren)	\$	726.25	Utilities	Sta 25 (address 5081)	3/10/2026	EFT	8550	General Fund 8603
CenterPoint Energy (Formerly Vectren)	\$	684.69	Utilities	Sta 21	3/10/2026	EFT	8550	General Fund 8603
CenterPoint Energy (Formerly Vectren)	\$	438.93	Utilities	Sta 22	3/10/2026	EFT	8550	General Fund 8603
CenterPoint Energy (Formerly Vectren)	\$	19.24	Utilities	HQ	3/10/2026	EFT	8550	General Fund 8603
Cincinnati Life Insurance Co	\$	63.10	Voluntary Cincinnati Life	Employee Withholding	3/31/2026	EFT	3097	General Fund 8603
Cincinnati Life Insurance Co	\$	681.30	Voluntary Cincinnati Life	Employee Withholding	3/31/2026	EFT	3097	General Fund 8603
Cincinnati Life Insurance Co	\$	1,638.84	Voluntary Cincinnati Life	Employee Withholding	3/31/2026	EFT	3097	General Fund 8603
City of Bloomington Utilities	\$	126.80	Utilities	Sta 29	3/10/2026	10796	8550	General Fund 8603
City of Bloomington Utilities	\$	54.36	Utilities	HQ	3/10/2026	10796	8550	General Fund 8603
City of Bloomington Utilities	\$	228.22	Utilities	Sta 22	3/10/2026	10796	8550	General Fund 8603
City of Bloomington Utilities	\$	13.45	Utilities	ABW	3/10/2026	10796	8550	General Fund 8603
Comcast Business	\$	1,200.65	Telephone / Data	District wide internet	3/4/2026	ATS	8400	General Fund 8603
David Ferguson - Atty	\$	2,365.00	Legal Counsel & Expenses	Background Checks (43)	3/17/2026	10810	8352	General Fund 8603
David Ferguson - Atty	\$	1,928.50	Legal Counsel & Expenses	February Services & Meeting	3/17/2026	10810	8352	General Fund 8603
Donley Safety	\$	1,287.75	Vehicle/Eq Mnt	Retainer Kit for H-45 LP; Quick Connect Adapter	3/26/2026	10817	8302	General Fund 8603
Dubois County Fire Trainer DCFTA	\$	350.00	Training	Ty Pride Training	3/4/2026	10783	8351	General Fund 8603
Dubois County Fire Trainer DCFTA	\$	1,500.00	Training	Drone - Silva, Instructor 1 - Kilar,Turner; MvMach Langley, Moore	3/31/2026	10831	8351	General Fund 8603
Duke Energy	\$	1,199.95	Utilities	Sta25	3/4/2026	ATS	8550	General Fund 8603
Duke Energy	\$	140.50	Utilities	Sta 25 (5095 1/2)	3/4/2026	ATS	8550	General Fund 8603
Duke Energy	\$	942.25	Utilities	Sta 21	3/4/2026	ATS	8550	General Fund 8603
Duke Energy	\$	519.28	Utilities	HQ	3/10/2026	ATS	8550	General Fund 8603
Duke Energy	\$	578.31	Utilities	Sta 22	3/10/2026	ATS	8550	General Fund 8603
EAN Services LLC - Enterprise	\$	345.70	Training	Training B Stewart	3/4/2026	10784	8351	General Fund 8603
Economy Termite & Pest Control, Inc.	\$	50.00	Building Services	pest control station 29	3/10/2026	10797	8600	General Fund 8603
Economy Termite & Pest Control, Inc.	\$	50.00	Building Services	pest control station 19	3/10/2026	10797	8600	General Fund 8603
Economy Termite & Pest Control, Inc.	\$	50.00	Building Services	pest control HQ	3/10/2026	10797	8600	General Fund 8603

Economy Termite & Pest Control, Inc.	\$	50.00	Building Services	pest control station 22	3/10/2026	10797	8600	General Fund 8603
Economy Termite & Pest Control, Inc.	\$	50.00	Building Services	pest control station 39	3/10/2026	10797	8600	General Fund 8603
Economy Termite & Pest Control, Inc.	\$	50.00	Building Services	pest control station 23	3/10/2026	10797	8600	General Fund 8603
Economy Termite & Pest Control, Inc.	\$	50.00	Building Services	pest control station 21	3/10/2026	10797	8600	General Fund 8603
Economy Termite & Pest Control, Inc.	\$	55.00	Building Services	pest control station 24	3/10/2026	10797	8600	General Fund 8603
Economy Termite & Pest Control, Inc.	\$	50.00	Building Services	ABW	3/10/2026	10797	8600	General Fund 8603
EVAPAR	\$	5,009.41	Building Services	Controller Power Zone Pro	3/10/2026	10798	8600	General Fund 8603
FirstNet - AT&T Mobility	\$	31.24	Telephone / Data	Wireless service - MDTs & Mobile	3/26/2026	EFT	8400	General Fund 8603
Fourwinds Lakeside and Marina	\$	540.86	Veh/Eq Repair	Service Marine	3/4/2026	10785	8605	General Fund 8603
Gibson Teldata Inc	\$	1,474.01	Telephone / Data	Phone System & Service	3/10/2026	EFT	8400	General Fund 8603
God is Sew Good, Inc	\$	40.00	Operating Supplies	Repair reflective coat and pants	3/26/2026	10821	8301	General Fund 8603
God is Sew Good, Inc	\$	24.00	Operating Supplies	Replace velcro on pockets	3/26/2026	10821	8301	General Fund 8603
God is Sew Good, Inc	\$	6.00	Operating Supplies	Repair hole in protection pants	3/26/2026	10821	8301	General Fund 8603
Grainger	\$	32.42	Vehicle/Eq Mnt	Pressure Switch	3/31/2026	10832	8302	General Fund 8603
Hoosier Fire Equipment Inc	\$	124.30	Vehicle/Equipment Mnt	Hale Gear Shift Switch & PVG Repair Kit	3/17/2026	10811	8302	General Fund 8603
J & S Locksmith	\$	29.00	Vehicle/Eq Mnt	Chain 16 in	3/10/2026	10799	8302	General Fund 8603
Ken's Westside Service & Towing LLC	\$	450.00	Vehicle / Eq Repair	Winching	3/4/2026	10786	8605	General Fund 8603
Ken's Westside Service & Towing LLC	\$	375.00	Vehicle / Eq Repair	Truck unit #9	3/26/2026	10820	8605	General Fund 8603
Kleindorfer Hardware	\$	(39.99)	Operating Supplies	Mailbox	3/10/2026	10800	8301	General Fund 8603
Kleindorfer Hardware	\$	26.97	Computer Support	123 Battery	3/10/2026	10800	8354	General Fund 8603
Kleindorfer Hardware	\$	34.14	Operating Supplies	Hose Nozzle	3/10/2026	10800	8301	General Fund 8603
Kleindorfer Hardware	\$	34.64	Operating Supplies	Rope, Spray Hose Nozzle	3/10/2026	10800	8301	General Fund 8603
Kleindorfer Hardware	\$	68.90	Operating Supplies	Mail box, other	3/10/2026	10800	8301	General Fund 8603
Kleindorfer Hardware	\$	62.36	Operating Supplies	Bolts, Locknuts	3/10/2026	10800	8301	General Fund 8603
Linde Gas & Equipment Inc	\$	251.48	EMS Supplies	Oxygen EMS Supplies	3/31/2026	10833	8304	General Fund 8603
Lowe's	\$	246.05	Operating Supplies	Operating Supplies	3/10/2026	EFT	8301	General Fund 8603
Med Bill	\$	783.27	Contractual	Ambulance Billing	3/4/2026	10787	8401	General Fund 8603
Medley Septic Service LLC	\$	660.00	Building Services	Septic Pump (January 6 & 20) (February 4 & 19)	3/17/2026	10812	8600	General Fund 8603
Menard's Card	\$	1,110.83	Operating Supplies	Operating Supplies	3/31/2026	EFT	8301	General Fund 8603
Menard's Card	\$	191.97	Vehicle/Eq Mnt	Vehicle/Equit Mnt	3/31/2026	EFT	8302	General Fund 8603
Midwest Natural Gas	\$	269.52	Utilities	Sta 19	3/10/2026	10801	8550	General Fund 8603
Midwest Natural Gas	\$	425.03	Utilities	Sta 39	3/10/2026	10801	8550	General Fund 8603
Monroe County Tire & Supply	\$	60.00	Vehicle / Eq Repair	Medium Truck Tire Repair	3/17/2026	10813	8605	General Fund 8603
Monroe County Tire & Supply	\$	453.75	Vehicle / Eq Repair	Tanker Tire Replacement	3/17/2026	10813	8605	General Fund 8603
Monroe County Tire & Supply	\$	645.05	Vehicle / Eq Repair	E19 Tire Replacement	3/17/2026	10813	8605	General Fund 8603
Monroe Hospital E-Cards	\$	160.00	Training	BLS completion card	3/10/2026	10802	8351	General Fund 8603
Monroe Hospital E-Cards	\$	112.50	Training	BLS Community Cards	3/26/2026	10822	8351	General Fund 8603
Mtech Incorporated	\$	65.00	Vehicle/Eq Mnt	Flange Mount Breather Vent	3/26/2026	10823	8302	General Fund 8603
Napa Auto Parts	\$	44.99	Vehicle/Eq Mnt	Heater Valve	3/4/2026	10788	8302	General Fund 8603
O'Reilly Automotive, Inc	\$	(232.60)	Vehicle/Eq Mnt	Core Credit	3/10/2026	10803	8302	General Fund 8603
O'Reilly Automotive, Inc	\$	(128.94)	Vehicle/Eq Mnt	Brackted Cal, Hose	3/10/2026	10803	8302	General Fund 8603
O'Reilly Automotive, Inc	\$	26.72	Vehicle/Eq Mnt	PS Fluid	3/10/2026	10803	8302	General Fund 8603
O'Reilly Automotive, Inc	\$	44.94	Vehicle/Eq Mnt	Oil	3/10/2026	10803	8302	General Fund 8603
O'Reilly Automotive, Inc	\$	47.89	Vehicle/Eq Mnt	Oil	3/10/2026	10803	8302	General Fund 8603
O'Reilly Automotive, Inc	\$	128.94	Vehicle/Eq Mnt	Brackted Cal, Hose	3/10/2026	10803	8302	General Fund 8603
O'Reilly Automotive, Inc	\$	136.67	Vehicle/Eq Mnt	Brake Hose, Brackted Cal	3/10/2026	10803	8302	General Fund 8603
O'Reilly Automotive, Inc	\$	126.14	Vehicle/Eq Mnt	Spark Plug, wire set, disc set	3/10/2026	10803	8302	General Fund 8603
O'Reilly Automotive, Inc	\$	47.97	Vehicle/Eq Mnt	Blue Def	3/10/2026	10803	8302	General Fund 8603

O'Reilly Automotive, Inc	\$ 50.60	Vehicle/Eq Mnt	Brake Pads	3/10/2026	10803	8302	General Fund 8603
O'Reilly Automotive, Inc	\$ 173.69	Vehicle/Eq Mnt	Hub assembly, crankshaft sen	3/10/2026	10804	8302	General Fund 8603
Peoples State Bank	\$ 34,322.73	HSA	HSA deposit	3/4/2026	EFT		General Fund 8603
PSB-Elan Financial Services	\$ 1,800.00	Medical Services	Medical Services	3/10/2026	EFT	8253	General Fund 8603
PSB-Elan Financial Services	\$ 347.02	Operating Supplies	Operating	3/10/2026	EFT	8301	General Fund 8603
PSB-Elan Financial Services	\$ 1,050.89	Vehicle/Eq Mnt	Vehicle Mnt	3/10/2026	EFT	8302	General Fund 8603
PSB-Elan Financial Services	\$ 136.09	Computer Support	Comp Support	3/10/2026	EFT	8354	General Fund 8603
PSB-Elan Financial Services	\$ 1,352.34	Telephone / Data	Telephone Data	3/10/2026	EFT	8400	General Fund 8603
PSB-Elan Financial Services	\$ 1,711.89	Contractual	Contractual	3/10/2026	EFT	8401	General Fund 8603
PSB-Elan Financial Services	\$ 142.55	Postage	Postage	3/10/2026	EFT	8402	General Fund 8603
PSB-Elan Financial Services	\$ 20.00	Travel	Travel	3/10/2026	EFT	8403	General Fund 8603
PSB-Elan Financial Services	\$ 248.97	Utilities	Utilities	3/10/2026	EFT	8550	General Fund 8603
PSB-Elan Financial Services	\$ 5,060.72	Training	Training	3/10/2026	EFT	8351	General Fund 8603
Reliance Standard Life Ins Co	\$ 1,730.00	Health Insurance-Group	Critical Illness	3/10/2026	EFT	8243	General Fund 8603
Reliance Standard Life Ins Co	\$ 1,730.00	Health Insurance-Group	Critical Illness	3/31/2026	EFT	8243	General Fund 8603
REMC	\$ 111.70	Utilities	Station 19	3/10/2026	EFT	8550	General Fund 8603
REMC	\$ 370.15	Utilities	Station 23	3/10/2026	EFT	8550	General Fund 8603
REMC	\$ 461.27	Utilities	Station 39	3/10/2026	EFT	8550	General Fund 8603
REMC	\$ 647.30	Utilities	Station 29	3/10/2026	EFT	8550	General Fund 8603
REMC	\$ 192.30	Utilities	ABW	3/10/2026	EFT	8550	General Fund 8603
Richard's Small Engine Inc.	\$ 118.91	Vehicle/Eq Mnt	Oil Filter, Air filter, etc.	3/4/2026	10789	8302	General Fund 8603
Richard's Small Engine Inc.	\$ 40.78	Vehicle/Eq Mnt	Element Assy Air Filter, Oil Filter, Oil KAW	3/17/2026	10814	8302	General Fund 8603
Richard's Small Engine Inc.	\$ 97.69	Vehicle/Eq Mnt	Element Assy Air Filter (2), Oil Filter, Oil (2) KAW	3/17/2026	10814	8302	General Fund 8603
Richard's Small Engine Inc.	\$ 231.86	Vehicle/Eq Mnt	KAW Electric Starter Kit	3/17/2026	10814	8302	General Fund 8603
Richard's Small Engine Inc.	\$ 50.62	Vehicle/Eq Mnt	Element Assy Air Filter, Oil Filter, Oil(2) KAW	3/17/2026	10814	8302	General Fund 8603
Richard's Small Engine Inc.	\$ 23.26	Vehicle/Eq Mnt	Mower 26	3/26/2026	10824	8302	General Fund 8603
Richard's Small Engine Inc.	\$ 23.26	Vehicle/Eq Mnt	Mower 39	3/26/2026	10824	8302	General Fund 8603
Richard's Small Engine Inc.	\$ 33.59	Vehicle/Eq Mnt	Mower 21 & 22	3/26/2026	10824	8302	General Fund 8603
Richard's Small Engine Inc.	\$ 194.36	Vehicle / Eq Repair	Carb Overhaul	3/26/2026	10824	8605	General Fund 8603
Richard's Small Engine Inc.	\$ 205.76	Vehicle / Eq Repair	Kawasaki Fastrak Oil	3/26/2026	10824	8605	General Fund 8603
Root & Associates LLC	\$ 5,585.00	Accounting Services	Bookkeeping March	3/26/2026	10825	8355	General Fund 8603
Root & Associates LLC	\$ 1,050.00	Accounting Services	ACA Reporting for 2025 - 1095 Cs	3/31/2026	10834	8355	General Fund 8603
Root & Associates LLC	\$ 3,500.00	Accounting Services	State Board of Accounts Report AFR	3/31/2026	10834	8355	General Fund 8603
Sam's Club	\$ 2,858.46	Operating Supplies	Operating Supplies	3/4/2026	EFT	8301	General Fund 8603
Sam's Club	\$ 870.43	Operating Supplies	Operating Supplies	3/31/2026	EFT	8301	General Fund 8603
Sam's Club	\$ 177.05	Training	Training	3/31/2026	EFT	8351	General Fund 8603
Smithville Communications	\$ 106.95	Telephone / Data	Internet St26	3/4/2026	EFT	8400	General Fund 8603
Smithville Communications	\$ 106.95	Telephone / Data	Station 26	4/20/2026	EFT	8400	General Fund 8603
South Central Indiana REMC	\$ 126.18	Utilities	Station 24G	3/4/2026	ATS	8550	General Fund 8603
South Central Indiana REMC	\$ 578.49	Utilities	Station 24	3/4/2026	ATS	8550	General Fund 8603
South Central Indiana REMC	\$ 521.29	Utilities	Station 26	3/4/2026	ATS	8550	General Fund 8603
South Central Regional Sewer Dist	\$ 42.75	Utilities	Sewer St21 - ATS Mar20	3/4/2026	ATS	8550	General Fund 8603
Southern Monroe Water Corp	\$ 85.86	Utilities	Water St21 - ATS Mar17	3/4/2026	ATS	8550	General Fund 8603
Southern Monroe Water Corp	\$ 334.55	Utilities	Water St21 - ATS Mar17	3/4/2026	ATS	8550	General Fund 8603
Standard Insurance Co.	\$ 7,233.88	Health Insurance	group dental insurance	3/10/2026	EFT	8243	General Fund 8603
Standard Insurance Co.	\$ 12,793.15	Life Insurance	Group Life ADD STD LTD	3/10/2026	EFT	8245	General Fund 8603
Standard Insurance Co.	\$ 12,341.83	Life Insurance	Group Life ADD STD LTD	4/1/2026	EFT	8245	General Fund 8603
Sternberg	\$ 267.50	Vehicle / Eq Repair	3 Axle Alignment 2015 Spartan	3/17/2026	10815	8605	General Fund 8603

Sternberg	\$ 1,232.64	Vehicle / Eq Repair	Repair Datalink Circuit	3/31/2026	10835	8605	General Fund 8603
Taylor's Tins	\$ 1,329.00	Operating Supplies	Retro Tin, Passport Insert, P Tag	3/10/2026	10805	8301	General Fund 8603
Taylor's Tins	\$ 815.00	Operating Supplies	Retro Tin w Clip(5) Passport Insert (12) P Tag w Back Design (20)	3/17/2026	10816	8301	General Fund 8603
Taylor's Tins	\$ 844.00	Operating Supplies	12 each Retro with Clip, Passport Insert, 2 Ptag Black Recruit School	3/31/2026	10836	8301	General Fund 8603
TFX Equipment Service	\$ 1,183.55	Vehicle / Eq Repair	Rescue Tank Hyd Mount	3/4/2026	10790	8605	General Fund 8603
USA Today	\$ 22.26	Legal Advertising	Bd Mtg 2-11	3/10/2026	10806	8450	General Fund 8603
Van Buren Water Inc	\$ 21.13	Utilities	Water St19 ATS Mar10	3/4/2026	ATS	8550	General Fund 8603
Van Buren Water Inc	\$ 21.13	Utilities	Water St23 ATS Mar10	3/4/2026	ATS	8550	General Fund 8603
Van Buren Water Inc	\$ 71.46	Utilities	Water St39 ATS Mar10	3/4/2026	ATS	8550	General Fund 8603
Vanhorn Tint & Accessories	\$ 110.00	Vehicle/Eq Mnt	220 decals C2-0 - C2 10 20 each	3/31/2026	10837	8302	General Fund 8603
Washington Township Water	\$ 22.00	Utilities	Water St25G	3/4/2026	10780	8550	General Fund 8603
Washington Township Water	\$ 81.78	Utilities	Water St26	3/4/2026	10780	8550	General Fund 8603
Washington Township Water	\$ 111.87	Utilities	Water St25G	3/4/2026	10780	8550	General Fund 8603
Wex Bank	\$ 9,605.20	Fuel	Fuel February	3/10/2026	EFT	8308	General Fund 8603
Wex Bank	\$ 531.55	Vehicle/Eq Mnt	Maintenance	3/10/2026	EFT	8302	General Fund 8603
Total General Fund Spent	\$ 326,250.66						
Total March Claims	\$ 333,809.33						

Monroe Fire Protection District

Statement of Financial Position

As of March 31, 2026

	TOTAL	
	AS OF MAR 31, 2026	AS OF MAR 31, 2025 (PY)
ASSETS		
Current Assets		
Bank Accounts		
1023 Savings - PSB (Rainy Day)	3,314,801.00	3,244,557.72
1024 Savings - Peoples - CUM Fund	1,599,376.10	1,836,843.33
1026 Checking - Peoples	5,258,420.28	5,104,242.92
1029 PSB - Restricted Donation Fund	1,545.06	78,686.70
1030 EMS Collections Account - PSB	8,921.73	14,525.96
Other Bank Accounts		
Inactive account	0.00	0.00
Inactive account 2	0.00	0.00
Total Other Bank Accounts	0.00	0.00
Total Bank Accounts	\$10,183,064.17	\$10,278,856.63
Other Current Assets		
Other Current Assets		
1201 Employee Receivable	0.00	0.00
1202 Refund Receivable	0.00	0.00
Total Other Current Assets	0.00	0.00
Total Other Current Assets	\$0.00	\$0.00
Total Current Assets	\$10,183,064.17	\$10,278,856.63
Fixed Assets		
2100 Land	528,300.00	528,300.00
2200 Building	8,418,865.58	7,376,814.58
2240 Construction in Progress	0.00	483,763.65
2260 Improvements Other Than Bldgs	118,219.00	118,219.00
2270 Machinery & Equipment	528,219.72	2,307,399.60
2300 Vehicles - Apparatus	12,161,369.26	11,920,192.26
2900 Accumulated Depreciation	-11,252,700.14	-12,437,393.59
Total Fixed Assets	\$10,502,273.42	\$10,297,295.50
TOTAL ASSETS	\$20,685,337.59	\$20,576,152.13

Monroe Fire Protection District

Statement of Financial Position

As of March 31, 2026

	TOTAL	
	AS OF MAR 31, 2026	AS OF MAR 31, 2025 (PY)
LIABILITIES AND EQUITY		
Liabilities		
Current Liabilities		
Credit Cards		
Visa	0.00	0.00
Total Credit Cards	\$0.00	\$0.00
Other Current Liabilities		
3050 Fica & Federal Withheld	64,840.76	56,801.98
3070 State & County Withheld	0.00	39,961.15
3090 Pension Payable	0.00	2,871.30
3091 Reimbursements Payable	0.00	0.00
3093 HSA Payable	0.00	0.00
3095 Garnishment Payable	0.00	0.00
3097 Cincinnati Life Ins Payable	-91.97	0.00
3098 AFLAC Ins Payable	-103.81	0.00
3100 Retiree Health Insurance Fund - EE	76,200.00	14,850.00
3101 Post Employee Health Insurance Liability - ER	120,000.00	
Total Other Current Liabilities	\$260,844.98	\$114,484.43
Total Current Liabilities	\$260,844.98	\$114,484.43
Long-Term Liabilities		
4000 NP - Peoples State Bank - 4423	117,027.34	265,838.39
4020 NP - Old National Bank	293,699.60	587,399.20
4050 NP - PSB - E22 - 8106	126,637.56	372,159.48
Total Long-Term Liabilities	\$537,364.50	\$1,225,397.07
Total Liabilities	\$798,209.48	\$1,339,881.50
Equity		
3900 Retained Earnings	3,838,655.33	4,056,806.63
5010 Fund Balance	19,296,279.84	18,403,269.35
Net Revenue	-3,247,807.06	-3,223,805.35
Total Equity	\$19,887,128.11	\$19,236,270.63
TOTAL LIABILITIES AND EQUITY	\$20,685,337.59	\$20,576,152.13

Monroe Fire Protection District

Statement of Activity

March 2026

	TOTAL	
	MAR 2026	JAN - MAR, 2026 (YTD)
Revenue		
6000 Other Income	425.03	4,373.21
6160 Local Income Tax (LIT) Cert Shs	380,971.66	1,142,914.98
6300 Donations	1,237.00	1,833.00
6400 EMS Revenue	8,560.73	36,083.64
9010 Interest Income	18,802.40	57,633.00
Total Revenue	\$409,996.82	\$1,242,837.83
GROSS PROFIT	\$409,996.82	\$1,242,837.83
Expenditures		
1 PERSONAL SERVICES		
1a Salaries and Wages		
8212 Salaries & Wages - Fire Chief	8,033.34	23,908.39
8213 Salaries & Wages - Deputy Chief	30,121.68	89,647.52
8214 Salaries & Wages - Asst Chief	14,056.68	41,835.46
8215 Salaries & Wages - Batallion Ch	26,110.00	77,706.68
8216 Salaries & Wages - Fire Marshal	13,055.00	38,853.34
8217 Salaries & Wages - Fleet Mgr	6,527.50	19,427.08
8219 Salaries & Wages - FF PERF Fund	50,973.28	157,926.56
8220 Salaries & Wages - FF 1977 Fund	449,224.72	1,362,532.05
8221 Salaries & Wages - Incentive	5,608.16	17,082.81
8222 Salaries & Wages - Officer Pay	54,838.00	149,327.00
8223 Salaries & Wages - Longevity	12,818.75	37,925.00
8224 Salaries & Wages - Holiday Pay		17,925.00
8226 Salaries & Wages - Part Time	51,416.36	170,058.99
8227 Salaries & Wages - Sub/Em/Tr/OT	87,682.01	203,608.59
8228 Salaries & Wages - Admin Assts	13,419.52	39,939.14
8229 Salaries & Wages - IT Spec	7,452.08	22,178.53
8230 Salaries & Wages - Trustee Comp	7,084.00	7,084.00
8231 Salaries & Wages - Ambulance	38,931.73	110,520.07
Total 1a Salaries and Wages	877,352.81	2,587,486.21
1b Employee Benefits		
8240 Social Security (Fica)	14,783.00	43,087.42
8241 Social Security (Medicare)	12,464.84	36,595.75
8242 Unemployment Ins	427.47	427.47
8243 Health Insurance (M/D/V/CI)	169,398.47	392,506.61
8244 PERF 1977 Employer Contribution	141,312.04	426,573.00
8245 Group Life Ins/ AD&D/STD/LTD	25,134.98	37,911.23
8246 PERF Fund Employer Contribution	23,902.62	68,294.37
Total 1b Employee Benefits	387,423.42	1,005,395.85

Monroe Fire Protection District

Statement of Activity

March 2026

	TOTAL	
	MAR 2026	JAN - MAR, 2026 (YTD)
1c Other Personal Services		
8253 Medical Services	3,405.59	6,230.43
Total 1c Other Personal Services	3,405.59	6,230.43
Total 1 PERSONAL SERVICES	1,268,181.82	3,599,112.49
2 SUPPLIES		
2a Repair & Maintenance Supplies		
8302 Vehicle Maintenance Supplies	5,145.62	27,593.81
Total 2a Repair & Maintenance Supplies	5,145.62	27,593.81
2b Operating Supplies ~		
8301 Operating Supplies	11,188.34	29,936.89
8304 EMS Supplies	454.67	4,934.97
8308 Fuel	9,605.20	30,414.23
8312 Fire Prevention Supplies		1,522.65
Total 2b Operating Supplies ~	21,248.21	66,808.74
2c Office Supplies ~		
8300 Office Supplies	742.03	1,497.62
Total 2c Office Supplies ~	742.03	1,497.62
Total 2 SUPPLIES	27,135.86	95,900.17
3 OTHER SERVICES & CHARGES		
3a Professional Services		
8351 Seminars/Training	7,790.02	11,210.66
8352 Legal Counsel & Expenses	4,293.50	9,516.50
8355 Accounting Services	10,135.00	20,805.00
8401 Contractual Services	2,495.16	46,409.96
Total 3a Professional Services	24,713.68	87,942.12
3b Communication & Transportation		
8400 Telephone & Data Services	4,272.14	21,408.54
8403 Travel Expenses	20.00	46.69
Total 3b Communication & Transportation	4,292.14	21,455.23
3c Printing & Advertising		
8450 Legal Advertising	22.26	62.02
Total 3c Printing & Advertising	22.26	62.02
3d Insurance		
8500 General Liability Insurance	29,160.57	106,274.07
8501 Workmens Compensation		25,976.00
Total 3d Insurance	29,160.57	132,250.07
3e Utility Service		
8550 Utilities	12,976.97	42,176.31
Total 3e Utility Service	12,976.97	42,176.31

Monroe Fire Protection District

Statement of Activity

March 2026

	TOTAL	
	MAR 2026	JAN - MAR, 2026 (YTD)
3f Repairs & Maintenance		
8354 Computer Tech Support	1,247.98	4,452.29
8600 Building Services	8,044.41	13,908.97
8605 Equipment & Vehicle Repairs	5,608.47	25,443.16
Total 3f Repairs & Maintenance	14,900.86	43,804.42
3g Other Service & Charges		
8402 Postage	142.55	185.50
Total 3g Other Service & Charges	142.55	185.50
Total 3 OTHER SERVICES & CHARGES	86,209.03	327,875.67
Total Expenditures	\$1,381,526.71	\$4,022,888.33
NET OPERATING REVENUE	\$ -971,529.89	\$ -2,780,050.50
Other Expenditures		
CUM FUND EXPENSES		
Buildings		
8782 CUM Fund - Station 21 Mortgage		293,790.97
8784 CUM Fund - Bldg Renovations	3,330.00	29,750.56
Total Buildings	3,330.00	323,541.53
Machinery, Eqpt & Vehicles		
8779 CUM Fund - Small Vehicles	1,300.00	3,228.00
8780 CUM Fund - Misc/Eqpt/Cap Outlay	800.00	9,147.21
8781 CUM Fund - Pers Prot Eqpt (PPE)	1,627.92	5,574.82
8785 CUM Fund - Rescue 11(22)Replace		40,170.41
8788 CUM Fund - Engine 22		64,437.78
8790 CUM Fund-Apparatus Replacement		19,689.07
Total Machinery, Eqpt & Vehicles	3,727.92	142,247.29
Total CUM FUND EXPENSES	7,057.92	465,788.82
OTHER MISC EXPENSES		
8435 Clothing & Events		1,164.07
8440 Meals & Awards	500.75	803.67
Total OTHER MISC EXPENSES	500.75	1,967.74
Total Other Expenditures	\$7,558.67	\$467,756.56
NET OTHER REVENUE	\$ -7,558.67	\$ -467,756.56
NET REVENUE	\$ -979,088.56	\$ -3,247,807.06

Monroe Fire Protection District

Statement of Activity - YTD by Fund

January - March, 2026

	8603 - SPECIAL FIRE GENERAL	8691 - SPECIAL CUM FIRE	8700 - EMS FUND	8840 - DONATION FUND	8875 - RESTRICTED DONATION FUND	RAINY DAY	TOTAL
Revenue							
6000 Other Income	4,248.18		0.03	125.00			\$4,373.21
6160 Local Income Tax (LIT) Cert Shs	1,142,914.98						\$1,142,914.98
6300 Donations				1,833.00			\$1,833.00
6400 EMS Revenue			36,083.64				\$36,083.64
9010 Interest Income	33,120.43	8,218.28	0.78		0.19	16,293.32	\$57,633.00
Total Revenue	\$1,180,283.59	\$8,218.28	\$36,084.45	\$1,958.00	\$0.19	\$16,293.32	\$1,242,837.83
GROSS PROFIT	\$1,180,283.59	\$8,218.28	\$36,084.45	\$1,958.00	\$0.19	\$16,293.32	\$1,242,837.83
Expenditures							
1 PERSONAL SERVICES							
1a Salaries and Wages							
8212 Salaries & Wages - Fire Chief	23,908.39						\$23,908.39
8213 Salaries & Wages - Deputy Chief	89,647.52						\$89,647.52
8214 Salaries & Wages - Asst Chief	41,835.46						\$41,835.46
8215 Salaries & Wages - Battalion Ch	77,706.68						\$77,706.68
8216 Salaries & Wages - Fire Marshal	38,853.34						\$38,853.34
8217 Salaries & Wages - Fleet Mgr	19,427.08						\$19,427.08
8219 Salaries & Wages - FF PERF Fund	157,926.56						\$157,926.56
8220 Salaries & Wages - FF 1977 Fund	1,362,532.05						\$1,362,532.05
8221 Salaries & Wages - Incentive	17,082.81						\$17,082.81
8222 Salaries & Wages - Officer Pay	149,327.00						\$149,327.00
8223 Salaries & Wages - Longevity	37,925.00						\$37,925.00
8224 Salaries & Wages - Holiday Pay	17,925.00						\$17,925.00
8226 Salaries & Wages - Part Time	170,058.99						\$170,058.99
8227 Salaries & Wages - Sub/Em/Tr/OT	203,608.59						\$203,608.59
8228 Salaries & Wages - Admin Assts	39,939.14						\$39,939.14
8229 Salaries & Wages - IT Spec	22,178.53						\$22,178.53
8230 Salaries & Wages - Trustee Comp	7,084.00						\$7,084.00
8231 Salaries & Wages - Ambulance	110,520.07						\$110,520.07
Total 1a Salaries and Wages	2,587,486.21						\$2,587,486.21
1b Employee Benefits							
8240 Social Security (Fica)	43,087.42						\$43,087.42
8241 Social Security (Medicare)	36,595.75						\$36,595.75
8242 Unemployment Ins	427.47						\$427.47
8243 Health Insurance (M/D/V/CI)	392,506.61						\$392,506.61
8244 PERF 1977 Employer Contribution	426,573.00						\$426,573.00
8245 Group Life Ins/ AD&D/STD/LTD	37,911.23						\$37,911.23
8246 PERF Fund Employer Contribution	68,294.37						\$68,294.37
Total 1b Employee Benefits	1,005,395.85						\$1,005,395.85
1c Other Personal Services							
8253 Medical Services	6,230.43						\$6,230.43
Total 1c Other Personal Services	6,230.43						\$6,230.43
Total 1 PERSONAL SERVICES	3,599,112.49						\$3,599,112.49
2 SUPPLIES							
2a Repair & Maintenance Supplies							
8302 Vehicle Maintenance Supplies	27,593.81						\$27,593.81
Total 2a Repair & Maintenance Supplies	27,593.81						\$27,593.81
2b Operating Supplies ~							
8301 Operating Supplies	29,936.89						\$29,936.89
8304 EMS Supplies	4,934.97						\$4,934.97
8308 Fuel	30,414.23						\$30,414.23
8312 Fire Prevention Supplies	1,522.65						\$1,522.65
Total 2b Operating Supplies ~	66,808.74						\$66,808.74
2c Office Supplies ~							
8300 Office Supplies	1,497.62						\$1,497.62
Total 2c Office Supplies ~	1,497.62						\$1,497.62
Total 2 SUPPLIES	95,900.17						\$95,900.17
3 OTHER SERVICES & CHARGES							
3a Professional Services							
8351 Seminars/Training	11,210.66						\$11,210.66
8352 Legal Counsel & Expenses	9,516.50						\$9,516.50
8355 Accounting Services	20,805.00						\$20,805.00
8401 Contractual Services	46,409.96						\$46,409.96
Total 3a Professional Services	87,942.12						\$87,942.12
3b Communication & Transportation							
8400 Telephone & Data Services	21,408.54						\$21,408.54
8403 Travel Expenses	46.69						\$46.69
Total 3b Communication & Transportation	21,455.23						\$21,455.23
3c Printing & Advertising							
8450 Legal Advertising	62.02						\$62.02
Total 3c Printing & Advertising	62.02						\$62.02

Monroe Fire Protection District

Statement of Activity - YTD by Fund

January - March, 2026

	8603 - SPECIAL FIRE GENERAL	8691 - SPECIAL CUM FIRE	8700 - EMS FUND	8840 - DONATION FUND	8875 - RESTRICTED DONATION FUND	RAINY DAY	TOTAL
3d Insurance							\$0.00
8500 General Liability Insurance	106,274.07						\$106,274.07
8501 Workmens Compensation	25,976.00						\$25,976.00
Total 3d Insurance	132,250.07						\$132,250.07
3e Utility Service							\$0.00
8550 Utilities	42,176.31						\$42,176.31
Total 3e Utility Service	42,176.31						\$42,176.31
3f Repairs & Maintenance							\$0.00
8354 Computer Tech Support	4,452.29						\$4,452.29
8600 Building Services	13,908.97						\$13,908.97
8605 Equipment & Vehicle Repairs	25,443.16						\$25,443.16
Total 3f Repairs & Maintenance	43,804.42						\$43,804.42
3g Other Service & Charges							\$0.00
8402 Postage	185.50						\$185.50
Total 3g Other Service & Charges	185.50						\$185.50
Total 3 OTHER SERVICES & CHARGES	327,875.67						\$327,875.67
Total Expenditures	\$4,022,888.33	\$0.00	\$0.00	\$0.00		\$0.00	\$4,022,888.33
NET OPERATING REVENUE	\$ -2,842,604.74	\$8,218.28	\$36,084.45	\$1,958.00		\$0.19	\$16,293.32
Other Expenditures							\$0.00
CUM FUND EXPENSES							\$0.00
Buildings							\$0.00
8782 CUM Fund - Station 21 Mortgage		293,790.97					\$293,790.97
8784 CUM Fund - Bldg Renovations		29,750.56					\$29,750.56
Total Buildings		323,541.53					\$323,541.53
Machinery, Eqpt & Vehicles							\$0.00
8779 CUM Fund - Small Vehicles		3,228.00					\$3,228.00
8780 CUM Fund - Misc/Eqpt/Cap Outlay		9,147.21					\$9,147.21
8781 CUM Fund - Pers Prot Eqpt (PPE)		5,574.82					\$5,574.82
8785 CUM Fund - Rescue 11 (22) Replace		40,170.41					\$40,170.41
8788 CUM Fund - Engine 22		64,437.78					\$64,437.78
8790 CUM Fund-Apparatus Replacement		19,689.07					\$19,689.07
Total Machinery, Eqpt & Vehicles		142,247.29					\$142,247.29
Total CUM FUND EXPENSES		465,788.82					\$465,788.82
OTHER MISC EXPENSES							\$0.00
8435 Clothing & Events				1,164.07			\$1,164.07
8440 Meals & Awards				803.67			\$803.67
Total OTHER MISC EXPENSES				1,967.74			\$1,967.74
Total Other Expenditures	\$0.00	\$465,788.82	\$0.00	\$1,967.74		\$0.00	\$467,756.56
NET OTHER REVENUE	\$0.00	\$ -465,788.82	\$0.00	\$ -1,967.74		\$0.00	\$ -467,756.56
NET REVENUE	\$ -2,842,604.74	\$ -457,570.54	\$36,084.45	\$ -9.74		\$0.19	\$16,293.32
							\$ -3,247,807.06

Monroe Fire Protection District

Budget vs. Actuals: Budget_FY26_P&L_1 - FY26 P&L

January - December 2026

	TOTAL			
	ACTUAL	BUDGET	OVER BUDGET	% OF BUDGET
Revenue				
6000 Other Income	4,373.21		4,373.21	
6110 Vehicle/Aircraft Excise Tax		521,333.00	-521,333.00	
6111 CUM Vehicle/Aircraft Excise Tax		69,442.00	-69,442.00	
6140 CVET		12,470.00	-12,470.00	
6160 Local Income Tax (LIT) Cert Shs	1,142,914.98	4,571,660.00	-3,428,745.02	25.00 %
6180 Fire Protection Contracts/Fees		270,983.00	-270,983.00	
6190 CUM Fire Protection Contr/Fees		18,000.00	-18,000.00	
6300 Donations	1,833.00		1,833.00	
6400 EMS Revenue	36,083.64	500,000.00	-463,916.36	7.22 %
9010 Interest Income	57,633.00		57,633.00	
Total Revenue	\$1,242,837.83	\$5,963,888.00	\$ -4,721,050.17	20.84 %
GROSS PROFIT	\$1,242,837.83	\$5,963,888.00	\$ -4,721,050.17	20.84 %
Expenditures				
1 PERSONAL SERVICES				
1a Salaries and Wages				
8212 Salaries & Wages - Fire Chief	23,908.39	96,400.00	-72,491.61	24.80 %
8213 Salaries & Wages - Deputy Chief	89,647.52	361,460.00	-271,812.48	24.80 %
8214 Salaries & Wages - Asst Chief	41,835.46	168,680.00	-126,844.54	24.80 %
8215 Salaries & Wages - Batallion Ch	77,706.68	391,650.00	-313,943.32	19.84 %
8216 Salaries & Wages - Fire Marshal	38,853.34	156,660.00	-117,806.66	24.80 %
8217 Salaries & Wages - Fleet Mgr	19,427.08	78,330.00	-58,902.92	24.80 %
8219 Salaries & Wages - FF PERF Fund	157,926.56	688,149.00	-530,222.44	22.95 %
8220 Salaries & Wages - FF 1977 Fund	1,362,532.05	5,963,958.00	-4,601,425.95	22.85 %
8221 Salaries & Wages - Incentive	17,082.81	218,800.00	-201,717.19	7.81 %
8222 Salaries & Wages - Officer Pay	149,327.00	702,000.00	-552,673.00	21.27 %
8223 Salaries & Wages - Longevity	37,925.00	172,050.00	-134,125.00	22.04 %
8224 Salaries & Wages - Holiday Pay	17,925.00	57,750.00	-39,825.00	31.04 %
8225 Salaries & Wages - Spec Event		0.00	0.00	
8226 Salaries & Wages - Part Time	170,058.99	698,800.00	-528,741.01	24.34 %
8227 Salaries & Wages - Sub/Em/Tr/OT	203,608.59	605,000.00	-401,391.41	33.65 %
8228 Salaries & Wages - Admin Assts	39,939.14	161,034.00	-121,094.86	24.80 %
8229 Salaries & Wages - IT Spec	22,178.53	89,425.00	-67,246.47	24.80 %
8230 Salaries & Wages - Trustee Comp	7,084.00	28,341.00	-21,257.00	25.00 %
8231 Salaries & Wages - Ambulance	110,520.07	0.00	110,520.07	
8235 Salaries & Wages - Uniform All		169,000.00	-169,000.00	
8254 Salaries & Wages - Early Retire		25,000.00	-25,000.00	
Total 1a Salaries and Wages	2,587,486.21	10,832,487.00	-8,245,000.79	23.89 %
1b Employee Benefits				
8240 Social Security (Fica)	43,087.42	194,170.00	-151,082.58	22.19 %
8241 Social Security (Medicare)	36,595.75	156,708.00	-120,112.25	23.35 %
8242 Unemployment Ins	427.47	20,000.00	-19,572.53	2.14 %
8243 Health Insurance (M/D/V/CI)	392,506.61	2,153,763.00	-1,761,256.39	18.22 %

Monroe Fire Protection District

Budget vs. Actuals: Budget_FY26_P&L_1 - FY26 P&L

January - December 2026

	TOTAL			
	ACTUAL	BUDGET	OVER BUDGET	% OF BUDGET
8244 PERF 1977 Employer Contribution	426,573.00	1,877,500.00	-1,450,927.00	22.72 %
8245 Group Life Ins/ AD&D/STD/LTD	37,911.23	167,600.00	-129,688.77	22.62 %
8246 PERF Fund Employer Contribution	68,294.37	386,757.00	-318,462.63	17.66 %
8255 Post-Employment Health Ins		60,000.00	-60,000.00	
Total 1b Employee Benefits	1,005,395.85	5,016,498.00	-4,011,102.15	20.04 %
1c Other Personal Services				
8251 Volunteer Fire Co Contract		12,500.00	-12,500.00	
8253 Medical Services	6,230.43	127,406.90	-121,176.47	4.89 %
Total 1c Other Personal Services	6,230.43	139,906.90	-133,676.47	4.45 %
Total 1 PERSONAL SERVICES	3,599,112.49	15,988,891.90	-12,389,779.41	22.51 %
2 SUPPLIES				
2a Repair & Maintenance Supplies				
8302 Vehicle Maintenance Supplies	27,593.81	121,199.42	-93,605.61	22.77 %
Total 2a Repair & Maintenance Supplies	27,593.81	121,199.42	-93,605.61	22.77 %
2b Operating Supplies ~				
8301 Operating Supplies	29,936.89	134,113.47	-104,176.58	22.32 %
8304 EMS Supplies	4,934.97	40,000.00	-35,065.03	12.34 %
8306 IVFA Dues		3,500.00	-3,500.00	
8308 Fuel	30,414.23	160,000.00	-129,585.77	19.01 %
8311 Special Chemical Supplies		5,000.00	-5,000.00	
8312 Fire Prevention Supplies	1,522.65	12,975.65	-11,453.00	11.73 %
8314 Haz Mat Mitigation Supplies		10,000.00	-10,000.00	
Total 2b Operating Supplies ~	66,808.74	365,589.12	-298,780.38	18.27 %
2c Office Supplies ~				
8300 Office Supplies	1,497.62	20,000.00	-18,502.38	7.49 %
8303 Promotional Supplies		17,500.00	-17,500.00	
8313 Inspection/Investigation Supply		1,250.00	-1,250.00	
Total 2c Office Supplies ~	1,497.62	38,750.00	-37,252.38	3.86 %
2d Other Supplies				
8315 Color Guard Supplies		2,000.00	-2,000.00	
Total 2d Other Supplies		2,000.00	-2,000.00	
Total 2 SUPPLIES	95,900.17	527,538.54	-431,638.37	18.18 %
3 OTHER SERVICES & CHARGES				
3a Professional Services				
8351 Seminars/Training	11,210.66	60,000.00	-48,789.34	18.68 %
8352 Legal Counsel & Expenses	9,516.50	51,177.12	-41,660.62	18.60 %
8353 Equipment Tests/Certifications		80,000.00	-80,000.00	
8355 Accounting Services	20,805.00	69,920.00	-49,115.00	29.76 %
8401 Contractual Services	46,409.96	97,055.00	-50,645.04	47.82 %
Total 3a Professional Services	87,942.12	358,152.12	-270,210.00	24.55 %
3b Communication & Transportation				
8400 Telephone & Data Services	21,408.54	81,000.00	-59,591.46	26.43 %

Monroe Fire Protection District

Budget vs. Actuals: Budget_FY26_P&L_1 - FY26 P&L

January - December 2026

	TOTAL			
	ACTUAL	BUDGET	OVER BUDGET	% OF BUDGET
8403 Travel Expenses	46.69	15,000.00	-14,953.31	0.31 %
Total 3b Communication & Transportation	21,455.23	96,000.00	-74,544.77	22.35 %
3c Printing & Advertising				
8450 Legal Advertising	62.02	1,000.00	-937.98	6.20 %
8451 Printing		1,000.00	-1,000.00	
Total 3c Printing & Advertising	62.02	2,000.00	-1,937.98	3.10 %
3d Insurance				
8500 General Liability Insurance	106,274.07	196,000.00	-89,725.93	54.22 %
8501 Workmens Compensation	25,976.00	210,000.00	-184,024.00	12.37 %
Total 3d Insurance	132,250.07	406,000.00	-273,749.93	32.57 %
3e Utility Service				
8550 Utilities	42,176.31	162,500.00	-120,323.69	25.95 %
Total 3e Utility Service	42,176.31	162,500.00	-120,323.69	25.95 %
3f Repairs & Maintenance				
8354 Computer Tech Support	4,452.29	40,398.17	-35,945.88	11.02 %
8600 Building Services	13,908.97	50,000.00	-36,091.03	27.82 %
8605 Equipment & Vehicle Repairs	25,443.16	108,875.99	-83,432.83	23.37 %
Total 3f Repairs & Maintenance	43,804.42	199,274.16	-155,469.74	21.98 %
3g Other Service & Charges				
8402 Postage	185.50	1,500.00	-1,314.50	12.37 %
Total 3g Other Service & Charges	185.50	1,500.00	-1,314.50	12.37 %
Total 3 OTHER SERVICES & CHARGES	327,875.67	1,225,426.28	-897,550.61	26.76 %
Total Expenditures	\$4,022,888.33	\$17,741,856.72	\$ -13,718,968.39	22.67 %
NET OPERATING REVENUE	\$ -2,780,050.50	\$ -11,777,968.72	\$8,997,918.22	23.60 %
Other Expenditures				
CUM FUND EXPENSES				
Buildings				
8782 CUM Fund - Station 21 Mortgage	293,790.97	293,795.00	-4.03	100.00 %
8784 CUM Fund - Bldg Renovations	29,750.56	172,662.94	-142,912.38	17.23 %
Total Buildings	323,541.53	466,457.94	-142,916.41	69.36 %
Machinery, Eqpt & Vehicles				
8779 CUM Fund - Small Vehicles	3,228.00	160,000.00	-156,772.00	2.02 %
8780 CUM Fund - Misc/Eqpt/Cap Outlay	9,147.21	231,490.99	-222,343.78	3.95 %
8781 CUM Fund - Pers Prot Eqpt (PPE)	5,574.82	219,074.50	-213,499.68	2.54 %
8785 CUM Fund - Rescue 11(22)Replace	40,170.41	120,511.00	-80,340.59	33.33 %
8788 CUM Fund - Engine 22	64,437.78	128,876.00	-64,438.22	50.00 %
8790 CUM Fund-Apparatus Replacement	19,689.07	169,689.07	-150,000.00	11.60 %
Total Machinery, Eqpt & Vehicles	142,247.29	1,029,641.56	-887,394.27	13.82 %
Total CUM FUND EXPENSES	465,788.82	1,496,099.50	-1,030,310.68	31.13 %
OTHER MISC EXPENSES				
8435 Clothing & Events	1,164.07		1,164.07	

Monroe Fire Protection District

Budget vs. Actuals: Budget_FY26_P&L_1 - FY26 P&L

January - December 2026

	TOTAL			
	ACTUAL	BUDGET	OVER BUDGET	% OF BUDGET
8440 Meals & Awards	803.67		803.67	
8892 Rainy Day - Machinery, Eqpt, Vehicles		1,700,000.00	-1,700,000.00	
Total OTHER MISC EXPENSES	1,967.74	1,700,000.00	-1,698,032.26	0.12 %
Total Other Expenditures	\$467,756.56	\$3,196,099.50	\$ -2,728,342.94	14.64 %
NET OTHER REVENUE	\$ -467,756.56	\$ -3,196,099.50	\$2,728,342.94	14.64 %
NET REVENUE	\$ -3,247,807.06	\$ -14,974,068.22	\$11,726,261.16	21.69 %