

AUTOMATION STUDIO™ Educational Edition

The Tool of Choice for Teaching,
Training and Learning Automotive
Engineering Technologies



*Your Automotive
Teaching and Training Platform*



Complete Software Solution for Teaching Future Automotive Technicians and Engineers

If you teach subjects related to automotive technologies, the illustration of concepts and the behaviour of systems are no doubt at the heart of your requirements.

Used in thousands of schools worldwide, Automation Studio™ is a unique software solution, which offers intuitive design, animation, simulation and system analysis features in a versatile and user-friendly environment. Automation Studio™ allows teachers to present more content in less time, improves students' understanding of concepts and diagnosis capabilities and brings to schools, colleges and universities an optimal return on investment.

HIGH SCHOOL

VOCATIONAL TRAINING

CORPORATE TRAINING

COLLEGE

UNIVERSITY WORKFORCE

WORKFORCE

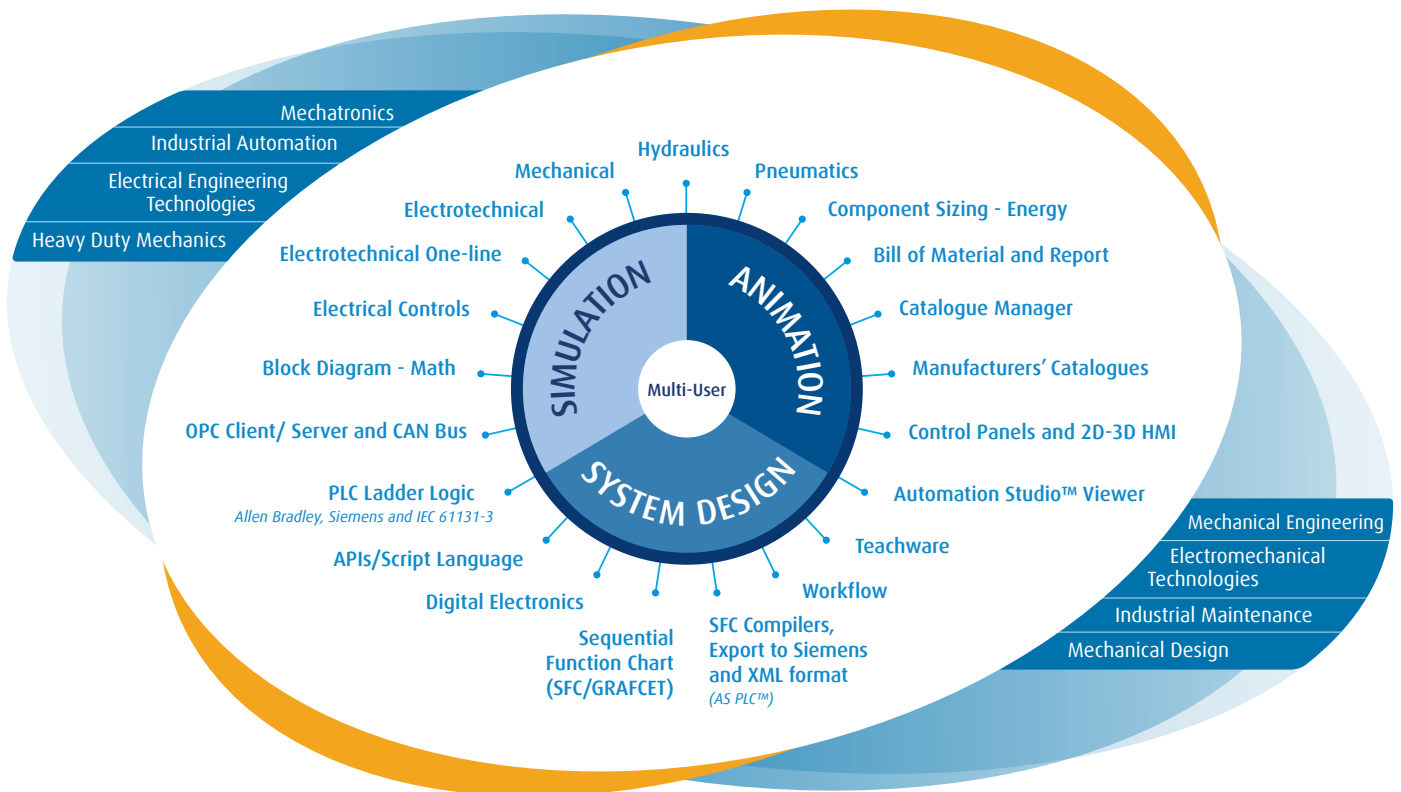



Train on all Automotive Systems in Automation Studio™

The Vehicle Library in Automation Studio™ features mechanical, electric, hydraulic and electronic components that allow students to design and study the most important systems in today's vehicles.

The screenshot displays the Automation Studio™ interface with several key components highlighted by callouts:

- Automotive Library:** Points to the Library Explorer on the left, which contains a tree view of components such as Clutches, Wheel, Measuring Instruments, and various actuators and sensors.
- Hydraulics:** Points to a hydraulic circuit diagram in the top-left pane, showing pressure levels (e.g., 70.04 bar, 69.91 bar) and flow paths.
- Electrical:** Points to an electrical circuit diagram in the top-middle pane, featuring a digital multimeter (MI-32) displaying -310.02 V and various electrical components like resistors and capacitors.
- Car Cruising Animation:** Points to a 3D rendering of a car on a road at night, with a dashboard and city skyline in the background.
- 3D Animation:** Points to a 3D model of a solenoid valve in the bottom-left pane.
- Performance Curves:** Points to a graph in the bottom-middle pane showing pressure (bar) over time, with data points like 2301 and 1195.
- Mechanical:** Points to a mechanical diagram in the bottom-right pane showing a motor (M1) and torque (Torque Tm -13.6).

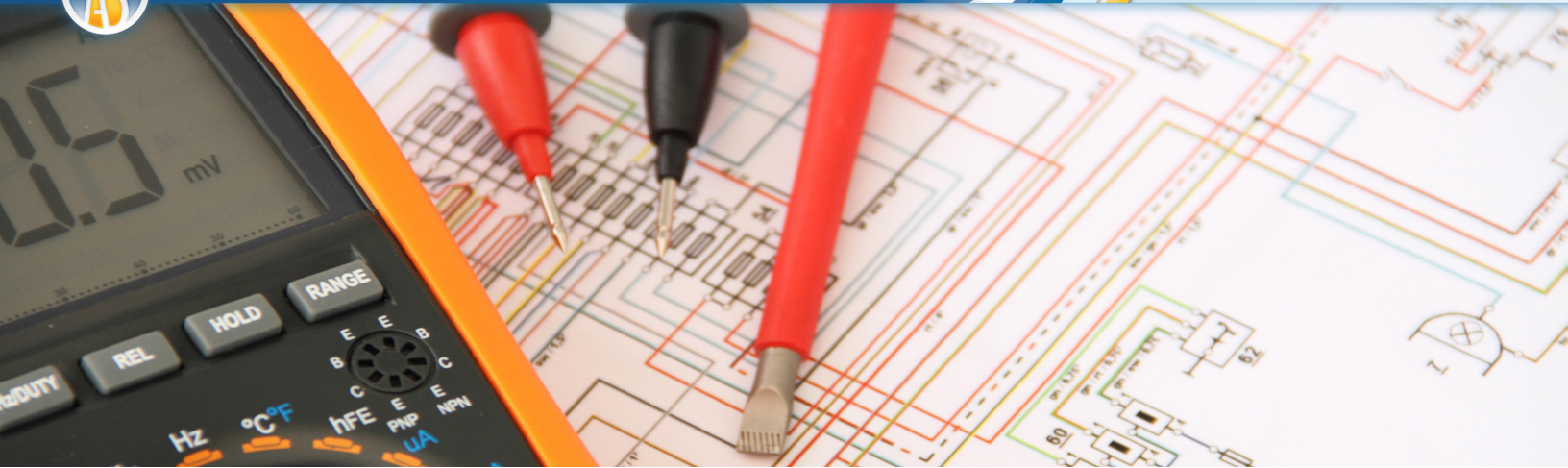

Drag-and-drop components from the Vehicle Library to quickly draw systems

Navigate through the Vehicle Library to find all components required to build your systems, including powertrain, brakes, steering, control and more. Symbols are compliant with several international standards: SAE J2221, JIC, IEC, NEMA, ISO ...

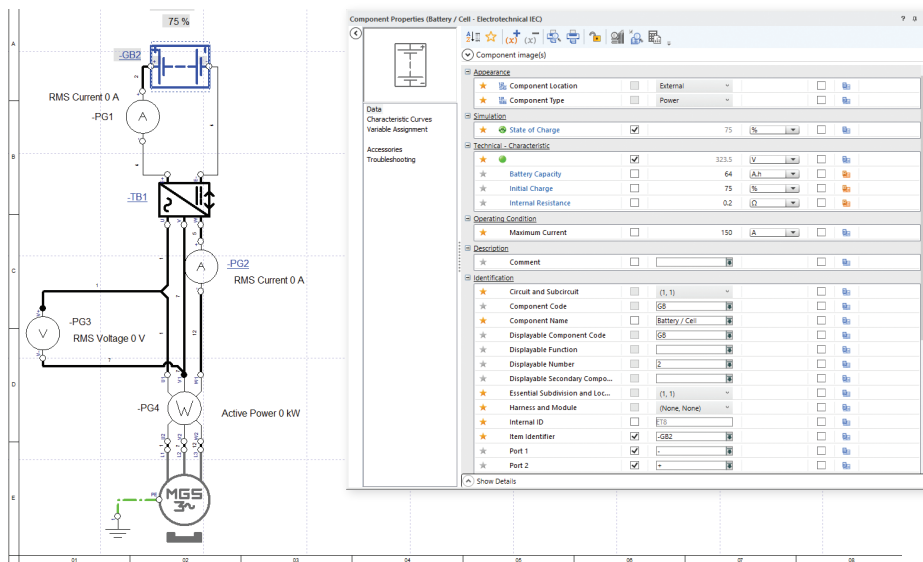
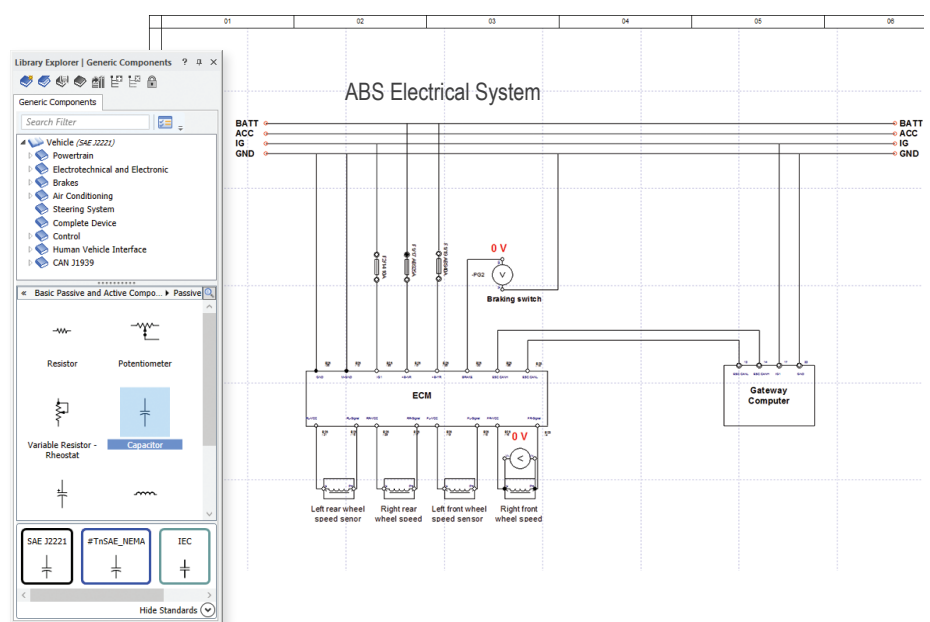

Adjust component parameters to visualize their effect during simulation

Default simulation parameters (battery capacity, initial charge, internal resistance, voltage, frequency ...) set for each component can easily be changed in order to visualize their effect during simulation.

Users can also create and configure engines, gear boxes, relays, motors, etc., to obtain a component graphically and technically compliant to real performances.



Simulate your circuits to illustrate automotive concepts

With its animation and simulation capabilities, Automation Studio™ makes it easy to study the behaviour of different automotive systems such as ABS system, EV battery, transmission, air conditioning, etc., and understand their main characteristics.

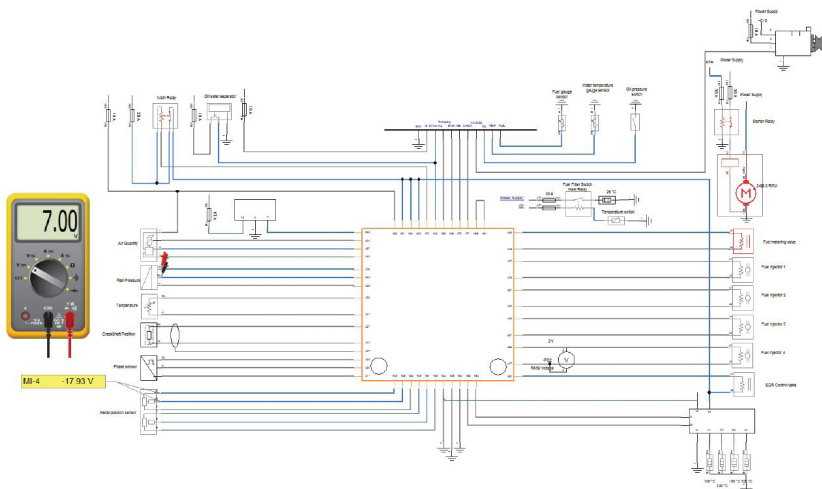
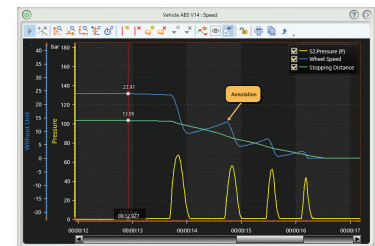
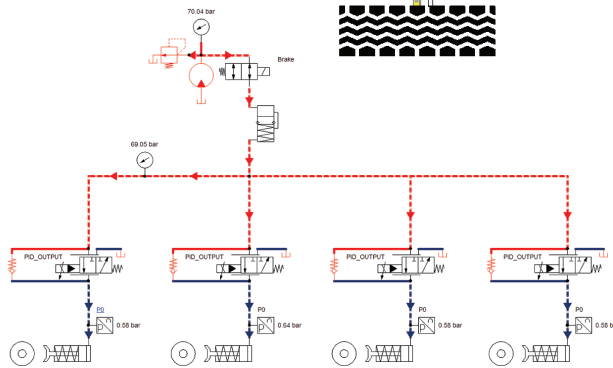
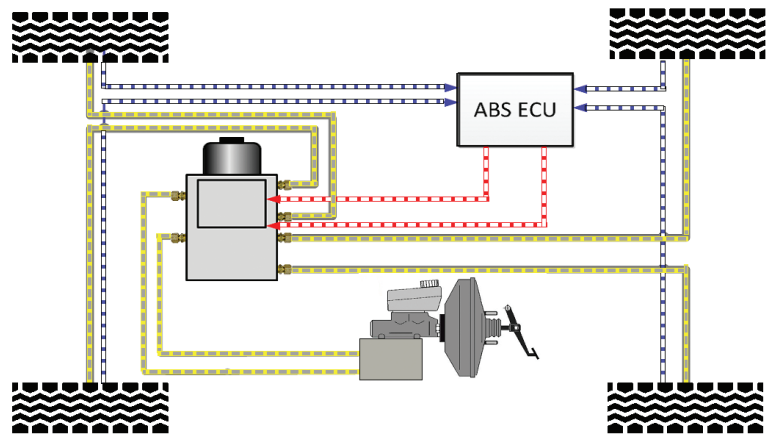

Analyze system behaviour using virtual measuring instruments

During simulation, virtual measuring instruments can be placed directly on components to measure a wide range of parameters that can be recorded and viewed in the Plotter.



Practice on virtual labs before getting hands-on

Use components from the Vehicle Library to recreate virtually the same labs that are provided with your automotive training equipment. Students will be much more efficient once they move to the hands-on labs.

Improve diagnostics and troubleshooting skills

There are no limitations on the type of real-world problems that can be simulated in Automation Studio™. Users can Create scenarios with built-in failures to safely practice diagnostic and troubleshooting procedures.

www.fengxb.com

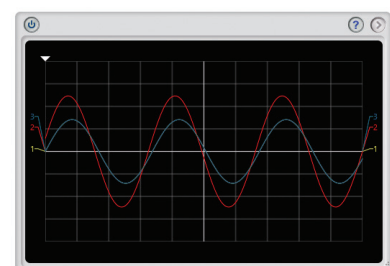
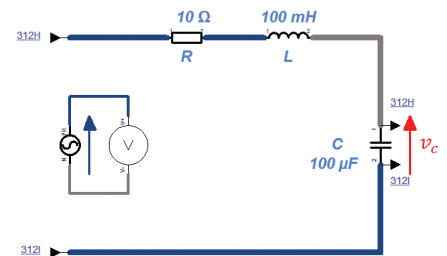
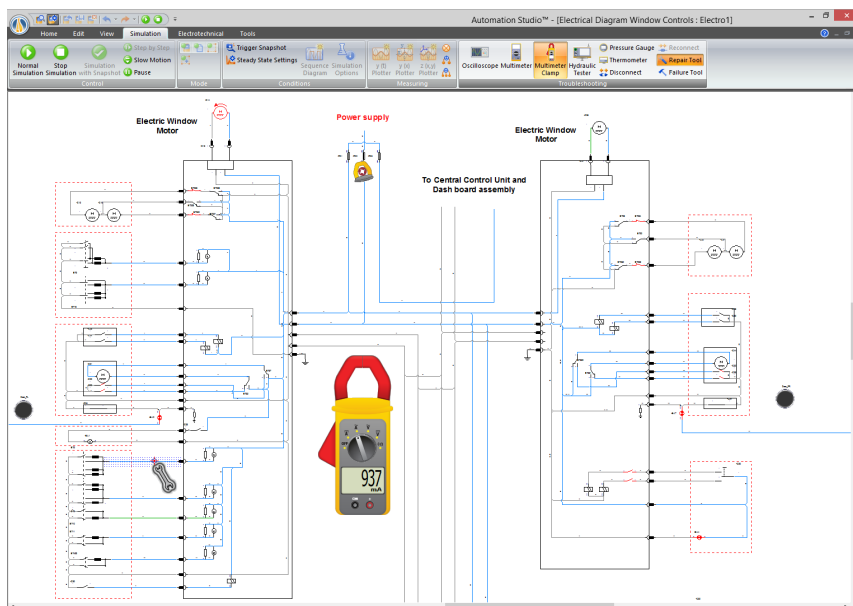



Create dashboards and 2D/3D animations to complement teaching activities

Create dashboards and 2D/3D animations linked with the circuit, enhancing your schematic and making it more visual for students. It is possible to visualize, simulate and animate them simultaneously with the technologies that drive the system.

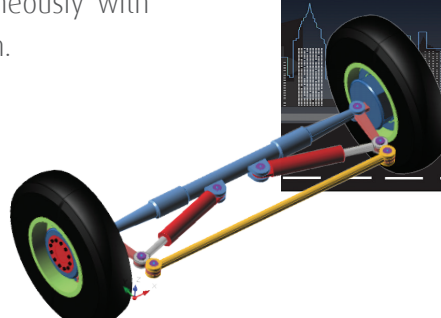

Connect to external devices

Connect external devices, via USB, CAN Bus or OPC, with the virtual vehicle system in Automation Studio™ to help student understand the interaction between software and hardware.

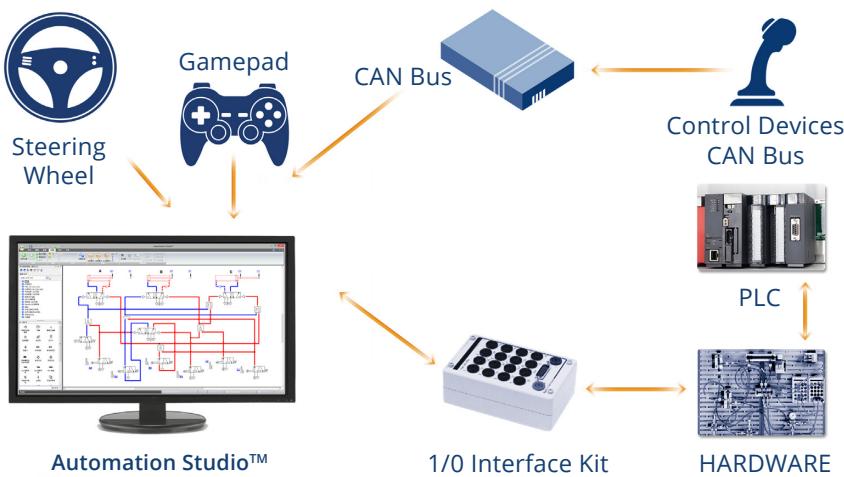

Use Automation Studio™ anywhere, anytime

Automation Studio™ gives you the flexibility to prepare and simulate your teaching exercises in class or from home with its online remote access. It also gives students the liberty to continue their learning process at their own pace.

Libraries and Modules

- Electrotechnical (AC/DC)
- Hydraulics/Proportional Hydraulics
- Pneumatics/Proportional Pneumatics
- Electrical Controls
- PLC Ladder Logic, Allen Bradley Siemens, LS Electric, IEC 61131
- Sequential Function Chart (SFC/GRAFNET)
- Digital Electronics
- Electrotechnical One-line
- 2D-3D HMI and Control Panels
- Block Diagram-Math
- Fluid Power Component Sizing
- Electrical Component Sizing
- Troubleshooting and Diagnostics
- Mechanical Links
- Catalogue Manager
- Bill of Materials and Reports
- OPC Client, OPC Server
- CAN bus
- SFC Export to Siemens and XML format (Automation Studio™ PLC)
- APIs/Script Language
- Workflow Manager

Annual Maintenance and Technical Support Plan

Subscribe to our Annual Maintenance and Technical Support Plan which grants you, for a period of one year, exclusive advantages, such as:

- Remote Access Licensing (WAN1)
- Software updates, service releases, new versions
- Online training session (2 hours)
- Unlimited technical support (phone, fax, email, technical support portal)
- Teachware for hydraulic, pneumatic, electrical and automation
- Manufacturers' Catalogues
- Access to already made 3D virtual systems

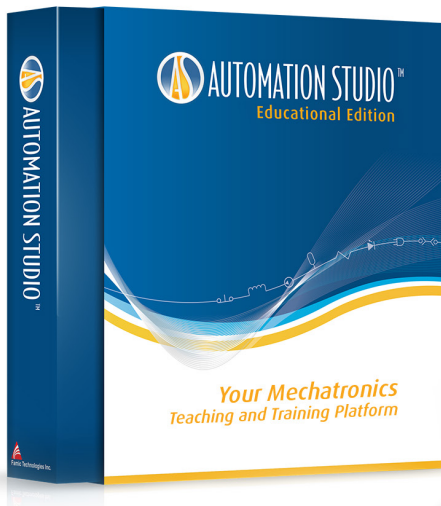

**FREE Personalized
Online Demonstration**

See Automation Studio™ in action
from wherever you are!



**For a more advanced use of Automation Studio™
Attend One of Our Training Sessions!**

While Automation Studio™ can be used without training, we offer training programs that provide in-depth knowledge for a wider range of uses. Whether online, on-site or at our offices, we have the right training for you!



A Product of  **Famic Technologies Inc.**

Canada (Headquarters)
Famic Technologies Inc.
300-8585, route Transcanadienne
Saint-Laurent QC H4S 1Z6
Canada

+1 (514) 748-8050
+1 (514) 748-8521



Germany
Famic Technologies GmbH
Julius-Hatry-Straße 1
68163 Mannheim,
Germany

+49 (0) 621 15028 579

India
Famic Technologies Pvt. Ltd.
Tower S4, Unit No. 204, Magarpatta
Hadapsar, Pune, Maharashtra 411028
India

+91 70 2822 1468

Distributed by

www.famictech.com