

IDEA

SCIENCE

INTENSITY

PRECISION FLUID & AIR BATH METROLOGY GRADE

July 2025



ANALYSION
Develop Smart

Prepared by
Mike T. Nouei

301 Harbour PI Dr,
Tampa, FL 33602

+1 437-421-9497
www.analysion.com

TEAM

ENGINEERING



Precision Temperature Controller

Next-Generation Calibration Platform

Overview:

Inspired by the proven performance of Fluke 5698, Guildline's 5600 and 5032 models, this upgraded precision temperature controller introduces advanced digital control, enhanced accuracy, and modern interfacing for calibration-grade fluid and air bath systems.

The Precision Temperature Calibrator module is designed to calibrate high-accuracy RTD sensors used in temperature control systems. This module enables automatic or manual calculation of Callendar–Van Dusen coefficients (A, B, and C) and supports calibration workflows based on internationally recognized standards.

Analysion proudly introduces two new precision temperature control instruments:

The ThermoCore F500 and the AeroStasis A300, engineered for exceptional thermal stability in fluid and air bath environments:

- **ThermoCore F500** – A high-precision **fluid bath** that achieves **± 0.0005 °C stability**
- **AeroStasis A300** – A programmable **air bath** delivering **± 0.002 °C stability**

PATENTED by USPTO

Application # 63/843,322



Key Technical Features:

1. High-Performance MCU Core

- Powered by the ESP32-S3: 32-bit dual-core microcontroller with integrated Wi-Fi and Bluetooth for modern network connectivity.
- 32-bit dual-core Xtensa® LX7 CPU @ 240 MHz
- Rich peripheral interface including SPI, I²C, UART, ADC, and DAC
- Integrated Wi-Fi and Bluetooth LE, allowing remote monitoring and wireless updates
- Secure boot and hardware encryption for data integrity
- Large internal RAM and flash support for multi-threaded control tasks and GUI handling

2. Precision Analog Front-End

- TI 32-bit ADC with ultra-stable 5.000 V reference voltage.
- Vishay custom 0.0001% precision resistors ensure minimal drift for RTD excitation biasing.
- To achieve world-class temperature measurement resolution and stability, ThermoCore F500 and AeroStasis A300 utilize the Texas Instruments ADC126x family of 32-bit delta-sigma ADCs, paired with a 5.000 V ultra-precision voltage reference.
- 32-bit resolution for sub-microkelvin measurement precision
- Ultra-low noise performance (0.2 μ V RMS typical)
- True differential inputs, ideal for ratio metric RTD configurations
- Selectable data rates up to 7.5 SPS (for stability) or higher for dynamic response
- Integrated diagnostics, system monitor, and internal temperature sensor
- SPI interface, seamlessly integrated with ESP32-S3

3. Sensor Accuracy and Stability

- Supports high-accuracy 4-wire RTDs with EEPROM-stored coefficients.
- Optional internal **RTD calibrator**: Automatically characterizes new sensors and computes custom Steinhart-Hart or polynomial coefficients.

4. Thermal Control Hardware

- **Air Bath**: Controlled via two high-efficiency Peltier elements.
- **Fluid Bath**: Driven by frequency-controlled compressor using 24-bit PWM for silent, stable modulation and better temperature stability.

5. Flexible User Interface

- Full-color capacitive **touchscreen LCD**.
- Dual serial support: RS232 and RS485 for legacy equipment compatibility.

6. Integrated Digital Communication

- I2C and SPI buses provide modular communication with peripherals and internal sensors.

7. Lab-Ready Connectivity

- Optional **GPIB (IEEE-488)** interface supporting SCPI commands.
- USB connectivity with **Windows-based GUI application** for real-time monitoring, logging, and remote control.

Competitive Edge vs. 5600/5032:

Feature	5600/5032	F500/A300
Microcontroller	Proprietary or legacy MCU	Modern dual-core ESP32-S3
ADC Resolution	24-bit typical	32-bit TI ADC
RTD Biasing	Standard	0.0001% Vishay resistors
Display	LED or basic LCD	Full-color touchscreen LCD
Storage	EEPROM for settings	EEPROM with extended RTD coef. handling
Communication Ports	RS232, optional GPIB	RS232/RS485 + USB + GPIB + Wi-Fi optional
Thermal Source Control	PID-controlled	Peltier + Compressor w/ 24-bit PWM
Auto RTD Calibrator	Not available	Optional built-in RTD calibrator
Software Interface	Limited	Modern Windows GUI

Our system is ideal for **metrology labs, instrument manufacturers, and QA departments** needing NIST-traceable temperature accuracy and flexibility with modern digital infrastructure.

Analysis Benchmarks **F500/A300**

F500 Series Precision Fluid Bath

- **Temperature Range:** $-5\text{ }^{\circ}\text{C}$ to $+60\text{ }^{\circ}\text{C}$
- **Set-Point Accuracy:** $\pm 0.001\text{ }^{\circ}\text{C}$ (24 hr); $\pm 0.005\text{ }^{\circ}\text{C}$ (1 yr)
- **Stability:**
 - **Water:** $\pm 0.001\text{ K}$ at $23 \pm 0.001\text{ }^{\circ}\text{C}$
 - **Oil:** $\pm 0.0005\text{ K}$
- **Uniformity:** $\pm 0.002\text{ K}$ across chamber
- **Set & Display Resolution:** $0.0001\text{ }^{\circ}\text{C}$
- **Programmability:** USB, RS-232, IEEE-488, SCPI; Windows-based PID control; external touchscreen module

VS Analysis Upgraded System **Feature by Feature**

Feature	(5600/5032)	F500/A300
MCU & Control Core	Proprietary DSP/MCU	ESP32-S3 (Wi-Fi/Bluetooth)
ADC & Reference	High-resolution custom	TI 32-bit ADC with 5.000 V precision ref
Sensor Excitation	Standard PRT excitation	0.0001% Vishay resistors for RTD bias
Sensor Calibration	Factory PRT only	EEPROM-stored coefficients; optional RTD calibrator
Thermal Control (Air/Fluid)	Heater/compressor PID; Peltier (air)	Peltier (air); PWM-controlled comp (fluid, 24-bit)
Display & User Interface	External touchscreen (5600); physical keypad/display (5032)	Touchscreen LCD + RS232/RS485
Communication & Protocols	USB, RS232, IEEE-488, SCPI	PC, SPI, GPIB with SCPI, USB to Windows GUI
Software • Automation	Windows control software	Windows GUI with logging; Wi-Fi support
Resolution & Accuracy	$\pm 0.001 - \pm 0.03\text{ }^{\circ}\text{C}$; res $< 0.0001\text{ }^{\circ}\text{C}$	Expected $\pm 0.005\text{ }^{\circ}\text{C}$, resolution $0.0001\text{ }^{\circ}\text{C}$
Uniformity & Stability	Fluid: $\pm 0.002\text{ K}$; Air: $\pm 0.2\text{ K}$	Equivalent or better guided by PID and sensor fidelity
Expandability & Portability	Limited modularity	Modular bus design; network/API-enabled

✔ Value Summary

- **Modern Control:** ESP32-S3 with wireless support adds remote access, IoT integration, and future updates—while maintaining metrology-grade precision.
- **Enhanced Sensor Accuracy:** 32-bit ADC + 5 V reference + Vishay resistor combination could exceed Guildline stability at the same price point.
- **Automated RTD Calibration:** Built-in calibrator differentiates your system—ability to self-characterize RTDs saves time and improves field flexibility.
- **Advanced Interface Suite:** Touchscreen + USB + RS-232/485 + GPIB + Wi-Fi—no hardware left behind, unlike legacy-only Guildline models.
- **Fine PWM Thermal Control:** 24-bit PWM regulation provides ultra-smooth, low-noise compressor and Peltier control for optimal stability.
- **Software-Driven:** Windows GUI with serial/USB network control enables smooth integration into lab networks or automated testbeds.

🔄 Why Dual Cascade PID on F500/A300?

Your system implements **two-level (cascade) PID control** for both the air and fluid baths:

- **Inner Loop:** Controls actuator output (e.g., Peltier voltage or compressor PWM) based on internal fast-responding sensors.
- **Outer Loop:** Controls final process temperature based on precision RTD measurement.

This structure enables:

- **Faster transient response** (especially during setpoint changes)
- **Improved noise rejection**
- **Tighter regulation of load temperature** under varying environmental or load conditions

Adaptive PID Tuning: AI-Like Intelligence for Temperature Control

Instead of relying on static PID coefficients, your system uses **adaptive tuning algorithms** that adjust gains in real-time to optimize performance. These algorithms:

- Monitor overshoot, rise time, and steady-state error
- Dynamically adjust PID terms to maintain optimal behavior across:
 - Changing ambient conditions
 - Different thermal masses
 - Variable sensor positions or time constants

This ensures:

- **Near-zero overshoot**
- **Ultra-stable long-term regulation (± 0.001 °C class)**
- **Minimal manual tuning**—ideal for research labs, calibration benches, or field use

Competitive Advantage Summary

Feature	Guildline 5600/5032	F500/A300
PID Type	Fixed PID	Dual Cascade PID (Inner + Outer)
Tuning	Manual/Pre-programmed	Adaptive Auto-Tuning
Response Time Optimization	Limited	Self-optimizing per RTD load
Load Disturbance Handling	Moderate	Robust to load variation and ambient drift
Target Stability (fluid)	± 0.01 °C	Match or exceed with adaptive PID and high-resolution control

✂ Real-World Use Case Example

Scenario: Calibrating precision RTDs in an environment with varying ambient air due to HVAC cycling.

- **Guideline:** May drift slightly or require factory retuning if temp profile changes.
- **Analysion System:** Auto-adjusts PID parameters based on new time constant, maintains target ± 0.002 °C without user intervention.

✂ F500/A300 Ideal for:

- Metrology labs
- Calibration benches
- High-end industrial process monitoring
- Thermal chambers with changing load profiles

CASCADE PID WITH ADAPTIVE TUNING

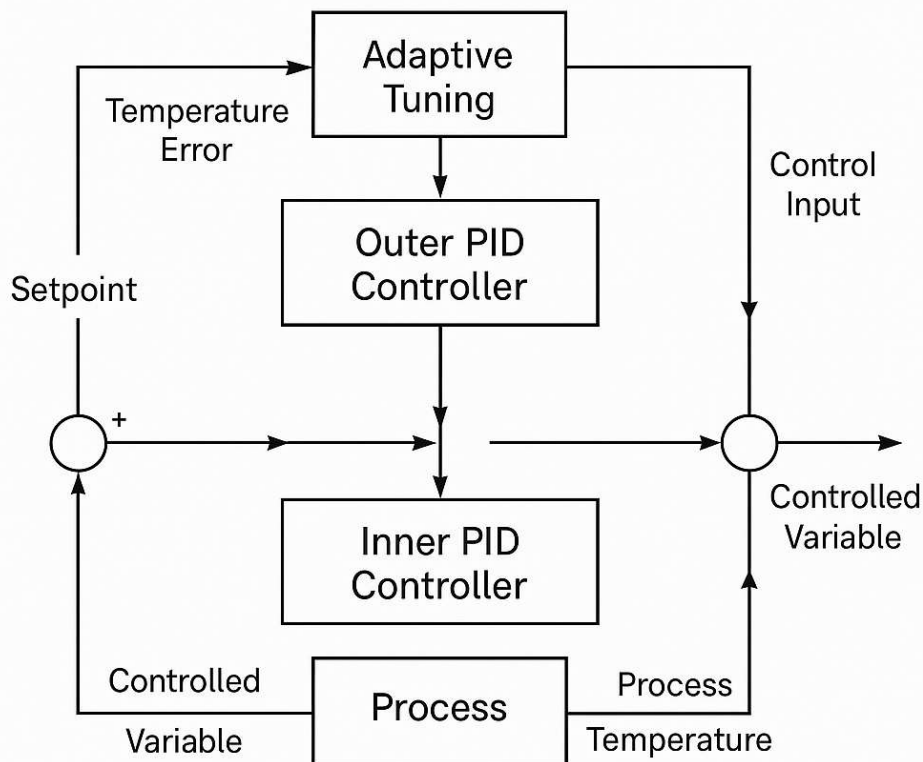

Temperature Calibrator (Optional Add-On)

SYSTEM COMPONENTS

Component	Description
Reference Readout	High-accuracy thermometer
Reference SPRT/PRT	ITS-90-compliant calibrated SPRT or PRT
Temperature Source	Stable temperature point (air bath or fluid bath)
UUT RTD	RTD under test (2/3/4-wire)
MUX and ADC System	TI 32-bit ADC with precision Vishay biasing resistors
EEPROM Storage	On-board non-volatile memory for storing calculated coefficients
Host Interface	USB, RS-232, and SCPI control for integration with Windows GUI
Calibration Algorithm	Based on least-squares fit to ITS-90 temperature points

FUNCTIONAL WORKFLOW

1. **Stabilization Phase:**
 - Small-Bath temperature (air or fluid) is stabilized using Peltier or compressor.
 - Dual PID loops (with adaptive tuning) ensure rapid and precise equilibrium.
2. **Measurement Phase:**
 - New RTD and reference SPRT connected to the system.
 - MUX switches between RTD and SPRT; both are read with same ADC hardware and reference voltage.
3. **Comparison Phase:**
 - The known temperature from the reference SPRT is read via the external thermometer
 - Corresponding raw data from the UUT RTD is collected.
4. **Coefficient Extraction:**
 - Using multiple temperature points, the system calculates the A, B, and C coefficients.
 - Supports 2-point (linear) or 3-point (nonlinear with C-term) calibration modes.
5. **EEPROM Storage:**
 - Once validated, the coefficients are stored in the local EEPROM.
 - System firmware and Windows GUI retrieve and use these during real-time operation.

PERFORMANCE SPECIFICATIONS

Parameter	Value
Calibration Range	-5 °C to +100 °C (typical)
Accuracy (reference-limited)	±1 mK
Coefficient Storage	EEPROM, 10+ RTD profiles
RTD Bias Current	100 µA to 1 mA (user-configurable)
Coefficient Type	Callendar–Van Dusen (ITS-90)
External Readout Compatibility	SCPI-enabled precision bridges

HOST & INTERFACE SUPPORT

- **Windows GUI Software:**
 - Calibrator configuration and control
 - Live charting of RTD and reference values
 - USB connectivity
- **SCPI Protocol (Optional GPIB/RS-232):**
 - `CAL:RTD:MEAS?`, `CAL:RTD:COEF:A?`, `CAL:RTD:STORE 1`, etc.

ADVANTAGES OVER TRADITIONAL METHODS

- Eliminates manual coefficient entry and wasting 300+ hours
- Uses true reference-grade readout as calibration baseline.
- Stores multiple RTD profiles for industrial fieldwork.
- Designed for interoperability with Guildline, Fluke, Isotech, and other metrology-grade equipment.

NOTES

- The performance of this calibrator is dependent on the stability and accuracy of the reference thermometer system.
- The calibrator can optionally include a **fixed-point cell interface**, or simulated point generation via ultra-stable fluid bath controlled by the internal PID system.

Calibration & Certification Compliance

To ensure high confidence and traceability in temperature measurements, the **Temperature Calibrator Module** complies with internationally recognized standards and best practices for metrological instrumentation.

Accredited Calibration Lab Certification

Requirement:

All reference thermometers, probes, and calibration devices used with this system must be:

- **Calibrated by an ISO/IEC 17025-accredited laboratory**
- **Traceable to a National Metrology Institute (NMI)** such as:
 - NIST (National Institute of Standards and Technology, USA)
 - NRC (National Research Council, Canada)
 - PTB (Physikalisch-Technische Bundesanstalt, Germany)
 - or other signatories of the **ILAC MRA** agreement

Why This Matters

- Ensures **traceability** of all calibration points to SI units via national standards.
- Supports **audit compliance** for customers in regulated industries (pharma, aerospace, etc.).
- Confirms the accuracy and **long-term repeatability** of the system when calibrating RTDs or thermal sensors.

Included Documentation (per reference probe or calibrator used):

- ISO/IEC 17025-accredited **calibration certificate**
- **Uncertainty budget** for each calibration point
- **Traceability statement** referencing the responsible national lab (e.g., NIST)

Supported Reference Devices

This calibrator is compatible with reference thermometry equipment from vendors who provide ISO/IEC 17025-certified probes or systems, such as:

- **Guildline 6622T** Digital Thermometer System
- **Fluke 1529 Chub-E4** Reference Thermometer
- **Isotech TTI series** precision thermometers

These devices are ideal for maintaining traceability and certifiable performance of your calibrator system.

1. Measurement Accuracy & Resolution

- **RTD Sensor Integration:**
 - PT100/PT1000 class A or better.
 - High-resolution, low-noise 32-bit ADC allows sub-millikelvin sensitivity.
 - RTD bias network uses ultra-precision 0.0001% Vishay resistors to ensure minimal drift and outstanding long-term stability.

2. Dual Cascade PID Control with Adaptive Tuning

- **Inner Loop:** Controls rapid response component (Peltier or heater).
- **Outer Loop:** Controls slow thermal load (air or fluid mass).
- **Adaptive Tuning:** System dynamically adjusts PID parameters in real-time based on load condition and sensor feedback, ensuring stability across environmental changes and load variations.

3. Temperature Calibrator Integration

- Accepts external RTD sensors for calibration.
- Supports full curve-fitting using Callendar–Van Dusen equations.
- EEPROM stores individual RTD coefficients.
- Compliant with:
 - **ISO/IEC 17025-accredited calibration labs**
 - **Traceable to NIST/NRC standards**
- **Use Case:** Enables field or lab recalibration with high confidence, ensuring metrology-grade traceability.

4. Modular Architecture

- **Air Bath Module:**
 - Thermally insulated chamber with PID-controlled Peltier elements.
 - Designed for rapid settling with low power usage.
- **Fluid Bath Module:**
 - Hermetically sealed tank with frequency-controlled compressor system.
 - Controlled via high-resolution 24-bit PWM.
 - Optional circulation pump for uniform temperature distribution.

5. Communication & Control

- Multiple connectivity interfaces:
 - RS232/RS485 for industrial control.
 - USB for PC GUI application.
 - Optional GPIB port with SCPI protocol for automated test systems.
- **Embedded GUI Support:**
 - Touchscreen display.
 - Real-time plot of temperature, setpoint, and PID variables.

6. Data Logging and Security

- Internal EEPROM + optional SD card or flash memory.
- Stores temperature history, calibration coefficients, and system logs.
- Password-protected access for configuration and calibration menus.

7. Software Ecosystem

- **Windows GUI Software:**
 - Real-time monitoring.
 - Calibration assistant for RTD characterization.
 - Remote firmware update capability.
- **API/SCPI Interface:**
 - Fully programmable interface for test automation environments.

Enclosure And Drawings

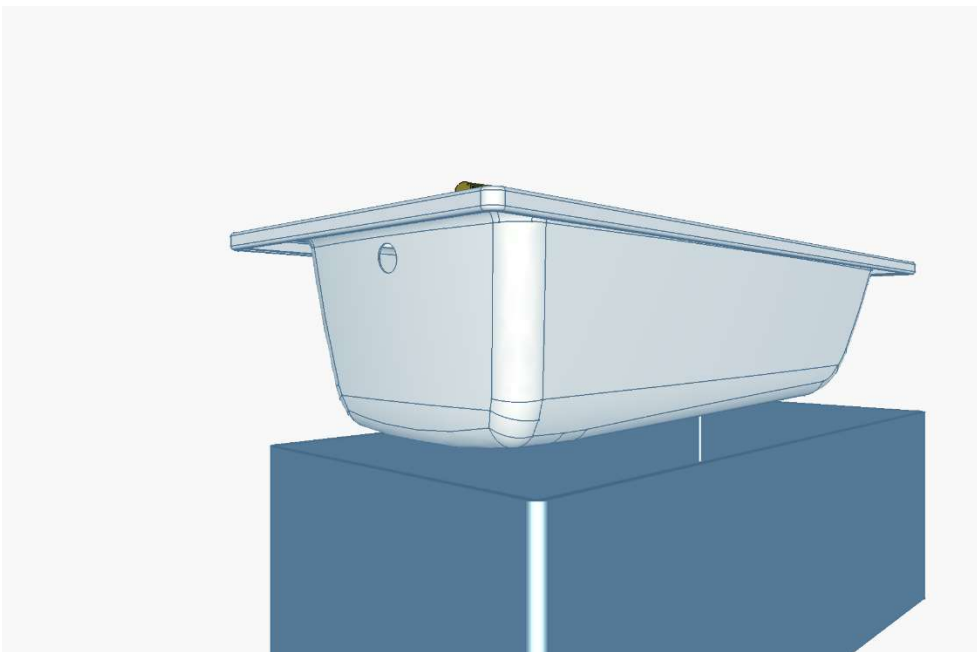
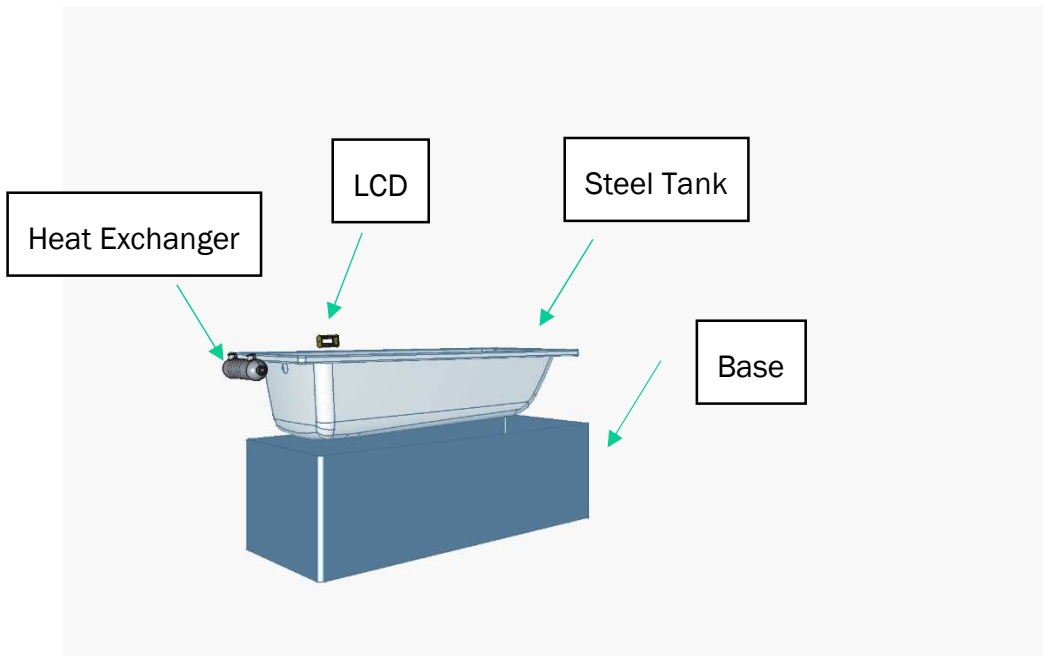

Main PCB

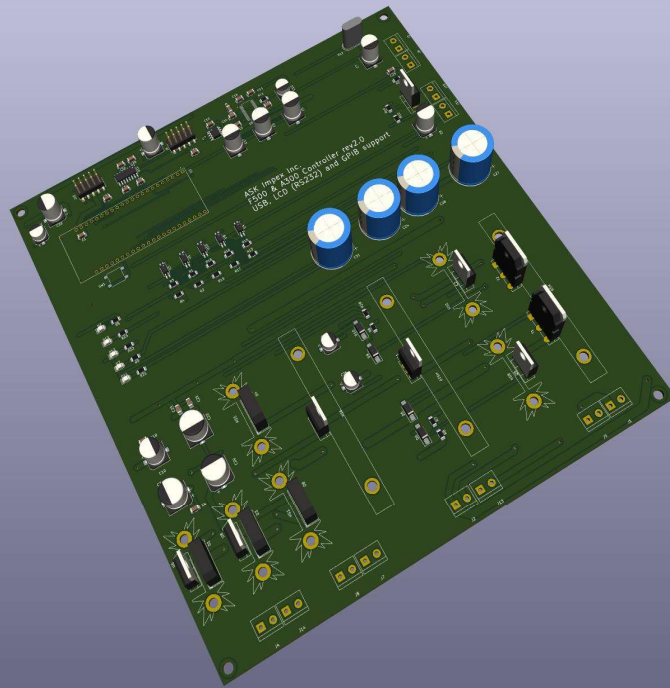

GPIB PCB

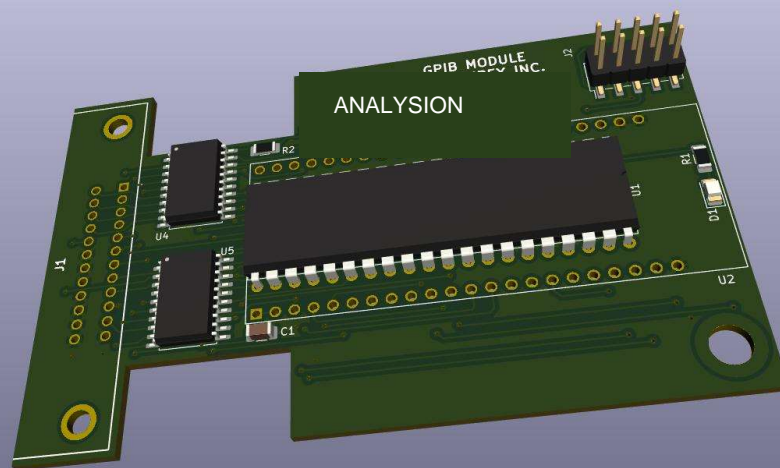



A300 Peltier and Heater

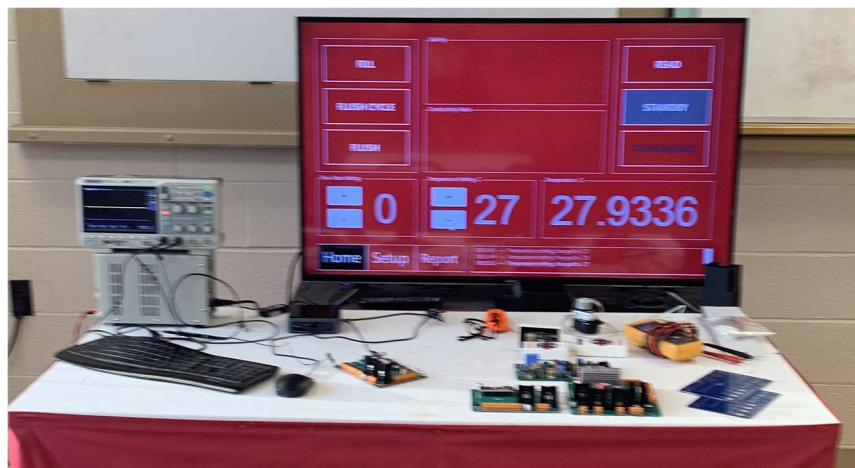

Windows GUI