



MAGNETISiM

Analysing Results: Magnet Simulation
Circuit Viewer I

GUI Overview

TAB MENU

Core Geometry Tab (Ctrl+1)

Winding Geometry Tab (Ctrl+2)

Sim Config Tab (Ctrl+3)

Magnet Tab (Ctrl+4)

INPUT FRAME

The screenshot displays the MAGNETISiM software interface. At the top, a menu bar includes 'File', 'Edit', 'Tool', and 'Help'. The main window is divided into two primary sections. On the left is the 'INPUT FRAME', which contains two main panels: 'Core Geometry' and 'Core Material'. The 'Core Geometry' panel features dropdown menus for 'Manufacturer', 'Geometry Core', and 'Core Reference', followed by input fields for dimensions A [mm], B [mm], Bp [mm], C [mm], Cp [mm], D [mm], E [mm], F [mm], G [mm], I [mm], and Gap [mm], all currently set to 0. The 'Core Material' panel includes a 'Material' dropdown, four tabs for 'Magnet', 'Power Loss', 'Electrical', and 'Thermal', and input fields for 'Real Permeability', 'Imag Permeability', and 'Conductivity', all set to 0. A button labeled 'Add Permeability(f) Curve' is present, along with a checkbox for 'Permeability(f) from Internal-Database'. On the right is the 'MODELER WINDOW', which shows a 2D grid plot with axes ranging from -0.6 to 0.6. At the bottom of the plot area are buttons for 'Export', 'Refresh Plot', and 'Fit All'. A 'BAR TOOL' is indicated at the top right of the window.

BAR TOOL

MODELER WINDOW

Core Selection

The screenshot displays the MAGNETISIM software interface. The left sidebar contains navigation icons. The main window is divided into two panels: 'Core Geometry' and 'Core Material'. The 'Core Geometry' panel includes dropdown menus for 'Manufacturer' (Ferroxcube), 'Geometry Core' (U), and 'Core Reference' (U67/27/14), along with input fields for dimensions A (5.0), B (3.0), D (2.0), E (0.6), F (5.0), and Gap (0.0). The 'Core Material' panel shows 'Material' set to 3C96, with tabs for Magnet, Power Loss, Electrical, and TH. It includes input fields for Real Permeability (2000.0), Imag Permeability (0.0), and Conductivity (0.3333333333333333), along with an 'Add Permeability(f) Curve' button and a checkbox for 'Permeability(f) from Internal-Database'. The right panel shows a 2D plot of the core geometry on a grid, with a dark blue U-shaped core and red winding patterns. The plot has axes ranging from -4 to 4. At the bottom of the plot area are buttons for 'Export', 'Refresh Plot', and 'Fit All'.

Before diving into the results, these slides briefly recap our setup.

We have configured a **U-shape geometry core with Ferroxcube 3C96 material.**

Winding Selection

The image shows two instances of the MAGNETISiM software interface. The left instance is in the 'Winding Geometry' tab, showing parameters for four separate PCB windings (w1, w2, w3, w4). The right instance is in the '2D' view, showing a 2D plot of these windings on a grid.

Left Window Parameters:

- General Winding:** Conductor Type: PCB
- PCB/Bobbin Geometry:** Left selected. Clearance XY [mm]: 0.2, Clearance Z [mm]: 0.1, Number of Layers: 3, Layer Pitch [mm]: 0.1
- Winding Geometry:** Left selected. Nturns: 1,4,1; Copper Thickness [mm]: 0.105; Width of Copper [mm]: 1.1,0.2,1.1; Pitch [mm]: 0.1; Edge [mm]: 0
- Winding Material:** Material: Copper. Magnet selected. Real Permeability: 1.0, Imag Permeability: 0.0, Conductivity: 58.0

Right Window Parameters:

- General Winding:** Conductor Type: PCB
- PCB/Bobbin Geometry:** Right selected. Clearance XY [mm]: 0.2, Clearance Z [mm]: 0.1, Number of Layers: 1, Layer Pitch [mm]: 0.2,0.2,0.2
- Winding Geometry:** Right selected. Nturns: 1; Copper Thickness [mm]: 0.175; Width of Copper [mm]: 1.0; Pitch [mm]: 1.0; Edge [mm]: 0.0
- Winding Material:** Material: Copper. Magnet selected. Real Permeability: 1.0, Imag Permeability: 0.0, Conductivity: 58.0

The 2D plot shows a central square core with four separate windings (w1, w2, w3, w4) placed around it. The plot axes range from -4 to 4 on both X and Y.

In the **Winding Geometry** tab, we defined four separate PCB windings, visually represented in the 2D modeler as w1, w2, w3, and w4.

The image displays four sequential screenshots of the MAGNETISIM software interface, illustrating the setup process for a simulation. Each window shows the 'MAGNETISIM' title bar and a menu bar with 'File', 'Edit', 'Tool', and 'Help' options.

- First Screenshot:** The 'General' tab is active. The 'Name Simulation' field contains 'MAGNETISIM_file'. The 'Magnetic Field Simulation' checkbox is checked, and the 'Electric Field Simulation' checkbox is unchecked.
- Second Screenshot:** The 'Convergence' tab is active. The 'Max Error [%]' for 'Magnetic Field Simulation' is set to '1e-08', and for 'Electric Field Simulation' it is set to '1e-05'.
- Third Screenshot:** The 'Nominal Solver' tab is active. The 'Nominal Frequency [kHz]' is set to '100'.
- Fourth Screenshot:** The 'AC Sweep' tab is active. The 'Select AC Sweep Type' is set to 'Waveform', the 'Waveform' is set to 'Square', and the 'Number of Harmonics' is set to '10'. Below the settings is a plot titled 'Actual Waveform and Harmonic Creation' showing 'Magnitude' on the y-axis (ranging from -1.0 to 1.0) and 'Time (us)' on the x-axis (ranging from 0 to 10). The plot shows a square wave (Actual Waveform) and its corresponding harmonics (Harmonics).

Finally, we ran a **Magnetic Field Simulation** using a **nominal frequency of 100 kHz** and an **AC Sweep** with a **square waveform** until the progress bar reached 100%.

Run Simulation

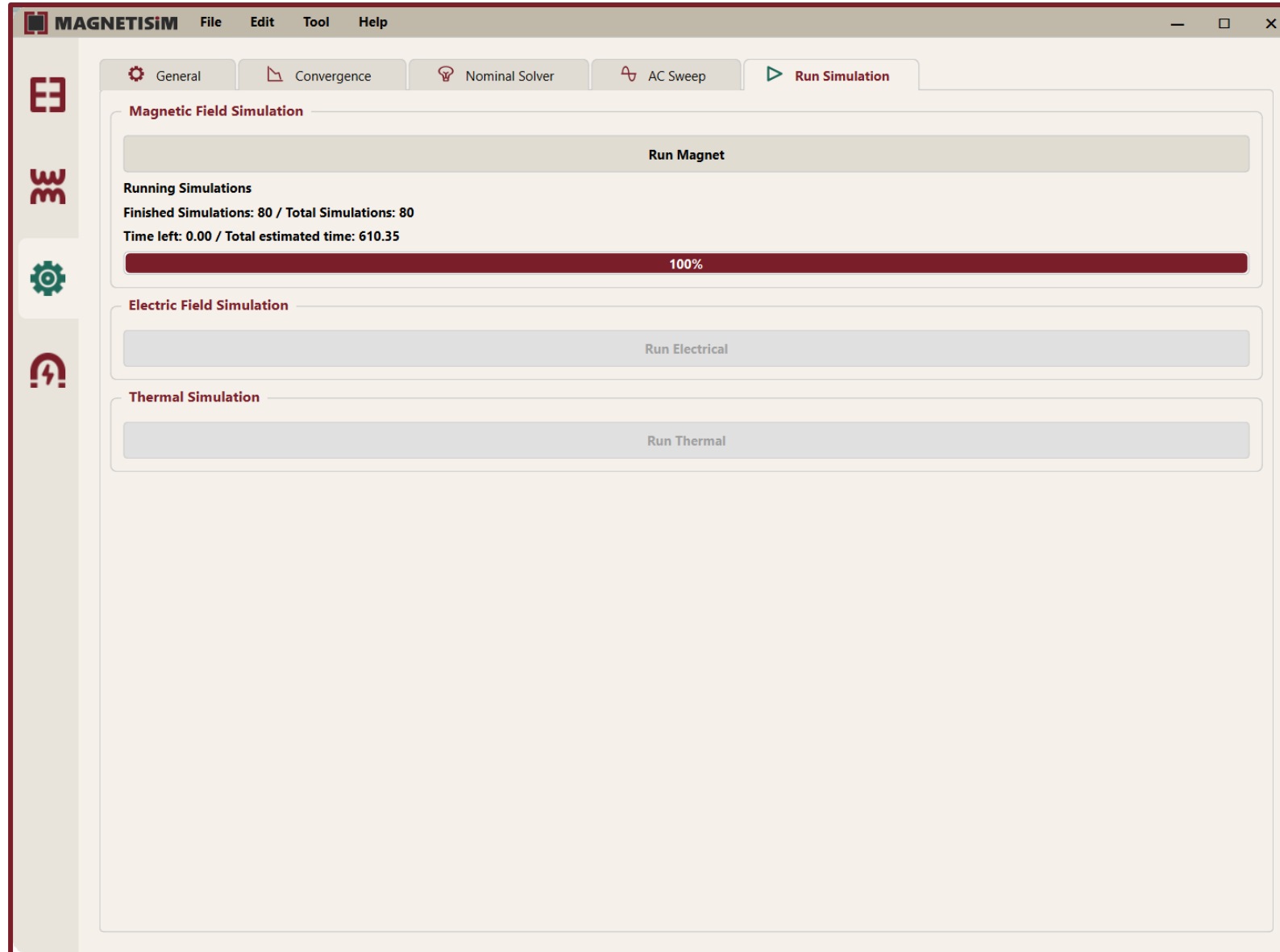

Grouping Windings

The screenshot shows the MAGNETISiM software interface. On the left, the 'Winding Expression' panel contains four winding icons labeled w1, w2, w3, and w4. A context menu is open over the w1 and w3 icons, with the option 'Define a Parallel connection' highlighted. On the right, the 'Matrix Viewer' window is active, displaying the following matrix results:

Matrix Results
Visualizer Mode: Matrix @ Freq
Selected Frequency: 100.00 kHz
Matrix Type: Z
Units: Ohm
N Decimals: 2

	w1	w2	w3	w4
w1	0.88j	3.52j	0.88j	(-0-0.87j)
w2	3.52j	(0.05+14.07j)	3.52j	(-0-3.49j)
w3	0.88j	3.52j	0.88j	(-0-0.87j)
w4	(-0-0.87j)	(-0-3.49j)	(-0-0.87j)	0.88j

Buttons at the bottom of the Matrix Viewer include 'Export CSV' and 'Export VectorFitting'.

MAGNETISiM allows you to group physical windings to reflect real-world connections.

How-to? Select windings w1 and w3 in the interface, right-click, and select "**Define a Parallel connection**".

The software automatically mathematically combines them into a single equivalent winding labeled (w1*w3).

The Matrix Equivalent

The impedance matrix calculated by the solver acts as a complete, equivalent electrical circuit. This enables the calculation of induced voltages and currents just like a physical transformer.

Active Excitation Modes

- **Voltage Source (V)** - Apply a defined Voltage to a winding terminal to observe the resulting current flow.
- **Current Source (I)** - Force a defined Current through a winding to measure the resulting voltage drop.

Passive Connections

- **Resistive Load (R)** - You do not need to actively excite every winding. You can place passive Resistors (Loads) across secondary terminals to accurately measure the induced voltages and currents passing through that load.

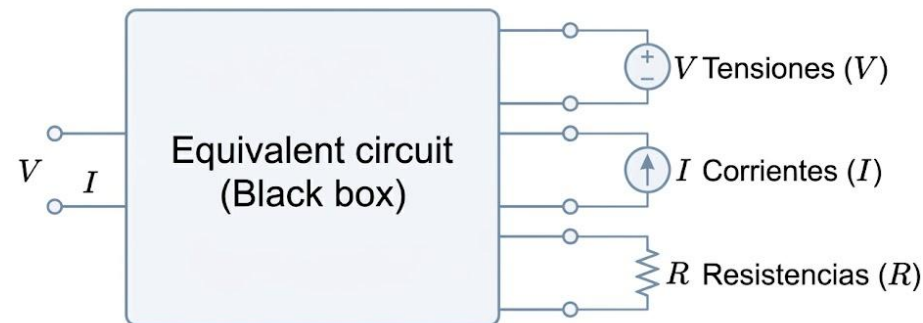

Analytical Circuit vs LTSpice Simulation

The screenshot shows the MAGNETISiM software interface. On the left, the 'Winding Expression' panel contains a 'Reset' button and three winding components labeled 'w2', 'w4', and '(w1*w3)'. On the right, the 'Circuit Results' panel displays the following data:

Frecuencia: 100.00 kHz

Winding Conf.	Excitation Type	Value
1 w2	v	100
2 w4	r	1
3 (w1*w3)	r	1

Below the table is a 'Run Circuit Sim' button. At the bottom of the interface, there are 'Export to CSV' and 'Run FEA Simulation' buttons.

	V	Mag(V)	Phase(V)	I	Mag(I)	Phas
w2	100.000-0.000j	100.000	-0.000	-12.457-7.270j	14.423	-149.
w4	-24.988-0.412j	24.991	-179.055	-24.988-0.412j	24.991	-179.
w1	25.130+0.100j	25.130	0.228	12.470+1.044j	12.514	4.7
w3	25.130+0.100j	25.130	0.228	12.659-0.944j	12.695	-4.2

The accuracy of the MAGNETISiM Circuit Viewer can be verified by comparing its analytical output against standard external SPICE solvers like LTSpice.

Test Case - By applying the exact same stimuli—a voltage source on w2, a load on w4, and a 1-Ohm load on the parallel group (w1*w3)—both platforms yield the exact same electrical response.

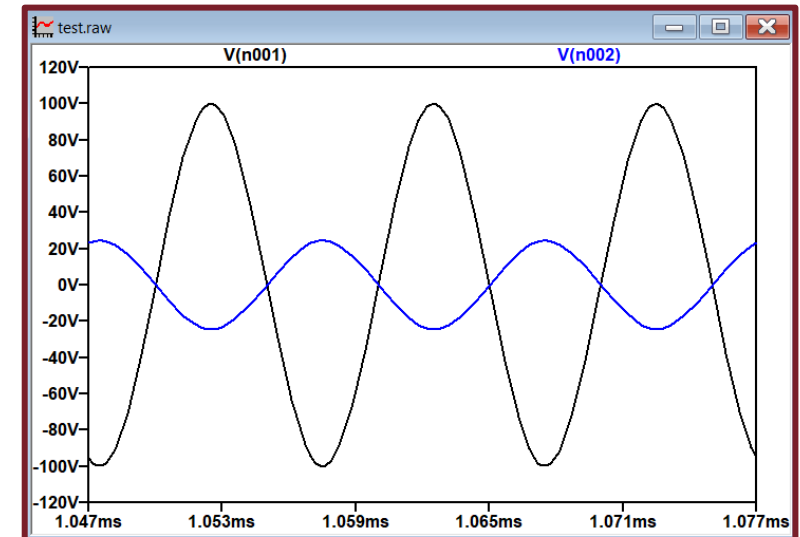

Run FEA Simulation

Once your electrical circuit parameters and loads are fully defined, run the FEA Simulation. This final step will visually and numerically confirm the internal magnetic behavior under your newly defined electrical conditions.

Run Circuit Sim

	V	Mag(V)	Phase(V)	I	Mag(I)	Phas
w2	100.000-0.000j	100.000	-0.000	-12.457-7.270j	14.423	-149.
w4	-24.988-0.412j	24.991	-179.055	-24.988-0.412j	24.991	-179.
w1	25.130+0.100j	25.130	0.228	12.470+1.044j	12.514	4.7
w3	25.130+0.100j	25.130	0.228	12.659-0.944j	12.695	-4.2

Export to CSV Run FEA Simulation

femm - [MAGNETISIM_fileA100000.0.ans]

File Edit Zoom View Operation Plot X-Y Integ

Circuit Property (Circuit2):
Name: Circuit2
Circuit Current, Amps: -12.4574089410255-I*7.269648310462147

Circuit Property (Circuit1):
Name: Circuit1
Circuit Current, Amps: 12.47009083722049+I*1.043701130835684

Circuit Property (Circuit4):
Name: Circuit4
Circuit Current, Amps: -24.98767370627887-I*0.4122661355122774

Circuit Property (Circuit3):
Name: Circuit3
Circuit Current, Amps: 12.65943458737292-I*0.9437401676652995

FEMM Output:
Title: MAGNETISIM_fileA100000.0.ans
Length Units: Millimeters
2-D Planar (Depth: 5 mm)
Frequency: 100000 Hz
14844 Nodes
29326 Elements

MAGNETISIM_fileA100000.0.fem MAGNETISIM_fileA100000.0.ans

(x=18.4000,y=4.3000)



Alberto Vital Pagola

alberto.vital@upm.es

CEIMM-UPM

Madrid, Spain



Alberto Delgado

a.delgado@upm.es

CEIMM-UPM

Madrid, Spain



magnetisim.com