



MAGNETISiM

Analysing Results: Magnet Simulation
Matrix Viewer II

GUI Overview

TAB MENU

Core Geometry Tab (Ctrl+1)

Winding Geometry Tab (Ctrl+2)

Sim Config Tab (Ctrl+3)

Magnet Tab (Ctrl+4)

INPUT FRAME

The screenshot displays the MAGNETISiM software interface. At the top, a menu bar includes 'File', 'Edit', 'Tool', and 'Help'. On the left, a vertical 'TAB MENU' contains four icons: a core symbol (Ctrl+1), a winding symbol (Ctrl+2), a gear (Ctrl+3), and a magnet symbol (Ctrl+4). The main area is divided into two sections: 'Core Geometry' and 'Core Material'. The 'Core Geometry' section includes dropdown menus for 'Manufacturer', 'Geometry Core', and 'Core Reference', followed by input fields for dimensions A [mm] through I [mm] and 'Gap [mm]', all set to 0. The 'Core Material' section features a 'Material' dropdown, tabs for 'Magnet', 'Power Loss', 'Electrical', and 'Thermal', and input fields for 'Real Permeability', 'Imag Permeability', and 'Conductivity', all set to 0. A button 'Add Permeability(f) Curve' and a checkbox 'Permeability(f) from Internal-Database' are also present. On the right, a 'MODELER WINDOW' shows a 2D plot with axes ranging from -0.6 to 0.6. At the bottom of the plot are buttons for 'Export', 'Refresh Plot', and 'Fit All'. A 'BAR TOOL' is indicated at the top right of the window.

BAR TOOL

MODELER WINDOW

Core Selection

The screenshot displays the MAGNETISIM software interface. The left sidebar contains navigation icons for Home, Settings, and Refresh. The main window is divided into two panels: 'Core Geometry' and 'Core Material'.

Core Geometry Settings:

- Manufacturer: Ferroxcube
- Geometry Core: U
- Core Reference: U67/27/14
- A [mm]: 5.0
- B [mm]: 3.0
- D [mm]: 2.0
- E [mm]: 0.6
- F [mm]: 5.0
- Gap [mm]: 0.0

Core Material Settings:

- Material: 3C96
- Real Permeability: 2000.0
- Imag Permeability: 0.0
- Conductivity: 0.3333333333333333
- Buttons: Magnet, Power Loss, Electrical, TH
- Permeability(f) from Internal-Database:

The right panel shows a 2D plot of the core geometry on a grid. The core is a dark blue U-shape with a central window. The plot axes range from -4 to 4 on both the x and y axes. The core dimensions correspond to the settings: A=5.0mm (width), B=3.0mm (height), D=2.0mm (inner width), and E=0.6mm (inner height). The plot includes 'Export', 'Refresh Plot', and 'Fit All' buttons.

Before diving into the results, these slides briefly recap our setup.

We have configured a **U-shape geometry core with Ferroxcube 3C96 material.**

Winding Selection

The image shows two instances of the MAGNETISiM software interface. The left instance is in the 'Winding Geometry' tab, showing parameters for four separate PCB windings (w1, w2, w3, w4). The right instance is in the 'General Winding' tab, showing parameters for a single winding. A 2D plot on the right shows the layout of the four windings on a grid.

General Winding (Left Window):

- Conductor Type: PCB
- PCB/Bobbin Geometry:
 - Left (selected)
 - Clearance XY [mm]: 0.2
 - Clearance Z [mm]: 0.1
 - Number of Layers: 3
 - Layer Pitch [mm]: 0.1
- Winding Geometry:
 - Left (selected)
 - Nturns: 1,4,1
 - Copper Thickness [mm]: 0.105
 - Width of Copper [mm]: 1.1,0.2,1.1
 - Pitch [mm]: 0.1
 - Edge [mm]: 0
- Winding Material: Copper
- Magnet (selected), Electrical, Thermal
- Real Permeability: 1.0
- Imag Permeability: 0.0
- Conductivity: 58.0

General Winding (Right Window):

- Conductor Type: PCB
- PCB/Bobbin Geometry:
 - Center (selected)
 - Right (selected)
 - Clearance XY [mm]: 0.2
 - Clearance Z [mm]: 0.1
 - Number of Layers: 1
 - Layer Pitch [mm]: 0.2,0.2,0.2
- Winding Geometry:
 - Left (selected)
 - Center (selected)
 - Right (selected)
 - Nturns: 1
 - Copper Thickness [mm]: 0.175
 - Width of Copper [mm]: 1.0
 - Pitch [mm]: 1.0
 - Edge [mm]: 0.0
- Winding Material: Copper
- Magnet, Electrical (selected), Thermal
- Real Permeability: 1.0
- Imag Permeability: 0.0
- Conductivity: 58.0

2D Plot:

The 2D plot shows a grid with axes ranging from -4 to 4. A dark blue rectangular area is centered at (0,0) with a width of approximately 4 units and a height of approximately 4 units. Four separate PCB windings are shown as red horizontal lines, labeled w1, w2, w3, and w4. w1 and w2 are located at approximately y = 0.5 and y = -0.5 respectively, between x = -2 and x = 2. w3 and w4 are located at approximately y = 0.5 and y = -0.5 respectively, between x = 2 and x = 4.

In the **Winding Geometry** tab, we defined four separate PCB windings, visually represented in the 2D modeler as w1, w2, w3, and w4.

The image displays four sequential screenshots of the MAGNETISIM software interface, illustrating the setup process for a simulation. Each window shows the 'MAGNETISIM' title bar and a menu bar with 'File', 'Edit', 'Tool', and 'Help' options.

- First Screenshot:** The 'General' tab is active. The 'Name Simulation' field contains 'MAGNETISIM_file'. The 'Magnetic Field Simulation' checkbox is checked, and the 'Electric Field Simulation' checkbox is unchecked.
- Second Screenshot:** The 'Convergence' tab is active. The 'Max Error [%]' for 'Magnetic Field Simulation' is set to '1e-08', and for 'Electric Field Simulation' it is set to '1e-05'.
- Third Screenshot:** The 'Nominal Solver' tab is active. The 'Nominal Frequency [kHz]' is set to '100'.
- Fourth Screenshot:** The 'AC Sweep' tab is active. The 'Select AC Sweep Type' is set to 'Waveform', the 'Waveform' is set to 'Square', and the 'Number of Harmonics' is set to '10'. Below the settings is a plot titled 'Actual Waveform and Harmonic Creation' showing 'Magnitude' on the y-axis (ranging from -1.0 to 1.0) and 'Time (us)' on the x-axis (ranging from 0 to 10). The plot shows a square wave (Actual Waveform) and its corresponding harmonics (Harmonics).

Finally, we ran a **Magnetic Field Simulation** using a **nominal frequency of 100 kHz** and an **AC Sweep** with a **square waveform** until the progress bar reached 100%.

Run simulation

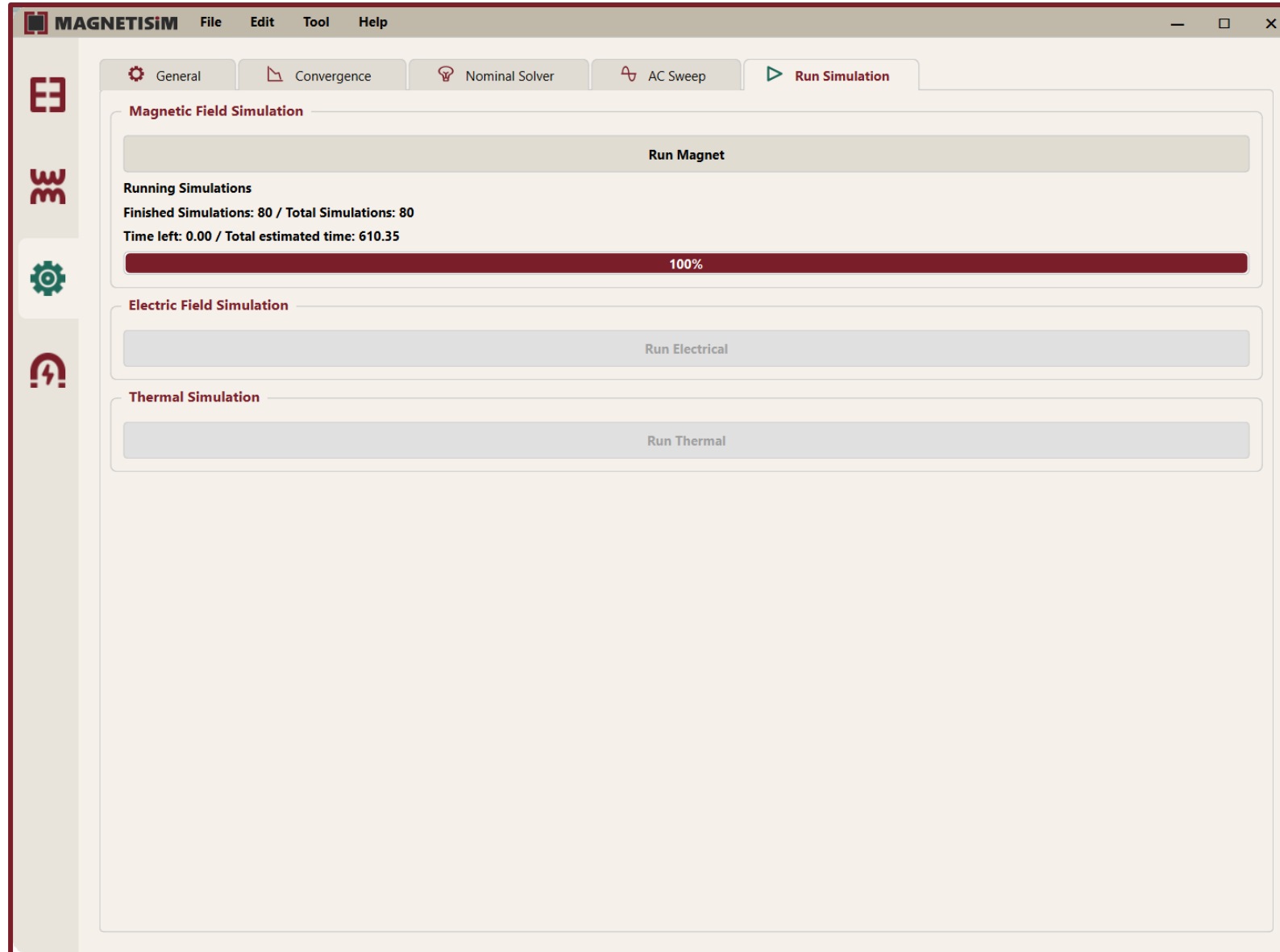

Grouping Windings

The screenshot shows the MAGNETISiM software interface. On the left, the 'Winding Expression' window contains a 'Reset' button and a workspace with four winding components labeled w1, w2, w3, and w4. A context menu is open over w1 and w3, with 'Define a Parallel connection' selected. On the right, the 'Matrix Viewer' window displays the following settings and results:

Matrix Results
Visualizer Mode: Matrix @ Freq
Selected Frequency: 100.00 kHz
Matrix Type: Z
Units: Ohm
N Decimals: 2

	w1	w2	w3	w4
w1	0.88j	3.52j	0.88j	(-0-0.87j)
2	3.52j	(0.05+14.07j)	3.52j	(-0-3.49j)
3	0.88j	3.52j	0.88j	(-0-0.87j)
w4	(-0-0.87j)	(-0-3.49j)	(-0-0.87j)	0.88j

Buttons at the bottom of the Matrix Viewer: Export CSV, Export VectorFitting

Select w1 and w3, right-click, and choose "**Define a Parallel connection**", which creates a group labeled (w1*w3).

Model Fitting

MAGNETISiM File Edit Tool Help

Winding Expression

Reset

Matrix Viewer Circuit Viewer Power Loss

Matrix Results

Visualizer Mode: Matrix @ Freq

Selected Frequency: 100.00 kHz

Matrix Type: Z

Units: Ohm

N Decimals: 2

	w2	w4	(w1*w3)
w2	(0.05+14.07j)	(-0-3.49j)	3.52j
w4	(-0-3.49j)	0.88j	(-0-0.87j)
(w1*w3)	3.52j	(-0-0.87j)	0.88j

Export CSV Export VectorFitting

When you click this, MAGNETISiM takes the complex matrices of your windings Z , L , R) across the frequency sweep and applies this algorithm. The result is usually a State-Space model or a SPICE-compatible equivalent circuit file. This allows you to take the exact, high-fidelity magnetic behavior you just simulated and immediately use it in an electrical circuit design.

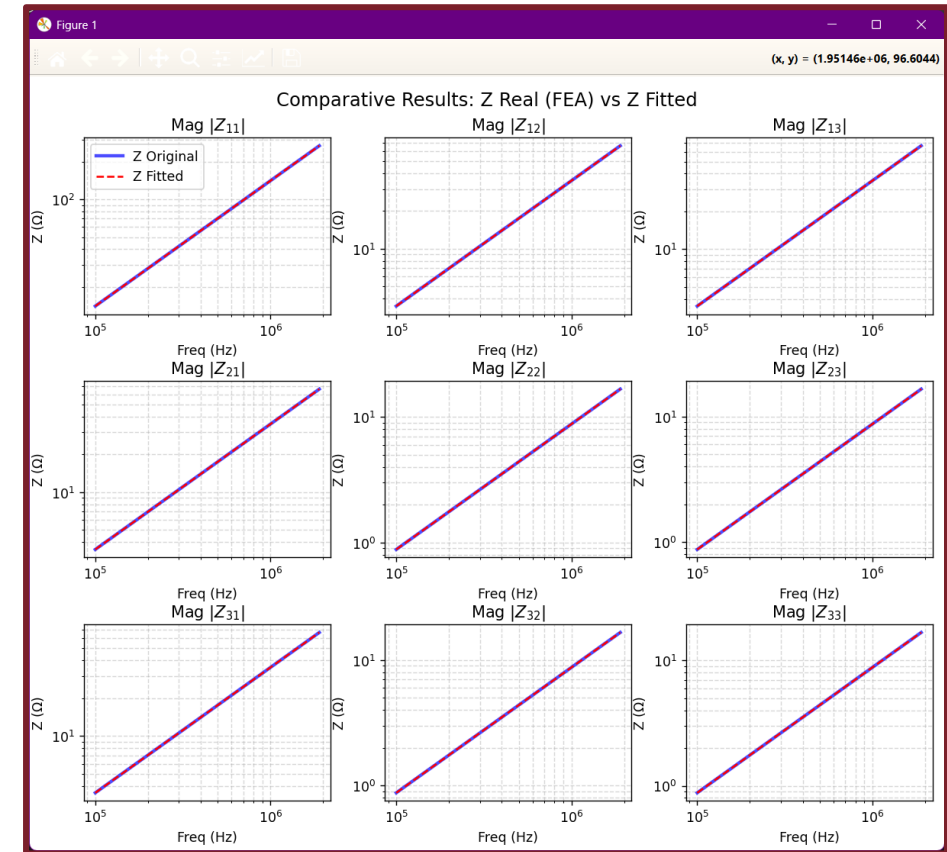

LTSpice

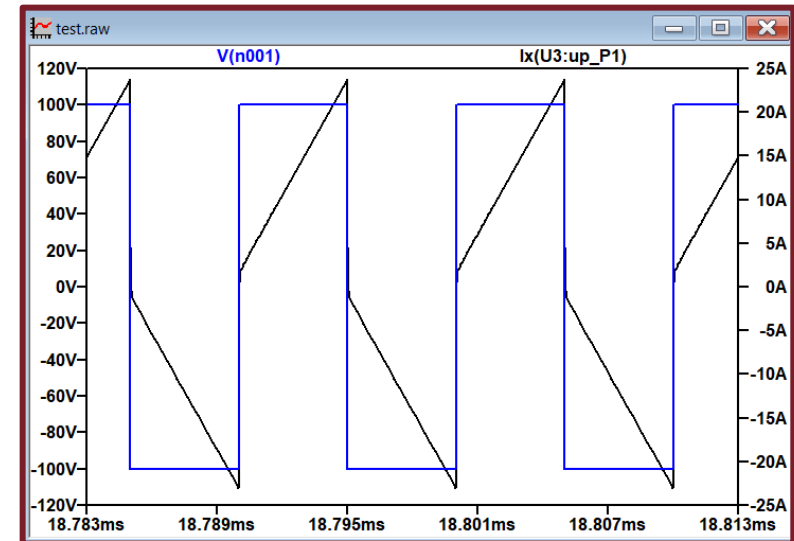
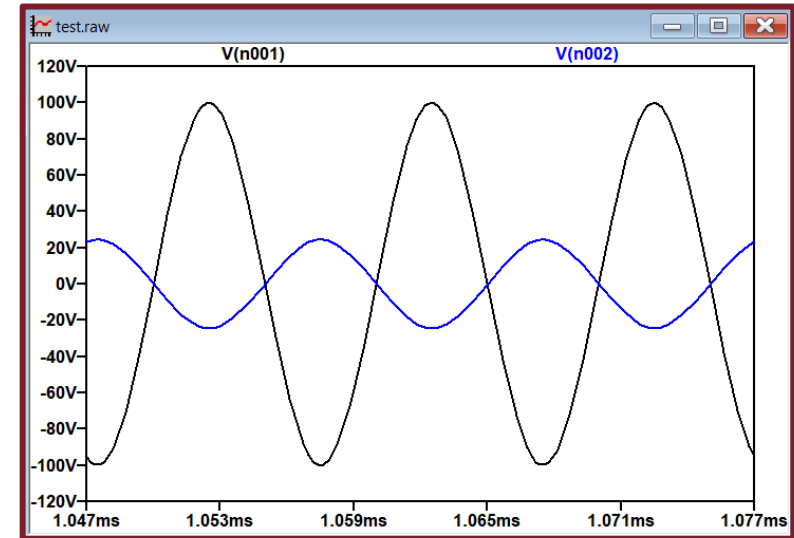
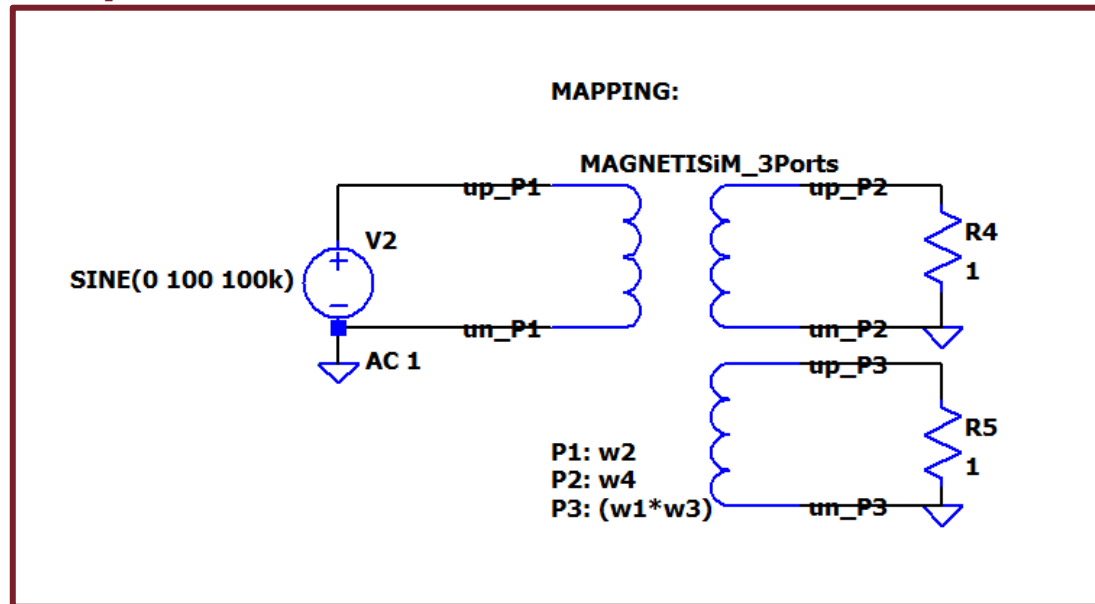



Alberto Vital Pagola

alberto.vital@upm.es

CEIMM-UPM

Madrid, Spain



Alberto Delgado

a.delgado@upm.es

CEIMM-UPM

Madrid, Spain



magnetisim.com