



# MAGNETISiM

First steps

# GUI Overview

## TAB MENU

Core Geometry Tab (Ctrl+1)

Winding Geometry Tab (Ctrl+2)

Sim Config Tab (Ctrl+3)

Magnet Tab (Ctrl+4)

## INPUT FRAME

The screenshot displays the MAGNETISiM software interface. At the top, there is a menu bar with 'File', 'Edit', 'Tool', and 'Help'. Below the menu bar is a vertical 'TAB MENU' on the left side, containing four icons: a core geometry icon, a winding geometry icon, a gear icon, and a magnet icon. The main area is divided into two sections. The left section is the 'INPUT FRAME', which is currently showing the 'Core Geometry' tab. It contains several dropdown menus for 'Manufacturer' and 'Core Reference', and a series of input fields for dimensions A [mm], B [mm], Bp [mm], C [mm], Cp [mm], D [mm], E [mm], F [mm], G [mm], I [mm], and Gap [mm], all set to 0. Below this is the 'Core Material' section, which includes a 'Material' dropdown, four tabs for 'Magnet', 'Power Loss', 'Electrical', and 'Thermal', and input fields for 'Real Permeability', 'Imag Permeability', and 'Conductivity', all set to 0. There is also a button to 'Add Permeability(f) Curve' and a checkbox for 'Permeability(f) from Internal-Database'. The right section is the 'MODELER WINDOW', which is currently showing a 2D plot with a grid. The x-axis ranges from -0.6 to 0.6 and the y-axis ranges from -0.9 to 0.9. At the bottom of the plot area, there are buttons for 'Export', 'Refresh Plot', and 'Fit All'. A 'BAR TOOL' is indicated by a line pointing to the top right corner of the window.

## BAR TOOL

## MODELER WINDOW

# Core Geometry Selection

**1** Core Geometry

Manufacturer: Select Manufacturer

Geometry Core: Select Manufacturer

Core Reference: Select Manufacturer

**2** Core Geometry

Manufacturer: Ferroxcube

Geometry Core: Select Geometry Core

Core Reference: Select Geometry Core

**3** Core Geometry

Manufacturer: Ferroxcube

Geometry Core: E

Core Reference: Select RefCore

- 1 Select the **manufacturer** from the menu (e.g., Ferroxcube).
- 2 Select the core **geometry** (e.g., the "E" model).
- 3 Select the core **reference** (e.g., E19/8/9).
- 4 The system **automatically** loads the core parameters from the built-in database.

**4** Core Geometry

Manufacturer: Ferroxcube

Geometry Core: E

Core Reference: E19/8/9

A [mm]: 19.05

B [mm]: 14.33

C [mm]: 4.75

D [mm]: 8.05

E [mm]: 5.69

F [mm]: 8.71

Gap [mm]: 0

# Core Material Selection

1

**Core Material**

Material: 3C94

**Magnet** | Power Loss | Electrical | Thermal

Real Permeability: 2300

Imag Permeability: 0

Conductivity: 0.3333333333333333

Add Permeability(f) Curve

Permeability(f) from Internal-Database

- 1 Select the **material** from the menu (e.g., 3C94). The system **automatically** loads the material parameters from the built-in database.

## CORE MATERIAL CHARACTERIZATION

- **Magnet**  
 $\mu_r' - j\mu_r''$  – Complex permeability  
Conductivity – Electrical Conductivity
- **Power Loss**  
 $k, \alpha, \beta$  – Steinmetz loss model coefficients
- **Electrical**  
Pending electrical data spec
- **Thermal**  
The thermal model will be released in September 2026.

More information in [Create Material](#)

# Modeler Window

The screenshot shows the MAGNETISIM software interface. On the left, there are two configuration panels:

- Core Geometry:** Manufacturer: Ferroxcube, Geometry Core: E, Core Reference: E19/8/9, A [mm]: 19.05, B [mm]: 14.33, C [mm]: 4.75, D [mm]: 8.05, E [mm]: 5.69, F [mm]: 8.71, Gap [mm]: 0.
- Core Material:** Material: 3C94, Magnet (selected), Power Loss, Electrical, Thermal, Real Permeability: 2300, Imag Permeability: 0, Conductivity: 0.3333333333333333, Add Permeability(f) Curve, Permeability(f) from Internal-Database (unchecked).

On the right, the **Modeler Window** displays a 2D plot of the core geometry. The plot shows a dark blue magnetic core with two rectangular cutouts. The axes range from -11 to 11 on the x-axis and -15 to 15 on the y-axis. A green arrow points to the top-right corner of the core.

Once the core and its material are configured, the **Modeler Window** allows us to confirm that everything is correctly set up.

# Modeler Window

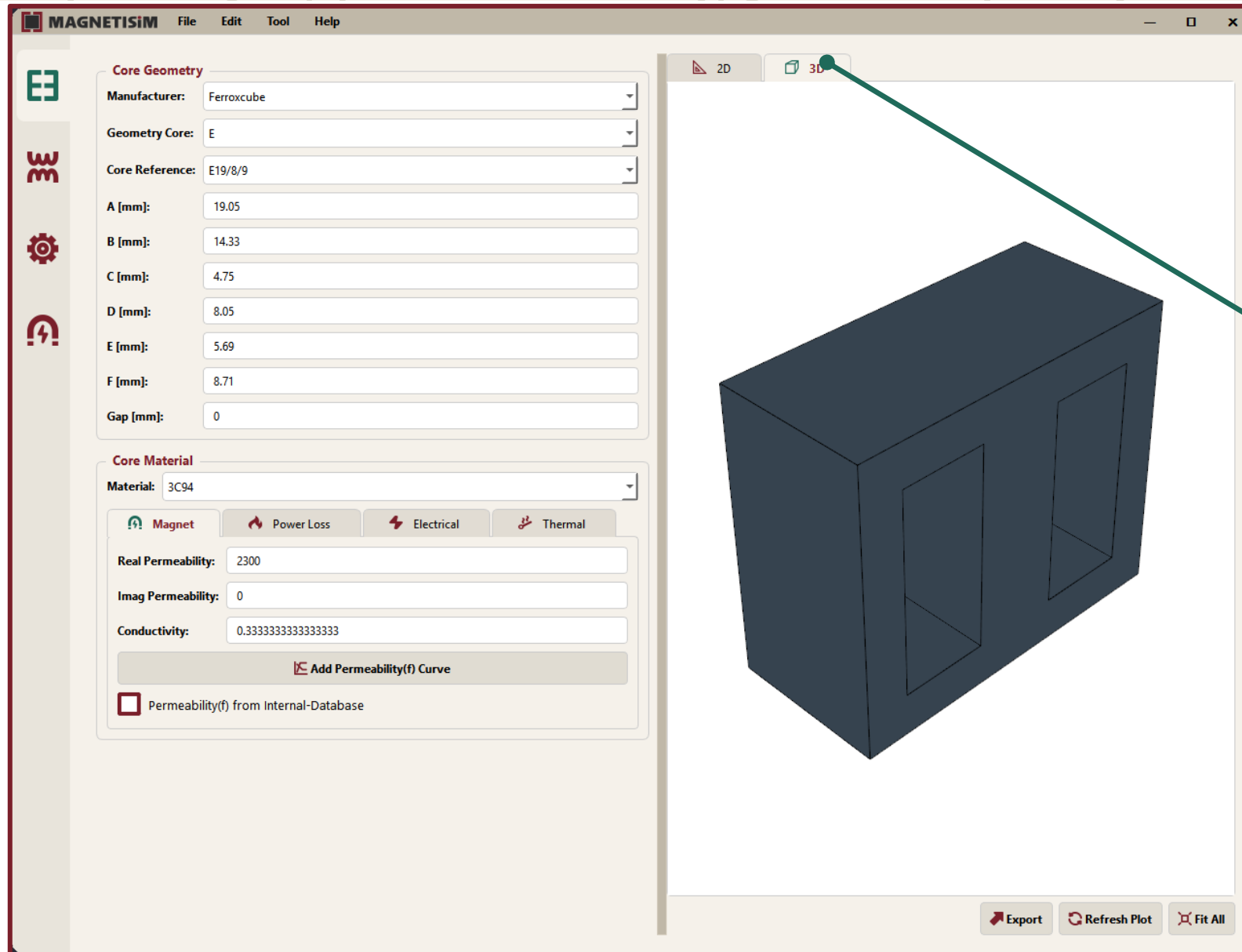

We can easily switch between a **2D view** superimposed on a grid and an **interactive 3D view** of the core we just designed.

# Winding Geometry Tab

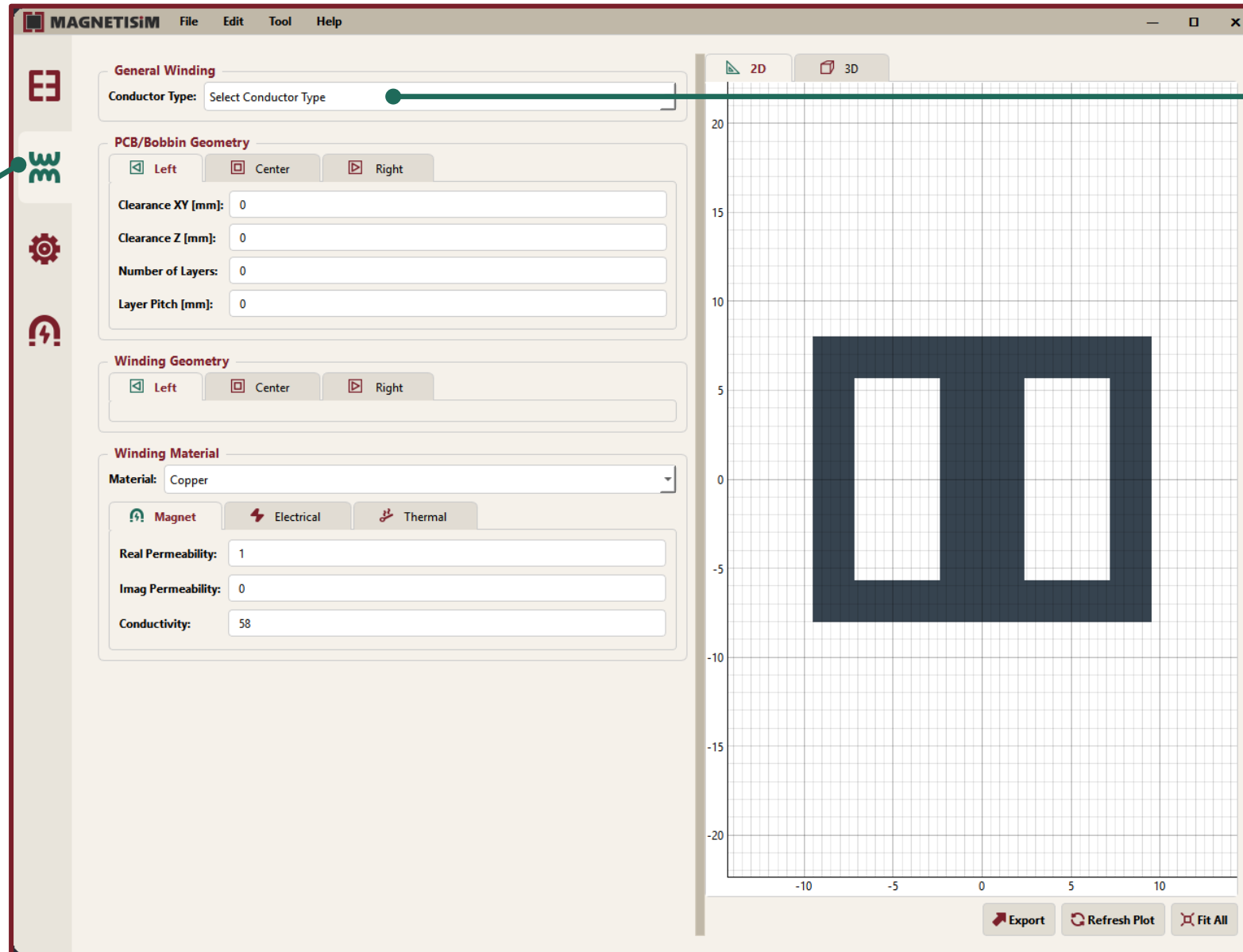

## 1 GENERAL

We choose the conductor type:

- Round
- PCB/Planar
- Litz

## WINDING GEOMETRY TAB (Ctrl+2)

Accessing the "Winding Geometry Tab" we proceed to include the coils in our design.

# Round Conductors

The screenshot shows a software interface for defining round conductors, divided into four numbered sections:

- 2 General Winding:** Conductor Type: Round
- 2 PCB/Bobbin Geometry:** Left (checked), Center, Right. Fields: Clearance XY [mm]: 0, Clearance Z [mm]: 0, Number of Layers: 0, Layer Pitch [mm]: 0.
- 3 Winding Geometry:** Left (checked), Center, Right. Fields: Distribution: V, Nturns: 0, Copper Radius [mm]: 0, Pitch [mm]: 0.
- 4 Winding Material:** Material: Copper. Magnet (checked), Electrical, Thermal. Fields: Real Permeability: 1, Imag Permeability: 0, Conductivity: 58.

## 2 PCB/BOBBIN GEOMETRY

- **Clearance XY** – This is the safety distance in the horizontal plane between the winding and the core legs.
- **Clearance Z** – This represents the separation along the vertical axis.
- **Number of layers** – Indicates the total amount of layers that will be superimposed to form the winding.
- **Layer Pitch** – This is the vertical distance or separation between one wire layer and the next one.

## 3 PCB/BOBBIN GEOMETRY

- **Distribution** – Defines the arrangement pattern of the turns (for example, a "V" vertical distribution).
- **Nturns** – The total number of turns or loops of wire that make up the winding.
- **Copper Radius [mm]** – Refers to the physical radius of the solid copper conductor.
- **Pitch [mm]** – The center-to-center distance between two consecutive turns within the exact same layer.

## 4 Winding Material

- **Magnet**
- **Electrical**
- **Thermal**

More details in [Defining Winding](#)

# Defining a Winding

**General Winding**  
Conductor Type: Round

**PCB/Bobbin Geometry**  
 Left  Center  Right  
Clearance XY [mm]: 0.5  
Clearance Z [mm]: 0.5  
Number of Layers: 1  
Layer Pitch [mm]: 0

**Winding Geometry**  
 Left  Center  Right  
Distribution: V  
Nturns: 6  
Copper Radius [mm]: 0.6  
Pitch [mm]: 0.3

**Winding Material**  
Material: Copper  
 Magnet  Electrical  Thermal  
Real Permeability: 1  
Imag Permeability: 0  
Conductivity: 58

## THE TOOL IS VERY VISUAL

When we change parameters like the layer pitch or play with the legs' position, the 2D **view updates instantly** to show us how the different layers look.

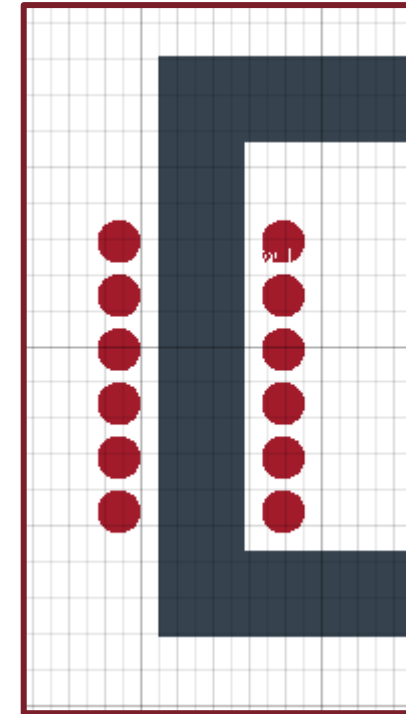

More details in [Defining Winding](#)

# Defining a Winding

**General Winding**

Conductor Type: Round

**PCB/Bobbin Geometry**

Left  Center  Right

Clearance XY [mm]: 0.5

Clearance Z [mm]: 0.5

Number of Layers: 1

Layer Pitch [mm]: 0

**Winding Geometry**

Left  Center  Right

Distribution: V

Nturns: 5

Copper Radius [mm]: 0.5

Pitch [mm]: 0.3

**Winding Material**

Material: Copper

Magnet  Electrical  Thermal

Real Permeability: 1

Imag Permeability: 0

Conductivity: 58

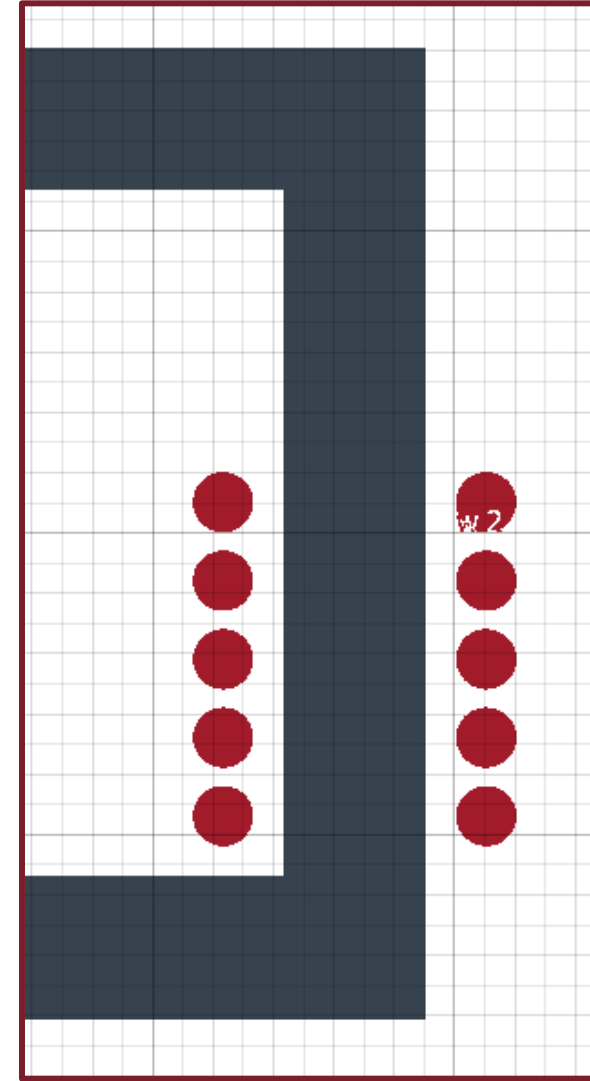
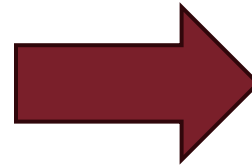

More details in [Defining Winding](#)

# This Must be the Result

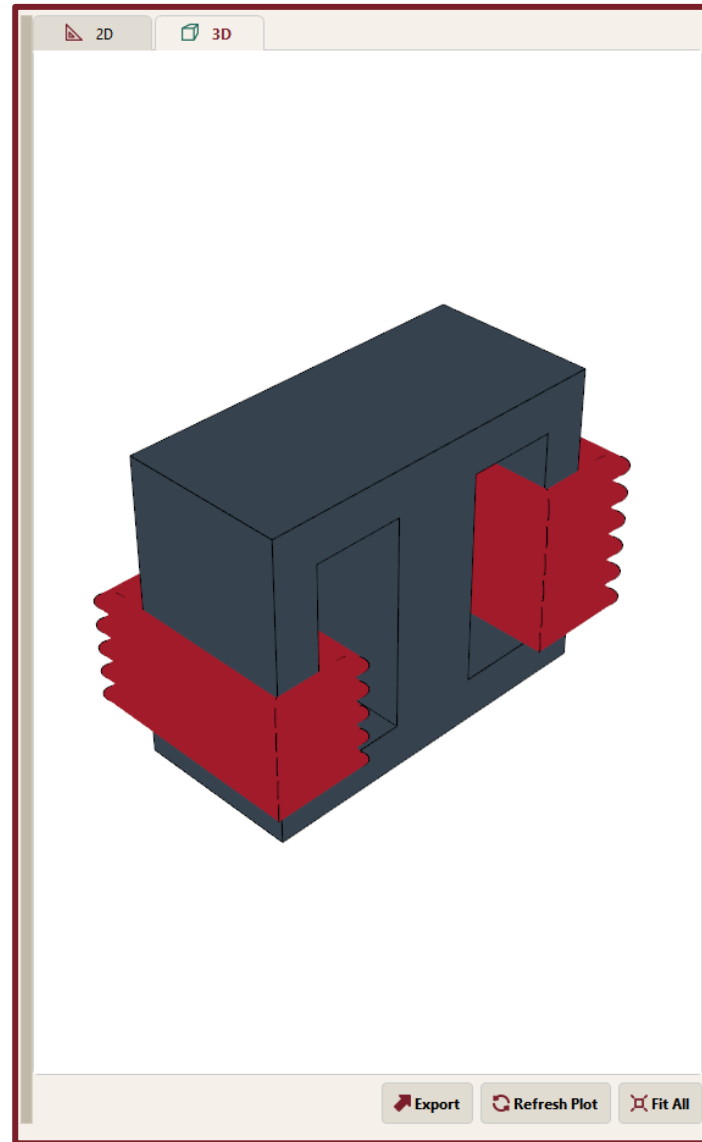

# Configure the Simulation

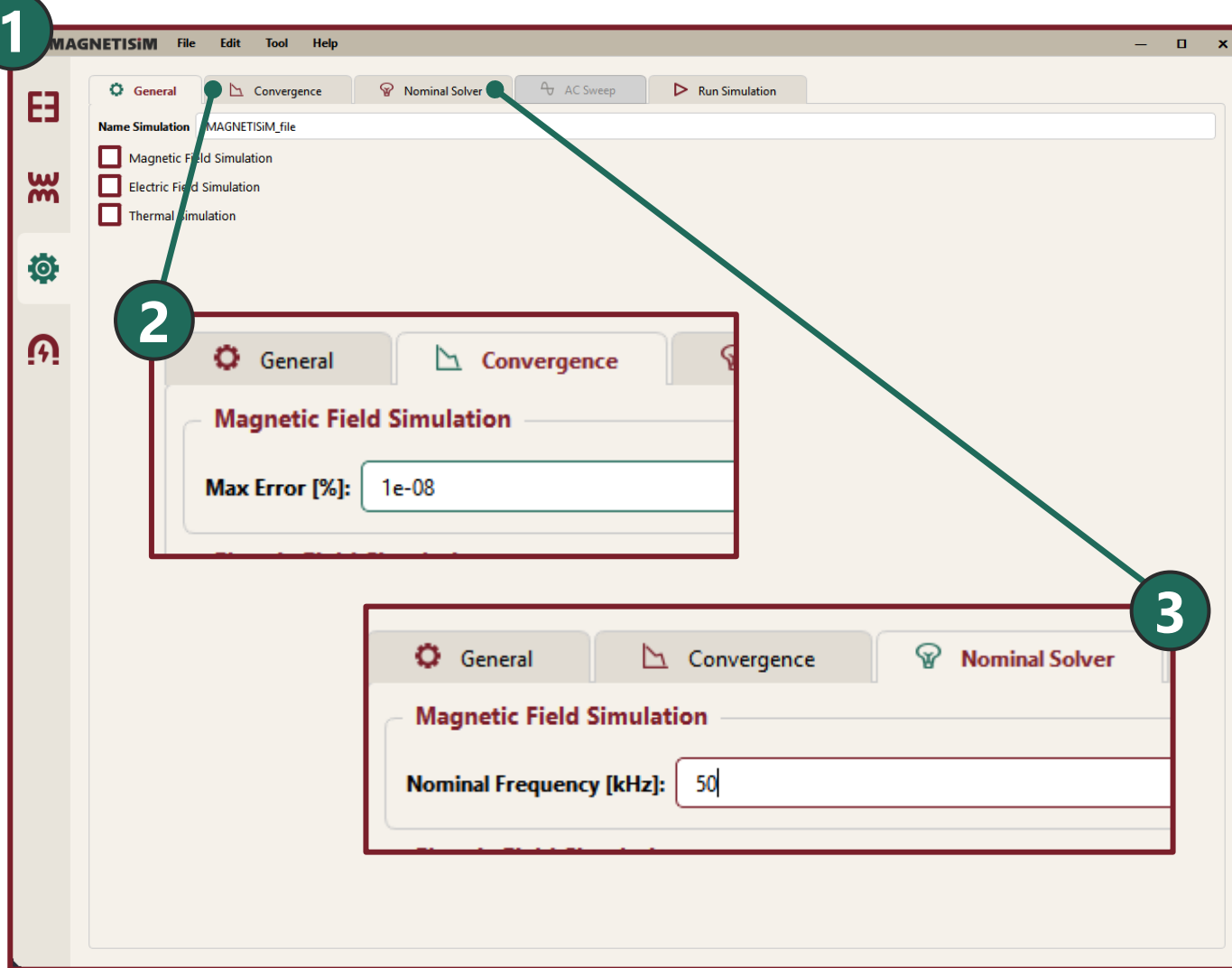

## 1 GENERAL

We assign a simulation name and select the desired simulations:

- Magnetic Field
- Electric Field
- Thermal Simulation

## 2 CONVERGENCE

We define the mathematical precision criteria, such as the maximum error.

## 3 NOMINAL SOLVER

We adjust the nominal frequency of the system.

[More details in Configure Sim](#)

# Configure the Simulation

## 4 AC SWEEP

We configure a frequency sweep, being able to select the sweep type (e.g., logarithmic) and defining the min and max frequencies to see the behavior over a broad spectrum.

## 5 RUN SIMULATION

Well, to run the simulation.

The screenshot displays the simulation configuration interface with the following settings:

- Select AC Sweep Type:** Frequency Range
- Sim Sweep Type:** Logarithmic
- Min Frequency [kHz]:** 1
- Max Frequency [kHz]:** 100
- Number of Points:** 3
- Include Nominal Frequency

The **Frequency/Waveform Plot:** section shows a plot titled "Simulation Frequency" with a logarithmic x-axis labeled "Frequency [kHz]". The x-axis has major ticks at  $10^0$ ,  $10^1$ , and  $10^2$ . Four vertical red lines with dots at the top indicate the simulation points at 1 kHz, 10 kHz, and 100 kHz.

More details in [Configure Sim](#)

# Simulating...

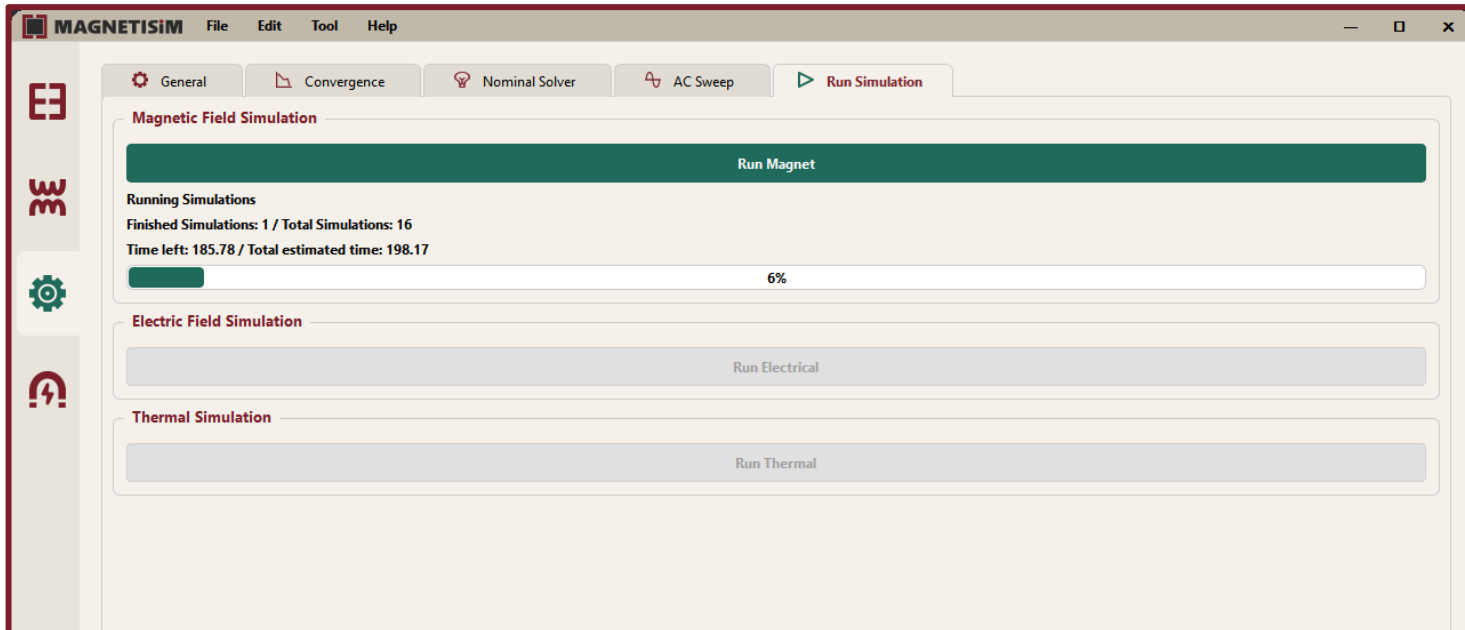

When launching the simulation in the **Run Simulation tab** (Ctrl+3), the interface locks momentarily to dedicate all resources to the field calculations.

**The development team promises this will be improved!**

You can follow the progress using a bar. Once the red bar reaches 100% and finishes counting, the results can be viewed.

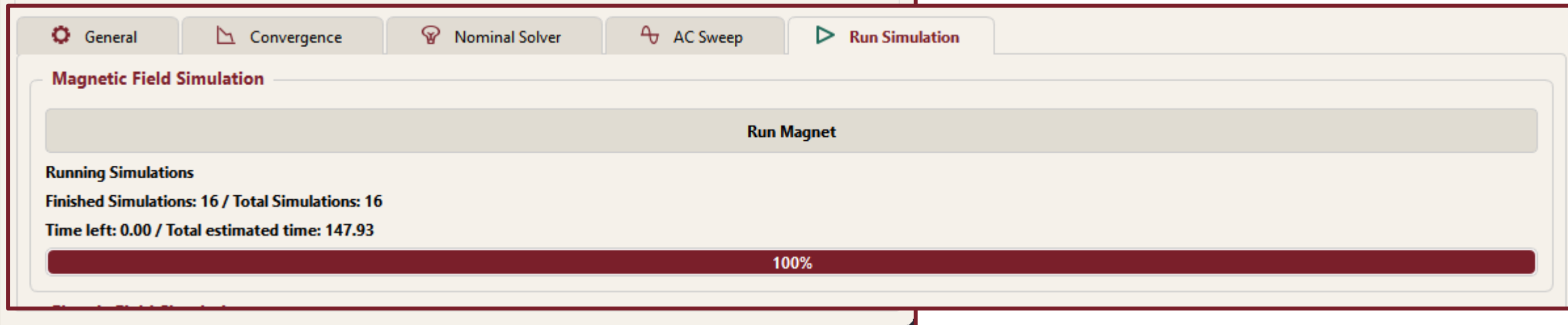

# Results Viewer (Ctrl+4)

## WINDING EXPRESSION WINDOW

In the "Winding Expression" window, we can right-click on the windings to define a series or parallel connection.

The screenshot shows the MAGNETISIM software interface. On the left, the "Winding Expression" window is active, displaying a "Reset" button and two winding components labeled "w1" and "w2". On the right, the "Matrix Viewer" window is open, showing the "Matrix Results" section. The "Visualizer Mode" is set to "Matrix @ Freq", the "Selected Frequency" is "1.00 kHz", the "Matrix Type" is "Z", the "Units" are "Ohm", and the "N Decimals" is "2". A table displays the matrix results:

	w1	w2
w1	0.43j	(-0-0.06j)
w2	(-0-0.06j)	0.3j

Buttons for "Export CSV" and "Export VectorFitting" are visible at the bottom of the Matrix Viewer window.

## RESULTS WINDOW

With the **Visualizer Mode**, we select how we want to view the data.

We can filter the data by selecting a specific frequency, the matrix type, and adjusting the units and the number of decimals plotted.

More details in [Analysing Results](#)

# Winding Connection (per layer)

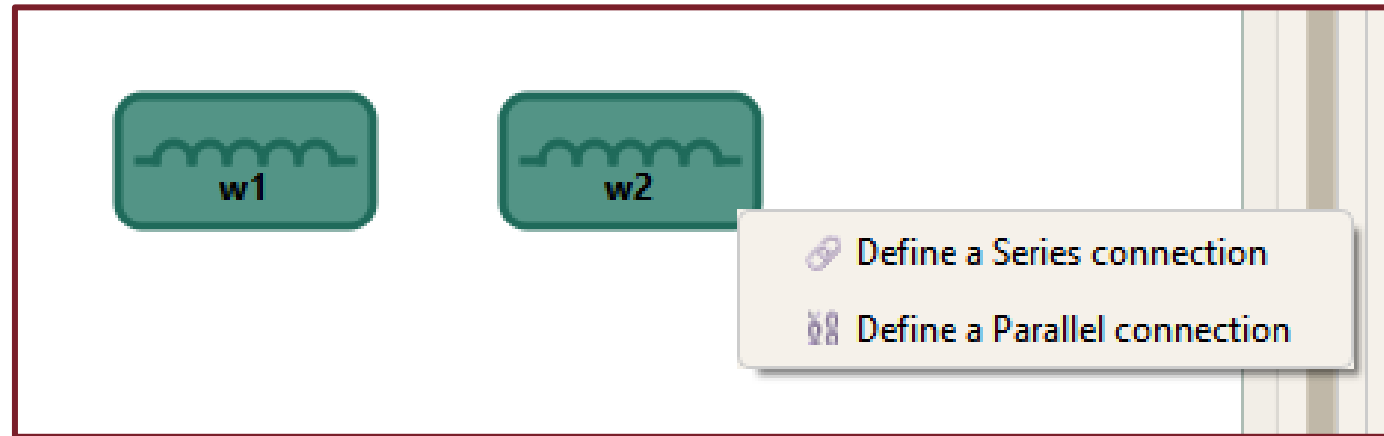

More details in [Analysing Results](#)

# Matrix Viewer

Winding Expression

Reset

Matrix Viewer

Matrix Results

Visualizer Mode: Matrix @ Freq

Selected Frequency: 1.00 kHz

Matrix Type: k

Units: 1

N Decimals: 1

	w1	w2
w1	1.0	-0.1622
w2	-0.1622	1.0

Export CSV Export VectorFitting

## 1 VISUALIZER MODE

Determines how the matrix data is presented on the screen. For example, setting it to "**Matrix @ Freq**" allows you to view the data table for one specific frequency.

## 2 SELECTED FREQUENCY

The specific frequency point (e.g., 1.00 kHz) from your simulation sweep that you want to examine in the matrix.

## 3 MATRIX TYPE

Selects the specific electrical or magnetic parameter you want to analyze. In the image, 'k' is selected, which represents the coupling coefficient between the windings.

## 4 UNITS

The physical measurement units applied to the values within the matrix. For the coupling coefficient ('k'), it is represented as a dimensionless unit ('1').

## 5 N DECIMALS

Controls the visual precision of the data by defining the exact number of decimal places shown for the numerical values inside the generated matrix.

More details in [Analysing Results](#)

# Matrix Viewer

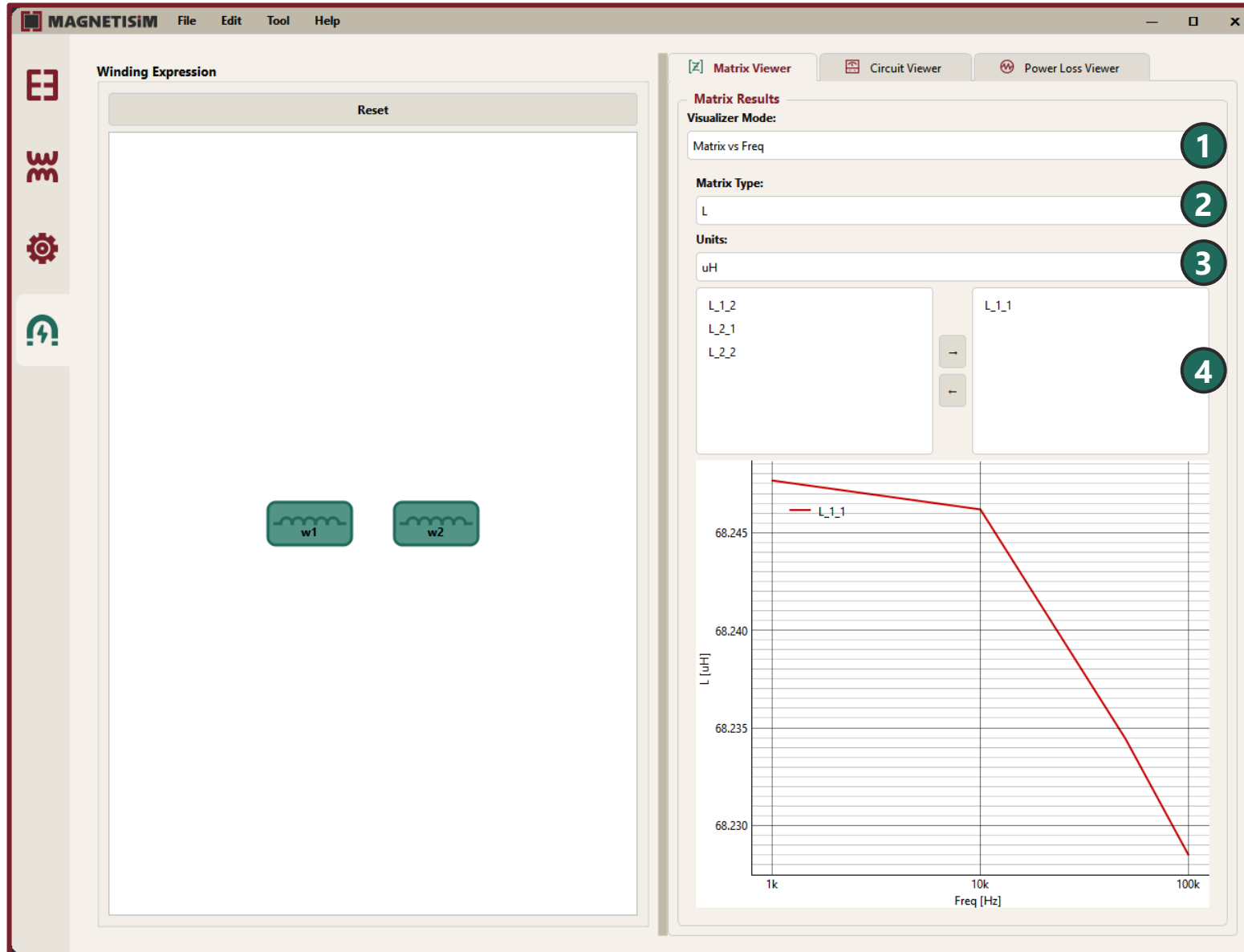

## 1 VISUALIZER MODE

Determines how to display the data. By setting it to "**Matrix vs Freq**", the viewer changes from a data table to a 2D graph, allowing you to observe how a specific parameter behaves across the entire simulated frequency range (AC Sweep).

## 2 MATRIX TYPE

Selects the specific electrical or magnetic parameter you want to evaluate. In the image provided, 'L' is selected, meaning the graph will display Inductance values.

## 3 UNITS

Sets the physical measurement unit for the graph's vertical axis (Y-axis). For the chosen inductance, it is configured to 'uH' (microhenries).

## 4 DATA TO PLOT

This selection area lets you choose exactly which elements from the matrix you want to render on the graph. You can select individual matrix components—such as a specific self-inductance or mutual inductances—and use the arrow buttons to add or remove them from the active plot.

More details in [Analysing Results](#)

**Winding Expression**

Reset

**Circuit Results**

Frecuencia: 1.00 kHz

Winding Conf.	Excitation Type	Value
1 w1	v	1
2 w2	r	1

Run Circuit Sim

	V	Mag(V)	Phase(V)	I	Mag(I)	Phase(I)
w1	1.000-0.000j	1.000	-0.000	-0.006-2.337j	2.337	-90.142
w2	-0.125-0.037j	0.130	-163.505	-0.125-0.037j	0.130	-163.505

Export to CSV Run FEA Simulation

## CIRCUIT VIEWER

The Circuit Viewer is designed for direct electrical analysis.

### 1 Frequency, Winding Conf, Excitation Type, Value

You just need to select the frequency and apply a configuration to your windings including Winding Conf, Excitation Type, and Value.

### 2 Run Circuit Sim

By clicking "Run Circuit Sim", the program returns the electrical data, solving the circuit and showing you the results layer by layer.

More details in [Analysing Results](#)

**Winding Expression**

Reset

w1 w2

**Power Loss Results**

Frecuencia: 50.00 kHz

Winding Conf.	Excitation Type	Value
1 w1	v	1
2 w2	r	1

Analytical Power Loss Simulate Power Loss

	Power Loss (W)
w1	-0.000019+0.023952j
w2	0.000043+0.000000j
Total Winding Loss	0.000024
Bpk (mT)	16.117111-0.000000j
Core Loss	0.001038

Export to CSV

## POWER LOSS VIEWER

The Power Loss Viewer is designed for direct power loss analysis.

### 1 Frequency, Winding Conf, Excitation Type, Value

Similar to the circuit viewer, you input the frequency, the excitation type, and its value.

### 2 Run Circuit Sim

Then you can calculate the losses by clicking on "Analytical Power Loss" or "Simulate Power Loss".

You will see the results broken down per layer, including total winding loss and core loss.

More details in [Analysing Results](#)



**Alberto Vital Pagola**

[alberto.vital@upm.es](mailto:alberto.vital@upm.es)

CEIMM-UPM

Madrid, Spain



**Alberto Delgado**

[a.delgado@upm.es](mailto:a.delgado@upm.es)

CEIMM-UPM

Madrid, Spain



[magnetisim.com](http://magnetisim.com)