



粤派阳光

{ 门窗 型材篇 }

Door and window profiles



影视明星
品牌代言人
李璇



中国·广州
Guangzhou, China

2025 第二版

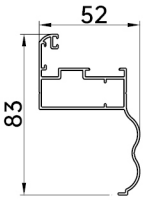
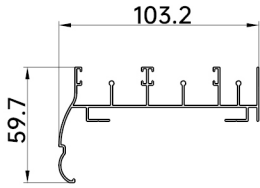
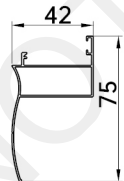
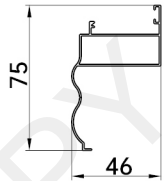
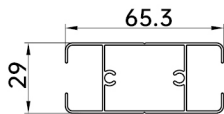

几内亚 / Guinea

No.	Drawing	Thickness /mm	Weight kg/m	No.	Drawing	Thickness /mm	Weight kg/m
LLA-001		1.0	0.998	LLA-002		1.0	0.868
LLA-003		1.0	0.878	LLA-004		1.0	1.000
LLA-005		1.0	0.918	LLA-006		0.8	0.280
LLA-007		0.9	0.452	LLA-008		0.9	0.441
LLA-009		0.9	0.455	LLA-010		1.0	0.785
LLA-011		1.0	0.712	LLA-012		0.9	0.588
LLA-013		0.9	0.562	LLA-014		0.6	0.182

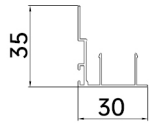
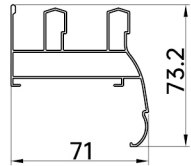
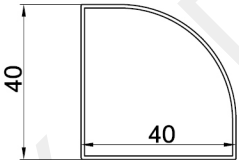
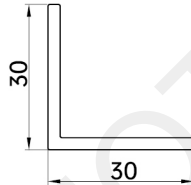
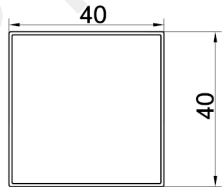
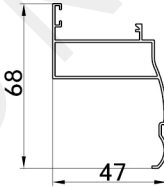
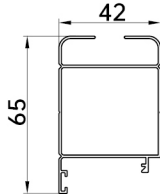
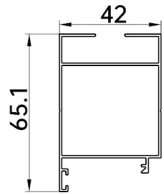

几内亚

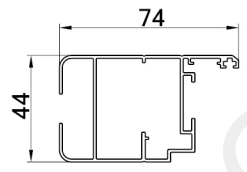
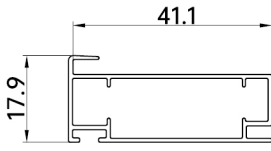
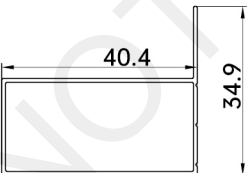
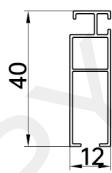
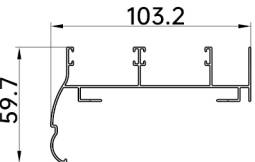
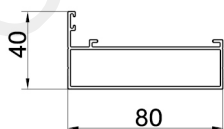
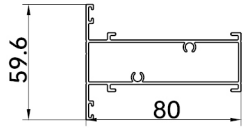
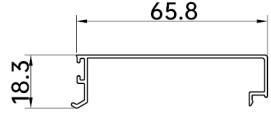
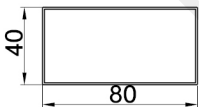
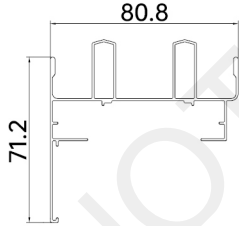
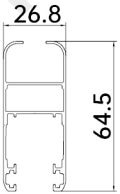
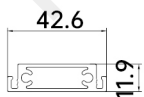
No.	Drawing	Thickness /mm	Weight kg/m	No.	Drawing	Thickness /mm	Weight kg/m
LLA-015		1.2	0.806	LLA-016		1.0	0.976
LLA-017		0.9	0.488	LLA-018		0.9	0.546
LLA-019		0.9	0.610	LLA-020		0.7	0.229
LLA-021		1.0	0.26	LLA-022		1.0	0.992
LLA-023		0.9	0.371	LLA-024		2.5	0.410
LLA-025		0.8	0.359	LLA-026		1.0	0.541
LLA-027		1.0	0.669	LLA-028		1.0	0.694

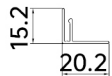
几内亚

No.	Drawing	Thickness /mm	Weight kg/m	No.	Drawing	Thickness /mm	Weight kg/m
LLA-029		1.2	0.984	LLA-030		0.8	0.308
LLA-031		0.8	0.304	LLA-032		0.8	0.252
LLA-033		1.0	0.847	LLA-034		1.3	0.886
LLA-035		1.3	1.113	LLA-036		1.0	0.334
LLA-037		1.0	0.708	LLA-038		0.9	0.90
LLA-039		1.0	0.651	LLA-040		1.4	0.534
LLA-041		0.7	0.093	LLA-042		0.9	0.114

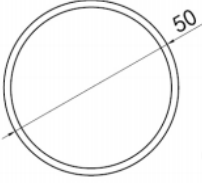
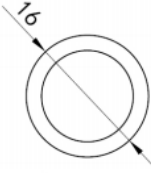
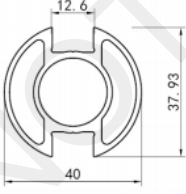
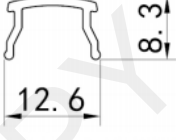
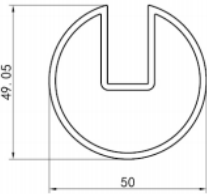
加纳 / Ghana

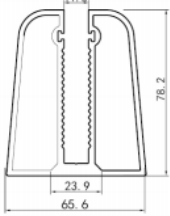
No.	Drawing	Thickness /mm	Weight kg/m	No.	Drawing	Thickness /mm	Weight kg/m
25GOAC01		2.0	0.823	25GOAC02		2.0	0.240
25GOAC03		1.5	0.953	25GOAC04		1.2	0.076
25GOAC05		2.0	1.090	25GOAC06		2.5	2.340
25GOAC07		2.5	2.880	25GOAC08			
25GOAC09				25GOAC10			
25GOAC11				25GOAC12			
25GOAC13				25GOAC14			

科特迪瓦

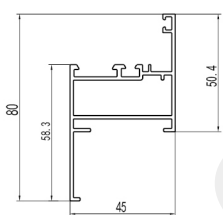
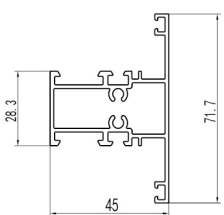
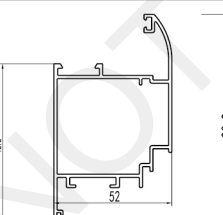
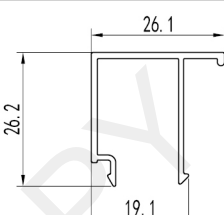
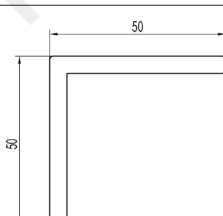
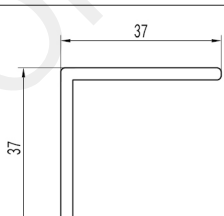
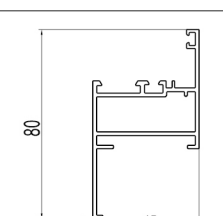
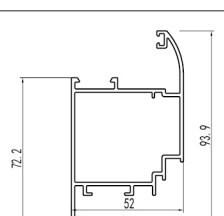
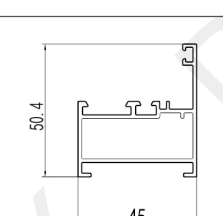
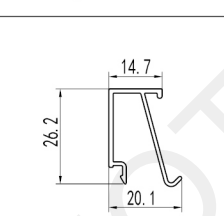
No.	Drawing	Thickness /mm	Weight kg/m	No.	Drawing	Thickness /mm	Weight kg/m
KTP-01		1.4	0.973	KTP-02		1.4	1.090
KTP-03		1.4	1.220	KTP-04		1.4	0.265
KTP-05		4.9	1.350	KTP-06		2.7	0.57
KTP-07		1.6	1.063	KTP-08		1.6	1.327
KTP-01A		1.4	0.780	KTP-04A		1.2	0.226
KTP-11				KTP-12			
KTP-13				KTP-14			

肯尼亚

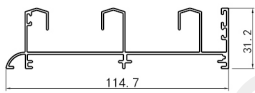
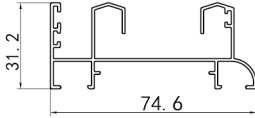
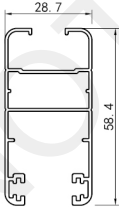
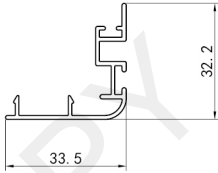
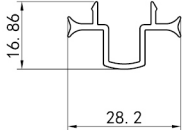
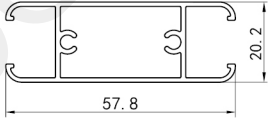
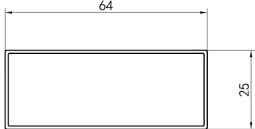
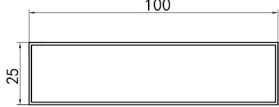
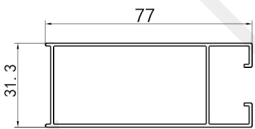
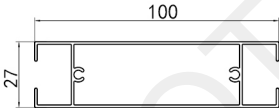
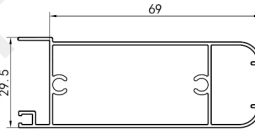
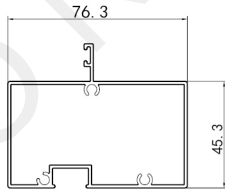
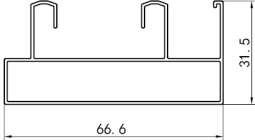
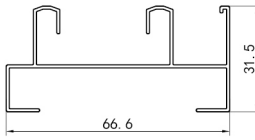
No.	Drawing	Thickness /mm	Weight kg/m	No.	Drawing	Thickness /mm	Weight kg/m
E001		1.0	0.960	E002		1.0	0.670
E003		1.0	0.650	E004		1.1	0.310
E005		1.3	0.225	T23		1.1	0.560
T24		1.3	0.225	T25		1.3	0.225
D001		1.1	0.695	D002		1.1	0.891
D003		1.0	0.706	D004		1.3	0.108
W001		0.9	0.586	W002		0.9	0.470

肯尼亚

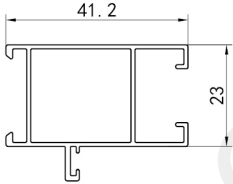
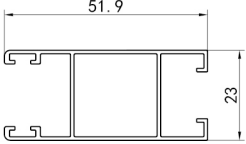
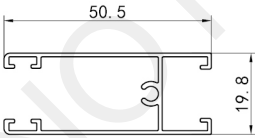
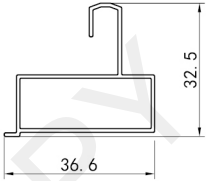
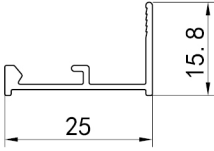
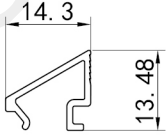
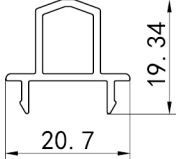
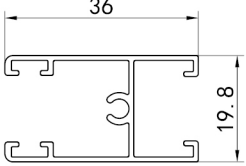
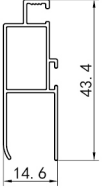
No.	Drawing	Thickness /mm	Weight kg/m	No.	Drawing	Thickness /mm	Weight kg/m
W003		0.9	0.390	W004		0.9	0.437
W005		0.9	0.390	W006		0.9	0.294
W007		1.1	0.142	W008		1.1	0.110
W009		1.2	0.208	W010		0.9	0.318
N002		0.8	0.263	E001			
E001				E001			
E001				E001			

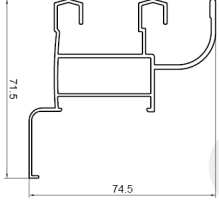
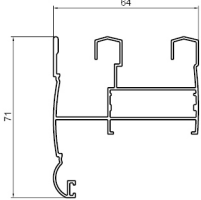
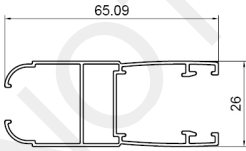
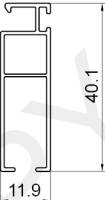
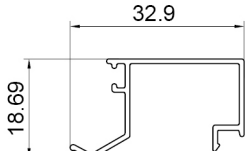
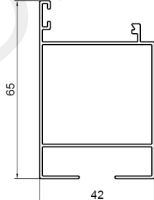
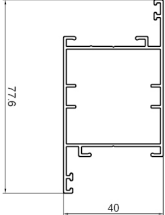
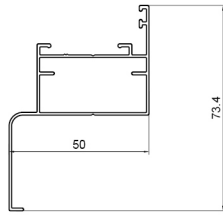
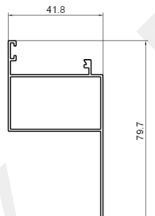
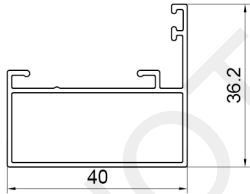
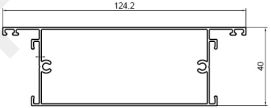
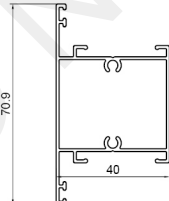
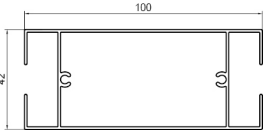
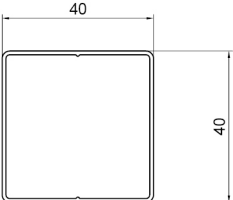

马里

No.	Drawing	Thickness /mm	Weight kg/m	No.	Drawing	Thickness /mm	Weight kg/m
MLW-01		1.9	1.090	MLW-02		1.9	0.985
MLW-03		0.9	0.567	MLW-04		0.9	0.277
MLW-05		1.0	0.203	MLW-06		1.0	0.700
MLW-07		1.1	0.805	MLW-08		0.9	0.580
MLW-09		1.0	0.583	MLW-10		1.0	0.444
MLW-11		1.1	1.070	MLW-12		1.0	0.732
MLW-13		1.1	1.120	MLW-14		1.0	0.440

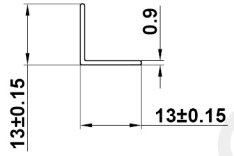
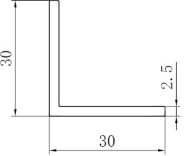
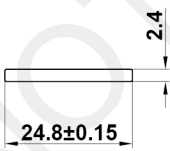
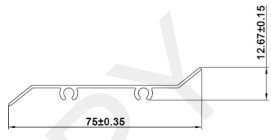
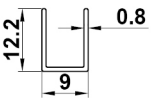
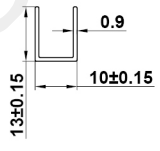
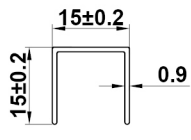
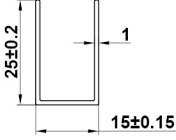
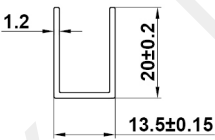
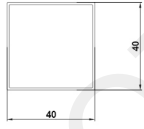
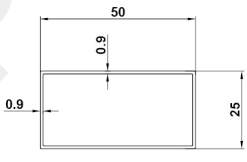
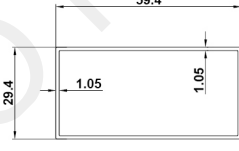
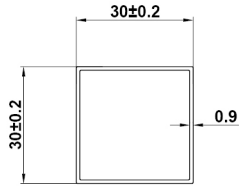
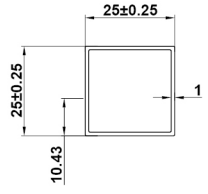
玻利维亚

No.	Drawing	Thickness /mm	Weight kg/m	No.	Drawing	Thickness /mm	Weight kg/m
BLWY-101		0.9	0.061	BLWY-106		2.5	0.390
BLWY-108		2.4	0.162	BLWY-116		1.0	0.298
BLWY-160A		0.8	0.070	BLWY-160B		0.9	0.084
BLWY-163		0.9	0.105	BLWY-164		1.0	0.253
BLWY-165		1.2	0.167	BLWY-204		1.0	0.424
BLWY-251		0.9	0.357	BLWY-252		1.05	0.493
BLWY-253		0.9	0.284	BLWY-254		1.0	0.261

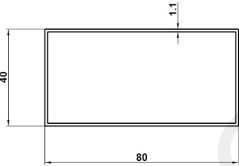
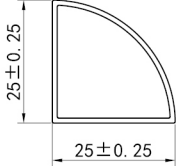
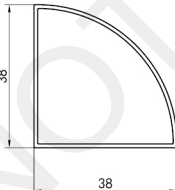
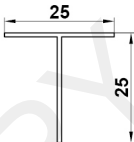

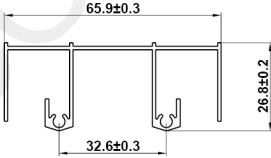
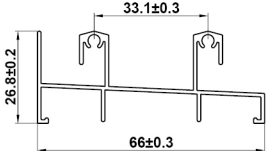
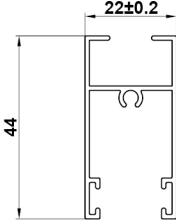
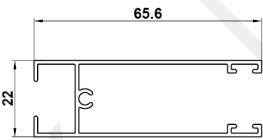
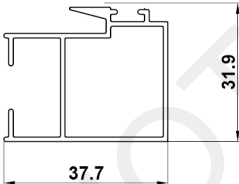
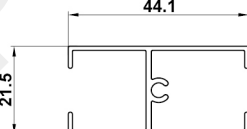
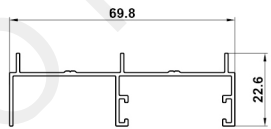
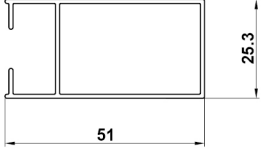
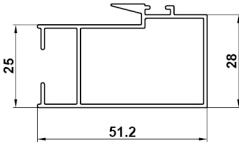

玻利维亚

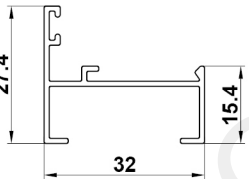
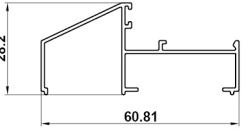
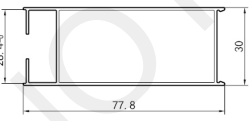
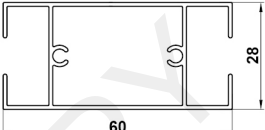
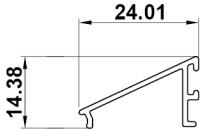
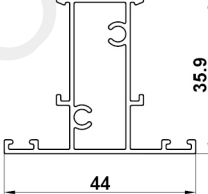
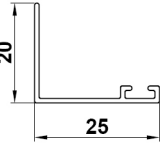
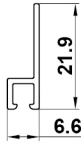
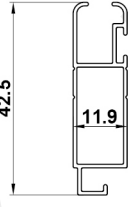
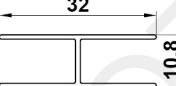
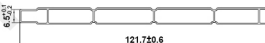
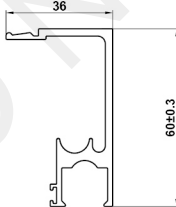
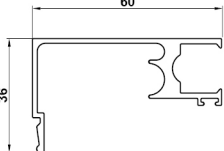
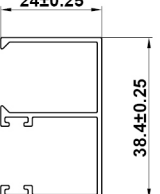
No.	Drawing	Thickness /mm	Weight kg/m	No.	Drawing	Thickness /mm	Weight kg/m
BLWY-255		1.2	0.705	BLWY-280		1.0	0.233
BLWY-283		1.0	0.361	BLWY-322		1.0	0.127
BLWY-1202		1.0	0.209	BLWY-2501		1.05	0.597
BLWY-2502		1.05	0.568	BLWY-2504		1.05	0.408
BLWY-2505		1.05	0.529	BLWY-2507		1.05	0.458
BLWY-2508		1.0	0.385	BLWY-2509		1.05	0.440
BLWY-2510		1.05	0.458	BLWY-2511		1.0	0.546

玻利维亚

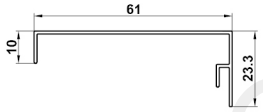
No.	Drawing	Thickness /mm	Weight kg/m	No.	Drawing	Thickness /mm	Weight kg/m
BLWY-3501		1.0	0.253	BLWY-3501		1.0	0.385
BLWY-3502		1.0	0.630	BLWY-3503		1.0	0.603
BLWY-3504		1.0	0.131	BLWY-3505		1.0	0.476
BLWY-5004		0.9	0.126	BLWY-5005		1.1	0.102
BLWY-5310		0.8	0.252	BLWY-5316		0.9	0.181
BLWY-5322		0.6	0.463	BLWY-8001A		2.5	0.934
BLWY-8001B		1.5	0.759	BLWY-8002		1.05	0.352

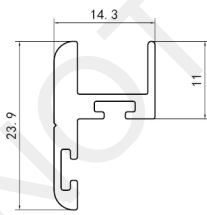

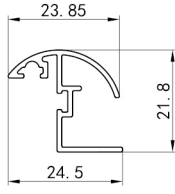

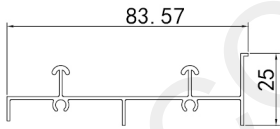
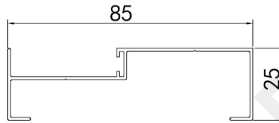
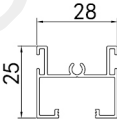
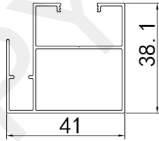
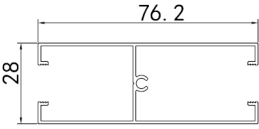
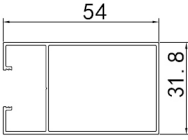
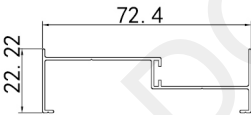
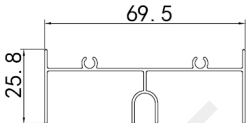
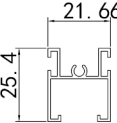
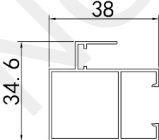
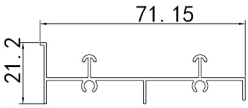
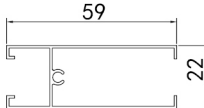

玻利维亚

No.	Drawing	Thickness /mm	Weight kg/m	No.	Drawing	Thickness /mm	Weight kg/m
BLWY-8003		0.9	0.252	BLWY-8003XIN		0.9	0.263
BLWY-TK7		1.0	0.270	BLWY-TK8		1.0	0.603
BLWY-TK10		1.0	0.217	BLWY-3505			
BLWY-5004				BLWY-5005			
BLWY-5004				BLWY-5005			
BLWY-5004				BLWY-5005			
BLWY-5004				BLWY-5005			

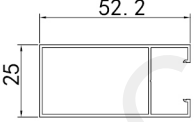

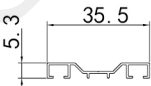
马来西亚

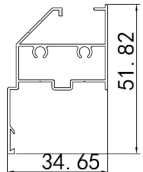
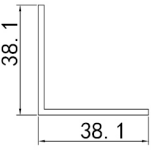
No.	Drawing	Thickness mm	Weight kg/m	No.	Drawing	Thickness mm	Weight kg/m
SLD2747S		1.0	0.5	SLD2749S		1.0	0.445
SLD2751S		0.95	0.304	SLD2752S		0.95	0.504
SLD 2753S		1.0	0.611	SLD2754S		0.95	0.49
SLD 2170S		0.9	0.338	SLD 2171S		0.9	0.42
SLD 2173S		0.9	0.26	SLD 2174S		0.9	0.395
SLD 2175S		0.9	0.375	SLD 2178S		0.9	0.41

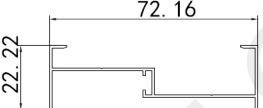
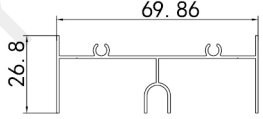
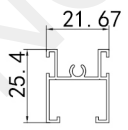
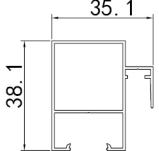
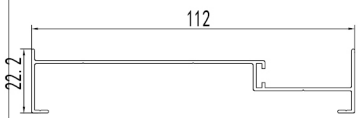
马来西亚

No.	Drawing	Thickness mm	Weight kg/m	No.	Drawing	Thickness mm	Weight kg/m
SLD 2179S		0.9	0.4	UC050309		0.9	0.09
SK6001SS		0.7	0.124	EA080808		0.8	0.109
CW1375SSKT		0.8	0.407	EA121220		2.0	0.405
RT08		0.9	0.154	SD170A		0.9	0.331
SD171A		0.9	0.435	SD173A		0.9	0.254
SD174A		0.9	0.395	SD180		1.05	0.511

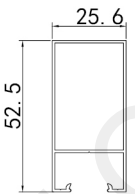
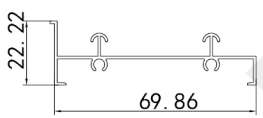
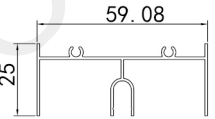
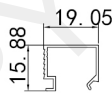
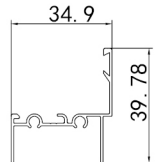
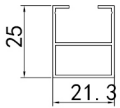
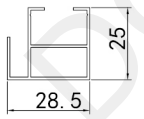
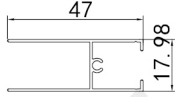
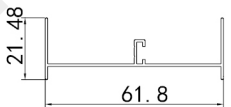

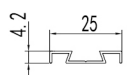
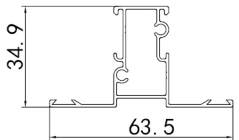

马来西亚

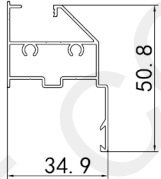
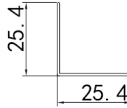
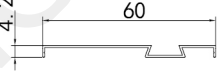
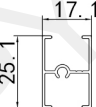
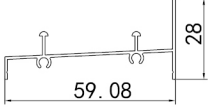
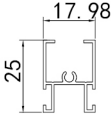
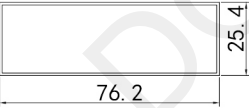
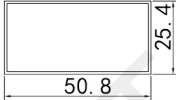
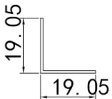
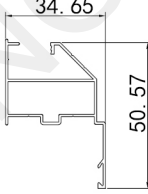
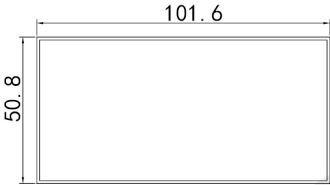
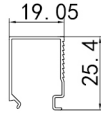
No.	Drawing	Thickness mm	Weight kg/m	No.	Drawing	Thickness mm	Weight kg/m
SD179A		0.9	0.4	SD175A		0.9	0.383
SW696A		0.9	0.391	CW368-A		0.8	0.133
CW367-KSS		0.85	0.289	SW701A		0.9	0.241
SW700A		0.9	0.293	SW699A		0.9	0.306
SW697A		0.9	0.289	CH02		1.1	0.105
P805A		0.75	0.08	CW371-KSS		0.9	0.478

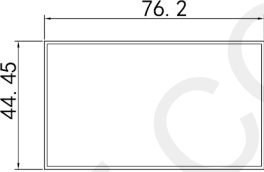
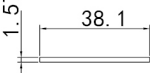
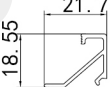
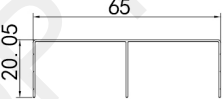
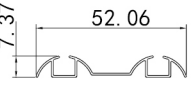
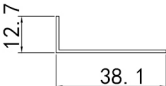

马来西亚

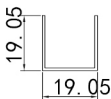
No.	Drawing	Thickness mm	Weight kg/m	No.	Drawing	Thickness mm	Weight kg/m
CW375-KSS		0.9	0.45	EA014		0.8	0.11
P807A		0.75	0.16	CF062-S		0.9	0.194
SW936A		0.9	0.316	SW698A		0.9	0.228
RH048		0.9	0.643	RH137		0.9	0.343
EA086		0.9	0.101	CW1375DC		0.85	0.391
RH163210		1.0	0.821	CW1372		0.8	0.173

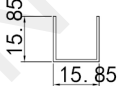
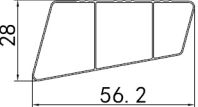
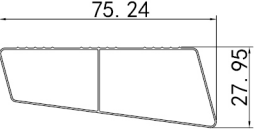
马来西亚

No.	Drawing	Thickness mm	Weight kg/m	No.	Drawing	Thickness mm	Weight kg/m
RH142410		1.0	0.648	FB1216		1.57	0.163
70916A		1.1	0.175	WCN0116		0.65	0.217
WCN0117		0.65	0.17	UA041210		1.0	0.136
EA040409		0.9	0.06	EC060609		0.9	0.136
90315		0.75	0.05	EC050509		0.85	0.106
AA04477		0.9	0.239	AA04478		0.5	0.288

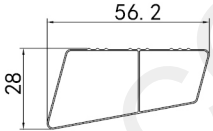
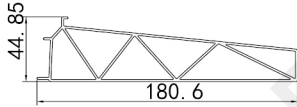
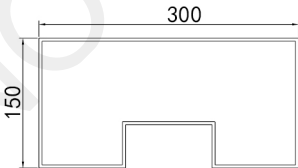
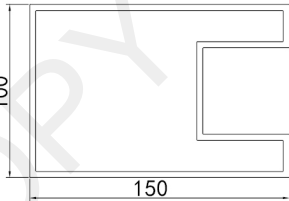
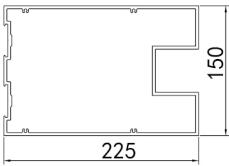
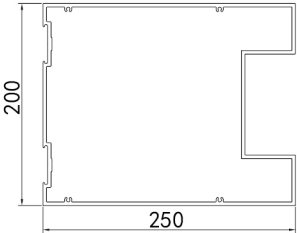
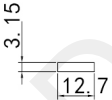
马来西亚

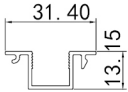
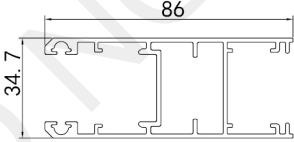
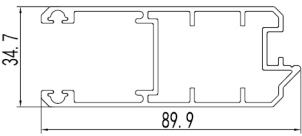
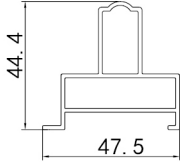
No.	Drawing	Thickness mm	Weight kg/m	No.	Drawing	Thickness mm	Weight kg/m
AA04479		0.45	0.212	AA04476		1.45	2.5
AA04463		3.5	9.42	AA04464		3.5	5.6
AA04465		3.5	8.42	AA04466		3.5	9.86
FB0432		3.15	0.11	EA050509		0.85	0.07
70926		1.15	0.215	70922		1.45	1.27
70895		1.55	1.327	70811		1.35	0.68

马来西亚

No.	Drawing	Thickness mm	Weight kg/m	No.	Drawing	Thickness mm	Weight kg/m
91774		14	10.1	SMC 02-100		1.3	0.782
SMC 02-101		1.3	0.471	SMC 02-102		1.3	0.576
SMC 02-103		1.3	0.647	SMC 02-110		1.3	0.39
SMC 02-111		1.3	0.775	SMC 02-104		1.3	0.52
SMC 02-105		1.3	0.62	SMC 02-106		1.3	0.7
SMC 02-107		1.3	0.97	SMC 02-108		1.3	1.11

马来西亚

No.	Drawing	Thickness mm	Weight kg/m	No.	Drawing	Thickness mm	Weight kg/m
SMC 02-109		1.3	0.76	R97		0.9	0.55
WCN0063		0.7	0.072	70429 S		1.1	0.71
70428 S		1.5	1.77	70097		2.15	0.138
91562		1.35	0.71	91563		1.3	1.02
91564		0.95	0.248	91571		1.25	0.873
91570		1.35	0.908	91569		1.35	1.27



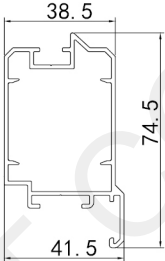
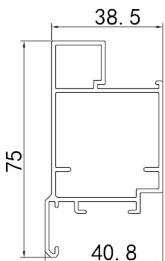
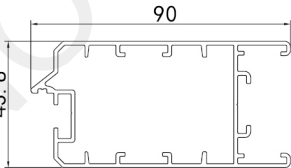
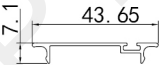
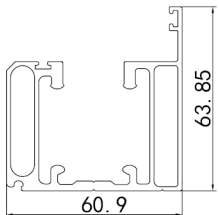
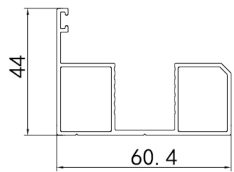
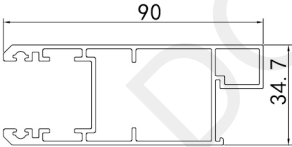
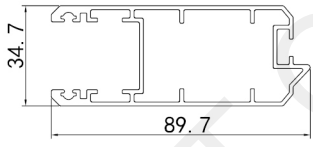
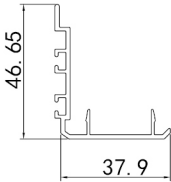
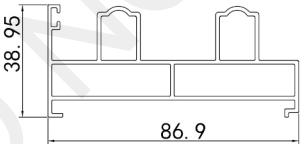
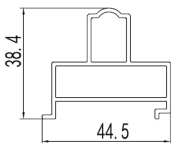
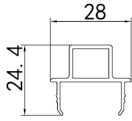

马来西亚

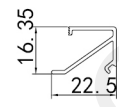
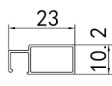
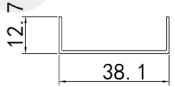
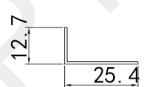
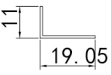
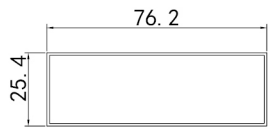
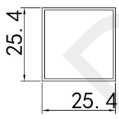
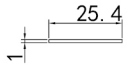
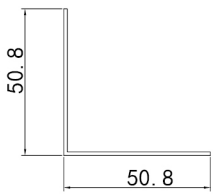
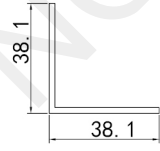
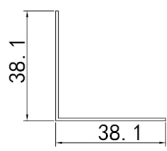
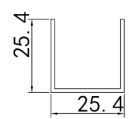
No.	Drawing	Thickness mm	Weight kg/m	No.	Drawing	Thickness mm	Weight kg/m
91560		1.35	0.922	91561		1.35	0.942
91565		1.35	1.26	91566		1.0	0.178
91567		1.45	1.691	91568		1.25	0.752
91572		1.35	1.264	91573		1.35	1.254
91574		1.45	0.455	91575		1.35	1.268
91576		1.35	0.628	70677		1.25	0.28

马来西亚

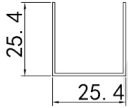
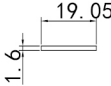
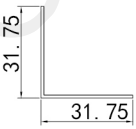
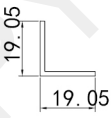
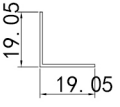
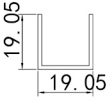
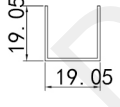
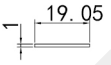
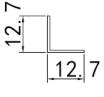
No.	Drawing	Thickness MM	Weight KG/M	No.	Drawing	Thickness MM	Weight KG/M
91577		1.15	0.189	IS4303		0.7	0.123
UC041210		0.9	0.151	UA040808		0.8	0.081
UA030609		0.9	0.072	RH082409		0.9	0.49
SH080808		0.8	0.215	FB0810		1.0	0.069
EA161612		1.2	0.329	EA121220		2.0	0.405
EA121209		0.9	0.185	EC080813		1.3	0.261

马来西亚

No.	Drawing	Thickness mm	Weight kg/m	No.	Drawing	Thickness mm	Weight kg/m
EC080809		0.9	0.183	FB0616		1.6	0.083
EA101010		1.0	0.171	EA060616		1.6	0.159
EA060609		0.9	0.091	EC060613		1.3	0.194
EC060609		0.9	0.136	FB0610		1.0	0.052
EA040408		0.8	0.054	EA030309		0.9	0.045
EC040409		0.9	0.089	EC030309		0.9	0.066

马来西亚

No.	Drawing	Thickness mm	Weight kg/m	No.	Drawing	Thickness mm	Weight kg/m
LV4101		1.0	0.224	LV4100		1.0	0.191
SLD 2191S		1.0	0.255	SLD 2750S		1.0	0.291
SLD2274		1.1	0.477	SLD2279		1.1	0.488
80307		0.8	0.114	85000		1.0	0.351
85001		1.0	0.492	90819		1.7	0.959
90820		1.6	0.968	90835		1.55	1.069



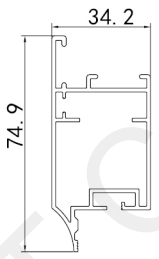
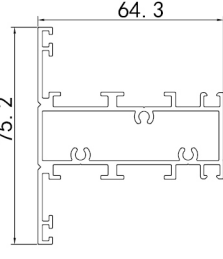
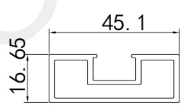
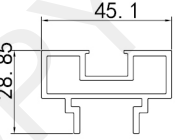
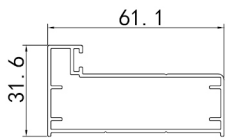
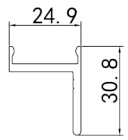
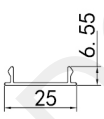
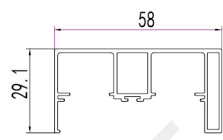
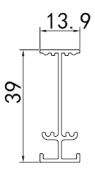
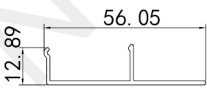
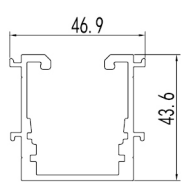
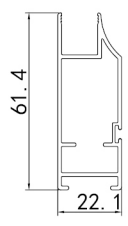

马来西亚

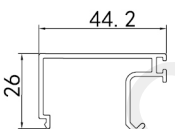
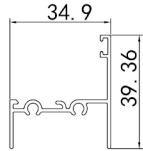
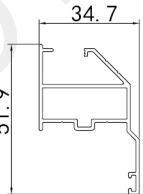
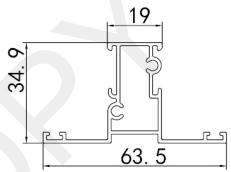
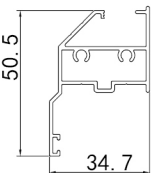
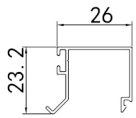
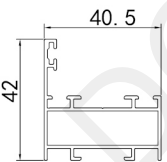
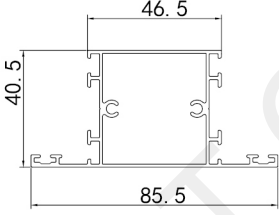
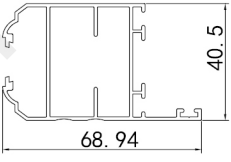
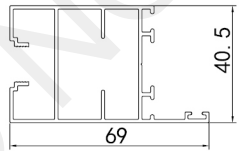
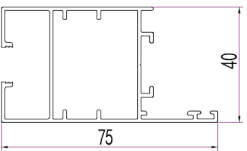
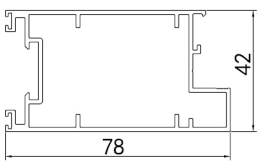
No.	Drawing	Thickness mm	Weight kg/m	No.	Drawing	Thickness mm	Weight kg/m
90837		1.3	0.887	90838		1.55	1.433
90857		1.9	0.643	90858		1.9	0.818
90859		1.1	0.604	90920		0.393	2.75
90921		0.95	0.102	90930		1.15	0.642
90931		1.1	0.271	90932		1.1	0.289
90964		1.95	1.095	90994		1.3	0.649

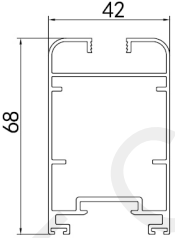
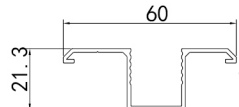
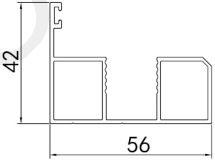
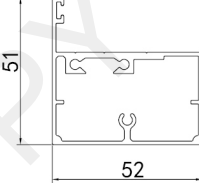
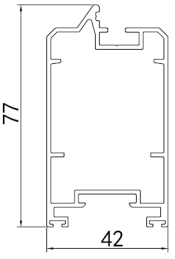
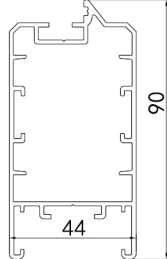

马来西亚

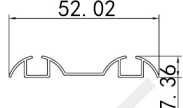
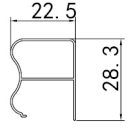
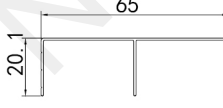
No.	Drawing	Thickness mm	Weight kg/m	No.	Drawing	Thickness mm	Weight kg/m
91231		1.55	0.48	CW1617		1.15	0.361
CW1618		1.15	0.513	CW1382		1.15	0.602
CW1383		1.15	0.566	70091S		0.9	0.213
70092S		1.05	0.546	70095S		1.05	0.889
70096S		1.15	0.855	70898S		1.15	0.881
70932S		1.15	0.875	70592S		1.4	1.142

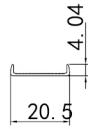
马来西亚

No.	Drawing	Thickness mm	Weight kg/m	No.	Drawing	Thickness mm	Weight kg/m
70427S		1.15	1.023	70594S		1.3	0.385
70595S		1.3	0.708	70597S		1.3	0.96
70600S		1.4	1.146	70782S		1.4	1.347
70990S		0.95	0.114	80260		0.75	0.193
90313		0.65	0.171	80262		0.8	0.266
90315		0.75	0.05	90303		0.9	0.059

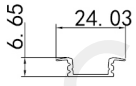
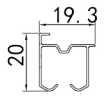
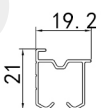
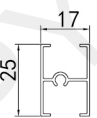
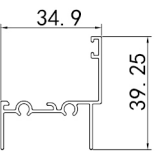
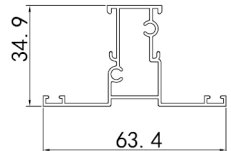
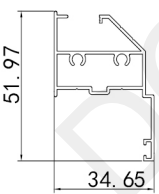
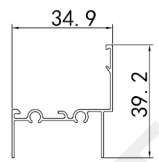
马来西亚

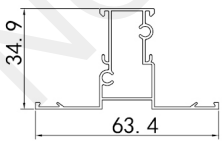
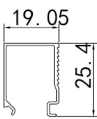
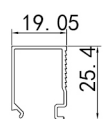
No.	Drawing	Thickness mm	Weight kg/m	No.	Drawing	Thickness mm	Weight kg/m
90933S		0.7	0.09	CR5710S		0.65	0.124
CR5713		0.85	0.163	CW1062		0.9	0.2
CW1263		1.0	0.316	CW1264		1.0	0.515
CW1265		1.0	0.497	CW1367SS KT		0.8	0.254
CW1368		0.75	0.123	CW1371SS KT		0.85	0.435
CW1372		0.8	0.186	CW1384		0.95	0.209



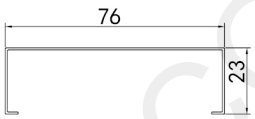
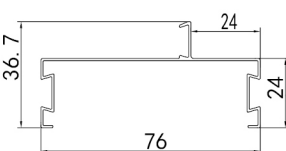
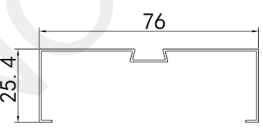
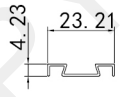
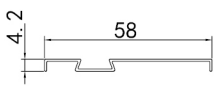
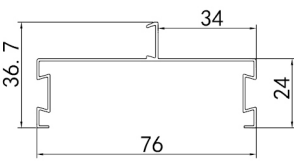
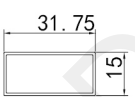
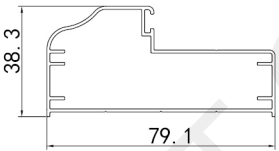
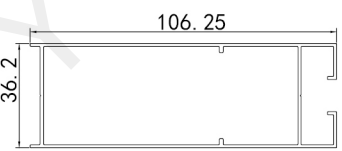
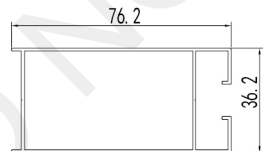

马来西亚

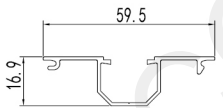
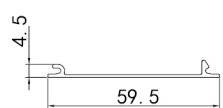
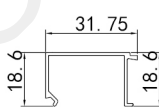
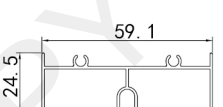
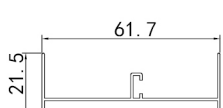
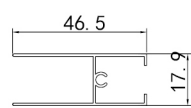
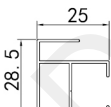
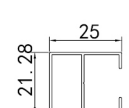
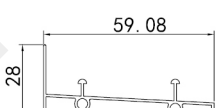
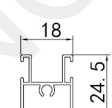
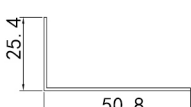
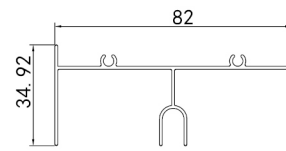
No.	Drawing	Thickness MM	Weight KG/M	No.	Drawing	Thickness MM	Weight KG/M
P3530		0.75	0.262	P3801		0.75	0.359
P3803		0.7	0.273	P3805		0.7	0.074
P3807		0.75	0.153	P3821		0.75	0.359
RH051009		0.85	0.21	SD2343		1.05	0.727
SD2347		1.05	0.917	SD2351		0.95	0.673
		0.8	0.103			0.8	0.165

马来西亚

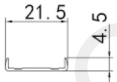
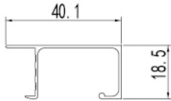
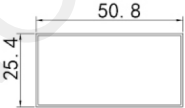
No.	Drawing	Thickness mm	Weight kg/m	No.	Drawing	Thickness mm	Weight kg/m
SF3354S		1.05	0.324	WCN 0100		1.0	0.211
SF 3617S		0.95	0.195	SLW 1696S		0.85	0.368
SLW 1697S		0.85	0.273	SLW 1699S		0.85	0.288
SLW 1700S		0.85	0.277	SLW 1701S		0.85	0.229
SLW 1936S		0.85	0.302	SLW 1698S		0.85	0.215
UA081609		0.9	0.185	SLD2745S		1.0	0.58

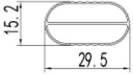
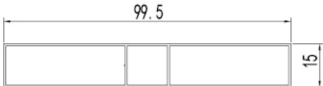
马来西亚

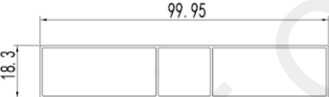
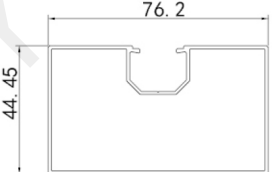
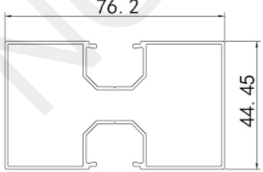
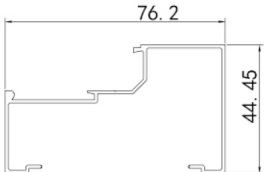
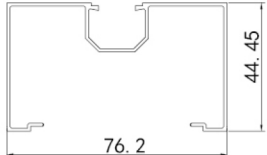
No.	Drawing	Thickness mm	Weight kg/m	No.	Drawing	Thickness mm	Weight kg/m
70976		0.9	0.046	70973S		0.9	0.218
RH081607		0.7	0.286	RH040807		0.7	0.14
90242 S		0.9	0.169	FC001B		0.7	0.485
CN8190		1.0	0.06	FC003		0.75	0.547
SF3183S		1.05	0.786	SF3184S		1.05	0.892
SF3352S		1.05	0.584	SF3353S		1.05	0.652

美国

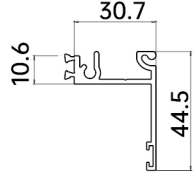
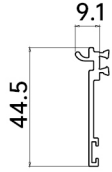
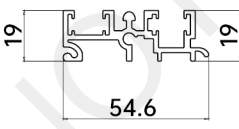
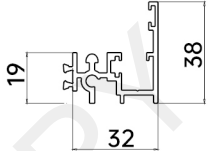
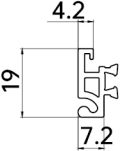
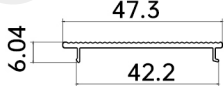
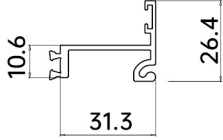
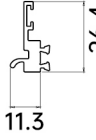
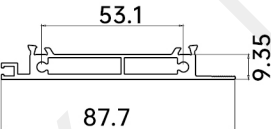
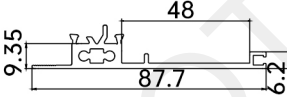
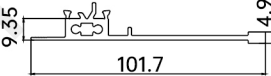
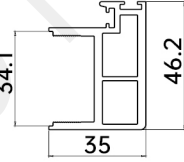
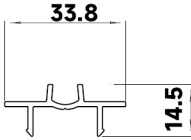
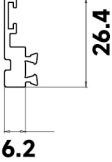
No.	Drawing	Thickness /mm	Weight kg/m	No.	Drawing	Thickness /mm	Weight kg/m
MGZ-001		1.8	0.59	MGZ-002		1.8	0.333
MGZ-005		1.8	0.817	MGZ-003		1.8	0.663
MGZ-004		1.8	0.253	MGZ-015		1.7	0.218
MGZ-006		1.6	0.414	MGZ-007		00	0.32
MGZ-008		2.0	0.922	MGZ-009		2.0	0.803
MGZ-010		2.0	0.914	MGZ-012		00	1.19
MGZ-013		00	0.23	MGZ-014		00	0.298

美国

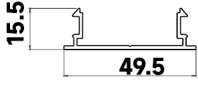
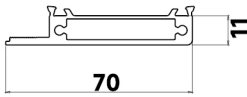
No.	Drawing	Thickness /mm	Weight kg/m	No.	Drawing	Thickness /mm	Weight kg/m
MGZ-016		1.5	0.332	MGZ-011		00	0.862
MGZ-005				MGZ-003			

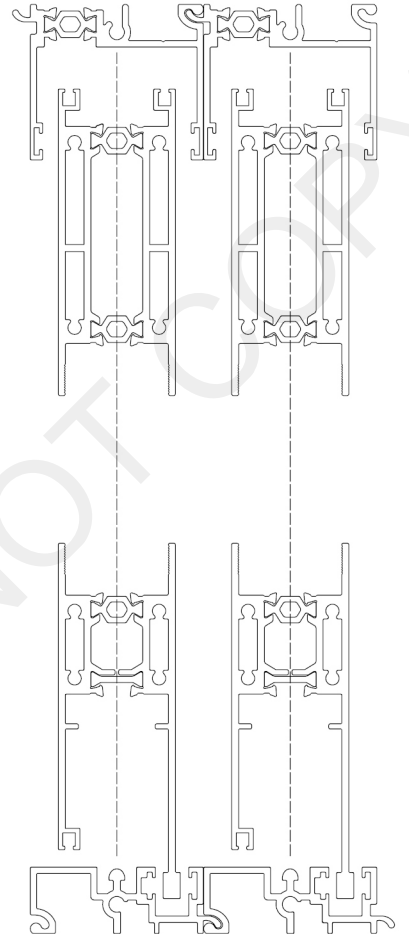
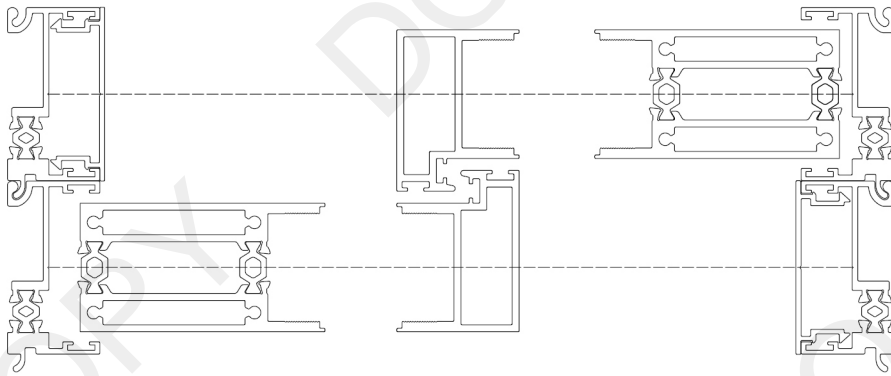

马拉维

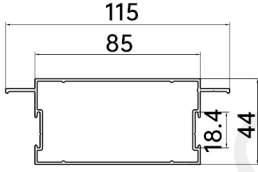
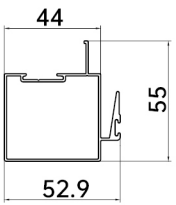
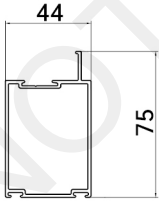
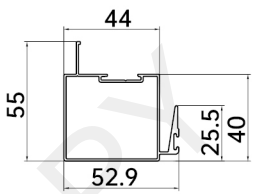
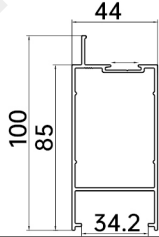
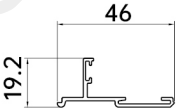
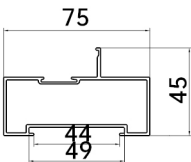
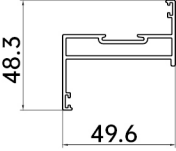
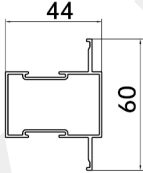
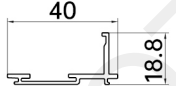
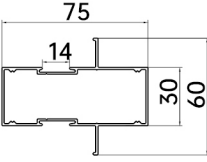
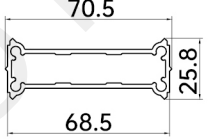
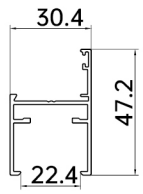
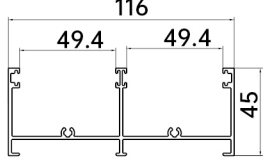
No.	Drawing	Thickness /mm	Weight kg/m	No.	Drawing	Thickness /mm	Weight kg/m
SFSF022		1.18	1.024	SFPD224		1.0	0.69
SFSF019		1.6	1.038	SFPD223		1.0	0.69
SFSF004		1.6	1.216	SFSF114		1.3	0.287
SFSF001		1.4	0.94	SFSF100		1.5	0.735
SFSF005		1.1	0.632	SFSF050		1.7	0.27
SFSF002		1.4	0.99	SFCM066		2.2	0.99
SFCM030		1.3	0.464	SFPD201		1.6	1.332



马拉维

No.	Drawing	Thickness /mm	Weight kg/m	No.	Drawing	Thickness /mm	Weight kg/m
SFSF022		1.18	1.024	SFPD222		1.0	0.95
SFCM032B		1.1	0.45	SFPD002A		1.5	1.25
SFCM034		1.0	0.159	SFPD002		1.6	1.116
SFSF006		1.05	0.122	SFSF107		1.4	0.478
SFPD702		1.3	0.731	SFPD701		1.3	0.852
SFPD703		1.3	0.672	SFFD001B		1.4	1.155
SFPD722		1.2	0.749	SFSF064		4.4	0.732

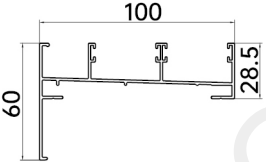
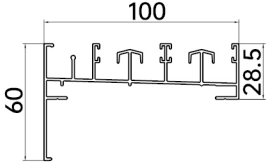
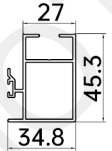
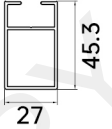
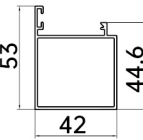
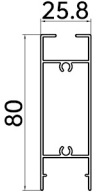
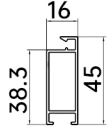
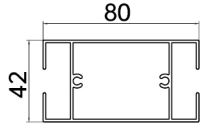
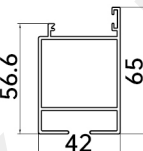
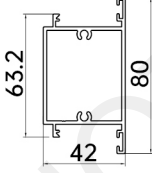
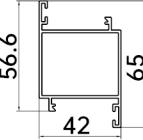
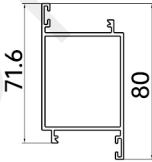
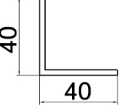

马拉维

No.	Drawing	Thickness /mm	Weight kg/m	No.	Drawing	Thickness /mm	Weight kg/m
SFPD704		1.2	0.62	I156		1.2	0.208
SFPD725		1.2	0.254	SFSF062A		1.85	0.414
SFPD707		1.3	0.55	SFFD015		2.5	0.283
SFSPD705		1.4	0.588	SFSF032A		1.2	0.515
SFSF035		1.2	0.515	SFSF035		1.2	0.515
SFSF002				SFCM066			
SFCM030				SFPD201			

布隆迪

No.	Drawing	Thickness /mm	Weight kg/m	No.	Drawing	Thickness /mm	Weight kg/m
BLD-01		1.3	0.986	BLD-02		1.24	1.237
BLD-03		1.4	0.699	BLD-04		1.4	0.582
BLD-05		1.35	0.69	BLD-06		1.22	0.807
BLD-07		1.22	0.414	BLD-08		1.36	1.175
BLD-09		1.56	1.000	BLD-10		1.79	1.21
BLD-11		1.35	0.796	BLD-12		1.67	1.061
BLD-13		2.8	0.59	BLD-14		1.1	0.22

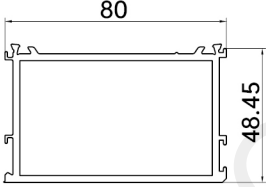
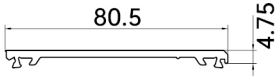
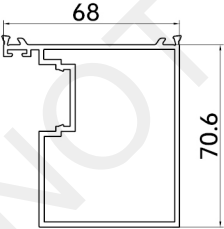
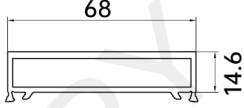
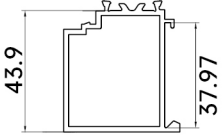
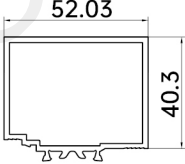
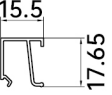
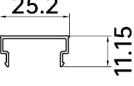
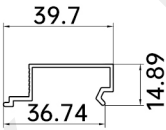
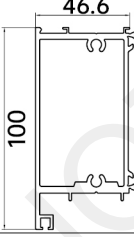

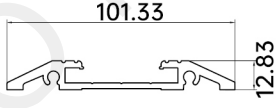
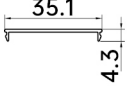
断桥地弹簧门系列

No.	Drawing	Thickness /mm	Weight kg/m	No.	Drawing	Thickness /mm	Weight kg/m
KN-042		2.5	1.768	KN-043		2.5	0.643
KN-044		2.0	1.566	KN-045		2.4	0.951
KN-046		2.0	0.906	KN-047		2.0	1.018
KN-048		1.0	0.151	KN-049		1.0	0.121
KN-050		1.19	0.247	KN-051		3.0	2.098
KN-052		2.0	0.629	KN-053		2.5	1.29
KN-054		1.0	0.109	KN-55		1.1	0.22

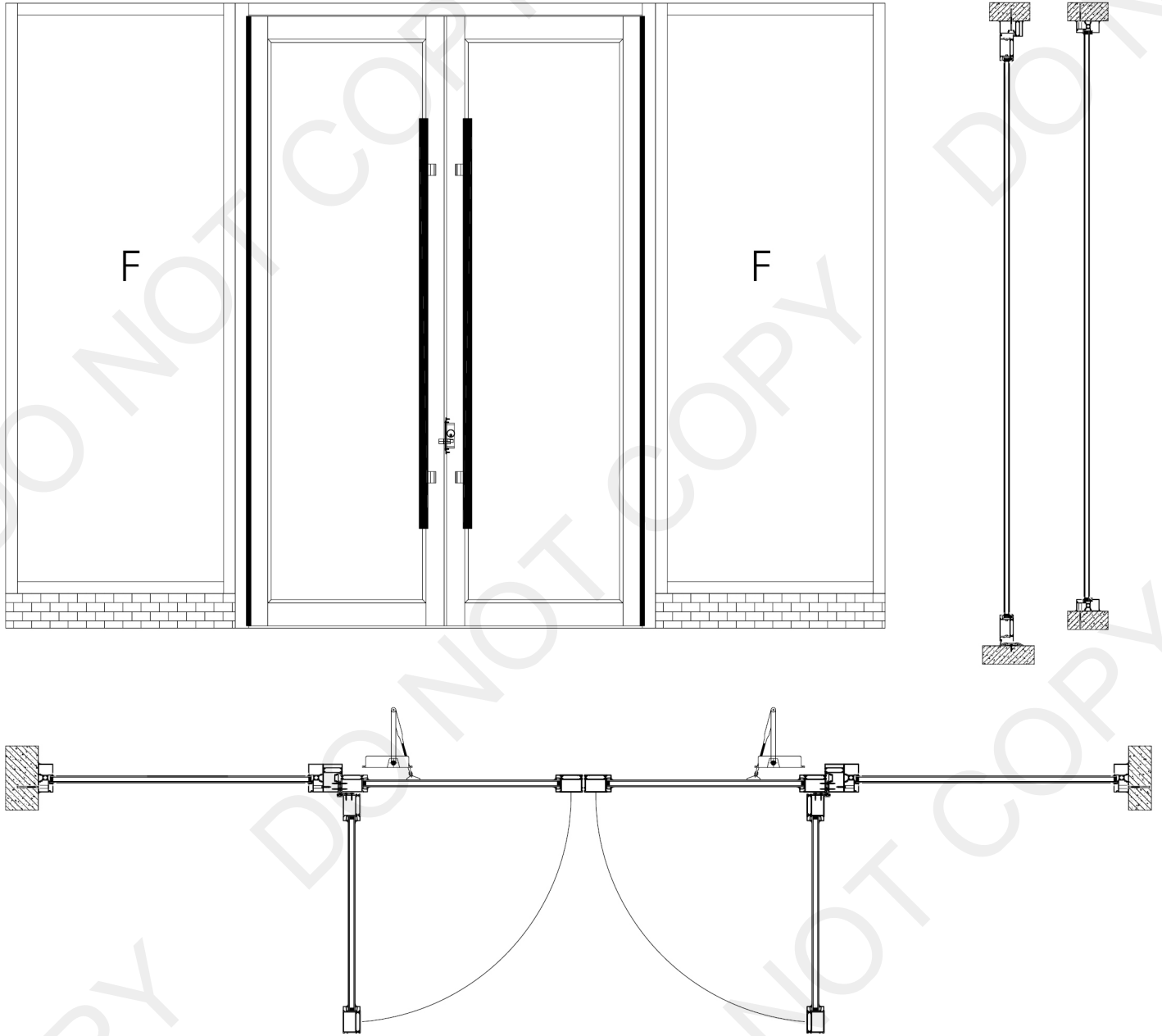
断桥地弹簧门系列

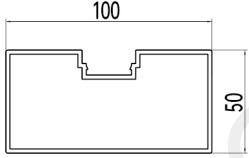
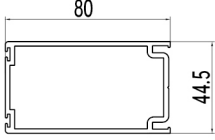
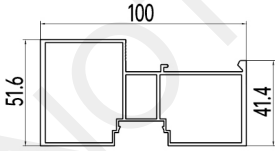
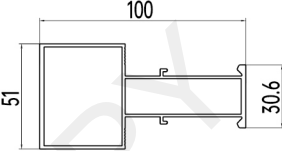
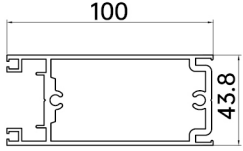
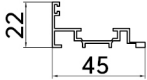
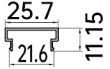
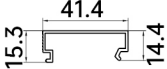
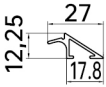
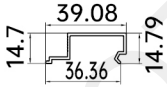
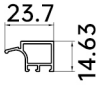

办公隔断系列

No.	Drawing	Thickness /mm	Weight kg/m	No.	Drawing	Thickness /mm	Weight kg/m
KN-055		2.0	1.729	KN-056		2.2	0.792
KN-057		2.4	1.69	KN-058		2.2	1.47
KN-059		2.0	2.171	KN-060		1.2	0.33
KN-061		1.0	0.133	KN-062		1.2	0.263
KN-063		1.2	0.17	KN-064		1.3	0.235
KN-065		1.2	0.208	KN-066		1.2	0.173
KN-13		2.8	0.59	KN-14		1.1	0.22

办公隔断系列

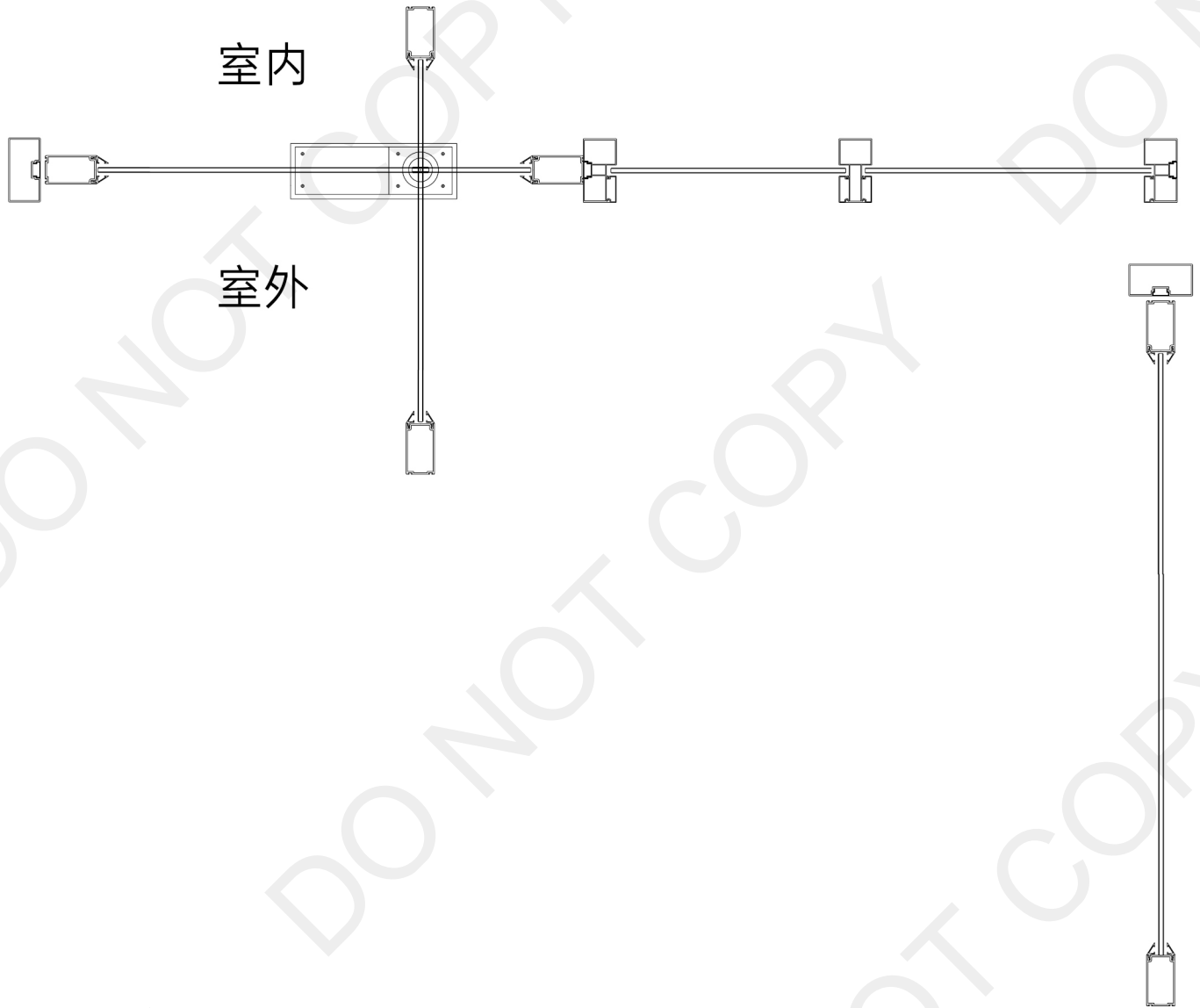

艺术门系列

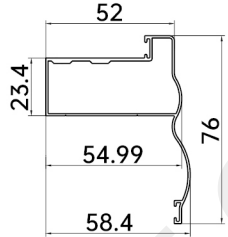
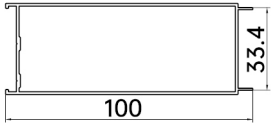
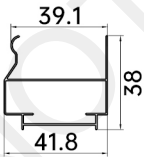
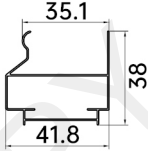
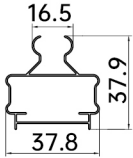
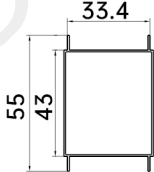
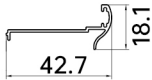
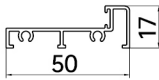
No.	Drawing	Thickness /mm	Weight kg/m	No.	Drawing	Thickness /mm	Weight kg/m
YSM-01		1.2	0.63	YSM-02		1.2	0.82
YSM-03		0.6	0.275	YSM-04		0.6	0.28
YSM-05		0.6	0.27	YSM-06		0.7	0.35
YSM-07		1.0	0.19	YSM-08		1.2	0.378
YSM-09		1.56	1.000	YSM-10		1.79	1.21
YSM-11		1.35	0.796	YSM-12		1.67	1.061
YSM-13		2.8	0.59	YSM-14		1.1	0.22